



Three/Five Axes Servo Driven Robot (Driven-control integrated)

ST5-800-1400DT-S2-I



Refer carefully to this manual before operation.

ST3/5 Series

■ Coding Principle

ST3/5 - xxx - xxx DT - S - I

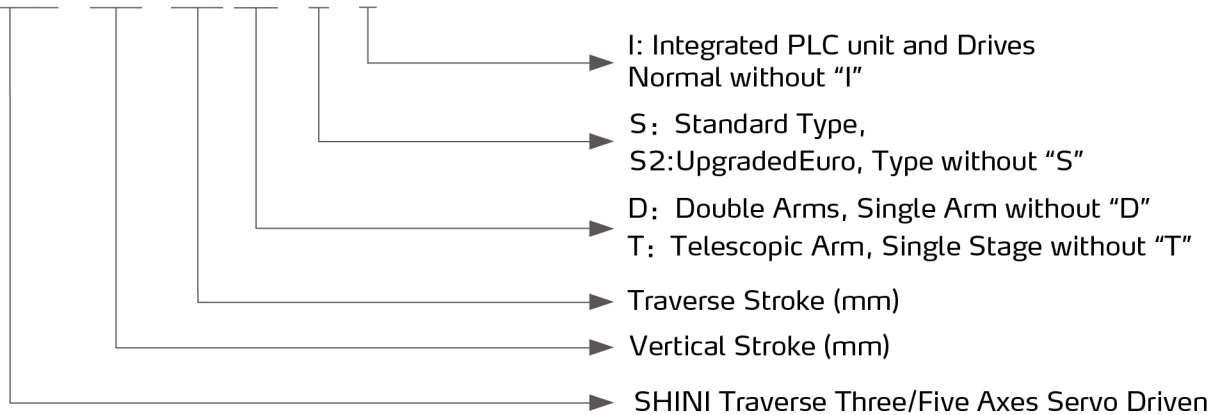

■ Features

- Advanced driver ensures stable performance;
- Highly modular design and card split structure makes it only has to change corresponding module without disassembling and replacing the whole machine during maintenance, which is better than most of other drive-control units in the market.
- The shared DC bus makes the driver work more stably, with better overload capacity. Moreover, it only needs a regenerative resistor, which saves mount space.
- The main control module and the servo module are connected in the unified base plate, which avoid cumbersome manual wiring and increases the system's stability and reliability;
- The servo parameters can be set by the control plate automatically;
- The bus controlled interface is suitable for all kinds of IMM's (national, European and Japanese standards), suitable for new 8" manipulator;
- It not only features the split stability, but also saves the labor works of wiring, and it shortens the size of the control box.

■ Application

Thina series robot is designed for rapid and precise removal of products from injection molding machine, and place them at desired locations. Apply to 2/3-plate mold or hot runner system. Capable of arranging, stacking, quality checking and in mold placement. Suitable for injection molding machine with clamping force 80~300 tons.

Outline Drawings

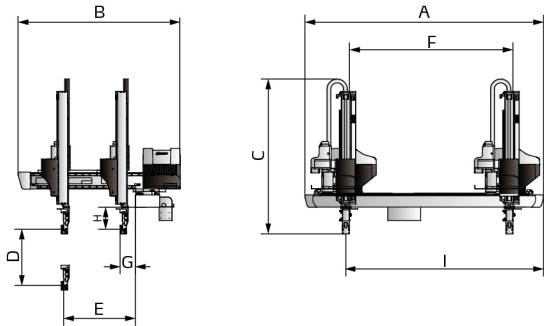

3-axis servo with single kick-stroke beam

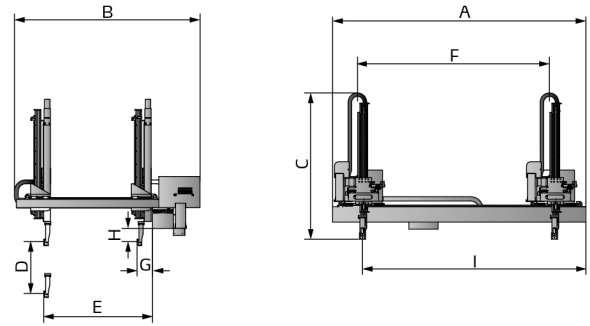

3-axis telescopic arm with frame type beam

Specifications

Model	ST3-	800-1400T-S2-I	1000-1600T-S2-I	1200-1800T-S2-I	1300-2000T-S2-I
Robot Type		Single kick stroke beam	Single kick stroke beam	Frame type beam (Drive-control Integrated)	Frame type beam (Drive-control Integrated)
IMM (ton)		80-160	180-300	320-450	480-650
Traverse Stroke (mm)		1400	1600	1800	2000
Crosswise Stroke (mm)	Main Arm	800	900	1100	1100
	Sub. Arm	-	-	-	-
Vertical Stroke (mm)	Main Arm	800	1000	1200	1300
	Sub. Arm	-	-	-	-
Max Load (with tool) (kg)		5	5	6	6
Min Pick-out Time (sec)		1.3	1.4	1.5	1.8
Min Cycle Time (sec)		5.2	5.5	6.5	6.8
Air Pressure (bar)		4~6	4~6	4~6	4~6
Max. Air Consumption (NL/cycle)*		4	4	4	6
Weight (kg)		250	300	320	340
Dimensions (mm)	A	2100	2310	2550	2750
	B	1600	1800	1950	1900
	C	1300	1400	1550	1500
	D	800	1000	1200	1300
	E	800	900	1160	1160
	F	1400	1600	1800	2000
	G	180	180	250	250
	H	230	230	200	200
	I	1650	1900	2200	2400

Notes: 1) "M" stands for middle mold detector. (suitable for three-plate mold.)

"EM12" stands for EUROMAP 12 communication interface.

"EM67" stands for EUROMAP 12 communication interface.

"N" stands for non-operation side, operation side without "N"

2) Power supply: 1Φ, 200~240V, 50/60Hz.

3) * * * Max. air consumption for vacuum device 60NL/min.

ST3/5 Series

Outline Drawings

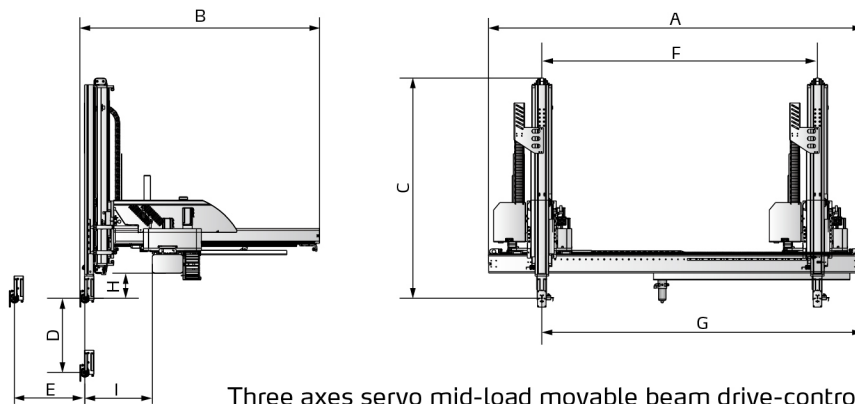

Three axes servo mid-load movable beam drive-control integrated robot

Specifications

Model	ST3-	1400-2000MT-S-I	1600-2200MT-S-I	1800-2400MT-S-I
Robot Type	Movable beam type (Drive-control Integrated)			
IMM (ton)		480-650	650-850	850-1400
Traverse Stroke (mm)		2000	2200	2400
Crosswise Stroke (mm)	Main Arm	1000	1600	1600
	Sub. Arm	-	-	-
Vertical Stroke (mm)	Main Arm	1400	1600	1800
	Sub. Arm	-	-	-
Max Load (with tool) (kg)		10	20	20
Min Pick-out Time (sec)		3	3.3	3.6
Min Cycle Time (sec)		13	14	16
Air Pressure (bar)		4~6	4~6	4~6
Max. Air Consumption (NI/cycle)*		6	6	6
Weight (kg)		530	580	650
Dimensions (mm)	A	2700	2900	3100
	B	1817	2500	2500
	C	1680	1890	1990
	D	1400	1600	1800
	E	1000	1600	1600
	F	2000	2200	2400
	G	2450	2650	2850
	H	145	220	220
	I	355	355	355

Notes: 1) "M" stands for middle mold detector. (suitable for three-plate mold.)

"EM12" stands for EUROMAP 12 communication interface.

"EM67" stands for EUROMAP 12 communication interface.

"N" stands for non-operation side, operation side without "N"

2) Power supply: 1Φ, 200-240V, 50/60Hz.

3) " * " Max. air consumption for vacuum device 60NI/min.

Outline Drawings

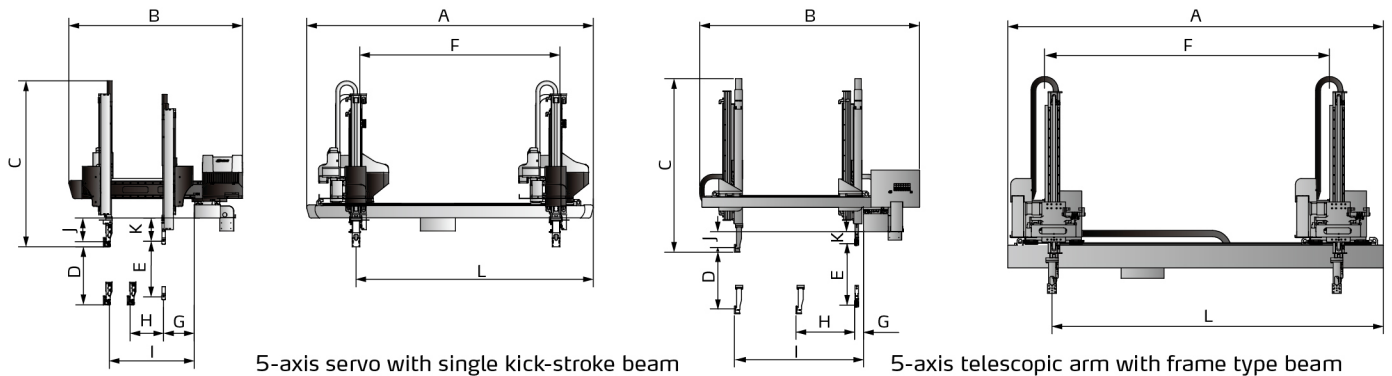

Specifications

Model	ST5-	800-1400DT-S2-I	1000-1600DT-S2-I	1200-1800DT-S2-I	1300-2000DT-S-I	1500-2200DT-S-I
Robot Type	5-axis servo with single kick-stroke beam			5-axis telescopic arm with frame type beam		
IMM (ton)		80-160	180-300	320-450	480-650	660-850
IMM (ton)		1400	1600	1800	2000	2200
Crosswise Stroke (mm)	Main Arm	500	700	850	850	1050
	Sub. Arm	500	700	850	850	1050
Vertical Stroke (mm)	Main Arm	800	1000	1200	1300	1500
	Sub. Arm	800	1000	1200	1300	1500
Max Load (with tool) (kg)		5	5	6	6	12
Min Pick-out Time (sec)		1.3	1.4	1.5	1.8	2.0
Min Cycle Time (sec)		5.2	5.5	6.3	6.8	12
Air Pressure (bar)		4-6	4-6	4-6	4-6	4-6
Max. Air Consumption (NI/cycle) *		4	4	4	6	6
Weight (kg)		290	320	340	360	450
Dimensions (mm)	A	2060	2310	2550	2750	3100
	B	1600	1700	1900	1900	2160
	C	1250	1350	1450	1500	1740
	D	800	1000	1200	1300	1500
	E	800	1000	1200	1300	1500
	F	1400	1600	1800	2000	2200
	G	180	180	250	250	230
	H	110	110	220	220	440
	I	800	900	1160	1160	1540
	J	230	230	200	200	245
	K	220	220	200	200	245
	L	1650	1900	2200	2400	2620

Notes: 1) "M" stands for middle mold detector. (suitable for three-plate mold.)

"EM12" stands for EUROMAP 12 communication interface.

"EM67" stands for EUROMAP 12 communication interface.

"N" stands for non-operation side, operation side without "N"

2) Power supply: 1Φ, 200-240V, 50/60Hz.

3) " * " Max. air consumption for vacuum device 60NI/min.

Shini Group

Addr: No. 23, Minhe St., Shulin Dist.,
New Taipei, Taiwan

Tel: +886 2 2680 9119

Fax: +886 2 2680 9229

Email: shini@shini.com

Factories:

- Taiwan
- Dongguan
- Pinghu
- Ningbo
- Chongqing
- Pune

2024-06-15-04 Copyrights Reserved.

www.shini.com