

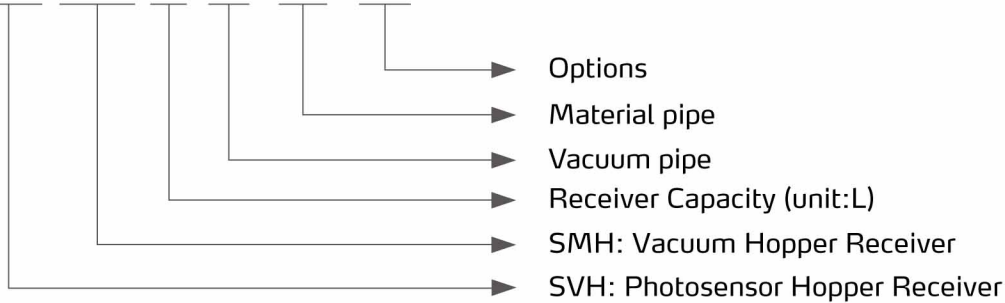

## SVH/SMH Series

### ■ Coding Principle

SVH/SMH-xL -xA - xM - xxx



### ■ Features

- This series of hopper receiver can work with most of the main vacuum units, such as SAL-G and SAL-UG series.
- SMH receiver is suitable for mounting on the dryer, storage tank, or machine hopper.
- SVH receiver is designed to be mounted directly on feeding throat of the plastic processing machine. It required no machine hopper and kept very little dried material before the process.
- Stainless steel hopper receiver.
- Standard equipped with steel wired mesh filter screen.

### ■ Options

- Optional enhanced mixing technology for proportional valve SPV-U application. Add "QM" at the end of the model code.

# SVH/SMH Series

## Outline Drawings

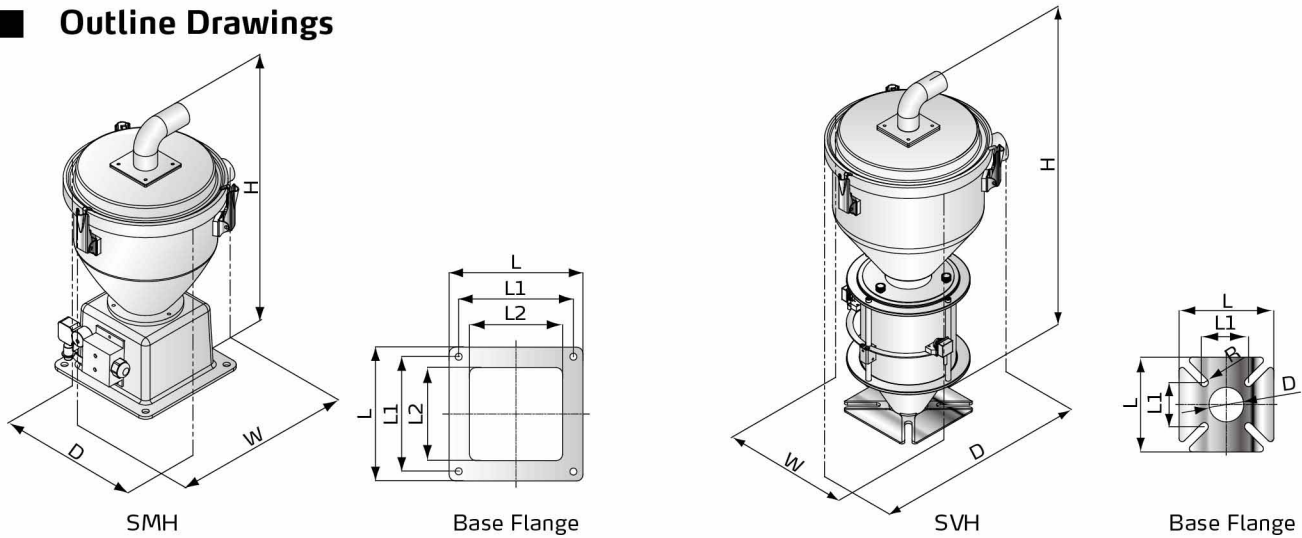

### SVH Specifications

Model	Capacity (L)	Receiver		Conveying pipe dia. (inch)	Vacuum pipe dia. (inch)
		Dimension H×W×D (mm)	Weight (kg)		
SVH-3L	3	460×260×315	3	1.5	1.5
SVH-6L	6	600×260×305	7	1.5	1.5
SVH-12L	12	700×300×365	11	1.5	1.5
SVH-24L	24	1120×360×375	13	2	2

### SVH Base mounting dimensions

Model	L(mm)	L1(mm)	D(mm)	R(mm)
SVH-3L	120	50	40	6.5
SVH-6L	150	70	55	6.5
SVH-12L	180	80	55	6.5
SVH-24L	180	80	80	6.5

### SMH Specifications

Model	Capacity (L)	Receiver		Conveying pipe dia. (inch)	Vacuum pipe dia. (inch)
		Dimension H×W×D (mm)	Weight (kg)		
SMH-6L	6	460 × 260 × 315	7	1.5	1.5
SMH-12L	12	515 × 325 × 350	7	1.5	1.5
SMH-24L	24	720 × 325 × 375	9	2	2

### SMH Base mounting dimensions

	L (mm)	L1 (mm)	L2 (mm)
SMH-6L	210	180	146
SMH-12L			
SMH-24L			



SHR-U

# SHR-U Series

## ■ Coding Principle

SHR - xU - xA- xM - xxx

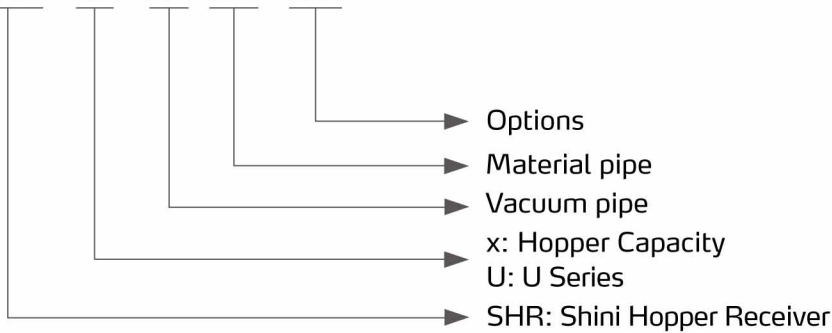

## ■ Features

- This series of hopper receiver can work with the most of main vacuum units and Shini compact dryer SCD, SAL-UG series required 4 pins receiver, and SCD series required 4 pins receiver.
- SHR-U receiver is suitable for mounting on the dryer, storage tank, or machine hopper.
- Stainless steel hopper receiver.
- Standard equipped with steel wired mesh filter screen.

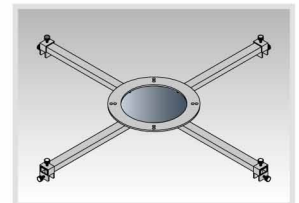

Multifunctional installation frame HMB

## ■ Options

- Multi-functional installation frame HMB suitable for other mounting application with max. 900mm adjustable diameter. Add "HMB" at the end of the model code.
- Optional enhanced mixing technology for proportional valve SPV-U application. Add "QM" at the end of the model code.
- Anti-bridge option at the material outlet for SHR-48U. Applicable for flowing material but bridging from time to time only. Add "MB" at the end of the model code.

# SHR-U-(E) Series

## Outline Drawings

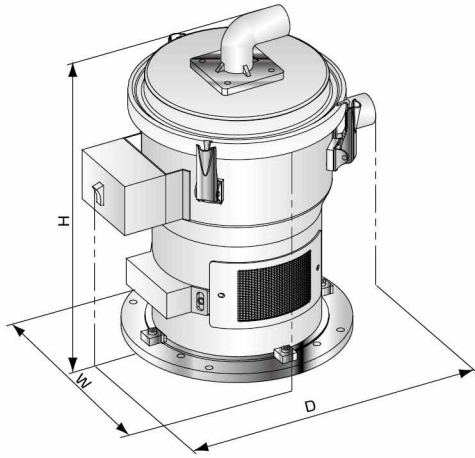

SHR-U

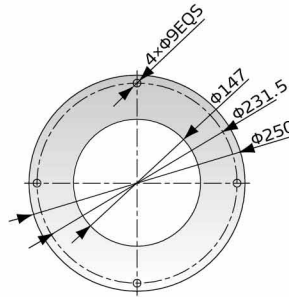

SHR-3U  
Base Flange

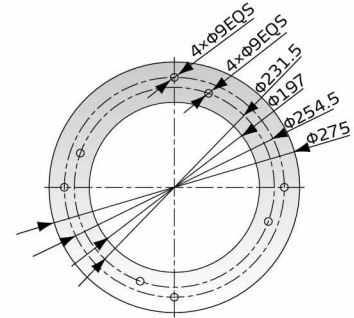

SHR-6U~24U  
Base Flange

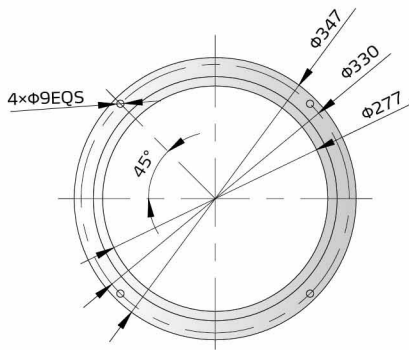

SHR-36U~96U  
Base Flange

## Specifications

Model	Receiver			Conveying Pipe Dia. (inch)	Vacuum Pipe Dia. (inch)
	Capacity (L)	Dimension(H×W×D) (mm)	Weight (kg)		
SHR-3U	3	380 × 250 × 330	4	1.5	1.5
SHR-6U	6	420 × 285 × 360	6	1.5	1.5
SHR-12U	12	470 × 315 × 400	7	1.5	1.5
SHR-24U	24	690 × 315 × 400	9	2	2
SHR-36U	36	822 × 348 × 457	11	2	2.5
SHR-48U	48	976 × 348 × 455	15	2.5	3
SHR-96U	96	1095 × 428 × 562	20	2.5	3



SHR-U-S

# SHR-U-S(ES)-(T) Series

## ■ Coding Principle

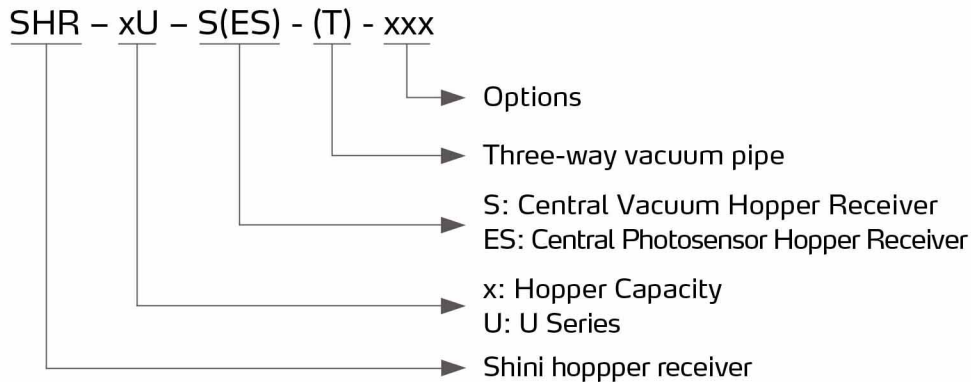

SHR-U-ES

## ■ Features

- This series of centralized hopper receiver can work with the most of central vacuum units such as SAL-UG 122/124 and central conveying system.
- SHR-U-S receiver is suitable for mounting on the dryer, storage tank, or machine hopper.
- SHR-U-E receiver is designed to be mounted directly on feeding throat of the plastic processing machine. It required no machine hopper and kept very little dried material before the process.
- SHR-U-S-T or SHR-U-ES-T can work with multi-component batch blending or injection application. The three-way vacuum pipe allows easy connection of vacuum pipe from receiver to receiver in short proximity application.
- Stainless steel hopper receiver.
- The vacuum valve is used to ensure a good vacuum line without compromising the most demanding conveying capacity.
- Standard equipped with steel wired mesh filter screen.



SHR-U-ST

# SHR-U-S/ES-(T) Series

## Options

- Multiple-functional installation frame HMB suitable for other mounting application with max. 900mm adjustable diameter.
- The optional material one-way flap on each receiver to ensure good vacuum in the common material line conveying system. Add "RSV" at the end of the model code.
- The material discharge flap with extra thickness. Add "SD" at the end of the model code.
- Anti-bridge option at the material outlet for SHR-48U. Applicable for flowing material but bridging from time to time only. Add "MB" at the end of the model code.
- The optional pneumatic check valve is available for SHR-12U/24U/36U-S to avoid suck-back when the material pipe is shared by several hoppers, and add "PSV" at the end of the model code.

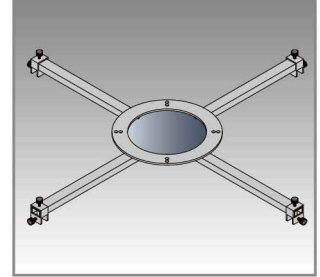

Multifunctional installation frame

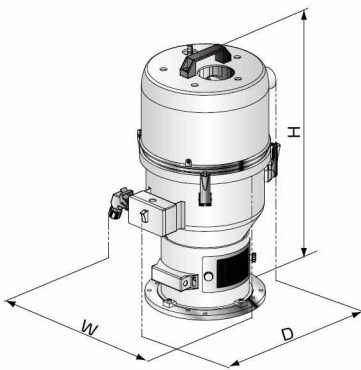

SHR-U-S

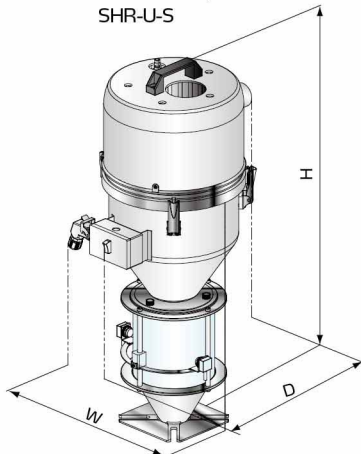

SHR-U-ES

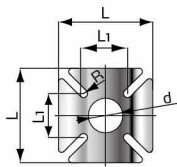

SHR-U-ES Base Flange

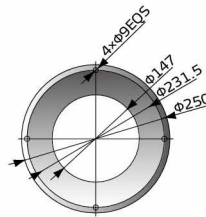

SHR-3U-S Base Flange

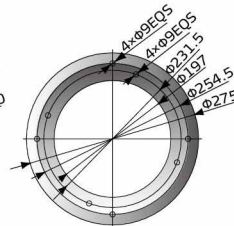

SHR-6U-S-SHR-24U-S Base Flange

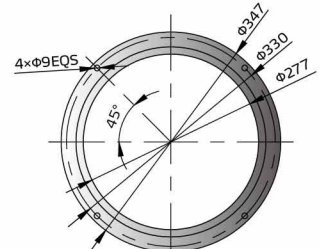

SHR-36U-S-SHR-96U-S Base Flange

## SHR-U-S Specifications

Model	Capacity (L)	Receiver		Conveying Pipe Dia. (inch)	Vacuum Pipe Dia. (inch)
		Dimension (H×W×D)(mm)	Weight (kg)		
SHR-3U-S	3	600 × 270 × 340	4.5	1.5	2
SHR-3U-ES		745 × 270 × 330			
SHR-6U-S	6	560 × 305 × 375	7.5	1.5	2
SHR-6U-ES		730 × 305 × 375			
SHR-12U-S	12	615 × 335 × 405	9	1.5	2
SHR-12U-ES		810 × 335 × 405			
SHR-24U-S	24	825 × 335 × 405	11	2	2.5
SHR-24U-ES		1255 × 400 × 405			
SHR-36U-S	36	1094 × 394 × 469	12	2	2.5
SHR-48U-S	48	1242 × 394 × 456	18	2.5	3
SHR-96U-S	96	1474 × 475 × 556	23	2.5	3

## SHR-U-S Base mounting dimensions

Model	L (mm)	L1 (mm)	d (mm)	R (mm)
SHR-3U-ES	120	50	40	6.5
SHR-6U-ES	150	70	55	6.5
SHR-12U-ES	180	80	55	6.5
SHR-24U-ES	180	85	80	6.5

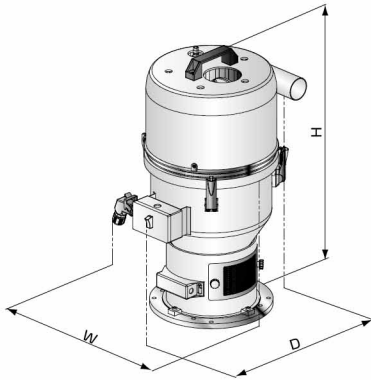

SHR-U-ST

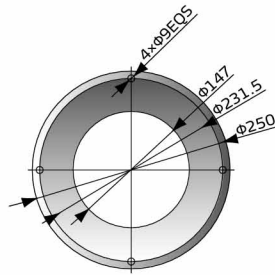

SHR-3U-ST  
Base Flange

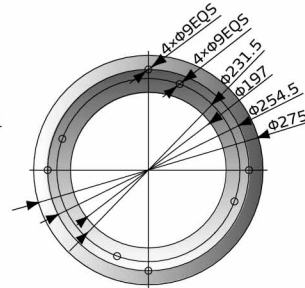

SHR-6U-S-SHR-24U-ST  
Base Flange

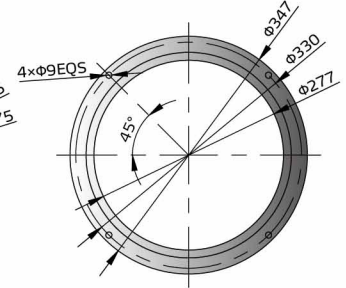

SHR-36U-ST-SHR-48U-ST  
Base Flange

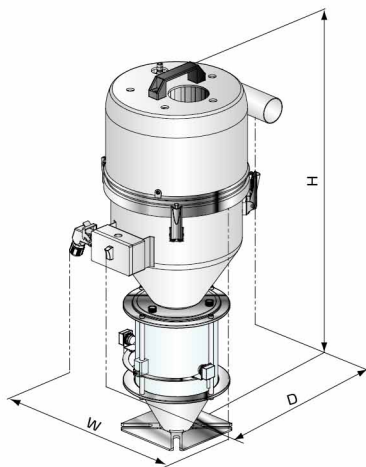

SHR-U-EST

**SHR-U-ST Specifications**

Model	Hopper capacity (L)	Receiver		Conveying Pipe Dia. (inch)	Air Suction Pipe Dia. (inch)
		Dimension (H×W×D) (mm)	Weight (kg)		
SHR-3U-ST	3	600 × 260 × 370	4.5	1.5	2
SHR-3U-EST		745 × 235 × 370			
SHR-6U-ST	6	560 × 290 × 400	7.5	1.5	2
SHR-6U-EST		727 × 280 × 400			
SHR-12U-ST	12	615 × 305 × 440	9	1.5	2
SHR-12U-EST		810 × 305 × 440			
SHR-24U-ST	24	825 × 305 × 455	11	2	2.5
SHR-24U-EST		1255 × 400 × 455			
SHR-36U-ST	36	1094 × 349 × 510	12	2	2.5
SHR-48U-ST	48	1242 × 349 × 504	18	2.5	3

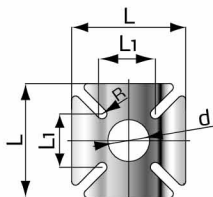

SHR-U-EST  
Base Flange

**SHR-U-EST Base mounting dimensions**

Model	L (mm)	L1 (mm)	d (mm)	R (mm)
SHR-3U-EST	120	50	40	6.5
SHR-6U-EST	150	70	55	6.5
SHR-12U-EST	180	80	55	6.5
SHR-24U-EST	180	85	80	6.5



# SLHR-U-S Series

## ■ Coding Principle

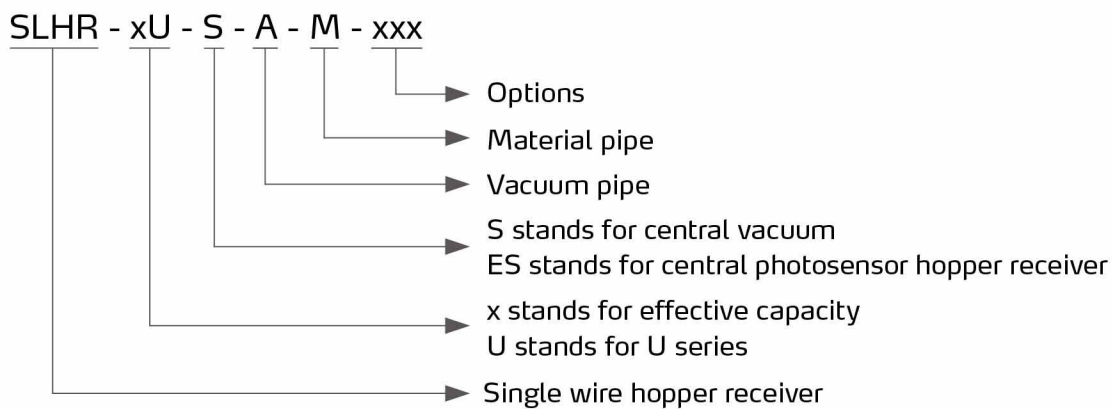

## ■ Features

- This product is mainly used for single wire central conveying system.
- SLHR-3U/6U/12U material pipe and vacuum pipe with a selection of 1.5" or 2" pipe.
- SLHR-U-24U material pipe and vacuum pipe with a selection of 2" or 2.5" pipe.
- The glass pipe is installed at the bottom of SLHR-U-E for temporary storage to ensure no material shortage during the conveying to realize continuous production.
- Stainless steel hopper ensures no material contamination.
- Equipped with vacuum separating valve that can effectively open/close the vacuum loop.
- Standard equipped with steel mesh filter.



## Outline Drawings

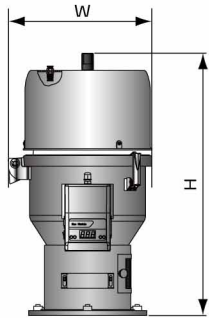

SLHR-U-S

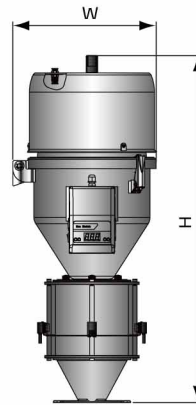
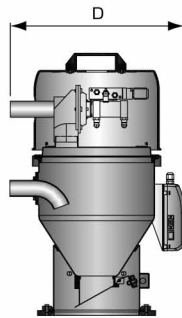

SLHR-U-ES

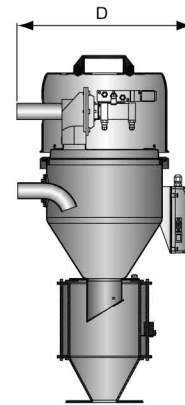

## Specifications

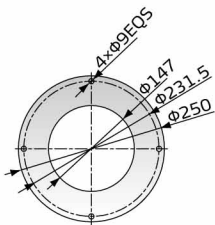

SLHR-3U-S mounting base

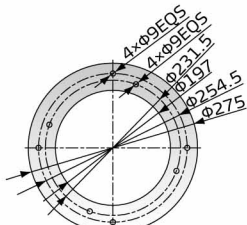

SLHR-6U-24U-S mounting base

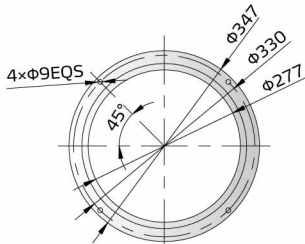

SLHR-36U-96U-S mounting base

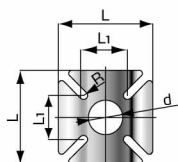

SLHR-U-ES mounting base

Model	Capacity (L)	Dimension (H×W×D) (mm)	Weight (kg)	Conveying Pipe Dia. (inch)	Vacuum Pipe Dia. (inch)
SLHR-3U-S	3	600×270×335	4.5	1.5/2	1.5/2
SLHR-3U-ES		745×270×330		1.5/2	1.5/2
SLHR-6U-S	6	565×305×385	7.5	1.5/2	1.5/2
SLHR-6U-ES		730×305×385	9.5	1.5/2	1.5/2
SLHR-12U-S	12	615×335×410	9	1.5/2	1.5/2
SLHR-12U-ES		810×335×410	14	1.5/2	1.5/2
SLHR-24U-S	24	825×335×405	11	2/2.5	2/2.5
SLHR-24U-ES		1255×400×405	15	2/2.5	2/2.5
SLHR-36U-S	36	1094×394×469	12	2/2.5	2/2.5
SLHR-48U-S	48	1242×394×456	18	2/2.5	2.5/3

### SLHR-U-ES base installation dimension

Model	L(mm)	L1(mm)	D(mm)	R(mm)
SLHR-3U-ES	120	50	40	6.5
SLHR-6U-ES	150	70	55	6.5
SLHR-12U-ES	180	80	55	6.5
SLHR-24U-ES	180	85	80	6.5

We reserve the right to change specifications without prior notice.



SHR-P-30U

## ***SHR-P-U Series***

### ■ Coding Principle

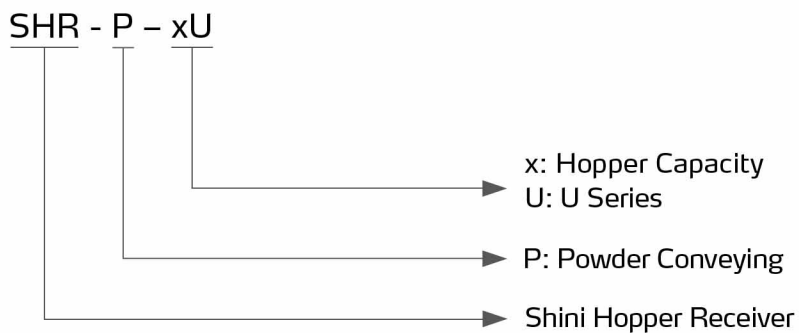

### ■ Features

- This series of power receiver can work with the main vacuum units such as SAL-UGP.
- SHR-P-U consists of two categories, the cloth mesh filter and the plate filter. Cloth mesh filter is used to convey materials with powder content  $\leq 30\%$ , plate filter is used to convey materials with powder content  $> 30\%$ .
- Stainless steel hopper receiver.
- The vacuum valve is used to ensure a good vacuum line without compromising the most demanding conveying capacity.
- All models equipped with auto-purge after each conveying cycle. It maintains a good conveying result and reduces maintenance.

## Accessory

Collective storage hopper SCH-P-30U/60U/90U is available for the SHR-P-30U/60U/90U.

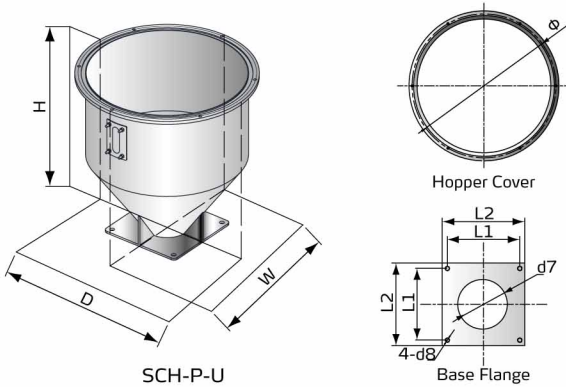

### SCH-P-U

Model	Hopper capacity (L)	Dimension (H×W×D) (mm)	Weight (kg)
SCH-P-30U	30	425 × 470 × 470	9
SCH-P-60U	60	416 × 590 × 590	11
SCH-P-90U	90	536 × 590 × 590	13

### SCH-P-U Flange/Cover

Model	L1 (mm)	L2 (mm)	d5 (mm)	d6 (mm)	Φ (mm)
SCH-P-30U	180	210	Φ100	Φ11	450
SCH-P-60U	180	210	Φ127	Φ11	570
SCH-P-90U	180	210	Φ127	Φ11	570

## Outline Drawings

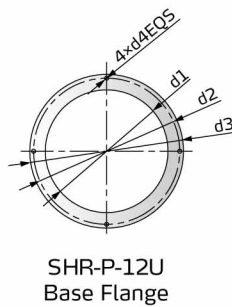
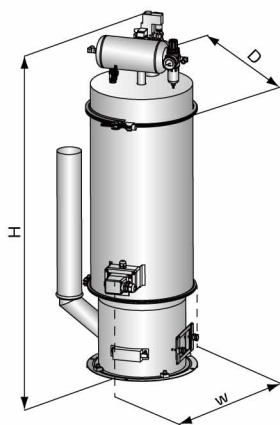

SHR-P-12U  
Base Flange

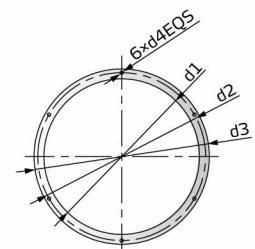
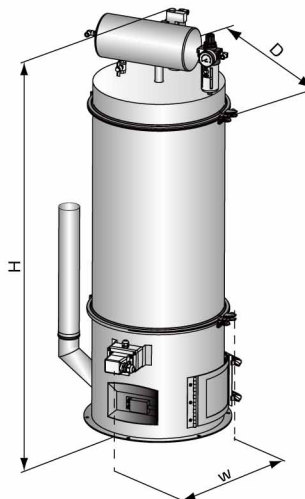

SHR-P-30U~SHR-P-90U  
Base Flange

SHR-P-30U~SHR-P-90U

## Specifications

Model	SHR-P-12U	SHR-P-30U	SHR-P-30U-2	SHR-P-60U	SHR-P-60U-3	SHR-P-90U	SHR-P-90U-5
Hopper capacity (L)	12	30	30	60	60	90	90
H (mm)	1149	1359	1359	1493	1493	1593	1592
W (mm)	450	604	604	700	700	700	700
D (mm)	450	522	522	664	664	664	664
d1 (mm)	280	420	420	542	542	542	542
d2 (mm)	330	450	450	570	570	570	570
d3 (mm)	350	470	470	590	590	590	590
d4 (mm)	Φ9	Φ9	Φ9	Φ9	Φ9	Φ9	Φ9
Weight (kg)	30	41	43	60	63	66	71
Conveying Pipe (inch)	1.5	1.5	1.5	2.0	2.0	2.5	2.5
Vacuum Pipe (inch)	1.5	1.5	1.5	2.0	2.0	2.5	2.5



SHR-CP-U

# SHR-CP-U Series

## ■ Coding Principle

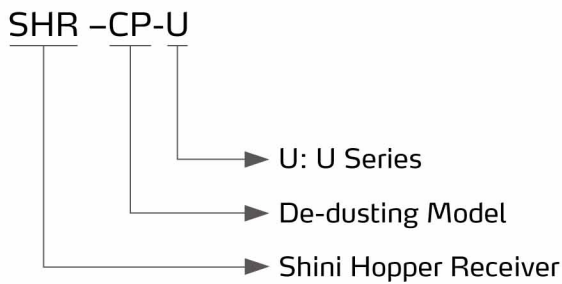

## ■ Features

- SHR-CP-U hopper receiver mainly works with Shini compact dryer SCD or small vacuum units, such as SAL-820G.
- The unique design receiver hopper separated dust from material directly at the glass section. Dust is carried by return airflow back to filter on the main vacuum unit.
- Stainless steel hopper receiver.
- Adjustable material level sensor for the better de-dusting result.

## ■ Specifications

Model	Receiver					Conveying Pipe Dia. (inch)	Vacuum Pipe Dia. (inch)
	Capacity (L)	De-dust efficiency	Capacity (kg/hr)	Dimension (H×W×D) (mm)	Weight (kg)		
SHR-CP-3U	3	80%	10	820 × 280 × 305	8	1.5	1.5

## ■ Outline Drawings

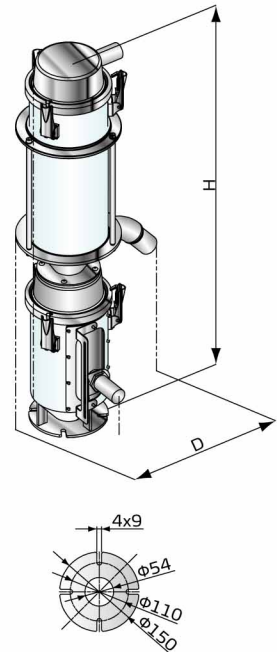

Base Flange



SHR-PB-U

# SHR-PB-U Series

## ■ Coding Principle

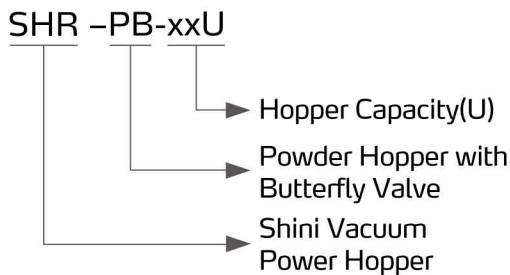

## ■ Outline Drawings

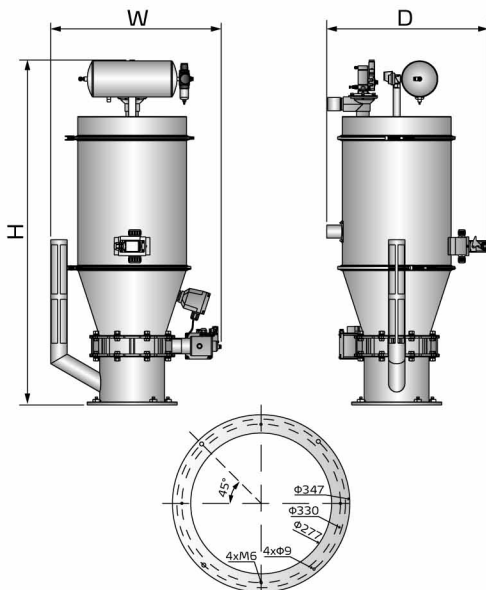

## ■ Features

- This series of product mainly works with the separate-vacuum hopper loader SAL-HP-UGP
- All material contact surfaces are made of stainless steel to eliminate material contamination.
- Adopt butterfly valve with DN250 port to prevent material bridging for quick discharge.
- Adopt sinter-plate filtering with high accuracy that is suitable for powder material conveying
- Equipped with vacuum separation valve can effectively open/close the vacuum circuit
- With an auto cleaner, the filter plate can be automatically cleaned after suction to ensure good ventilation
- Optional gas valve for faster discharge

## ■ Specifications

Model	Capacity (L)	Dimension (H×W×D) (mm)	Weight (kg)	Conveying Pipe Dia. (inch)	Vacuum Pipe Dia. (inch)
SHR-PB-30U	30	1350×660×630	51	2	2
SHR-PB-60U	60	1450×900×860	75	2.5	2
SHR-PB-90U	90	1650×900×860	90	2.5	2.5



## ***SCH(-U)/SICH-U Series***



SICH-6U



SICH-12U



SICH-24U

Refer carefully to the manual before operation.

# SCH(-U)/SICH-U Series

## Coding Principle

S(I)CH-P - xU

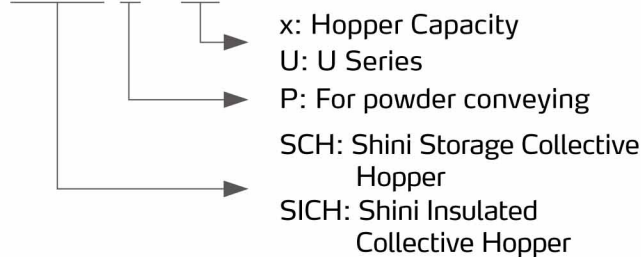

## Features

- Storage collective hopper SCH-U and insulated storage collective hopper SICH-U are mainly used with the vacuum hopper receiver SHR-U and central vacuum hopper receiver SHR-U-S.
- Stainless steel hopper ensures no material contamination.

## Outline Drawings

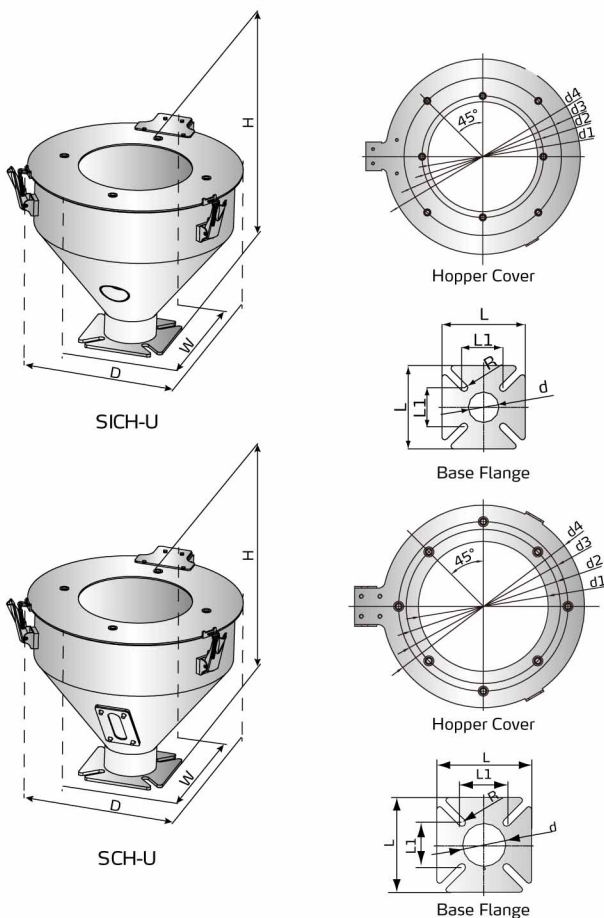

## Specifications

### SICH-U

Model	Hopper capacity (L)	Dimension (H×W×D) (mm)	Weight (kg)
SICH-6U	6	318 × 376 × 408	8
SICH-12U	12	336 × 410 × 450	11
SICH-24U	24	619 × 410 × 450	15

### SICH-U Flange/Cover

Model	L (mm)	L1 (mm)	d (mm)	d1 (mm)	d2 (mm)	d3 (mm)	d4 (mm)	R (mm)
SICH-6U	150	80	61	195	254.5	-	368	6.5
SICH-12U	180	81	77.2	195	254.5	-	409	6.5
SICH-24U	180	81	77.2	230	254.5	330	409	6.5

### SCH-U

Model	Hopper capacity (L)	Dimension (H×W×D) (mm)	Weight (kg)
SCH-6U	6	275 × 320 × 345	4.5
SCH-12U	12	315 × 376 × 408	7
SCH-24U	24	330 × 410 × 450	9
SCH-36U	36	450 × 410 × 450	11

### SCH-U Flange/Cover

Model	L (mm)	L1 (mm)	d (mm)	d1 (mm)	d2 (mm)	d3 (mm)	d4 (mm)	R (mm)
SCH-6U	150	80	58.5	195	231.5	254.5	304	6.5
SCH-12U	150	80	58.5	195	254.5	-	368	6.5
SCH-24U	180	85	81	230	254.5	330	409	7
SCH-36U	180	85	81	230	254.5	330	409	7

## Shini Group

Addr: No. 23, Minhe St., Shulin Dist.,  
New Taipei, Taiwan

Tel: +886 2 2680 9119

Fax: +886 2 2680 9229

Email: [shini@shini.com](mailto:shini@shini.com)

### Factories:

- Taiwan
- Dongguan
- Pinghu
- Ningbo
- Chongqing
- Pune