



Dehumidifying Dryer

SDD-80U/40H



Refer carefully to this manual before operation.

■ Coding Principle

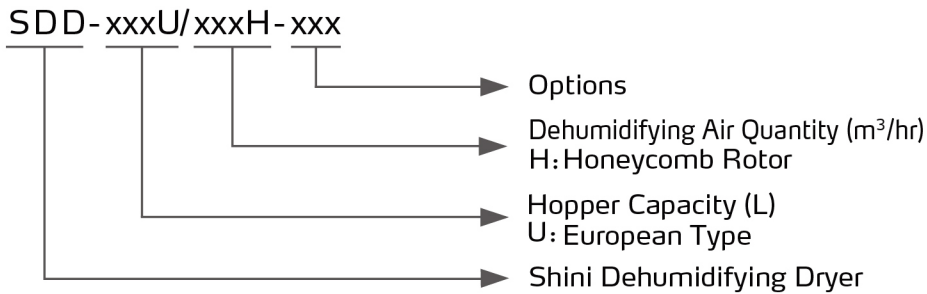

■ Features

- Adopt molecular sieve structure honeycomb, which provides low dew-point dry air. The honeycomb rotor structure is superior to double-barrel dehumidifier that will contaminate raw material due to damaged molecular sieve.
- Dehumidifying and drying function are integrated to ensure high efficiency.
- Insulated drying hopper features dry air down-blowing and cyclone exhaust design. This improves drying efficiency and reduces heat loss, saving energy.
- The dehumidifying section of the SDD series adopts cooler to ensure a low return air temperature and low dew-point.
- Microprocessor is the standard equipment, with a temperature controlling accuracy of $\pm 1^{\circ}\text{C}$.
- Equipped with weekly timer, machine can automatically operate.

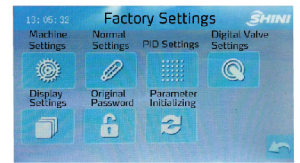

Control Panel

■ Application

SDD dehumidifying dryers integrate dehumidifying and drying into one unit, which mainly process high efficient drying for hygroscopic plastics, such as PET, PA and PC. The floor mounted SDD collocated with loader and suction box beside the IMM can realize auto dehumidifying and drying. Besides, this machine can also be placed at the central material area to work with central material system for centralized drying processing. In addition, there're multiple options and accessories to meet various demands. If some dry materials are volatile, it must use the EOF filter.

1. Photosensor hopper
2. Vacuum pipe
3. Material pipe
4. Vacuum hopper
5. Material storage tank
6. Separate vacuum loader
7. SDD

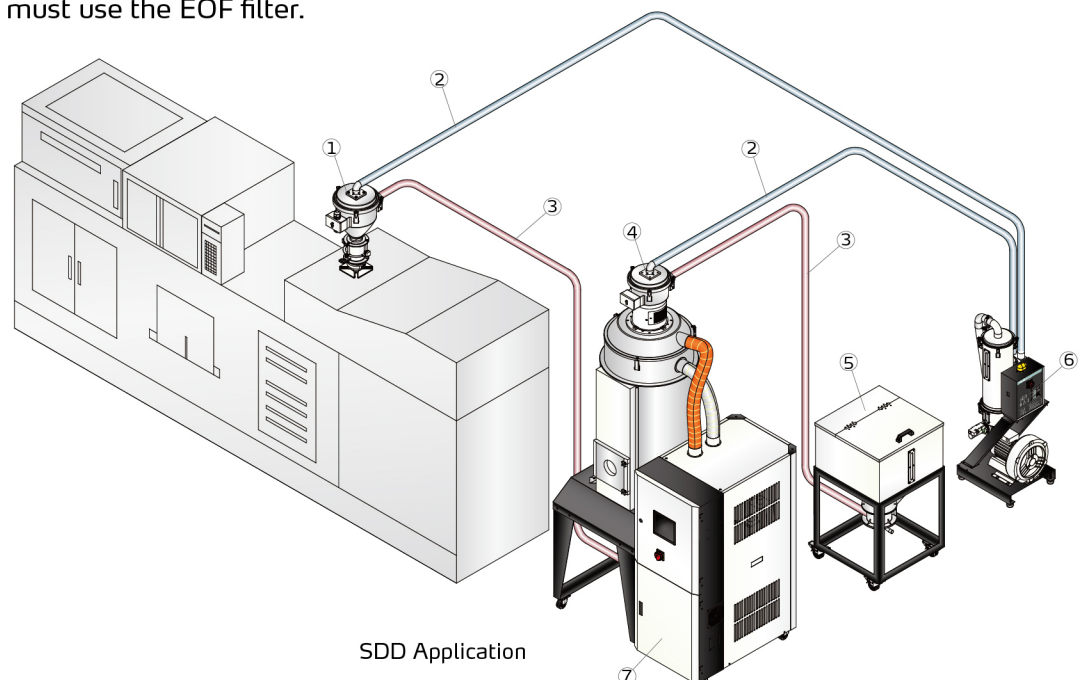

SDD Series

Working Principle

Damp and hot air from dry material barrel is blown into rotor after cooled. Moisture from the air is absorbed by rotor and is then adsorbed by regeneration heating air. Two strands of airflow function on the rotor. And with the rotation, moisture from the air is absorbed and expelled after absorbed regeneration air to form stable low dew-point air, which is dried to the drying temperature and then is blown into material barrel to closed circle to dry material.

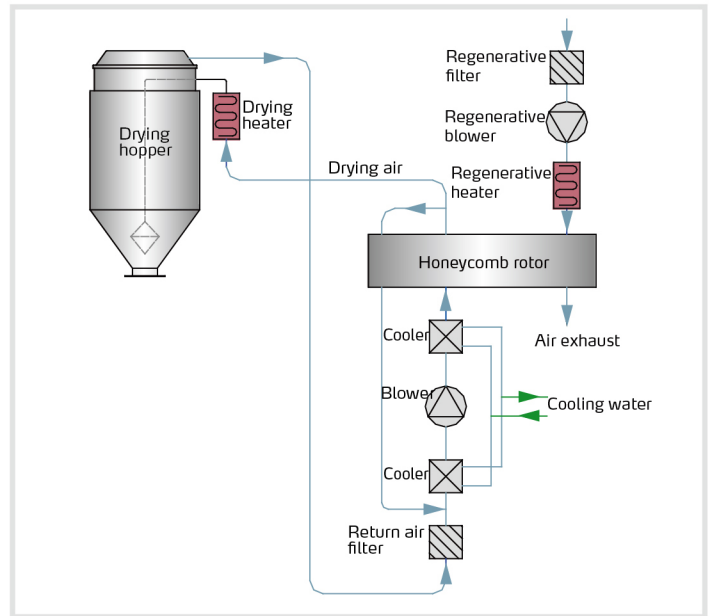

Outline Drawings

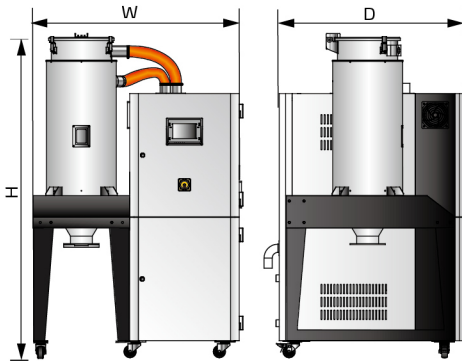

SDD-40U/40H~230U/120H

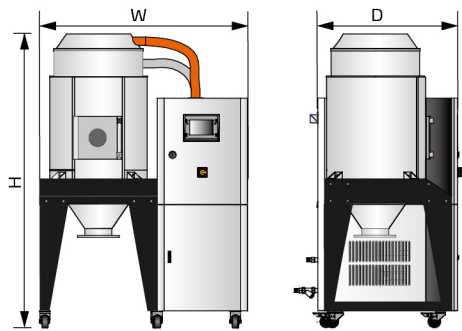

SDD-300U/200H~1200U/700H

Specifications

Model	40U/ 40H	80U/ 40H	120U/ 80H	160U/ 80H	160U/ 120H	230U/ 120H	300U/ 200H	450U/ 200H	600U/ 400H	750U/ 400H	900U/ 700H	1200U/ 700H		
Regen. Heater (kW)	3			4			7.2		10					
Regen. Blower (kW, 50/60Hz)	0.12		0.4				0.75		1.5					
Drying Heater (kW)	4			6			12		18		24			
Drying Blower (kW, 50/60Hz)	0.12		0.75				1.5		3.75		7.5			
Dry Air Volume (m ³ /hr)	40		80		120		200		400		700			
Insulated Hopper	L	40	80	120	160	230	300	450	600	750	900	1200		
	gal	10.6	21	31.7	42.3	60.8	79.3	119	158.5	198	238	317		
Dimension	H	mm	1509	1796	1817	1740	2070	2052	2040	2440	2380	2610	2640	3070
		inch	59.4	70.7	71.5	68.5	81.5	80.8	80.3	96	93.7	102.8	104	121
	W	mm	978	1060	1061	1220	1061	1210	1450	1745	2140			
		inch	38.5	41.7	41.8	48	41.8	47.6	57	68.7	84.3			
D	mm	931	1030	893			1050	1255	1380					
	inch	36.7	40.6	35.2			41.3	49.4	54.3					
Weight	kg	165	190	250	255	265	295	420	550	620	650	830	870	
	lb	364	419	551	562	584	650	926	1213	1367	1433	1830	1918	

Notes: 1) Plastic materials can be fully dried by drying air with dew-point temperature $\leq -20^{\circ}\text{C}$.
2) Power: 3 Φ , 230/400/460/575VAC, 50/60Hz.

Accessories&Options

Dew-point Monitor (portable)



Models with optional portable dew-point monitor is convenient to test dew-point temperature of different machines.

Function	Specification
Display	Digital and Real-time Curve Display supports English\Chinese\Japanese\Korean version.
Range	-50.....+50°C td
	Pressure -0.1.....1.5MPa td
	Temperature -30.....+50°C
Accuracy	Dew point ±2°C td@-50°C td
	Pressure ±0.005MPa
	Temperature ±0.3°C
	Condition temp.: 23°C±3°C Humidity: <90% no condensation
Other Units	g/m ³ , mg/m ³ , ppmv, g/kg
Data Record	Memory space 4G, data can be exported by memory card
	Number of files ≤512 files
	Medium SD card

Oil Filter

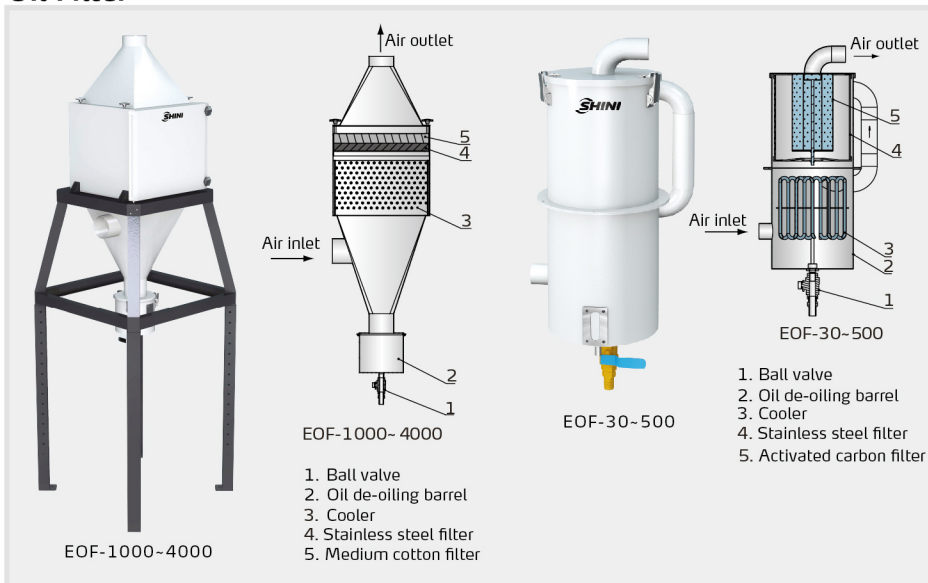

Oil filter is optional to filter the oil substance in return air for honeycomb protection.

Model	Applied to
EOF-30	SD-40H~120H
EOF-150	SD-150H / 200H
EOF-300	SD-300H / 400H
EOF-500	SD-700H
EOF-1000	SD-1000H
EOF-1500	SD-1500H
EOF-2000	SD-2000H
EOF-3000	SD-3000H
EOF-4000	SD-4000H

Accessories

High Efficiency Particulate Absorbing Filter HEPA(0.3µm)



Optical Material Tank (3µm)



For optical model, two devices above are optional to ensure no material contamination.

Optical Powder-removing Hopper

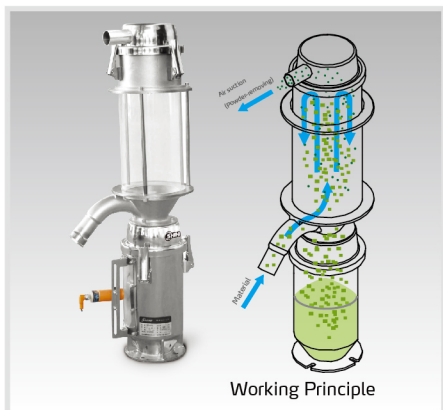

Optical SCD-OP series together with powder-removing hopper which can help avoid stain in the production; material contact surfaces are all mirror polished and collocates conveying system with closed loop to avoid contamination and moisture regain; system has standard configuration high efficiency particulate absorbing filter, which can filter tiny ion of 0.3µm with filter ratio of 99.995%. (Only applicable to SCD-20U/30H~SCD-120U/80H)

Cyclone Dust Collector

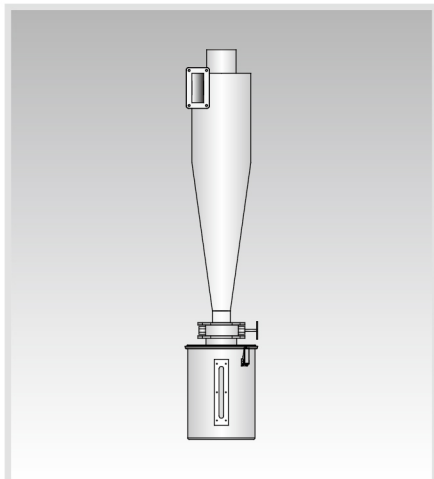

Cyclone dust collector is optional to collect the dust in return air.

Model	Applied to
ACF-3"	SD-300H / 400H
ACF-4"	SD-700H
ACF-5"	SD-1000H
ACF-6"	SD-1500H
ACF-8"	SD-2000H / 3000H
ACF-12"	SD-4000H

- For SD-H, controllable drying heater is optional, add "C" at the end of the model code. (Only Applicable for SD-1000H~4000H)
- For SD-H, inbuilt drying heater is optional, add "PHC" at the end of the model code. (Only applicable for SD-40H~700H)
- For SD-H, intelligent airflow regulating function is optional, add "SM4", "SM8" at the end of the model code, in which the number behind SM depends on the quantity of collocated Modular Dryer. For example, if the quantity of Dryer is less than 4, select SM4 and so on. A touch panel is indispensable if this function is selected. This optional function should work with MHD-U Modular Hopper Dryer, please refer to the dehumidifying and drying modularization.
- For models with energy-saving drying management, add "ES" at model end, standard equipped with HMI touch control, which can reduce 41% of total power consumption at most. Volume used per hour can be set between 40~100% of drying capacity to reduce 35%~0 of totally power consumption;
- Standard equipped with heat regenerating recycler which recycles the heat of exhausted air via plate heat exchanger and can reduce 3%~6% of total power consumption. Meanwhile, dew-point value can be set to automatically control the temperature required by regeneration, saving 0~10% power consumption according to dew-point ranging from -40°C to 10 °C.
- For models with drying heat recycler, add "HE" at the end of model code. Dehumidified low temperature air recycles the heat of hot-wet return air via plate heat exchanger, which can raise the air temperature in drying heater and reduce the power consumption of the heater, as well as reduce 0%~19% of total power consumption. Applicable to SDD and SCD.
- For SCD, three-stage conveying function is available to simultaneously feed two sets of injection molding machines. Add "M2" at the end of the model code.
- For models with polished hopper inside, add "P" at the end of the model code.