

2.3 Assembly Drawing

2.3.1 Assembly Drawing

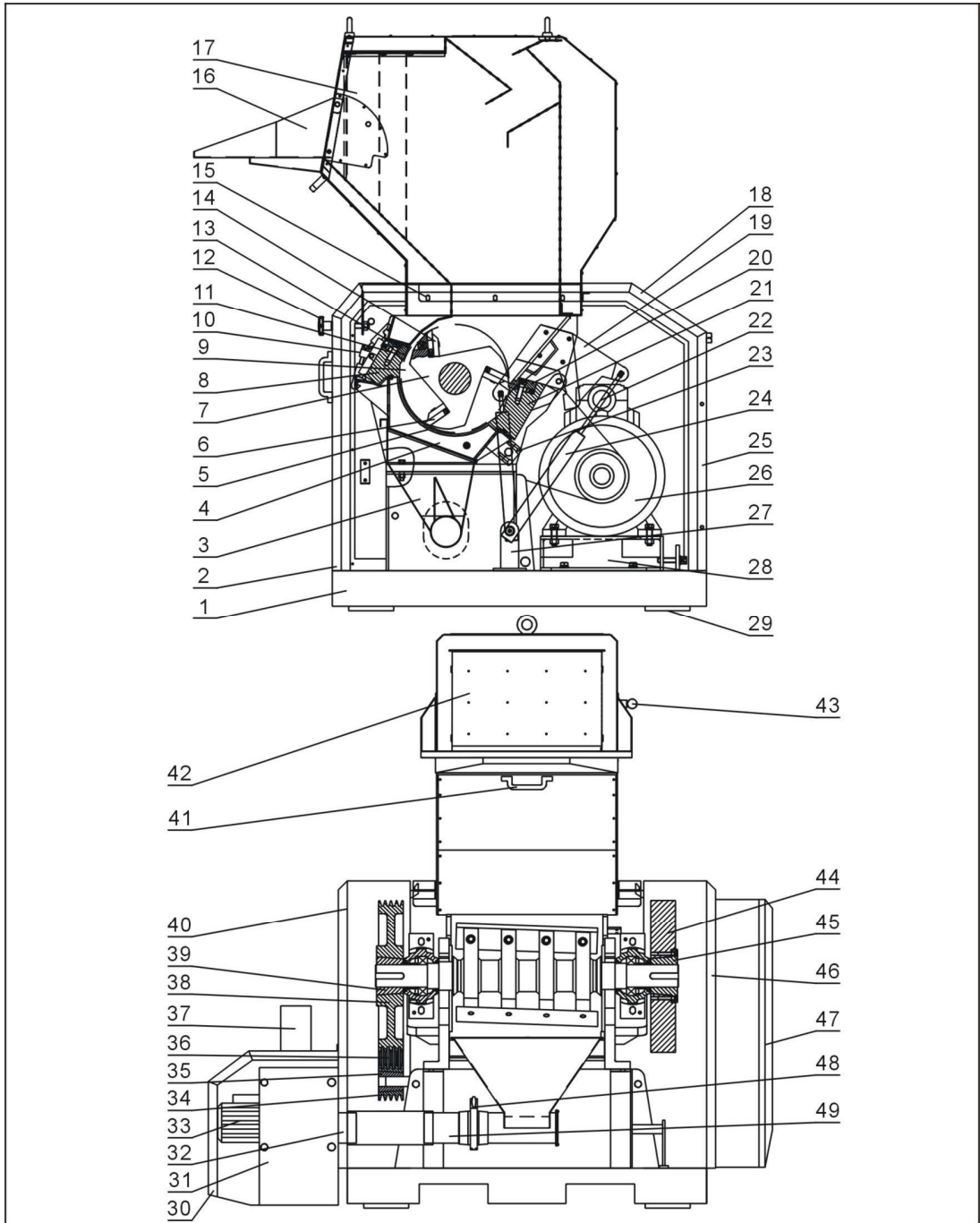

Note: Please refer to 2.3.2 material list about the parts code.

Picture 2-7: Assembly Drawing

2.3.2 Parts List

Chart 2-1: Parts List

No.	Name	Part No.	
		SG-3650	SG-3675
1	Frame	-	-
2	Front door	-	-
3	Storage box	-	-
4	Screen bracket	-	-
5	Screen **	BL55365000220	BL55367502020
6	Rotating blade **	BW40365000710	BW42367510010
7	Blade rest	BH11365000710	BH11367512010
8	Front block	BW30365000410	BW30367504010
9	Insert block	BL55364501021	BL55364501021
10	Square block	BH10362600010	BH10362600010
11	Fixed blade **	BW40365000610	BW42367509010
12	Star knob	-	-
13	Front pressing block	BH10365000510	BH10367508110
14	Rotating blade press plate	BH11365000810	BH11367511010
15	Base shelf of feeding hopper	-	-
16	Feed opening	-	-
17	Feed box	-	-
18	After top cover board	-	-
19	Spring fixing plate	-	-
20	Back pressing block	BH10365000110	BH10367513010
21	Back block	BW30365001110	BW30367514010
22	Pneumatic spring	YW01140000000	YW01160000000
23	Sieve net frame pin when a linking piece	-	-
24	Sleeve	-	-
25	Under cover plate after	-	-
26	Motor	YM10418300200	YM10420700200
27	Spring fixing plate	-	-
28	Motor installed base	-	-
29	Anti-vibration pad	-	-
30	Blower cover	-	-
31	Blower stents components	-	-
32	Side cover over	-	-
33	Blower *	BM30112200050	BM30152300050
34	Small belt pulley	YW30180400000	YW30180400000
35	Small belt pulley taper sleeve	YW30254800000	YW30255500000

No.	Name	Part No.	
		SG-3650	SG-3675
36	V belt *	YR00059000000	YR00059000000
37	Blower flange	-	-
38	Big belt pulley	YW30500400000	YW30500400000
39	Big belt pulley taper sleeve	YW30353507500	YW30353507500
40	Left side plate	-	-
41	Handle	BW20012000140	BW20012000140
42	Material fender	-	-
43	Spring bolt in feeding port	-	-
44	Flywheel	BW30003600110	BW30003600110
45	Flywheel hood	BW30036000010	BW30036000010
46	Right side plate	-	-
47	Door of control box	-	-
48	Stainless steel pipe clamp 4"	YW07000400000	YW07000400000
49	Blower connection pipe	-	-

* means possible broken parts.

** means easy broken part. and spare backup is suggested.

Please confirm the version of manual before placing the purchase order to guarantee that the item number of the spare part is in accordance with the real object.

2.3.3 Cutting Chamber

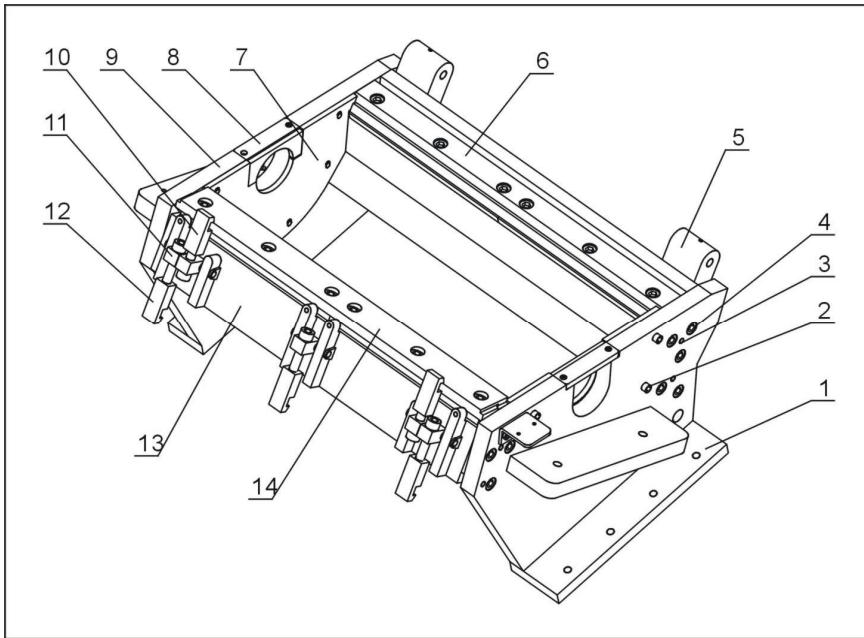

Picture 2-8: Cutting Chamber

2.3.4 Cutting Chamber Parts List

Chart 2-2: Cutting Chamber Parts List

No.	Name	Quantity
1	Right side plate	1
2	Inner hexagon socket cap screw M10 × 50	10
3	Column pin 10 × 50	8
4	Inner hexagon socket cap screw M16 × 50	16
5	Back block	1
6	Back pressing block	1
7	Insert block	2
8	Sidewall block ring	2
9	Left side plate	1
10	Feed box iron hook	2
11	Square block	4
12	Screen bracket iron hook	2-3
13	Front block	1
14	Front pressing block	1

2.3.5 BladeRest

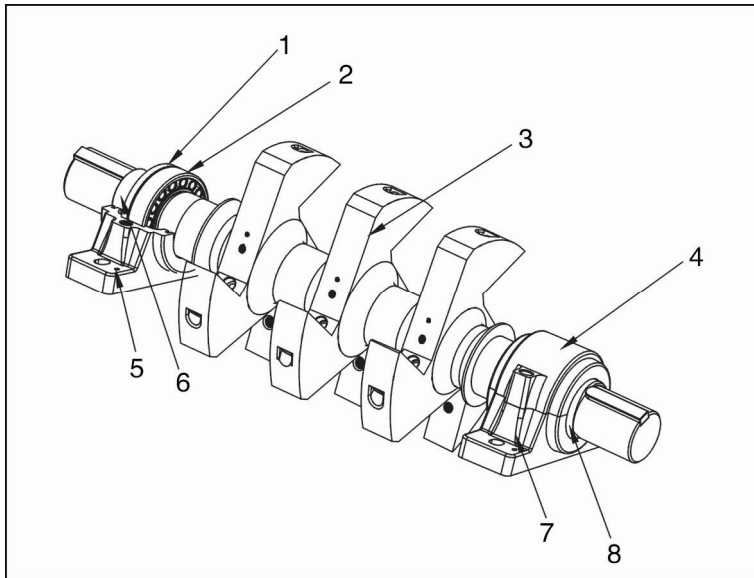

Picture 2-9: BladeRest

2.3.5.1 BladeRest Parts List

Chart 2-3: BladeRest Parts List

No.	Name	Quantity
1	Bearing thrust ring	2
2	Bearing 22215EAE4	2
3	Knife shaft	1
4	Bearing the upper	2
5	Position localized bolt	4
6	Shaft sleeve	2
7	Housings nakedness	2
8	Oil seal TSN215G	4

2.3.6 Transmission Parts

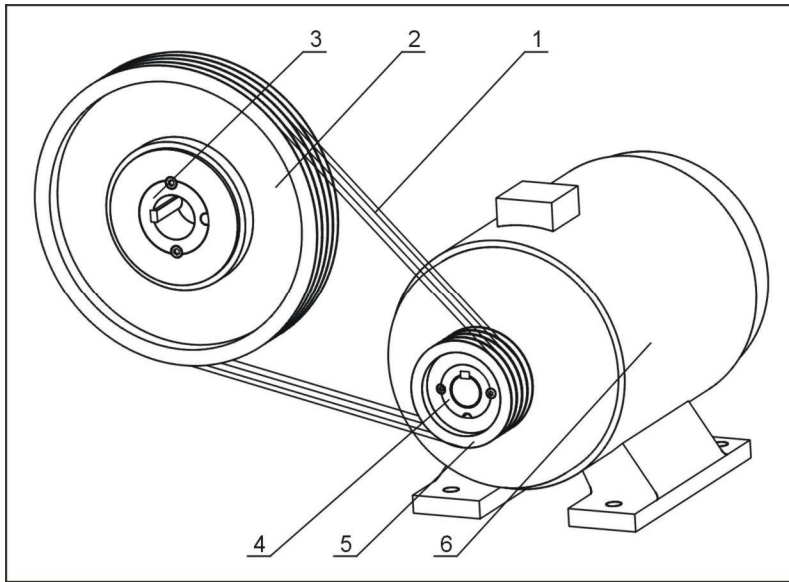

Picture 2-10: Transmission Parts

2.3.7 Transmission Parts List

Chart 2-4: Transmission Parts Parts List

No.	Name	Quantity
1	V belt	4
2	Big belt pulley SPB500X4	1
3	Taper sleeve 3535 ϕ 75	1
4	Taper sleeve 2517 ϕ 55	1
5	Small belt pulley SPB180X4	1
6	Motor	1

2.3.8 Screen

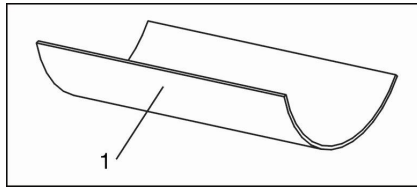

Picture 2-11: Screen

2.3.9 Screen Parts List

Chart 2-5: Screen Parts List

No.	Name	Quantity
1	Screen	1

2.3.10 Screen Bracket

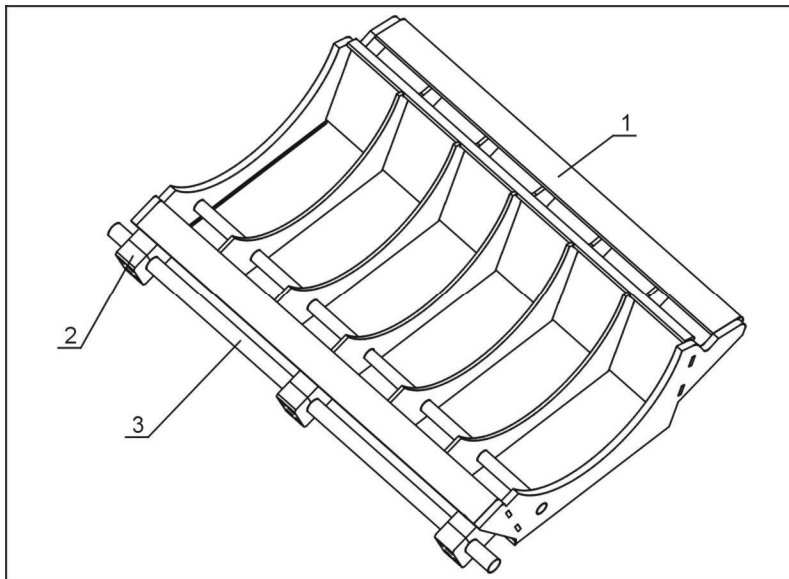

Picture 2-12: Screen Bracket

2.3.11 Screen Bracket Parts List

Chart 2-6: Screen Bracket Parts List

No.	Name	Quantity
1	Screen bracket	1
2	Screen bracket shaft pin press plate	2-3
3	Screen bracket shaft pin	1

2.3.12 Blower

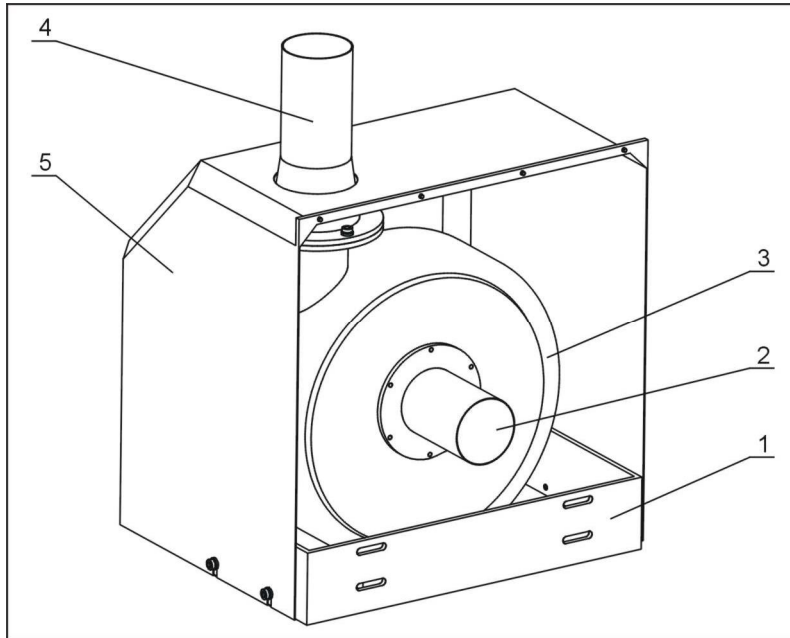

Picture 2-13: Blower

2.3.13 Blower Parts List

Chart 2-7: Blower Parts List

No.	Name	Quantity
1	Blower stents	1
2	Side cover over	1
3	Blower	1
4	Blower flange and take over	1
5	Blower cover	1

2.3.14 Feed Box, Insulative Box and Shutter

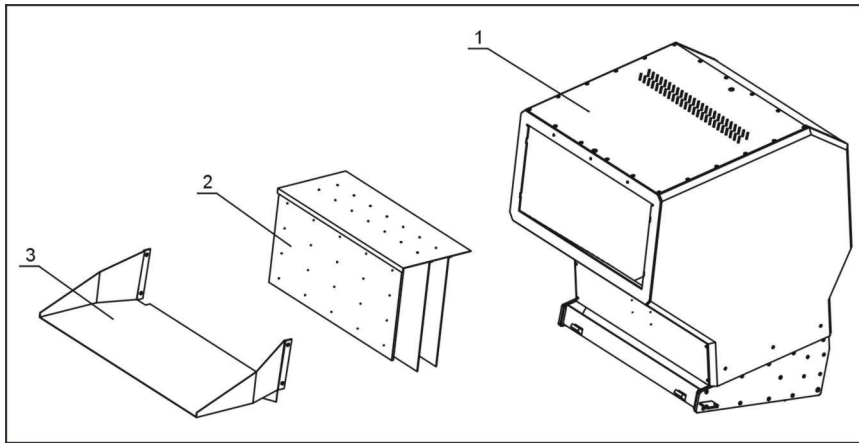

Picture 2-14: Feed Box, Insulative Box and Shutter

2.3.15 Feed Box, Insulative Box and Shutter Parts List

Chart 2-8: Feed Box, Insulative Box and Shutter Parts List

No.	Name	Quantity
1	Feed box	1
2	Material fender	1
3	Feed opening	1

2.3.16 Storage box

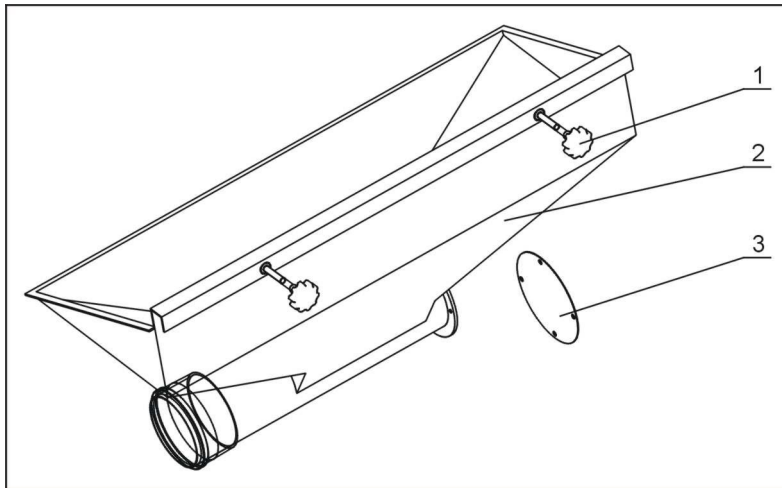

Picture 2-15: Storage box

2.3.17 Storage box Parts List

Chart 2-9: Storage box Parts List

No.	Name	Quantity
1	Five-star handle B typeM8 X35	2
2	Storage box	1
3	Flange	1

2.3.18 Main Body

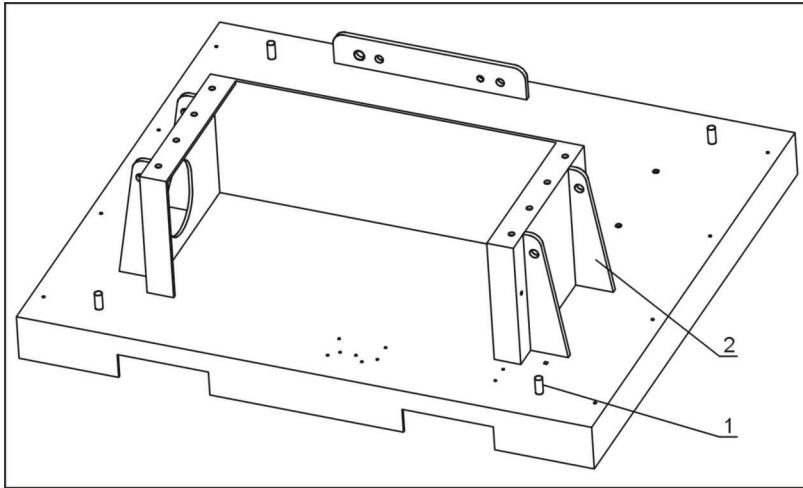

Picture 2-16: Main Body

2.3.19 Main Body Parts List

Chart 2-10: Main Body Parts List

No.	Name	Quantity
1	Anti-vibration pad screw shaft	4
2	Base	1