

2.2 Assembly Drawing

2.2.1 Assembly Drawing (SAL-1HP/2HP-UG122)

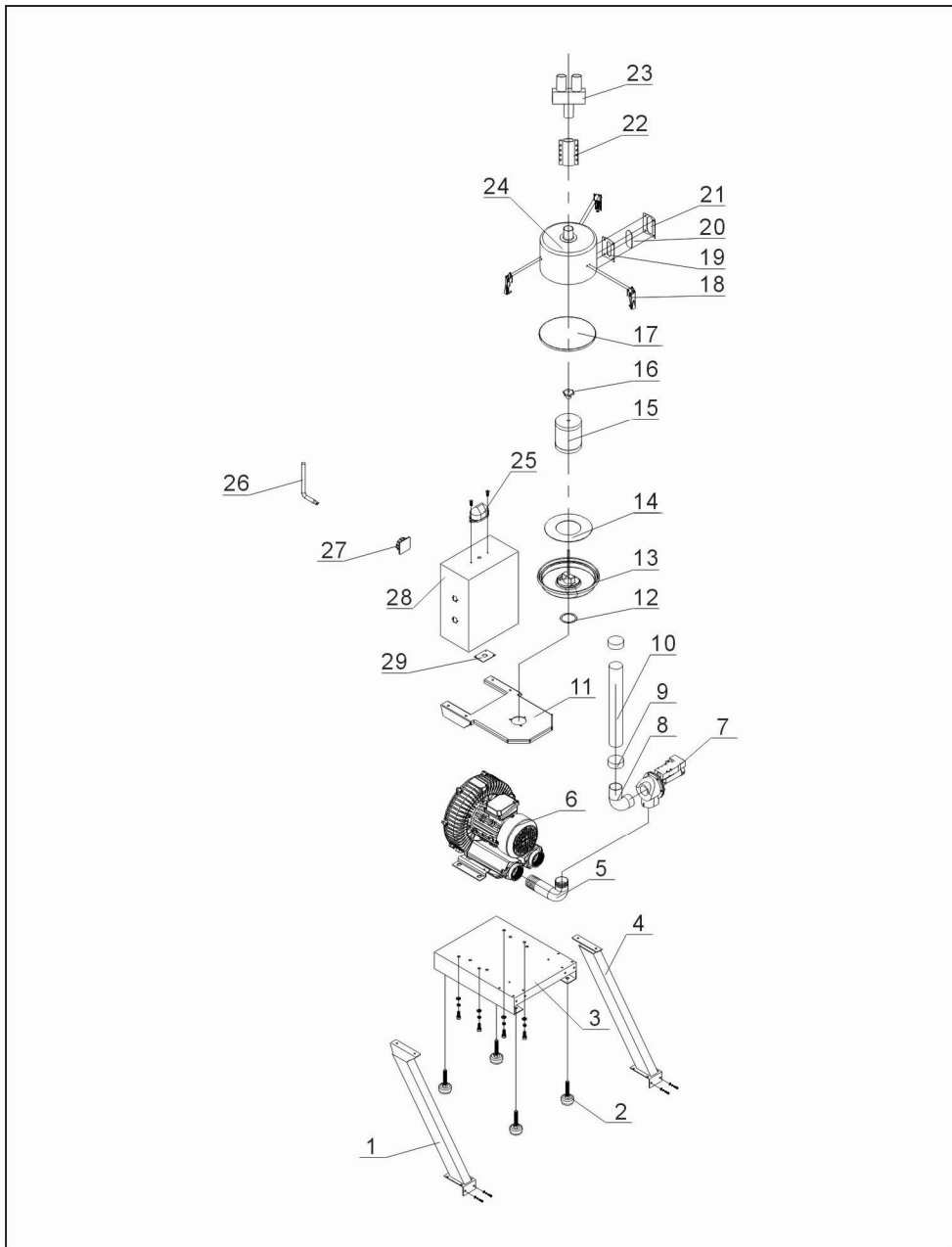

Remarks: Please refer to material list 2.2.2 for specific explanation of the Arabic numbers in parts drawing.

Picture 2-2: Assembly Drawing (SAL-1HP/2HP-UG122)

2.2.2 Parts List (SAL-1HP/2HP-UG122)

Table 2-1: Parts List (SAL-1HP/2HP-UG122)

No.	Name	Part No.	No.	Name	Part No.
1	Left standing pole	-	15	Filter	YR50708000000
2	Anti-vibration pad	YW03005000000	16	Hexagon nut 5/16"	YW69051600000
3	Base	-	17	Filter fastener	YR10708000100
4	Right stand column	-	18	Snap hook	YW02003000400
5	Air inlet pipe	-	19	Four hole material window fastener	YW09000000400
6	High-pressure blower 1HP	BM30031000150	20	Four acryl	YR40001200100
	High-pressure blower 2HP	BM30042000050	21	Four hole material windw sheet iron	YR40000400000
7	Vacuum breaking diaphragm valve 1.5"	BY20015000050	22	Pipe connector 2"	BW20002002050
8	Vacuum-breaking diaphragm valve piping	-	23	T-branch pipe	-
9	Tube bundle 2.5"	YW02002500000	24	Filter barrel	-
10	Steel wired plastic pipe 2"	YR60205040100	25	Alarm light	YE83305100200
11	Supporting structure of filter barrel	-	26	Dedicated wrench for anti-theft screw	JT40450000000
12	Filter barrel base fastener	-	27	Main power switch	YE10210300000
13	Filter barrel lid assembly	-	28	Control cabinet	BH32012040050
14	Filter barrel lid fastener	YR10030000000	29	Line jig fixed plate	-

* means possible broken parts. ** means easy broken part. and spare backup is suggested. Please confirm the version of manual before placing the purchase order to make sure that the item number of the spare part is in accordance with the real object.

2.2.3 Assembly Drawing (SAL-3.5HP/5HP(-D)-122)

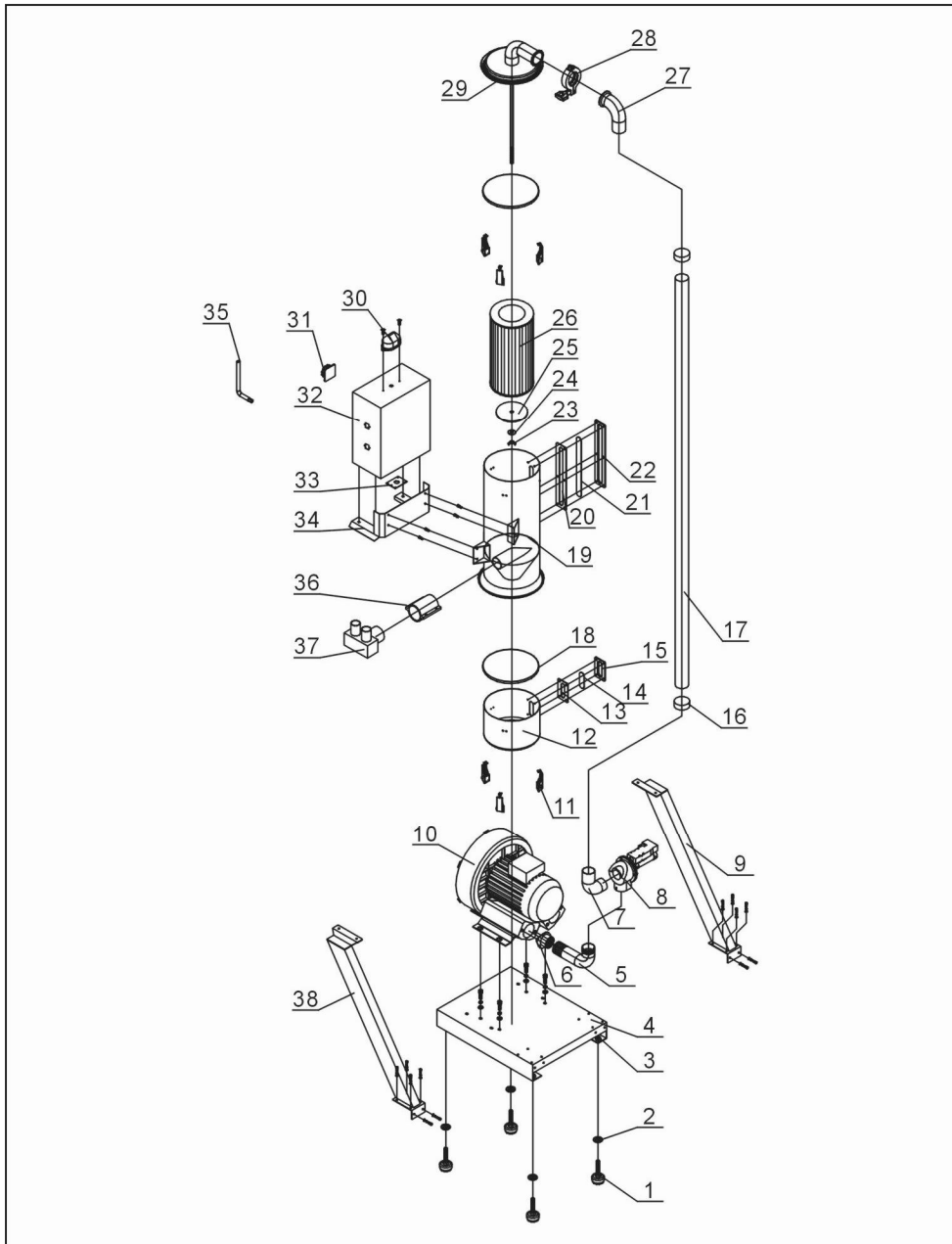

Remarks: Please refer to material list 2.2.4 for specific explanation of the Arabic numbers in parts drawing.

Picture 2-3: Assembly Drawing (SAL-3.5HP/5HP(-D)-UG122)

2.2.4 Parts List (SAL-3.5HP/5HP (-D)-UG122)

Table 2-2: Parts List (SAL-3.5HP/5HP (-D)-UG122)

No.	Name	Part No.	No.	Name	Part No.
1	Anti-vibration pad Φ 50	YW03005000000	19	Filter barrel roll	-
2	Flat washer 8	YW66082200100	20	Six hole material window fastener	YR40000600000
3	Nut M12	YW64012100000	21	Six acryl	YR40001200000
4	Base	BL21003500120	22	Six hole material windw sheet iron	YW09000600000
5	Air inlet pipe	BL26003506520-	23	Butterfly nut 5/16"	YW69051600000
6	Blower flange	-	24	Flat washer 8	YW66082200100
7	Vacuum-breaking diaphragm valve 1.5"	BY20015000050	25	Strainer fixed plate	BL26003502520
8	Vacuum-breaking diaphragm valve piping	-	26	Filter ADC2	YR50181100000
9	Right stand column	-	27	Air suction pipe	-
10	High pressure blower 3.5HP	BM30053500050	28	Pipe clamp	YW07000200000
	High pressure blower 5HP	BM30055000050	29	Filter barrel lid assembly	-
	High pressure blower 5HP (double stage)	YM30433700000	30	Alarm light LTE-3051 AC220V	YE83305100200
11	Snap hook	YW02003000400	31	Main power switch	YE10210300000
12	Dust collecting barrel	BL26003507021	32	Control cabinet	-
13	Four hole material window fastener	YR40000400000	33	Line jig fixed plate	-
14	Four hole acryl	YR40001200100	34	Supporting structure of filter barrel	-
15	Four hole material window sheet iron	YW09000000400	35	Dedicated wrench for anti-theft screw	JT40450000000
16	Pipe bundle 2.5"	YW02002500000	36	Pipe connector2"	YW20002000700
17	Steel wire rubber pipe 2"	YR60205040100	37	T-branch pipe	-
18	Dust collecting barrel fastener	YR10708000100	38	Left stand column	-

* means possible broken parts. ** means easy broken part. and spare backup is suggested. Please confirm the version of manual before placing the purchase order to make sure that the item number of the spare part is in accordance with the real object.

2.2.5 Assembly Drawing (SAL-7.5HP/10HP (-D)-UG122)

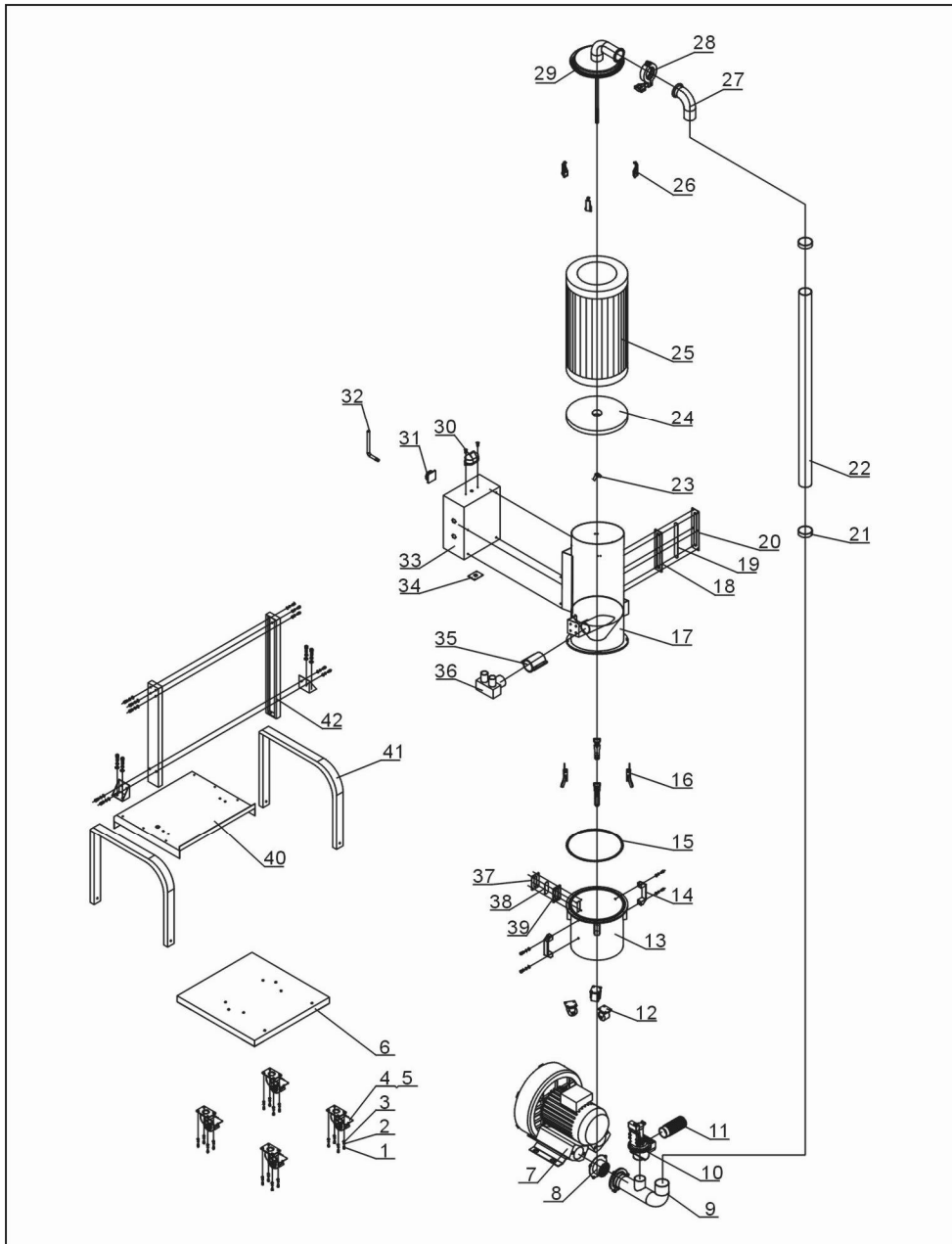

Remarks: Please refer to material list 2.2.6 for specific explanation of the Arabic numbers in parts drawing.

Picture 2-4: Assembly Drawing (SAL-7.5HP/10HP (-D)-UG122)

2.2.6 Parts List (SAL-7.5HP/10HP (-D)-UG122)

Table 2-3: Parts List (SAL-7.5HP/10HP (-D)-UG122)

No.	Name	Part No.	No.	Name	Part No.
1	Outer hexagon bolt M6×16	YW60061600100	21	Stainless steel pipe bundle 3"	YW02000300000
2	Flat washer 6	YW66061300000	22	Steel wire rubber pipe 2.5"	YR60253000000
3	Spring washer 6	YW65006000100	23	Butterfly nut 5/16"	YW69051600000
4	Brake universal caster 3"	YW03000300000	24	Strainer fixed plate	BL26007504720
5	Freestyle universal caster 3"	YW03000300200	25	Filter	YR50221400000
6	Base	BL26007502721	26	Snap hook	YW02003000400
7	High pressure blower 7.5HP	BM30075000050	27	Air suction pipe	-
	High pressure blower 7.5HP(two stage)	YM30635500000	28	Pipe clamp	YW07002500600
	High pressure blower 10HP	BM30081000050	29	Filter barrel lid assembly	-
	High pressure blower 10HP(two stage)	YM30637500000	30	Alarm light	YE83305100200
8	Blower flange	-	31	Main power switch	YE10210300000
9	Air inlet pipe	-	32	Dedicated wrench for anti-theft screw	JT40450000000
10	Vacuum separating valve 2"	BY20500000050	33	Control cabinet	-
11	Air refill screen	-	34	Line jig fixed plate	-
12	Universal caster 2.5"	YW03002500000	35	Pipe connector 2.5"	BH80002510050
13	Dust collecting barrel	BL26007502421	36	T-branch pipe	-
14	Aluminum handle L120	BW20012000040	37	Four hole material window fastener	YW09000000400
15	Dust collecting barrel fastener	YE32051800100	38	Four hole acryl	YR40000400000
16	Big handle	YW02003000100	39	Four hole material window sheet iron	YR40001200100
17	Filter barrel assembly	-	40	Intermediate plate	-
18	Six hole material window fastener	YR40000600000	41	Frame 1	-
19	Six acryl	YR40001200000	42	Stand column for filter barrel	-
20	Six hole material window sheet iron	YW09000600000			

* means possible broken parts. ** means easy broken part. and spare backup is suggested. Please confirm the version of manual before placing the purchase order to make sure that the item number of the spare part is in accordance with the real object.

2.2.7 Parts Drawing (SHR-3U-S)

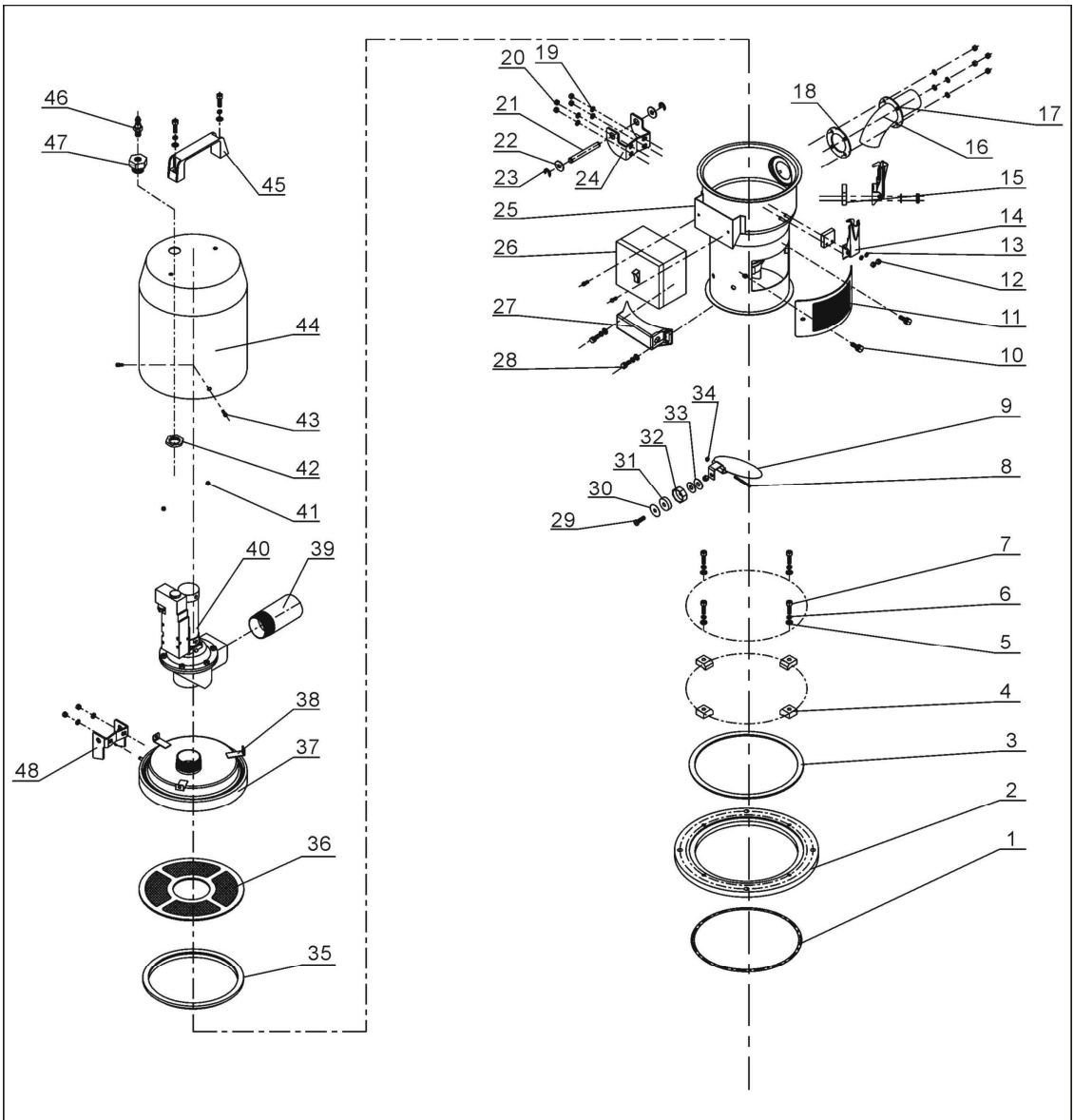

Notes: Please refer to material list 2.2.8 for specific explanation of the Arabic numbers in parts drawing.

Picture 2-5: Parts (SHR-3U-S)

2.2.8 Parts List (SHR-3U-S)

Table 2-4: Parts List (SHR-3U-S)

No.	Name	Part No.	No.	Name	Part No.
1	Inner diameter of O type seal ringΦ200×5.5	YR20205500000	25	Material storage tank	-
2	Base	BW20171200010	26	Control box	BH90615000010
3	Base fastener	-	27	Sensor shell	YR40000601100
4	Pressure block	BW20000630500	28	Inner hexagon cylinder head screw M6×10	YW63061000000
5	Flat gasket 6	YW66061300000	29	Cross recess pan head screw M3×25	YW63032500000
6	Spring gasket 6	YW65006000000	30	Flat gasket 8×22	YW66082200100
7	Inner hexagon cylinder head screw M6×20	YW61062000300	31	Permanent magnet Φ21×Φ3×7	YW90213700000
8	Cross recess pan head screw M3×40	YW63034000000	32	Magnet sleeve	BH12115000010
9	Discharge port	-	33	Flat gasket 3×12	YW66031200000
10	Star knob	YR40061500000	34	Locknut M3	YW64000300000
11	Ventilation window	YR40000601000	35	Hopper fastener	YR10001500000
12	Locknut M4×0.7	YW64040700100	36	Filter screen	BL20000300120
13	Flat gasket 4	YW66040800000	37	Hopper cover	-
14	Snap hook	YW02003000400	38	Motor cover fixing base	BL21001501320
15	Snap hook pad	YR40000600800	39	Air suction pipe	-
16	Material inlet pipe	-	40	Vacuum separating valve SPDV-38	-
17	Material inlet pipe fixing plate	-	41	Locknut M6	YW64000600200
18	Material inlet pipe fastener	YR10150300000	42	Connecting nut	BH12003600410
19	Flat gasket 5	YW66051000100	43	Cross recess pan head screw M5×15	YW62051500000
20	Locknut M5	YW64000500000	44	Diaphragm valve cover	-
21	Hinge pin	BH10006003110	45	Aluminum square handle L120	BW20012000040
22	Flat gasket 8×22	YW66082200100	46	Quick connector SPC8-1/4	YW80081400000
23	E rings 6	YW66000500000	47	Connection copper head	BH12002400010
24	Down hinge	BL32000600140	48	Up hinge	BL32000600240

* means possible broken parts. ** means easy broken part. and spare backup is suggested. Please confirm the version of manual before placing the purchase order to make sure that the item number of the spare part is in accordance with the real object.

2.2.9 Parts Drawing (SHR-6U-S)

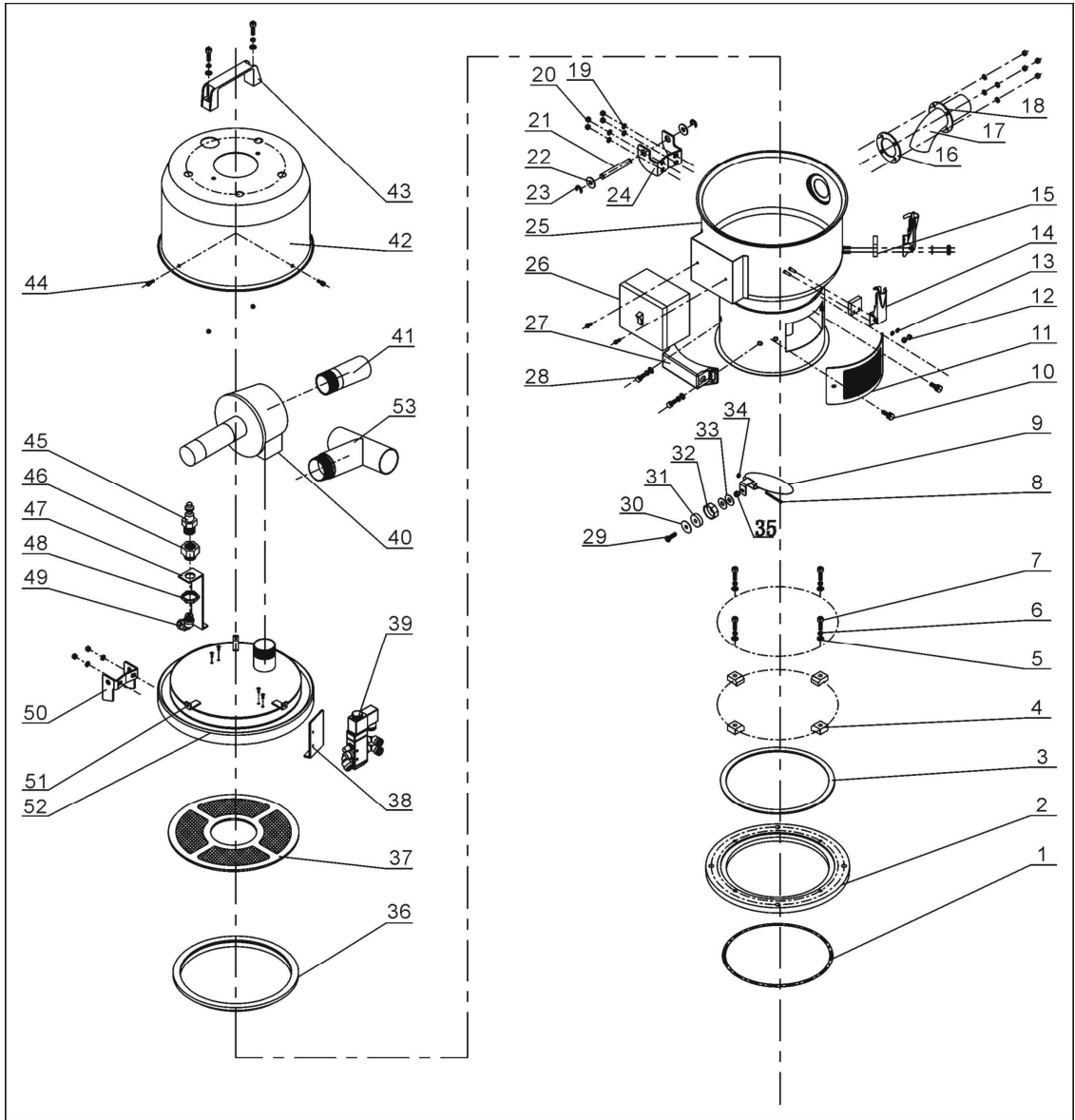

Notes: Please refer to material list 2.2.10 for specific explanation of the Arabic numbers in parts drawing.

Picture 2-6: Parts (SHR-6U-S)

2.2.10 Parts List (SHR-6U-S)

Table 2-5: Parts List (SHR-6U-S)

No.	Name	Part No.	No.	Name	Part No.
1	Inner diameter of O type seal $\Phi 200 \times 5.5$	YR20205500000	28	Inner hexagon cylinder head screw M6 \times 10	YW63061000000
2	Base	BW20171200010	29	Cross recess pan head screw M6 \times 20	YW63062000000
3	Base fastener	-	30	Magnet cover	BL21000600120
4	Pressure block	BW20000630500	31	Permanent magnet $\Phi 21 \times \Phi 3 \times 7$	YW90257700000
5	Flat gasket 6	YW66061300000	32	Magnet sleeve	BH12000600010
6	Spring gasket 6	YW65006000000	33	Flat gasket 8 \times 22	YW66082200100
7	Inner hexagon cylinder head screw M6 \times 20	YW61062000200	34	Locknut M3	YW64000300000
8	Cross recess pan head screw M3 \times 40	YW63034000000	35	Locknut M6	YW64000600200
9	Discharge plate	BL21000302320	36	Hopper fastener	YR10000300100
10	Star knob	YR40061500000	37	Filter screen	BL21000600620
11	Ventilation window	YR40000601000	38	Solenoid valve fixing plate	BL27000601120
12	Locknut M4 \times 0.7	YW64040700100	39	Solenoid valve	YE32051800100
13	Flat gasket 4	YW66040800000	40	Diaphragm valve 1.5"	-
14	Snap hook	YW40000600800	41	Air suction pipe	-
15	Snap hook pad	YR40000600300	42	Motor cover	BR40033000110
16	Material inlet pipe fastener	YR10150300000	43	Aluminum square handle L120	BW20012000040
17	Material inlet pipe	-	44	Cross recess pan head screw M5 \times 15	YW62051500000
18	Material inlet pipe fixing plate	-	45	Quick connector 3" \times 1/4PT	YW80031400000
19	Flat gasket 5	YW66051000100	46	Connection copper head	BH12002400010
20	Locknut M5	YW64000500000	47	Air pipe connector fixing block	BL27000601520
21	Hinge pin	BH10006003110	48	Connecting nut	BH12003600410
22	Flat gasket 8 \times 22	YW66082200100	49	Quick connector APL8-1/4PT	YW80081400100
23	E rings 8	YW69896800000	50	Up hinge	BL32000600240
24	Down hinge	BL32000600140	51	Motor cover fixing base	BL21001501320
25	Material storage tank	-	52	Hopper cover	-
26	Control box	BH90615000010	53	T-branch air suction pipe (optional)	-
27	Sensor shell	YR40000601100			

* means possible broken parts. ** means easy broken part. and spare backup is suggested. Please confirm the version of manual before placing the purchase order to make sure that the item number of the spare part is in accordance with the real object.

2.2.11 Parts Drawing (SHR-12U-S)

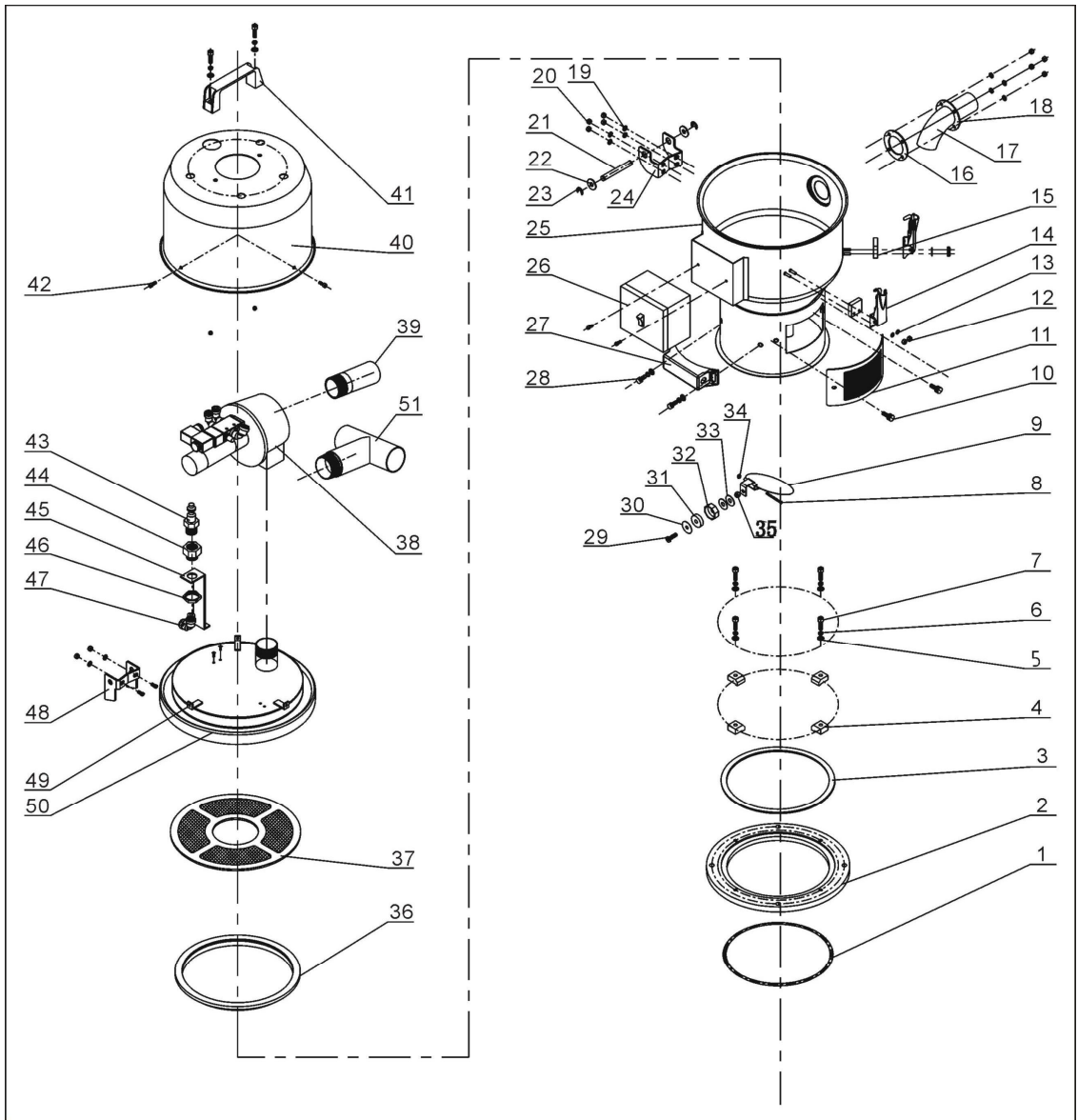

Notes: Please refer to material list 2.2.12 for specific explanation of the Arabic numbers in parts drawing.

Picture 2-7: Parts (SHR-12U-S)

2.2.12 Parts List (SHR-12U-S)

Table 2-6: Parts List (SHR-12U-S)

No.	Name	Part No.	No.	Name	Part No.
1	Inner diameter of O type seal ring $\Phi 200 \times 5.5$	YR20205500000	27	Sensor shell	YR40000601100
2	Base	BW20171200010	28	Inner hexagon cylinder head screw M6 \times 10	YW63061000000
3	Base fastener	-	29	Cross recess pan head screw M6 \times 20	YW63062000000
4	Pressure block	BW20000630500	30	Magnet cover	BL21000600120
5	Flat gasket 6	YW66061300000	31	Permanent magnet $\Phi 21 \times \Phi 3 \times 7$	YW90257700000
6	Spring gasket 6	YW65006000000	32	Magnet sleeve	BH12000600010
7	Inner hexagon cylinder head screw M6 \times 20	YW61062000200	33	Flat gasket 8 \times 22	YW66082200100
8	Cross recess pan head screw M3 \times 40	YW63034000000	34	Locknut M3	YW64000300000
9	Discharge port	-	35	Locknut M6	YW64000600200
10	Star knob	YR40061500000	36	Hopper fastener	YR10000600200
11	Ventilation window	YR40000601000	37	Filter screen	BL21001200320
12	Locknut M4 \times 0.7	YW64040700100	38	Diaphragm valve 1.5"	-
13	Flat gasket 4	YW66040800000	39	Air suction pipe	-
14	Snap hook	YW02003000400	40	Motor cover	BR40036000310
15	Snap hook pad	YR40000600800	41	Aluminum square handle L120	BW20012000040
16	Material inlet pipe fastener	YR10061200000	42	Cross recess pan head screw M5 \times 15	YW62051500000
17	Material inlet pipe	-	43	Quick connector 3" \times 1/4PT	YW80031400000
18	Material inlet pipe fixing plate	-	44	Connection copper head	BH12002400010
19	Flat gasket 5	YW66051000100	45	Air pipe connector fixing block	-
20	Locknut M5	YW64000500000	46	Connecting nut	BH12003600410
21	Hinge pin	BH10006003110	47	Quick connector APL8-1/4PT	YW80081400100
22	Flat gasket 8 \times 22	YW66082200100	48	Up hinge	BL32000600240
23	E rings 8	YW69896800000	49	Motor cover fixing base	BL21001501320
24	Down hinge	BL32000600140	50	Hopper cover	-
25	Material storage tank	-	51	T-branch air suction pipe (optional)	-
26	Control box	BH90615000010			

* means possible broken parts. ** means easy broken part. and spare backup is suggested. Please confirm the version of manual before placing the purchase order to make sure that the item number of the spare part is in accordance with the real object.

2.2.13 Parts Drawing (SHR-24U-S)

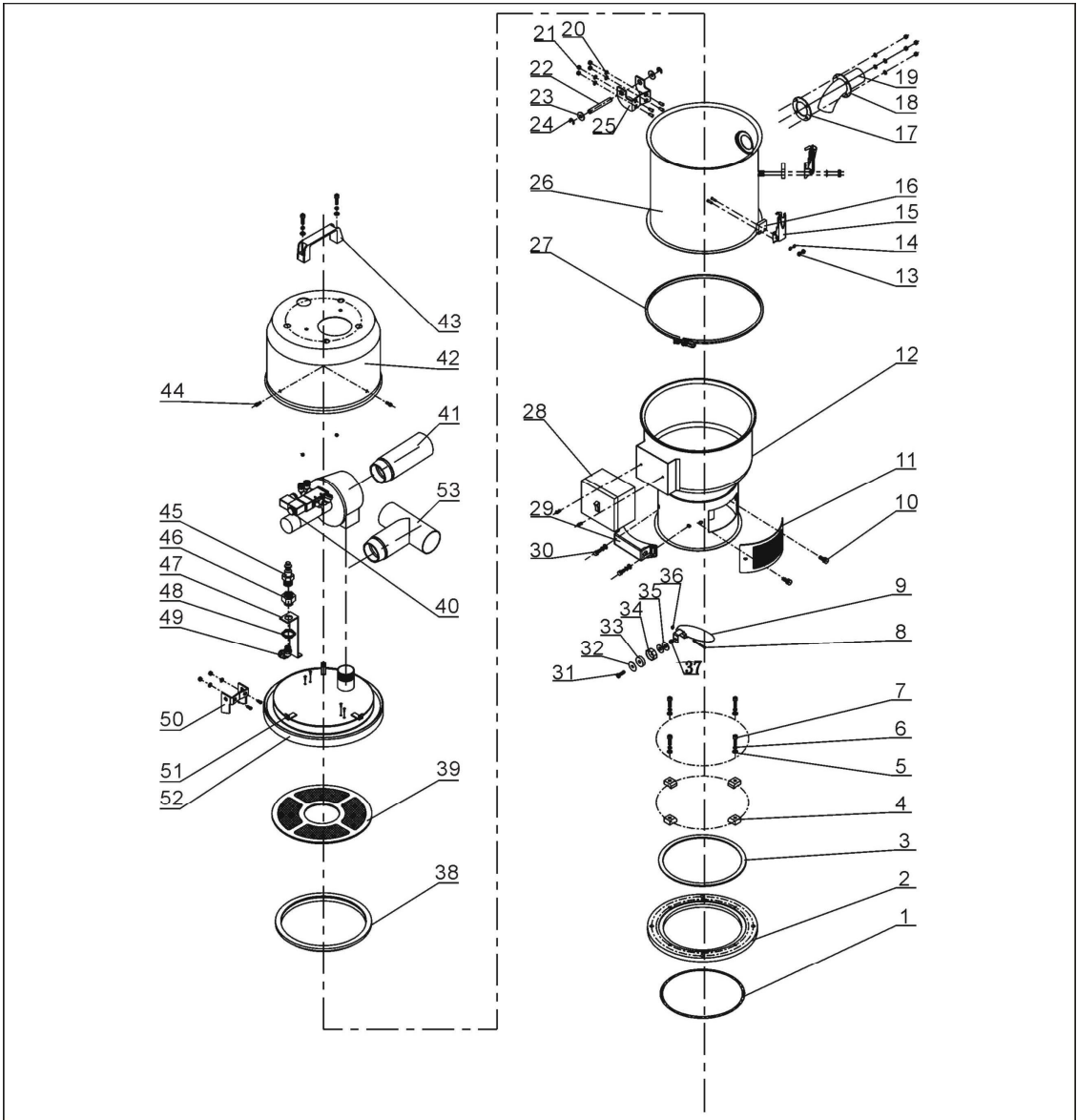

Notes: Please refer to material list 2.2.14 for specific explanation of the Arabic numbers in parts drawing.

Picture 2-8: Parts (SHR-24U-S)

2.2.14 Parts List (SHR-24U-S)

Table 2-7: Parts List (SHR-24U-S)

No.	Name	Part No.	No.	Name	Part No.
1	Inner diameter of O type seal ring $\Phi 200 \times 5.5$	YR20205500000	28	Control box	BH90615000010
2	Base	BW20171200010	29	Sensor shell	YR40000601100
3	Base fastener	-	30	Inner hexagon cylinder head screw M6 \times 10	YW63061000000
4	Pressure block	BW20000630500	31	Cross recess pan head screw M6 \times 20	YW63062000000
5	Flat gasket 6	YW66061300000	32	Magnet cover	BL21000600120
6	Spring gasket 6	YW65006000000	33	Permanent magnet $\Phi 21 \times \Phi 3 \times 7$	YW90257700000
7	Inner hexagon cylinder head screw M6 \times 20	YW61062000200	34	Magnet sleeve	BH12000600010
8	Cross recess pan head screw M3 \times 40	YW63034000000	35	Flat gasket 8 \times 22	YW66082200100
9	Discharge port	-	36	Locknut M3	YW64000300000
10	Star knob	YR40061500000	37	Locknut M6	YW64000600200
11	Ventilation window	YR40000601000	38	Hopper fastener	YR10000300100
12	Material storage tank	-	39	Filter screen	BL21001200320
13	Locknut M4 \times 0.7	YW64040700100	40	Diaphragm valve 2"	-
14	Flat gasket 4	YW66040800000	41	Air suction pipe	-
15	Snap hook	YW02003000400	42	Motor cover	BR40036000310
16	Snap hook pad	YR40000600800	43	Aluminum square handle L120	BW20012000040
17	Material inlet pipe fastener	YR10150300000	44	Cross recess pan head screw M5 \times 15	YW62051500000
18	Material inlet pipe fixing plate	-	45	Quick connector 3" \times 1/4PT	YW80031400000
19	Material inlet pipe	-	46	Connection copper head	BH12002400010
20	Flat gasket 5	YW66051000100	47	Air pipe connector fixing block	-
21	Locknut M5	YW64000500000	48	Connecting nut	BH12003600410
22	Hinge pin	BH10006003110	49	Quick connector APL8-1/4PT	YW80081400100
23	Flat gasket 8 \times 22	YW66082200100	50	Up hinge	BL32000600240
24	E rings 8	YW69896800000	51	Motor cover fixing base	BL21001501320
25	Down hinge	BL32000600140	52	Hopper cover	-
26	Enlarged material tank	-	53	T-branch air suction pipe (optional)	-
27	Pipe clamp	-			

* means possible broken parts. ** means easy broken part. and spare backup is suggested. Please confirm the version of manual before placing the purchase order to make sure that the item number of the spare part is in accordance with the real object.

2.2.15 Parts Drawing (SHR-36U-S)

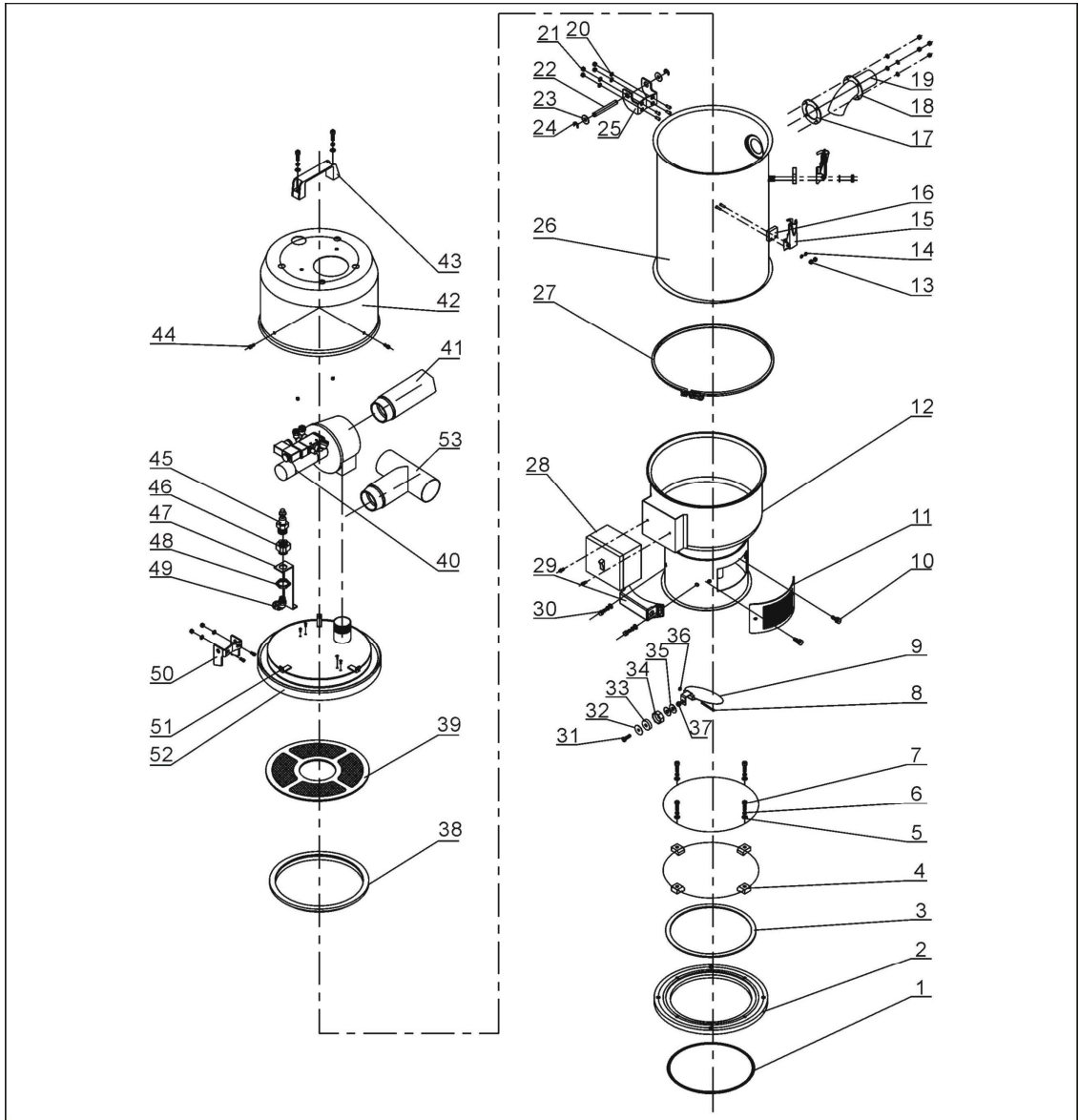

Notes: Please refer to material list 2.2.16 for specific explanation of the Arabic numbers in parts drawing.

Picture 2-9: Parts (SHR-36U-S)

2.2.16 Parts List (SHR-36U-S)

Table 2-8: Parts List (SHR-36U-S)

No.	Name	Part No.	No.	Name	Part No.
1	Inner diameter of O type seal ring $\Phi 200 \times 5.5$	YR20205500000	28	Control box	BH90615000010
2	Base	BW20171200010	29	Sensor shell	YR40000601100
3	Base fastener	-	30	Inner hexagon cylinder head screw M6 \times 10	YW63061000000
4	Pressure block	BW20000630500	31	Cross recess pan head screw M6 \times 20	YW63062000000
5	Flat gasket 6	YW66061300000	32	Magnet cover	BL21000600120
6	Spring gasket 6	YW65006000000	33	Permanent magnet $\Phi 21 \times \Phi 3 \times 7$	YW90257700000
7	Inner hexagon cylinder head screw M6 \times 20	YW61062000200	34	Magnet sleeve	BH12000600010
8	Cross recess pan head screw M3 \times 40	YW63034000000	35	Flat gasket 8 \times 22	YW66082200100
9	Discharge plate	-	36	Locknut M3	YW64000300000
10	Star knob	YR40061500000	37	Locknut M6	YW64000600200
11	Ventilation window	YR40000601000	38	Hopper fastener	YR10000300100
12	Material storage tank	-	39	Filter screen	BL21001200320
13	Locknut M4 \times 0.7	YW64040700100	40	Diaphragm valve 2"	-
14	Flat gasket 4	YW66040800000	41	Air suction pipe	-
15	Snap hook	YW02003000400	42	Motor cover	BR40036000310
16	Snap hook pad	YR40000600800	43	Aluminum square handle L120	BW20012000040
17	Material inlet pipe fastener	YR10243600000	44	Cross recess pan head screw M5 \times 15	YW62051500000
18	Material inlet pipe fixing plate	-	45	Quick connector 3" \times 1/4PT	YW80031400000
19	Material inlet pipe	-	46	Connection copper head	BH12002400010
20	Flat gasket 5	YW66051000100	47	Air pipe connector fixing block	-
21	Locknut M5	YW64000500000	48	Connecting nut	BH12003600410
22	Hinge pin	BH10006003110	49	Quick connector APL8-1/4PT	YW80081400100
23	Flat gasket 8 \times 22	YW66082200100	50	Up hinge	BL32000600240
24	E rings 8	YW69896800000	51	Motor cover fixing base	BL21001501320
25	Down hinge	BL32000600140	52	Hopper cover	-
26	Enlarged material tank	-	53	T-branch air suction pipe (optional)	-
27	Pipe clamp	-			

* means possible broken parts. ** means easy broken part. and spare backup is suggested. Please confirm the version of manual before placing the purchase order to make sure that the item number of the spare part is in accordance with the real object.

2.2.17 Parts Drawing (SHR-3U-ES)

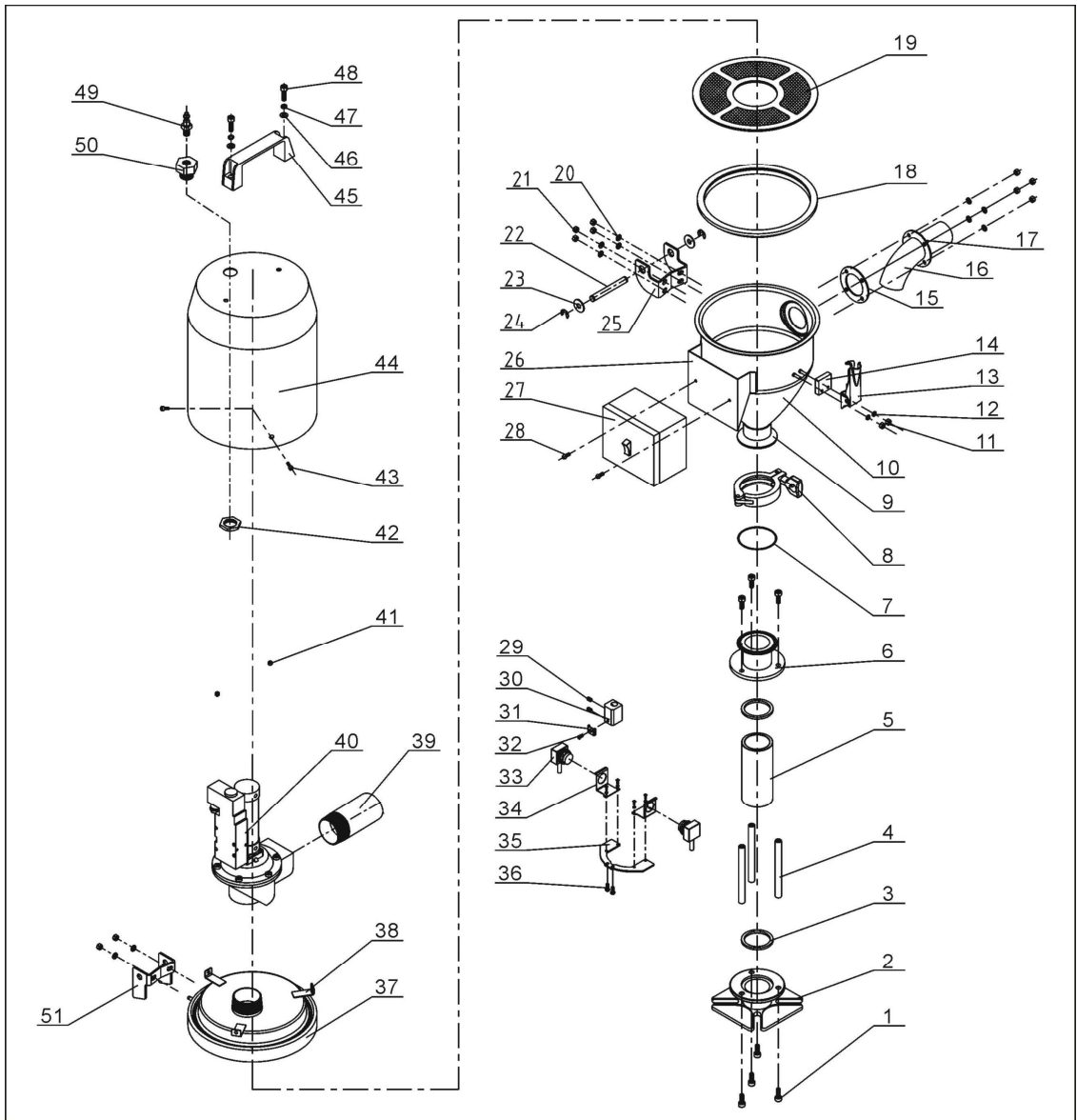

Notes: Please refer to material list 2.2.18 for specific explanation of the Arabic numbers in parts drawing.

Picture 2-10: Parts (SHR-3U-ES)

2.2.18 Parts List (SHR-3U-ES)

Table 2-9: Parts List (SHR-3U-ES)

No.	Name	Part No.	No.	Name	Part No.
1	Inner hexagon cylinder head screw M6×15	YW61061600300	27	Control box	BH90615000010
2	Down flange of glass pipe	BW32000300010	28	Cross recess pan head screw M4×10	YW63041000000
3	Glass pipe fastener	YR10000300000	29	Set screw M4×5	YW68004500000
4	Flange connection shaft	BH11030400540	30	Photosensor fixing base	BL90001000120
5	Glass pipe Φ50.5×Φ40.5×111	YW70504000000	31	Photosensor cable pressure block	YW31616200000
6	Up flange of glass pipe	BW32000300210	32	Cross recess pan head screw M4×10	YW63041000000
7	Base fastener	YR10000300200	33	Photosensor FOTEK T18-3MN-PE	YE15143900000
8	2"Stainless steel pipe clamp	YW07000200000	34	Photosensor mounting plate	-
9	Hopper flange	-	35	Photosensor fixing plate	-
10	Material storage tank	-	36	Cross recess pan head screw M4×10	YW63041000000
11	Locknut M4×0.7	YW64040700100	37	Hopper cover	-
12	Flat gasket 4	YW66040800000	38	Motor cover fixing base	BL21001501320
13	Snap hook	YW02003000400	39	Air suction pipe	-
14	Snap hook pad	YR40000600800	40	Vacuum separating valve SPDV-38	-
15	Material inlet pipe fastener	YR10150300000	41	Locknut M6	YW64000600200
16	Material inlet pipe	-	42	Connecting nut	BH12003600410
17	Material inlet pipe fixing plate	-	43	Cross recess pan head screw M5×15	YW62051500000
18	Hopper fastener	YR10001500000	44	Diaphragm valve cover	-
19	Filter screen	BL20000300120	45	Aluminum square handle L120	BW20012000040
20	Flat gasket 5	YW66051000100	46	Flat gasket 6	YW66061300000
21	Locknut M5	YW64000500000	47	Spring gasket 6	YW65006000000
22	Hinge pin	BH10006003110	48	Inner hexagon cylinder head screw M6×20	YW61062000300
23	Flat gasket 8×22	YW66082200100	49	Quick connector SPC8-1/4	YW80081400000
24	E rings 6	YW66000500000	50	Connection copper head	BH12002400010
25	Down hinge	BL32000600140	51	Up hinge	BL32000600240
26	Control box base	-			

* means possible broken parts. ** means easy broken part. and spare backup is suggested. Please confirm the version of manual before placing the purchase order to make sure that the item number of the spare part is in accordance with the real object.

2.2.19 Parts Drawing (SHR-6U-ES)

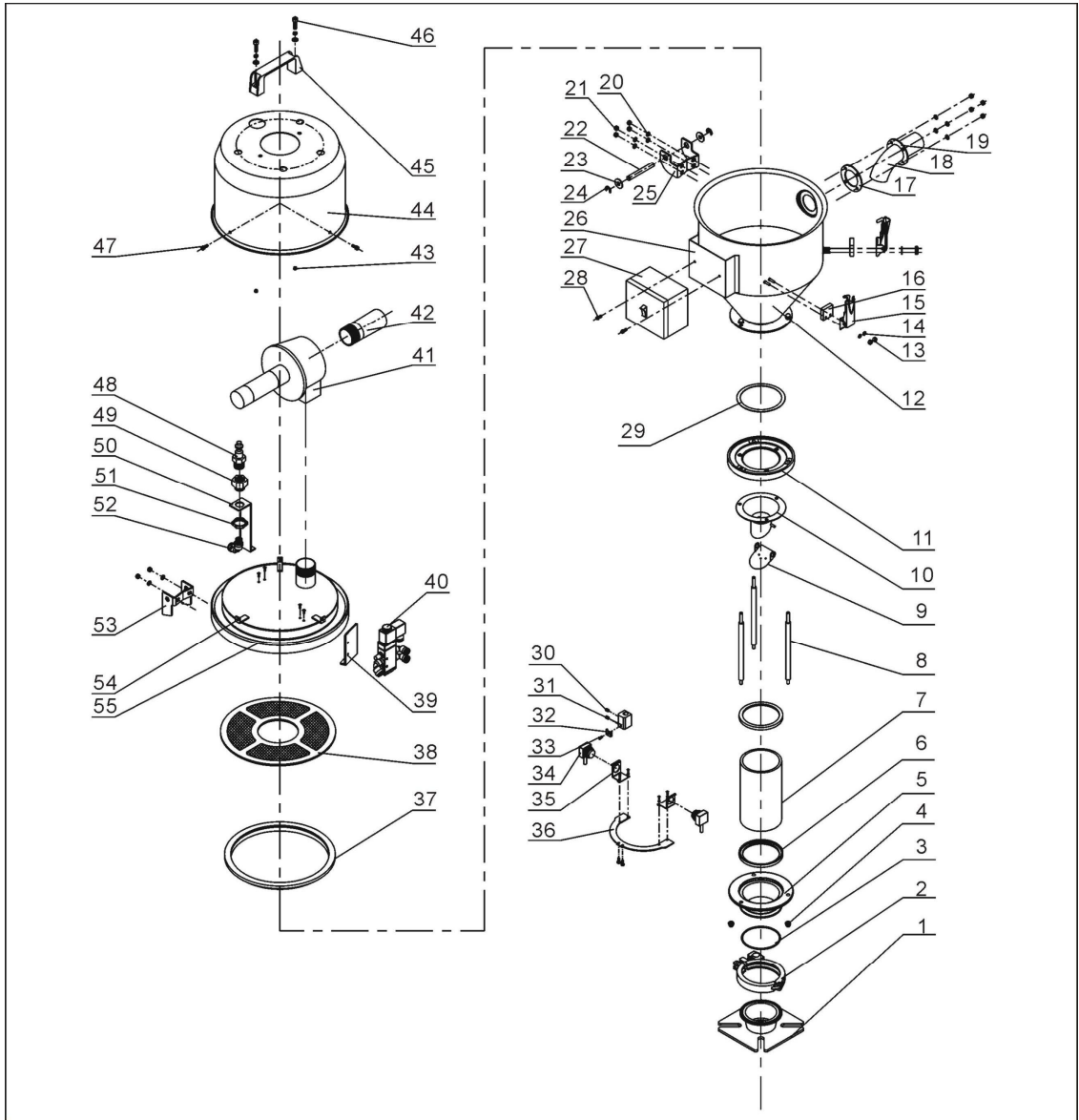

Notes: Please refer to material list 2.2.20 for specific explanation of the Arabic numbers in parts drawing.

Picture 2-11: Parts (SHR-6U-ES)

2.2.20 Parts List (SHR-6U-ES)

Table 2-10: Parts List (SHR-6U-ES)

No.	Name	Part No.	No.	Name	Part No.
1	Mounting flange	BL21060200820	29	Cross recess pan head screw M4×6	YW63040600000
2	3" Stainless steel pipe clamp	YW07000300000	30	Set screw M4×5	YW68004500000
3	O type seal ring	YR20802600000	31	Photosensor fixing base	BL90001000120
4	Cap nut M6	YW64006000100	32	Photosensor cable pressure block	YW31616200000
5	Down flange of glass pipe	BW32610900010	33	Cross recess pan head screw M4×10	YW63041000000
6	Glass pipe fastener	YR10060200000	34	Photosensor	YE15143900000
7	Glass pipe	YW70317000600	35	Photosensor mounting plate	-
8	Flange connection shaft	BH10000600640	36	Photosensor fixing plate	BL21061200020
9	Non-return flap	-	37	Hopper fastener	YR10000300100
10	Discharge port	-	38	Filter screen	BL21000600620
11	Up flange of glass pipe	BW32610800010	39	Solenoid valve fixing plate	-
12	Material storage tank	-	40	Solenoid valve	YE32051800100
13	Locknut M4×0.7	YW64040700100	41	Diaphragm valve 1.5"	-
14	Flat gasket 4	YW66040800000	42	Air suction pipe	-
15	Snap hook	YW02003000400	43	Locknut M6	YW64000600200
16	Pad	YR40000600800	44	Motor cover	BR40033000110
17	Material inlet pipe fastener	YR10150300000	45	Aluminum square handle L120	BW20012000040
18	Material inlet pipe	-	46	Inner hexagon cylinder head screw M6×20	YW61062000300
19	Material inlet pipe fixing plate	-	47	Cross recess pan head screw M5×15	YW62051500000
20	Flat gasket 5	YW66051000100	48	Quick connector 3" ×1/4PT	YW80031400000
21	Locknut M5	YW64000500000	49	Connection copper head	BH12002400010
22	Hinge pin	BH10006003110	50	Air pipe connector fixing block	-
23	Flat gasket 8×22	YW66082200100	51	Connecting nut	BH12003600410
24	E rings 8	YW69896800000	52	Quick connector	YW80081400100
25	Down hinge	BL32000600140	53	Up hinge	BL32000600240
26	Control box base	-	54	Motor cover fixing base	BL21001501320
27	Control box	BH90615000010	55	Hopper cover	-
28	Hopper base plate fastener	-			

* means possible broken parts. ** means easy broken part. and spare backup is suggested. Please confirm the version of manual before placing the purchase order to make sure that the item number of the spare part is in accordance with the real object.

2.2.21 Parts Drawing (SHR-12U-ES)

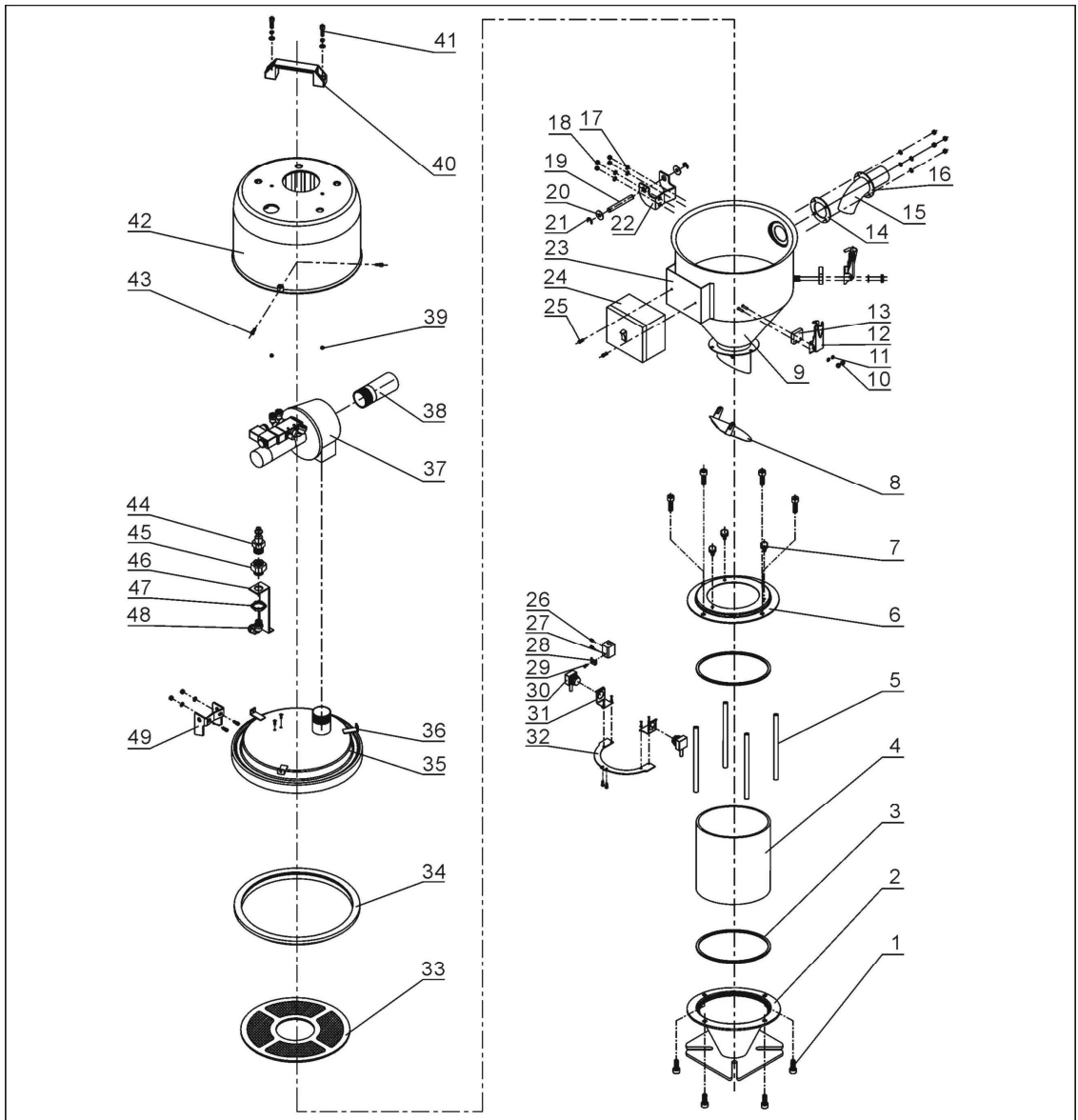

Notes: Please refer to material list 2.2.22 for specific explanation of the Arabic numbers in parts drawing.

Picture 2-12: Parts (SHR-12U-ES)

2.2.22 Parts List (SHR-12U-ES)

Table 2-11: Parts List (SHR-12U-ES)

No.	Name	Part No.	No.	Name	Part No.
1	Inner hexagon cylinder head screw M6×15	YW61061600300	26	Set screw M4×5	YW68004500000
2	Down flange of glass pipe	BL21000610710	27	Photosensor cable pressure block	BL90001000120
3	Glass pipe fastener	YR10001200100	28	Photosensor cable pressure block	YW31616200000
4	Glass pipe Φ170×Φ160×170	YW70171700000	29	Cross recess pan head screw M4×10	YW63041000000
5	Flange connection shaft	BH10101600210	30	Photosensor FOTEK T18-3MN-PE	YE15143900000
6	Up flange of glass pipe	BW32001200110	31	Photosensor mounting plate	-
7	Plastic handle screw M6×15	YW69621600000	32	Photosensor fixing plate	-
8	Non-return flap	-	33	Filter screen	BL21001200320
9	Material storage tank	-	34	Hopper fastener	YR10000600200
10	Locknut M4×0.7	YW64040700100	35	Hopper cover	-
11	Flat gasket 4	YW66040800000	36	Motor fixing base	BL21001501320
12	Snap hook	YW02003000400	37	Diaphragm valve 1.5"	-
13	Snap hook pad	YR40000600800	38	Air suction pipe	-
14	Material inlet pipe fastener	YR10061200000	39	Locknut M6	YW64000600200
15	Material inlet pipe	-	40	Aluminum square handle L120	BW20012000040
16	Material inlet pipe fixing plate	-	41	Inner hexagon cylinder head screw M6×20	YW61062000300
17	Flat gasket 5	YW66051000100	42	Motor cover	BR40036000310
18	Locknut M5	YW64000500000	43	Cross recess pan head screw M5×15	YW62051500000
19	Hinge pin	BH10006003110	44	Quick connector 3" ×1/4PT	YW80031400000
20	Flat gasket 8×22	YW66082200100	45	Connection copper head	BH12002400010
21	E rings 6	YW69896800000	46	Air pipe connector fixing block	-
22	Down hinge	BL32000600140	47	Connecting nut	BH12003600410
23	Control box base	-	48	Quick connector APLB8-1/4PT	YW80081400100
24	Control box	BH90615000010	49	Up hinge	BL32000600240
25	Cross recess pan head screw M4×6	YW63040600000			

* means possible broken parts. ** means easy broken part. and spare backup is suggested. Please confirm the version of manual before placing the purchase order to make sure that the item number of the spare part is in accordance with the real object.

2.2.23 Parts Drawing (SHR-24U-ES)

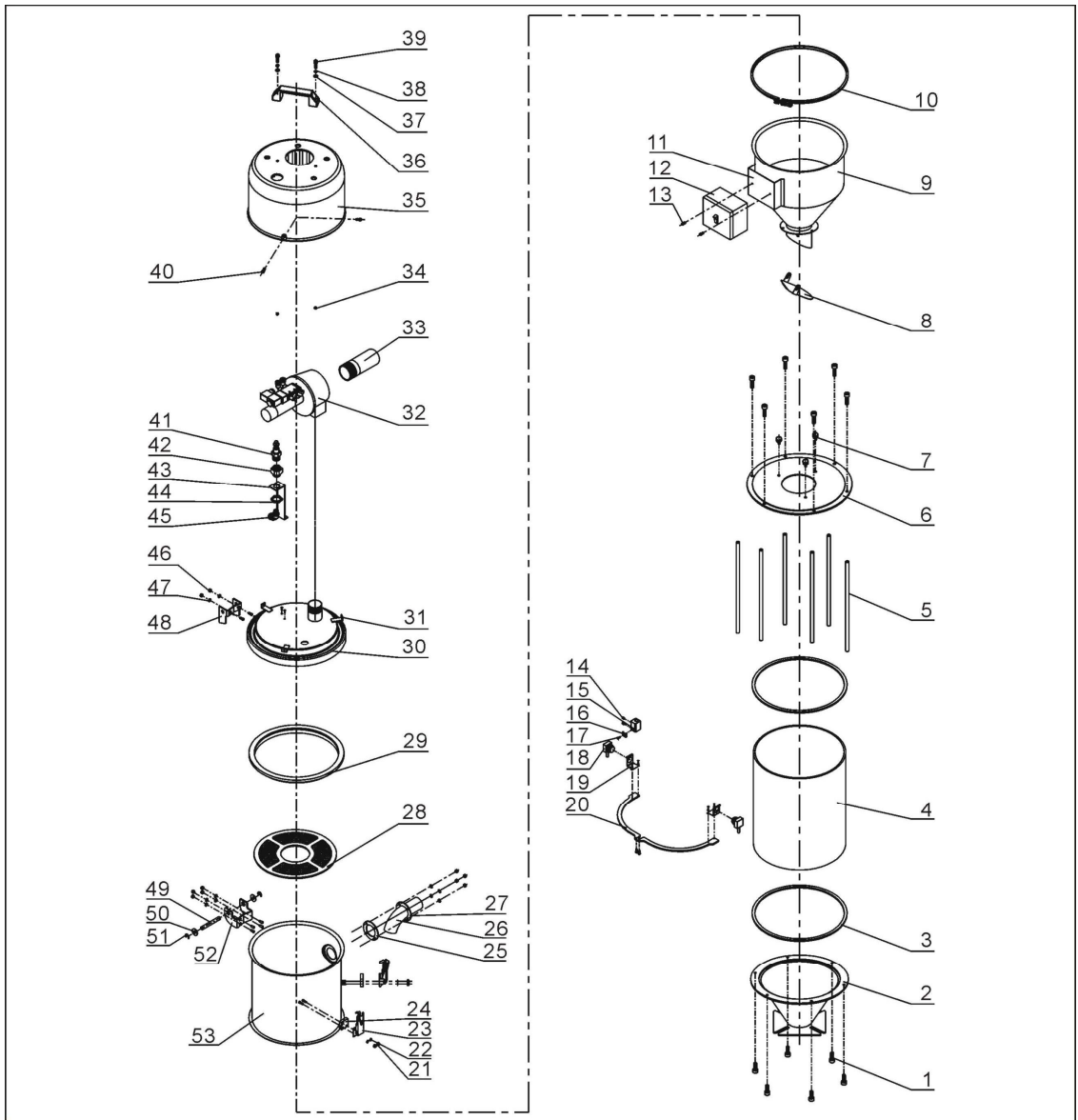

Notes: Please refer to material list 2.2.24 for specific explanation of the Arabic numbers in parts drawing.

Picture 2-13: Parts (SHR-24U-ES)

2.2.24 Parts List (SHR-24U-ES)

Table 2-12: Parts List (SHR-24U-ES)

No.	Name	Part No.	No.	Name	Part No.
1	Inner hexagon cylinder head screw M6×15	YW61061600300	28	Filter screen	BL21001200320
2	Down flange of glass pipe	-	29	Hopper fastener	YR10000600200
3	Glass pipe fastener	YR10001200100	30	Hopper cover	-
4	Glass pipe Φ280×Φ270×340	YW70282700000	31	Motor cover fixing base	BL21001501320
5	Flange connection shaft	BH10103300040	32	Diaphragm valve 2"	-
6	Up flange of glass pipe	-	33	Air suction pipe	-
7	Plastic handle screw M6×15	YW69621600000	34	Locknut M6	YW64000600200
8	Non-return flap	-	35	Motor cover	BR40036000310
9	Material storage tank	-	36	Aluminum square handle L120	BW20012000040
10	Pipe clamp	-	37	Flat gasket 6	YW66061300000
11	Control box base	-	38	Spring gasket 6	YW65006000000
12	Control box	BH90615000010	39	Inner hexagon cylinder head screw M6×20	YW61062000300
13	Cross recess pan head screw M4×6	YW63040600000	40	Cross recess pan head screw M5×15	YW62051500000
14	Set screw M4×5	YW68004500000	41	Quick connector 3" ×1/4PT	YW80031400000
15	Photosensor fixing base	BL90001000120	42	Connection copper head	BH12002400010
16	Photosensor cable pressure block	YW31616200000	43	Air pipe connector fixing block	-
17	Cross recess pan head screw M4×10	YW63041000000	44	Connecting nut	BH12003600410
18	Photosensor	YE15143900000	45	Quick connector	YW80081400100
19	Photosensor mounting plate	-	46	Locknut M5	YW64000500000
20	Photosensor fixing plate	-	47	Flat gasket 5	YW66051000100
21	Locknut M4×0.7	YW64040700100	48	Up hinge	BL32000600240
22	Flat gasket 4	YW66040800000	49	Hinge pin	BH10006003110
23	Snap hook	YW02003000400	50	Flat gasket 8×22	YW66082200100
24	Pad	YR40000600800	51	E rings 8	YW69896800000
25	Material inlet pipe fastener	YR10243600000	52	Down hinge	BL32000600140
26	Material inlet pipe	-	53	Enlarged material tank	-
27	Material inlet pipe fixing plate	-			

* means possible broken parts. ** means easy broken part. and spare backup is suggested. Please confirm the version of manual before placing the purchase order to make sure that the item number of the spare part is in accordance with the real object.