

## 2.2 Spare Parts List

### 2.2.1 Main Structure

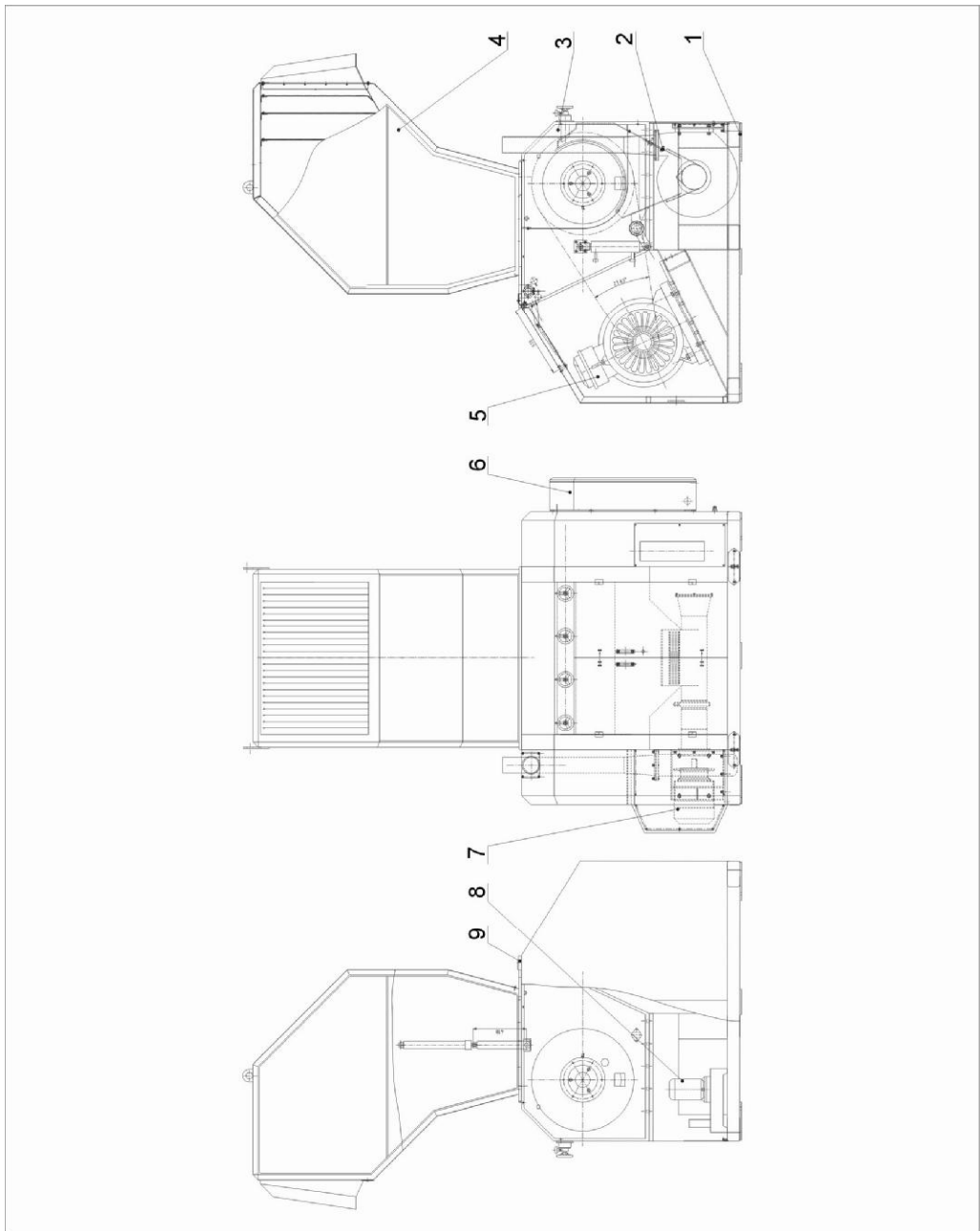

Parts name:

- |                      |                            |                                 |
|----------------------|----------------------------|---------------------------------|
| 1. Machine assembly  | 2. Screen bracket assembly | 3. Granulating chamber assembly |
| 4. Feed box assembly | 5. Drive unit              | 6. Power distribution unit      |
| 7. Convey unit       | 8. Hydraulic pressure unit | 9. Cover unit                   |

Picture 2-6: Main Structure

## 2.2.2 Cutting Chamber and Knives Rest

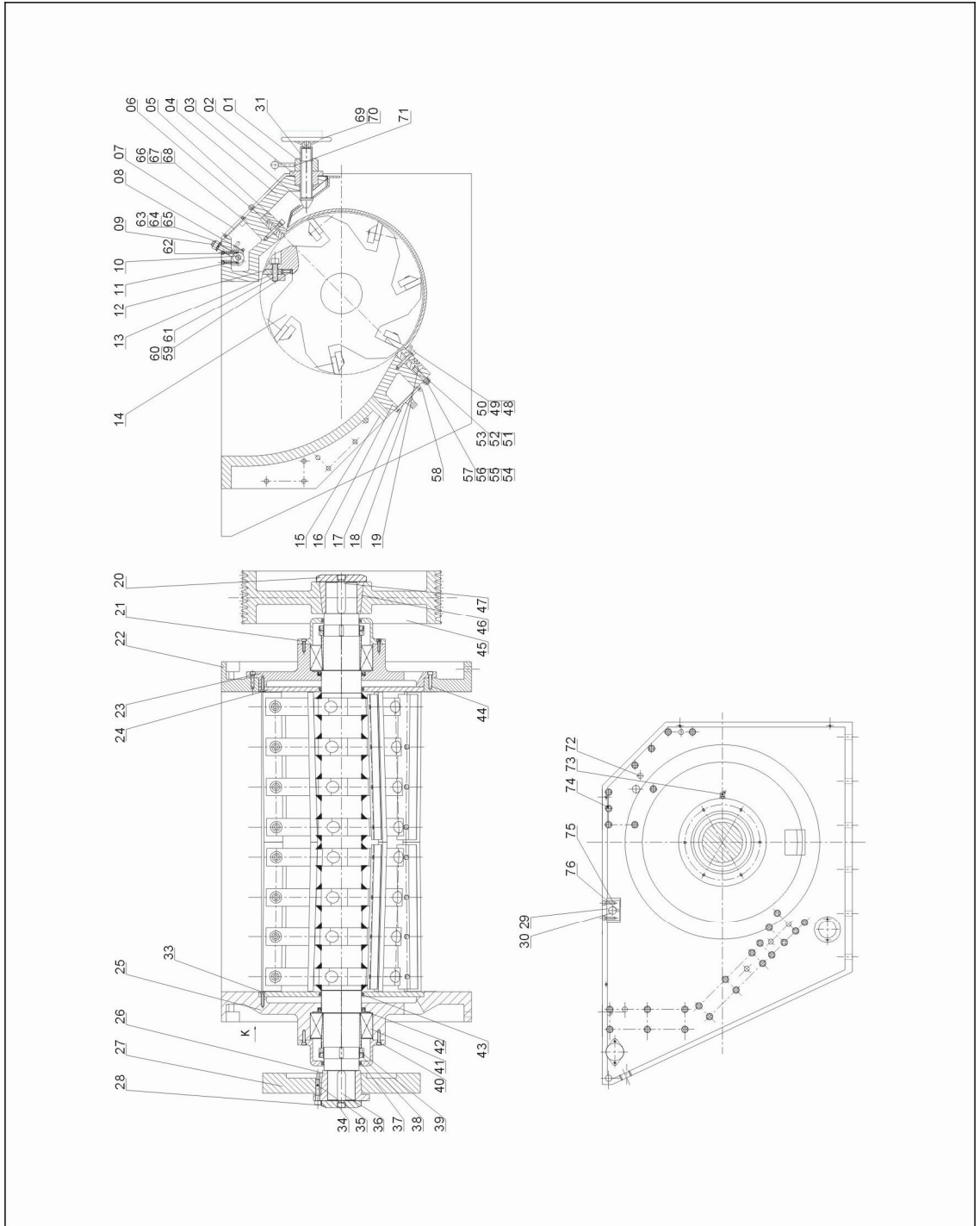

Note: Please refer to 2.2.4 material list about the parts code.

Picture 2-7: Cutting Chamber and Knives Rest

## 2.2.3 Cutting Chamber and Blade Shaft List

Table 2-1: Cutting Chamber and Blade Shaft List

No.	Name	P/N	
		SG-7090	SG-70120
1	Trapezia lockup screen	BH10701220040	BH10701220040
2	Trapezia nut	BH10701230040	BH10701230040
3	Screen bracket fixed screw	BH10701240010	BH10701240010
4	Front block	-	YW30701205100 YW30701205200
5	Fixed blade press plate 1	-	BH10701206010
6	Fixed blade	-	YW43701200600
7	Front block cover board	-	-
8	Sensor bracket	-	-
9	Seed box lockup bolt	BH10701202710	BH10701202710
10	Lockup bolt pin	BH10701201010	BH10701201010
11	Lockup bolt base	BH10701201110	BH10701201110
12	Rotating blade	YW43701201200	YW43701201200
13	Rotating blade press plate	BH10701213010	BH10701213010
14	Blade rest shaft	-	BH10701201410
15	Block top block	-	YW30701201500
16	Back bottom block	-	YW30701201600
17	Water tank cover	-	-
18	Water tank shim	BR90701201820	BR90701201820
19	Fixed blade press plate 2	BH10701201910	BH10701201910
20	Belt pulley taper sleeve baffle plate	BH10701202010	BH10701202010
21	Bearing cover	YW30701202100	YW30701202100
22	Right block	YW30701202200	YW30701202200
23	Left bearing block	YW30701202400	YW30701202400
24	Left and right material baffle plate	BH10701202310	BH10701202310
25	Left right block	YW30701202500	YW30701202500
26	Flywheel taper sleeve	YW30505012500	YW30505012500
27	Flywheel	YW30800800000	YW30800800000
28	Flywheel taper sleeve baffle plate	BH10701202610	BH10701202610
29	Pushing down plate pin base	BH10701211010	BH10701211010
30	Pushing down plate pin	BH10701210010-	BH10701210010-

No.	Name	P/N	
		SG-7090	SG-70120
31	Safety sleeve	BL55701202140	BL55701202140
32	-	-	-
33	Countersunk head screw with notching M12×30	YW61123000100	YW61123000100
34	Inner hexagonal screw column M20×50	YW61205000000	YW61205000000
35	Inner hexagonal screw column M16×70	YW61167000000	YW61167000000
36	Flat key with single round end C32×118	YW10321180000	YW10321180000
37	Felt seal 140(160)×12	YR80141200000	YR80141200000
38	Small circular nut M145×2	YW64145200000	YW64145200000
39	Anti-loosing washer for circular nut 145	YW65014500000	YW65014500000
40	Inner hexagonal screw column M10×40	YW61104000000	YW61104000000
41	Self-aligning roller bearing 24 130CCK30/W33	YW11241303000	YW11241303000
42	Axial lip sealing ring with inner framework	YR20161901500	YR20161901500
43	Felt seal 160(180)×12	YR80161200000	YR80161200000
44	Inner hexagonal screw column M12×45	YW61124500000	YW61124500000
45	Belt pulley taper sleeve	YW30353508000	YW30353508000
46	Belt pulley	YW30250800000	YW30250800000
47	Flat key with single round end C32×126	YW10321260000	YW10321260000
48	Inner hexagonal screw column M12×80	YW61128000000	YW61128000000
49	Flat washer 12	YW66123200100	YW66123200100
50	Spring gasket 12	YW65012000000	YW65012000000
51	Inner hexagonal screw column M10×85	YW61108000000	YW61108000000
52	Flat washer 10	YW66103200000-	YW66103200000
53	Spring gasket 10	YW65010000100	YW65010000100
54	Inner hexagon socket set screw with flat point M16×90	YW61168500000	YW61168500000
55	Flat washer 16	YW66164000000	YW66164000000
56	Spring gasket 16	YW65016300000	YW65016300000
57	Hexagon nut M16	YW64001600000	YW64001600000
58	Inner hexagonal screw column M10×40	YW61104000000	YW61104000000
59	Inner hexagonal screw column M10×60	YW61106500000	YW61106500000
60	Hexagon nut M10	YW64001000100	YW64001000100
61	Inner hexagonal screw column M20×75	YW61207500000	YW61207500000
62	Inner hexagonal screw column M8×50	YW61085000000	YW61085000000
63	Hexagon nut M20	YW64200200000	YW64200200000

No.	Name	P/N	
		SG-7090	SG-70120
64	Flat washer M20	YW66201200000	YW66201200000
65	Spring gasket M20	YW65205200000	YW65205200000
66	Inner hexagonal screw column M6×15	YW61061600200	YW61061600200-
67	Flat washer M6	YW66061800000	YW66061800000
68	Spring gasket M6	YW65006000100	YW65006000100
69	Handwheel 18×200	YW30201800000	YW30201800000
70	Flat key with single round end C5×18	YW10051800000	YW10051800000
71	Handle (handle with ball end) M12×100	YW00121400000-	YW00121400000
72	Column pin 20×80	YW10208000000	YW10208000000
73	Pressure filling oil cup with connector type 45°M10×1	YW04010100000	YW04010100000
74	Inner hexagon screw column M16×70	YW61167000000	YW61167000000-
75	Inner hexagon screw column M10×35	YW61103500000	YW61103500000
76	Inner hexagon socket set screw with flat point M8×15	YW68082000000	YW68082000000
77	Small circular screw M160×3	YW64160300000	YW64160300000

\* means possible broken parts.

\*\* means easy broken part. and spare backup is suggested.

Please confirm the version of manual before placing the purchase order to guarantee that the item number of the spare part is in accordance with the real object.

## 2.2.4 Transmission Parts

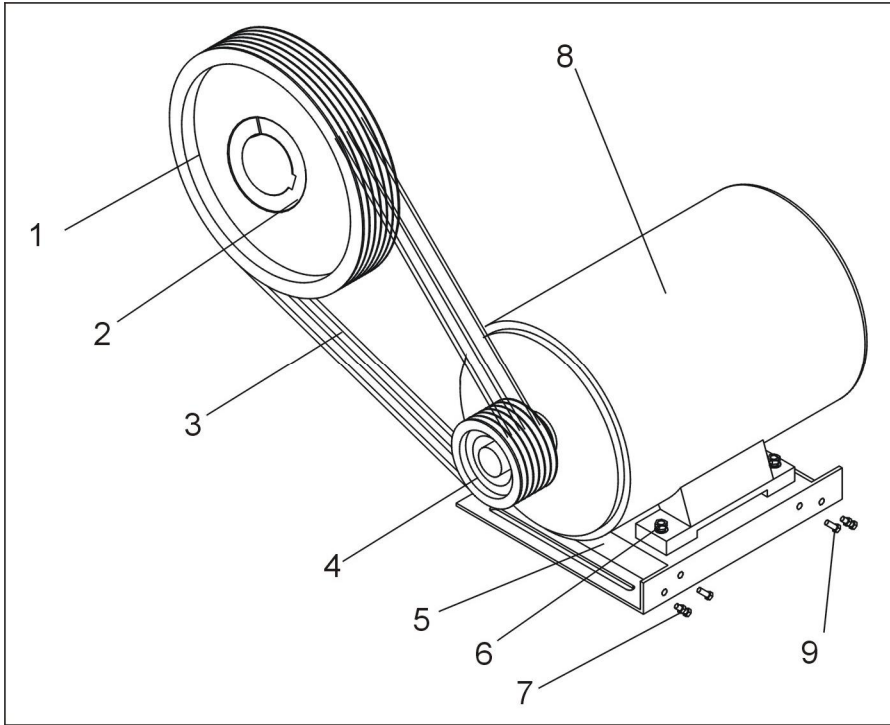

Picture 2-8: Transmission Parts

## 2.2.5 Parts List for Transmission Parts

Table 2-2: Parts List for Transmission Parts

No.	Name	Quantity
1	Big belt pulley	1
2	Lockup cover	1
3	V belt (SPC)	8
4	Small belt pulley	1
5	Motor base	1
6	Motor fixing screw	4
7	Adjusting nut	2
8	Motor	1
9	Adjusting screw	2

## 2.2.6 Screen Bracket

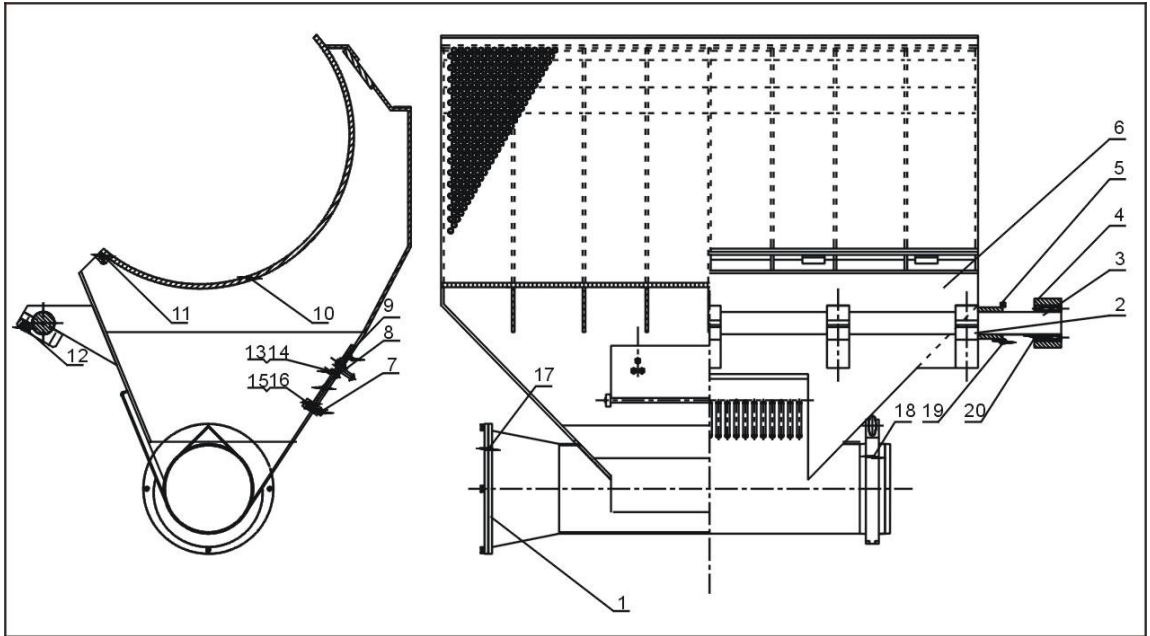

Picture 2-9: Screen Bracket

## 2.2.7 Parts List for Screen Bracket

Table 2-3: Parts List for Screen Bracket

No.	Name	Quantity
1	Press plate	2
2	Screen bracket axial base	5
3	Rotating shaft for screen bracket	1
4	Rotating arm for screen bracket	1
5	Rotating shaft bearing for screen bracket	2
6	Shell for screen bracket	1
7	Pin base for cover board	2
8	Cover board	1
9	Handle pothook	2
10	Screen	1
11	Fixed plate for screen	1
12	Inner hexagon screw column M8×45	20
13	Cross recessed head machine screw M5×15	8
14	Hexagon nut M5	6
15	Hexagon nut M10	2
16	Flat washer 10	2
17	Screen with 3 meshes	1
18	8" Food degree prep connector	1
19	Inner hexagon screw M6×20	4
20	Expansion pipe	1



## 2.2.8 Blower

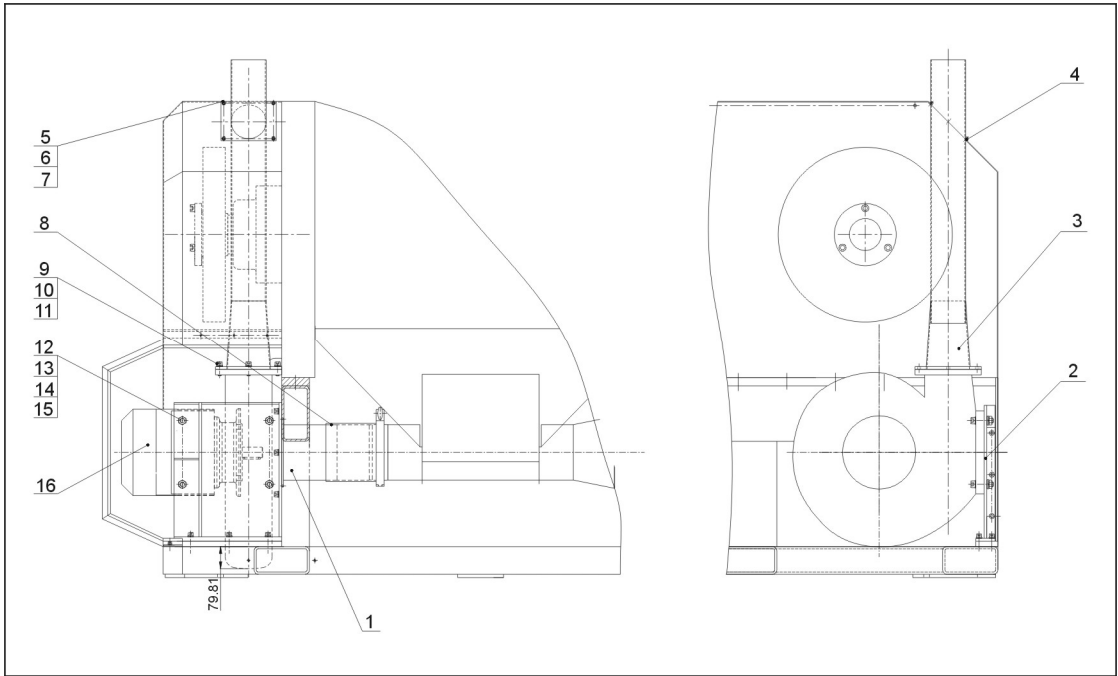

Note: Please refer to 2.2.11 material list about the parts code.

Picture 2-10: Blower

## 2.2.9 Parts List for Blower

Table 2-4: Parts List for Blower

No.	Name	Quantity
1	Pipe connector for blower air-inlet	1
2	Conveying blower base	1
3	Pipe connector for blower air outlet	1
4	Cover board for blower air outlet	1
5	Inner hexagon screw column M8×20	4
6	Flat washer 8	4
7	Spring gasket 8	4
8	8" Steel-wired plastic pipe	0.5m
9	Inner hexagon screw column M12×30	12
10	Flat washer 12	16
11	Spring gasket 12	12
12	Inner hexagon screw column M16×70	4
13	Flat washer 16	8
14	Spring gasket 16	4
15	Hexagon nut M16	4
16	High-pressure blower (5.5kW)	1

### 2.2.10 Feed-in Box, Material Check Board Inlet

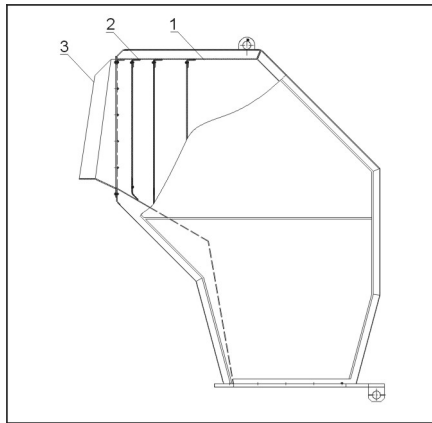

Picture 2-11: Feed-in Box, Material Check Board Inlet

### 2.2.11 Parts List for Feed Box and Material inlet of Baffle Plate

Table 2-5: Parts List for Feed Box and Material Inlet of Baffle Plate

No.	Name	Quantity
1	Feed box	1
2	Check board	4
3	Material inlet	1

## 2.2.12 Cyclone and Dust Remove Device

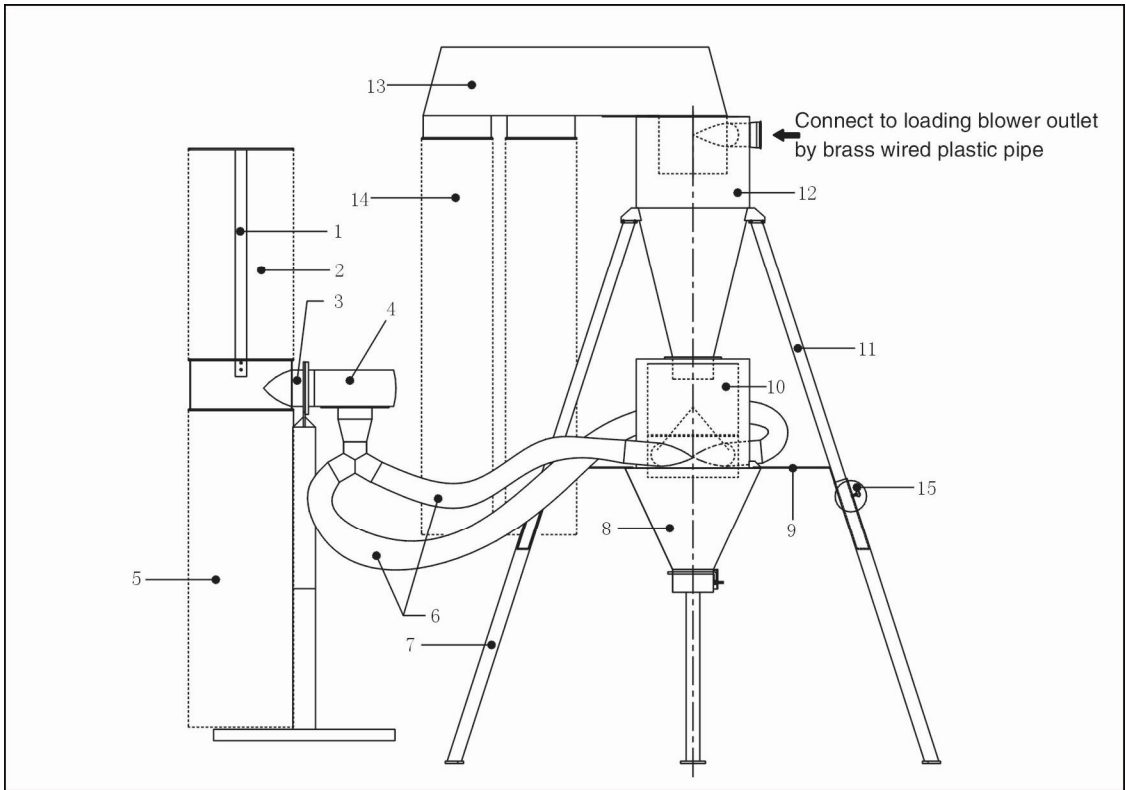

Picture 2-12: Cyclone and Dust Remove Device

## 2.2.13 Parts List of Cyclone and Dedusting Device

Table 2-6: Parts List of Cyclone and Dedusting Device

No.	Name	Quantity
1	Cloth bag support 1	1
2	Dust collective bag3(gauze 450)	1
3	(6-inch)blower and cloth bag support	1
4	6-inch blower(750W)	1
5	Dust collective bag2(thick cotton fabric)	1
6	6-inch steel wired soft pipe	2
7	Cyclone separator bottom support	3
8	Dust separator and bottom hopper	1
9	Tightener	3
10	Big and small barrels of dust separator	1
11	Upper support of Cyclone separator	3
12	Mainbody of cyclone separator	1
13	Air outlet pipe of cyclone separator	1
14	Dust collective bag1(gauze450)	2
15	Upper and bottom support pins for cyclone separator	3