

## 2.2 Assembly Drawing

### 2.2.1 Assembly Drawing (STM-607W/910W)

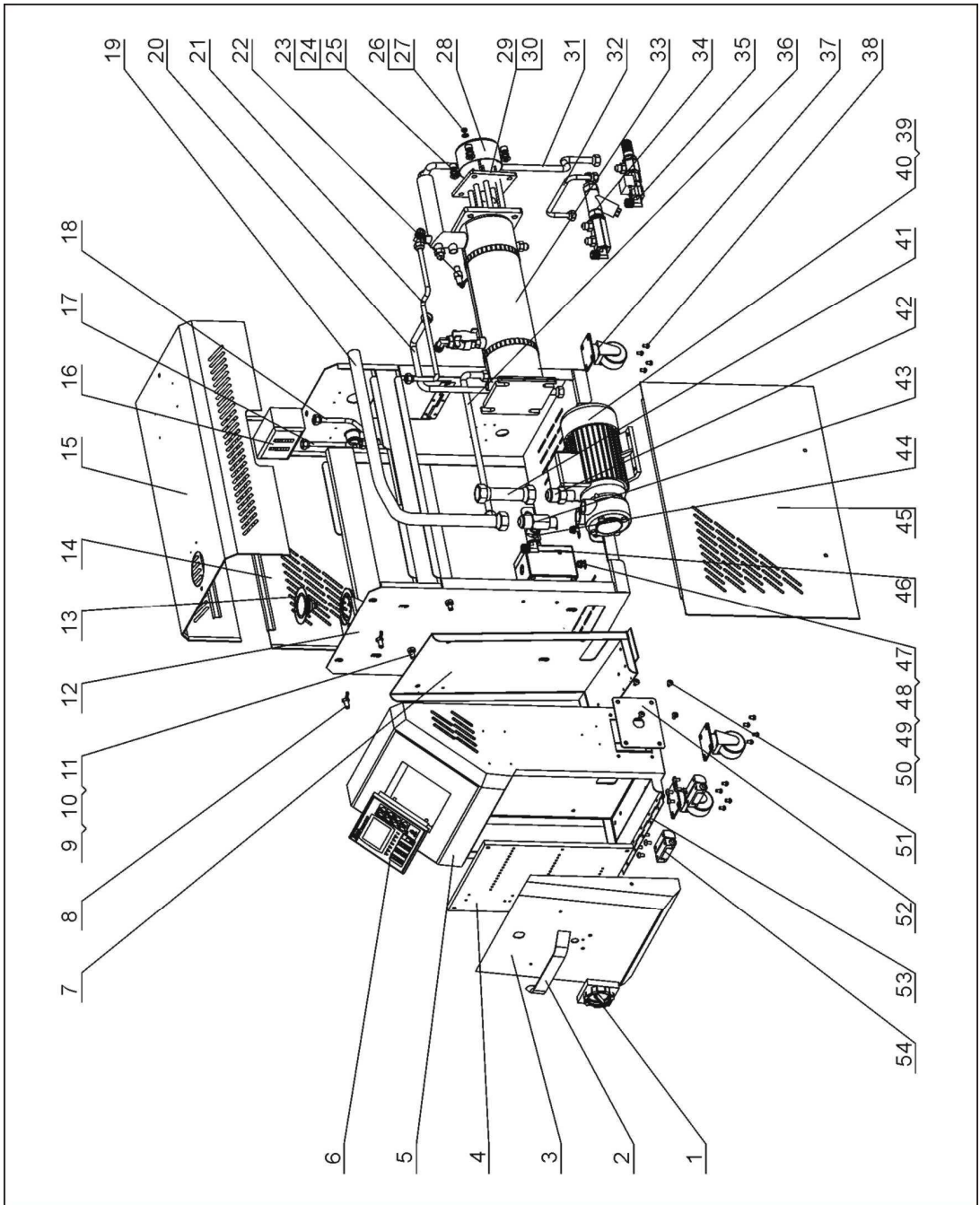

Remarks: Please refer to material list 2.2.2 for specific explanation of the Arabic numbers in parts drawing.

Picture 2-2: Assembly Drawing (STM-607W/910W)

## 2.2.2 Parts List (STM-607W/910W)

Table 2-1: Parts List (STM-607W/910W)

No.	Name	Part No.	No.	Name	Part No.
1	Main power switch	YE10323200000	28	Electric heating pipe shield	BL80091000120
2	Door plate aluminum handle 6609	YW20660900100	29	Pipe heater unit STM-910W(9kW)	BH70091000250
3	Door plate	-	30	Pipe heater unit STM-607W(6kW)	BH70060700250
4	Base plate of electric control box	-	31	Teflon pipe with joint 3/8"*50CM	YW59385000000
5	Electric control box	-	32	Chilling water by-pass pipe	-
6	HANYOUNG controller MT100-01	YE81100010000	33	Heating tank parts	-
7	Electric control box rear plate	-	34	Filling water joint parts	-
8	Butterfly srew M8×15	YW69081500000	35	Drainage joint parts	-
9	Inner hexagon screw M8×20	YW61082000200	36	Filling water pipe	-
10	Elastic gasket 8	YW65008000100	37	Caster 2"	YW03000200000
11	Flat gasket 8	YW66082200100	38	Lentil-headed screw M6×15	YW63061700000
12	Machine frame	-	39	Pump TP-55	BM20005500350
13	Pressure gauge (0~1.0MPa)	YW85001000100	40	Pump TP-75	BM20007500150
14	Side plate	-	41	Pump outlet pipe	-
15	Cover plate	-	42	Copper teflon pipe connector 3/4"H*1/2"PT	BH12030401010
16	High and low pressure switch HLP830HME	YE90832500000	43	Copper pipe connector 1/2"PT×3/4"H× 1/4"PT mesoporous	BH12030400710
17	Low pressure pipe	-	44	Stainless steel tee joint 3/8"	YW52030800000
18	High pressure pipe	-	45	Side plate	-
19	Return water pipe	-	46	EGO combination	BH90115000050
20	Hot water by-pass pipe	-	47	Elastic gasket 6	YW65006000100
21	Pressure gauge pipe	-	48	Flat gasket 6	YW66061300000
22	Thermocouple	BE90341500050	49	Hexagon nut M6	YW64000600300
23	Inner hexagon screw M10×25	YW61102500000	50	Hexagon head screw M6×25	YW60062500000
24	Elastic gasket 10	YW65010000000	51	Thick screw M5×10	YW63051000000
25	Flat gasket 10	YW66102000000	52	Linear gripper fixing plate	-
26	Screw M8	YW64000600300	53	Electric control box mounting hinge	-
27	Gasket 6	YW66061300000	54	Big hingeCL219-1	YW06219100000

\* means possible broken parts. \*\* means easy broken part. and spare backup is suggested. Please confirm the version of manual before placing the purchase order to guarantee that the item number of the spare part is in accordance with the real object.

### 2.2.3 Assembly Drawing (STM-1220W)

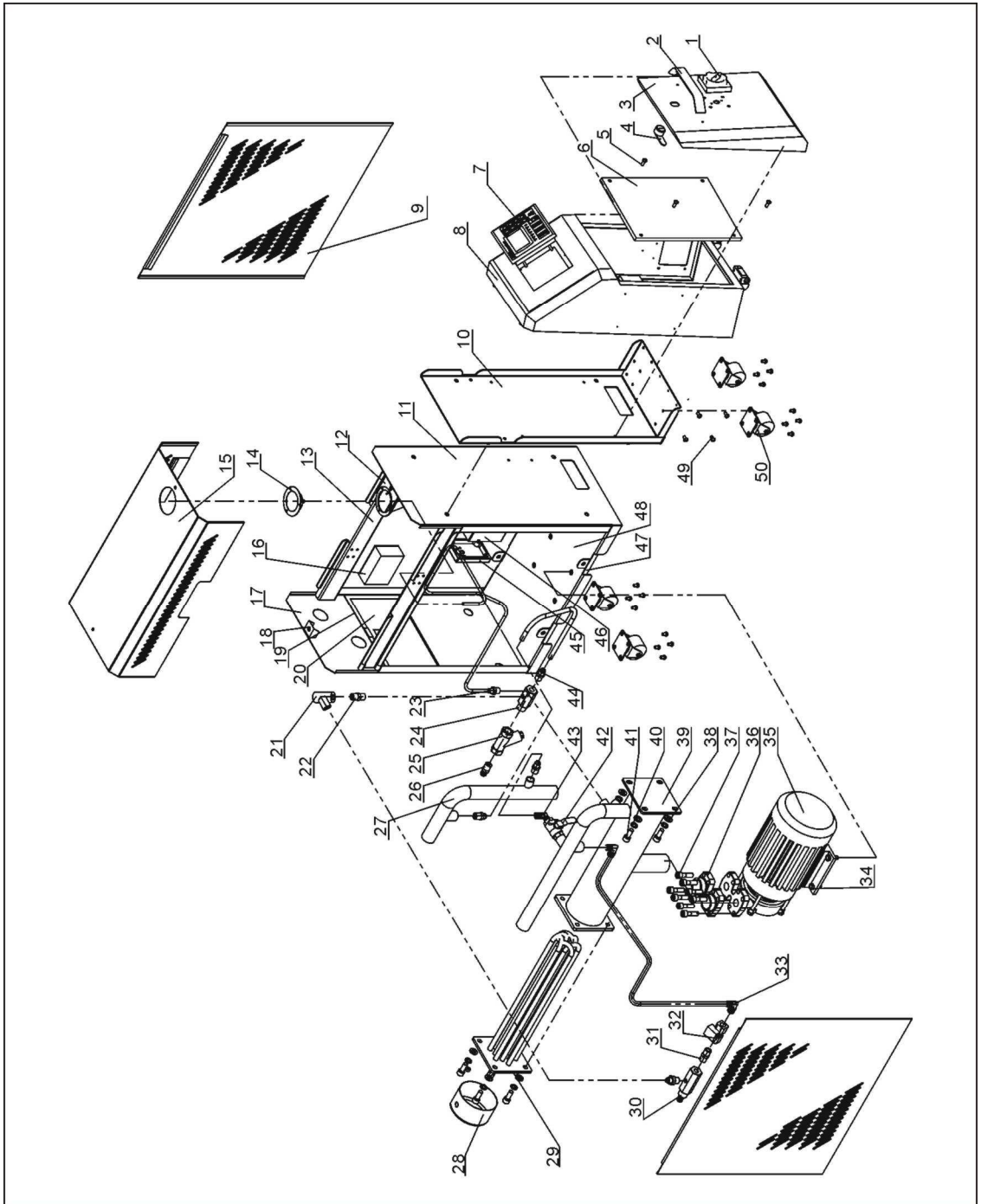

Remarks: Please refer to material list 2.2.4 for specific explanation of the Arabic numbers in parts drawing.

Picture 2-3: Assembly Drawing (STM-1220W)

## 2.2.4 Parts List (STM-1220W)

Table 2-2: Parts List (STM-1220W)

No.	Name	Part No.	No.	Name	Part No.
1	Main power switch	YE10323200000	26	Core 3/8" ×M13	BH12030801110
2	Door plate aluminum handle 6609	YW20660900100	27	Return water pipe	-
3	Door plate	-	28	Electric heating pipe shield	BL80091000120
4	Long gear lock	YW00000000100	29	Pipe heater unit	BH70122000150
5	Lentil-headed screw M6×15	YW62061500000	30	The third set of copper joint	BH12060703710
6	Base plate of electric control box	-	31	Pipe coupler 3/8"	BH12030800110
7	HANYOUNG controller	YE81100010000	32	Solenoid valve	YE32331000000
8	Electric components box	-	33	Teflon pipe connector 3/8PT×3/8H(L type)	YW04030800300
9	Side plate	-	34	Outer hexagonal screw M10×25	YW60102000100
10	Rear plate	-	35	Pump TP-150	BM20015000050
11	Clapboard	-	36	Pump flange	-
12	Pressure gauge fixing plate	-	37	Inner hexagon screw M10×25	YW61102500000
13	Pressure gauge	YW85001000100	38	Flat gasket D10	YW66102500000
14	Crossbeam	-	39	Heating tank	-
15	Cover plate	-	40	Elastic gasket D10	YW65010000000
16	High and low pressure switch	YE90832500000	41	Inner hexagon screw M10×30	YW61103000100
17	Rear plate	-	42	Copper ball core valve 1/2"	YW50010200100
18	Plate cover fixing plate	-	43	Copper teflon pipe connector 1/2H×1/2PT(L type)	YW04121200000
19	Fixing plate of rear plate mini cover	-	44	Teflon pipe connector 1/2PT×1/2H	BH12010200210
20	Rear plate mini cover	-	45	EGO protective box (up)	YR40000400300
21	Tee joint 1/4"	YW52010400000	46	EGO protective box (down)	YR40000400300
22	Pipe coupler 1/4"	BH12010400110	47	Stiffening rib 1	-
23	Copper teflon pipe connector 1/4PT×1/4H	BH12010400410	48	Base plate	-
24	The ninth set of copper joint	-	49	Lentil-headed screw M6×10	YW62061000000
25	Y type filter	YW57010200000	50	Universal castor 2"	YW03000200000

\* means possible broken parts. \*\* means easy broken part. and spare backup is suggested. Please confirm the version of manual before placing the purchase order to guarantee that the item number of the spare part is in accordance with the real object.

## 2.2.5 Assembly Drawing (STM-2440W)

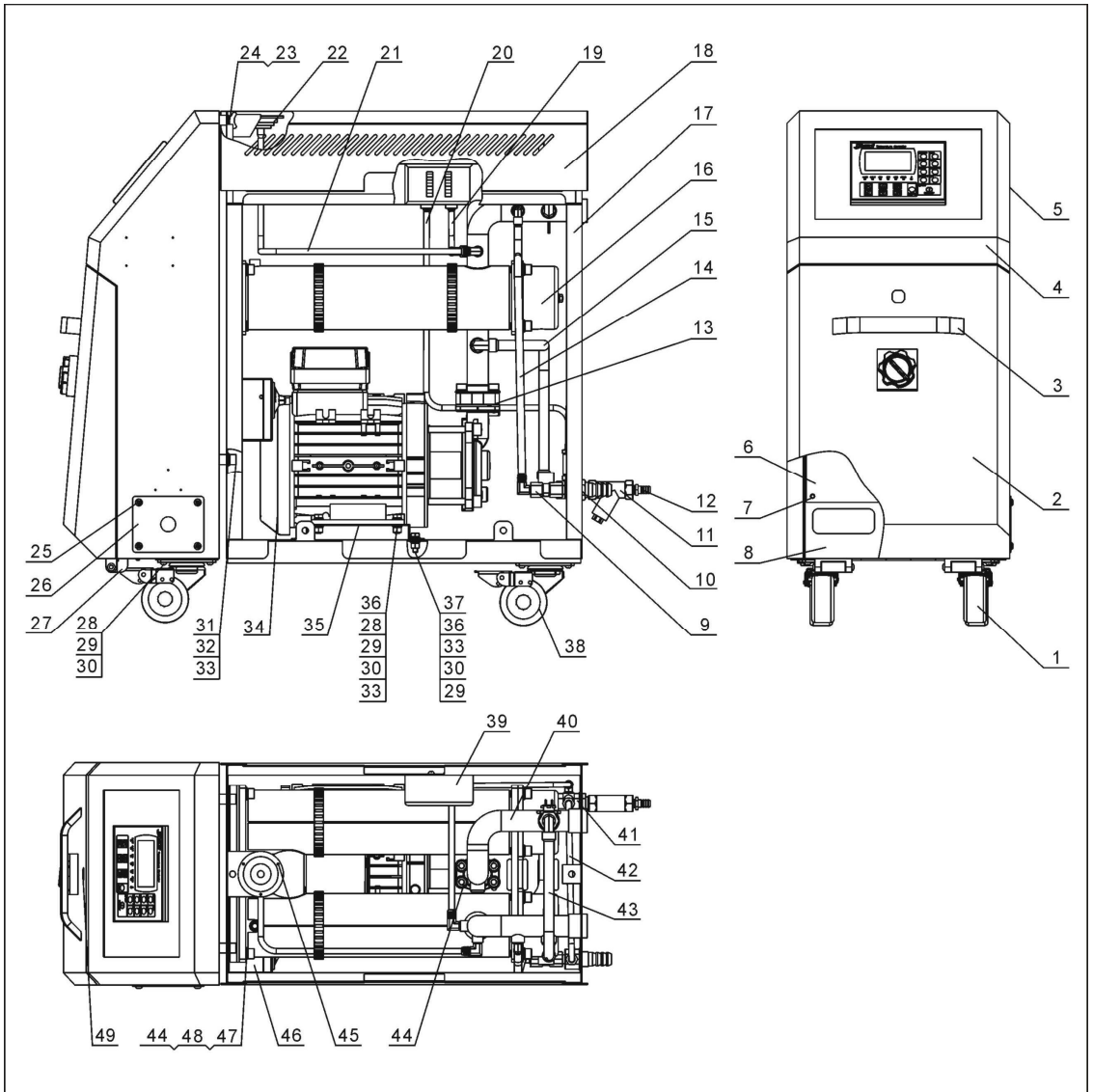

Remarks: Please refer to material list 2.2.6 for specific explanation of the Arabic numbers in parts drawing.

Picture 2-4: Assembly Drawing (STM-2440W)

## 2.2.6 Parts List (STM-2440W)

Table 2-3: Parts List (STM-2440W)

No.	Name	Part No.	No.	Name	Part No.
1	Movable castor 3"	YW03000300200	26	Line clamp fixing plate	-
2	Door plate	-	27	Big hinge CL219-1	YW60061000000
3	Door plate aluminum handle 6609	YW20660900100	28	Outer hexagon screw M6×16	YW60061600100
4	Electrical control box	-	29	Spring gasket 6mm	YW65006000100
5	Side plate	-	30	Flat gasket 6×18×1mm	YW66061800000
6	Base plate of electric control box	-	31	Inner hexagon screw M8×20	YW61082000200
7	Thick head screw M6×20	YW63062000000	32	Spring gasket 8mm	YW65008000100
8	Rear plate of electric control box	-	33	Flat gasket 8×22×1.5mm	YW66082200000
9	Water drainage pipe connector parts		34	PumpTP-280	BM20028000050
10	Copper female connector(suitable for set 1,2,3,4)	-	35	Pump base plate	-
11	Y type filtering water valve1/2"	YW57010200000	36	Hexagon nut M6	YW64000600300
12	Copper core M13×1/2PT	BH12131200010	37	Hexagon head screw M6×25	YW60062500000
13	Pump flange gasket	YR10150000000	38	Brake caster 3"	YW03000300000
14	Teflon pipe with connector 3/8"×50CM	YW59385000000	39	High and low pressure pipe HLP830HME	YE90832500000
15	Filling water pipe	-	40	Return pipe parts	-
16	Parts of heating tank	-	41	Filling pipe connector parts	-
17	Rack	-	42	Cooling water by-pass pipe	-
18	Cover plate	-	43	Hot water by-pass pipe	-
19	High pressure pipe	-	44	Inner hexagon screw M10×30	YW61103000100
20	High pressure pipe	-	45	Thick head screw M3×6	YW63030600000
21	Pressure gauge pipe	-	46	EGO assembly	BH90115000050
22	Pressure gauge (Range: 0~1.0MPa)	YW85001000100	47	Flat gasket 10.5×20×2mm	YW66102000100
23	Flat gasket 8×16×1.5mm	YW66081600000	48	Spring gasket 10mm	YW65010000000
24	Butterfly screw M8×15	YW69081500000	49	long door lock	YW00000000100
25	Lentil-headed screw M5×10	YW62051000000			

\* means possible broken parts. \*\* means easy broken part. and spare backup is suggested. Please confirm the version of manual before placing the purchase order to guarantee that the item number of the spare part is in accordance with the real object.

## 2.2.7 Assembly Drawing (STM-3650W)

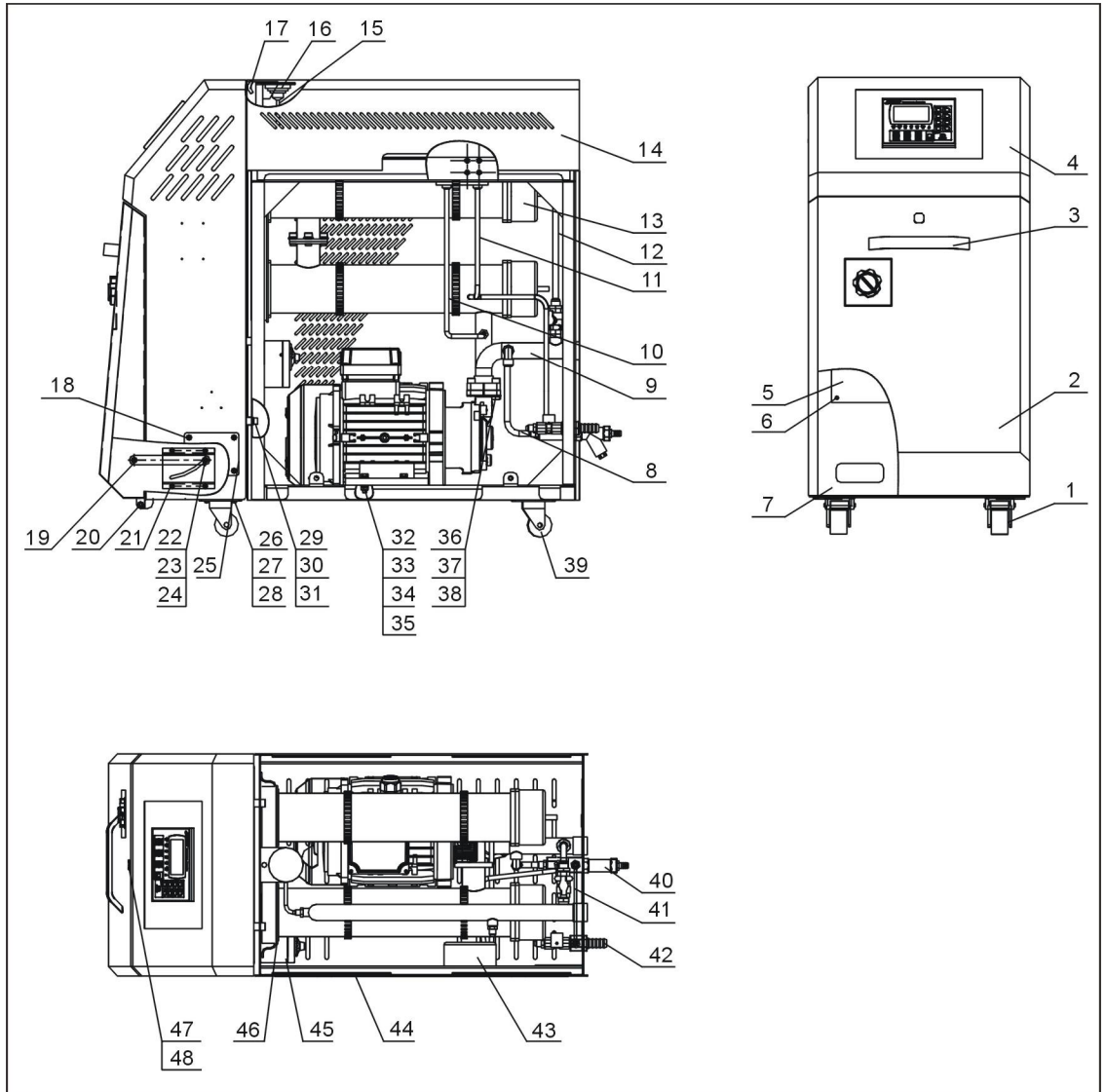

Remarks: Please refer to material list 2.2.8 for specific explanation of the Arabic numbers in parts drawing.

Picture 2-5: Assembly Drawing (STM-3650W)

## 2.2.8 Parts List (STM-3650W)

Table 2-4: Parts List (STM-3650W)

No.	Name	Part No.	No.	Name	Part No.
1	Black movable castor 3"	YW03000300200	25	Fixing plate for wire clamp	-
2	Door plate	-	26	Outer hexagon screw M6×16	YW60061600100
3	Door plate aluminum handle 6609	YW20660900100	27	Spring gasket 6	YW65006000100
4	Control box	-	28	Flat gasket 6×18×1	YW66061800000
5	Base plate of control box	-	29	Inner hexagon screw M8×20	YW61082000200
6	Thick head screw M6×20	YW63062000000	30	Flat gasket 8×22×1.5	YW66082200100
7	Rear plate of control box	-	31	Spring gasket 8	YW65008000100
8	Filling water pipe	-	32	TP-400	BM20423000050
9	Return water pipe parts	-	33	Flat gasket 8×16×1.5	YW66081600000
10	High pressure pipe	-	34	Hexagon screw M8×30	BM20015000050
11	Low pressure pipe	-	35	Hexagon nut M8	YW64080600000
12	Hot water by-pass pipe	-	36	Inner hexagon screw M8×20	YW61082000200
13	Heating tank parts	-	37	Spring gasket 8	YW65008000100
14	Cover plate	-	38	Flat gasket 8×16×1.5	YW66081600000
15	Pressure gauge pipe	-	39	Brake castor 3"	YW03000300000
16	Pressure gauge (0~10MPa range)	YW85001000100	40	Y type filter 1/2"	YW57010200000
17	Butterfly screw M8×15	YW69081500000	41	Cold water by-pass pipe	-
18	Lentil-headed screw M510	YW62051000000	42	Drainage pipe parts	-
19	Movable arm of the door plate	-	43	High and low pressure switch	YE90832500000
20	Big hinge CL219-1	YW60061000000	44	Side plate	-
21	Fixing plate of door plate	-	45	EGO assembly	BH90115000050
22	Movable pin of the door plate	-	46	Heating tank plate gasket	-
23	M5 Nut	YW64000600000	47	Long gear lock	YW00000000100
24	Flat gasket 5×13×1.0	YW66051300000	48	Baffle sheet of door lock	-

\* means possible broken parts.

\*\* means easy broken part. and spare backup is suggested.

Please confirm the version of manual before placing the purchase order to guarantee that the item number of the spare part is in accordance with the real object.



## 2.2.9 Pump

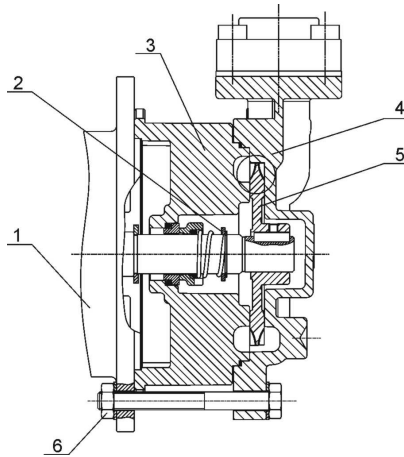

Picture 2-6: Pump

Table 2-4: Pump Parts List

No.	Name	Part No.				
		607W/607WD	910 W/910WD	1220 W	2440 W	3650 W
1	Motor	YM10055000500	YM10075000100	YM10015000000	YM10028000000	YM10040000000
2	Mechanical shaft seal *	YR80901000000	YR80901200000	YR80901600000	YR80902240000	YR80902240000
3	Bearing block	BW33005500110	BW33007500110	BW33015000110	BW33028000210	BW33028000210
4	Pump body	BW33005500210	BW33007500210	BW33015000210	BW33028000110	BW33028000110
5	Impeller	BW33055000310	BW33075000310	BW33015000310	BW33028000310	BW33028000310
6	Hexagon nut	YW64001000100	YW64001000100	YW64001000100	YW64001000100	YW64001000100

\* means possible broken parts.

\*\* means easy broken part. and spare backup is suggested.

Please confirm the version of manual before placing the purchase order to guarantee that the item number of the spare part is in accordance with the real object.