

2.3 Assembly Drawing

2.3.1 Assembly Drawing

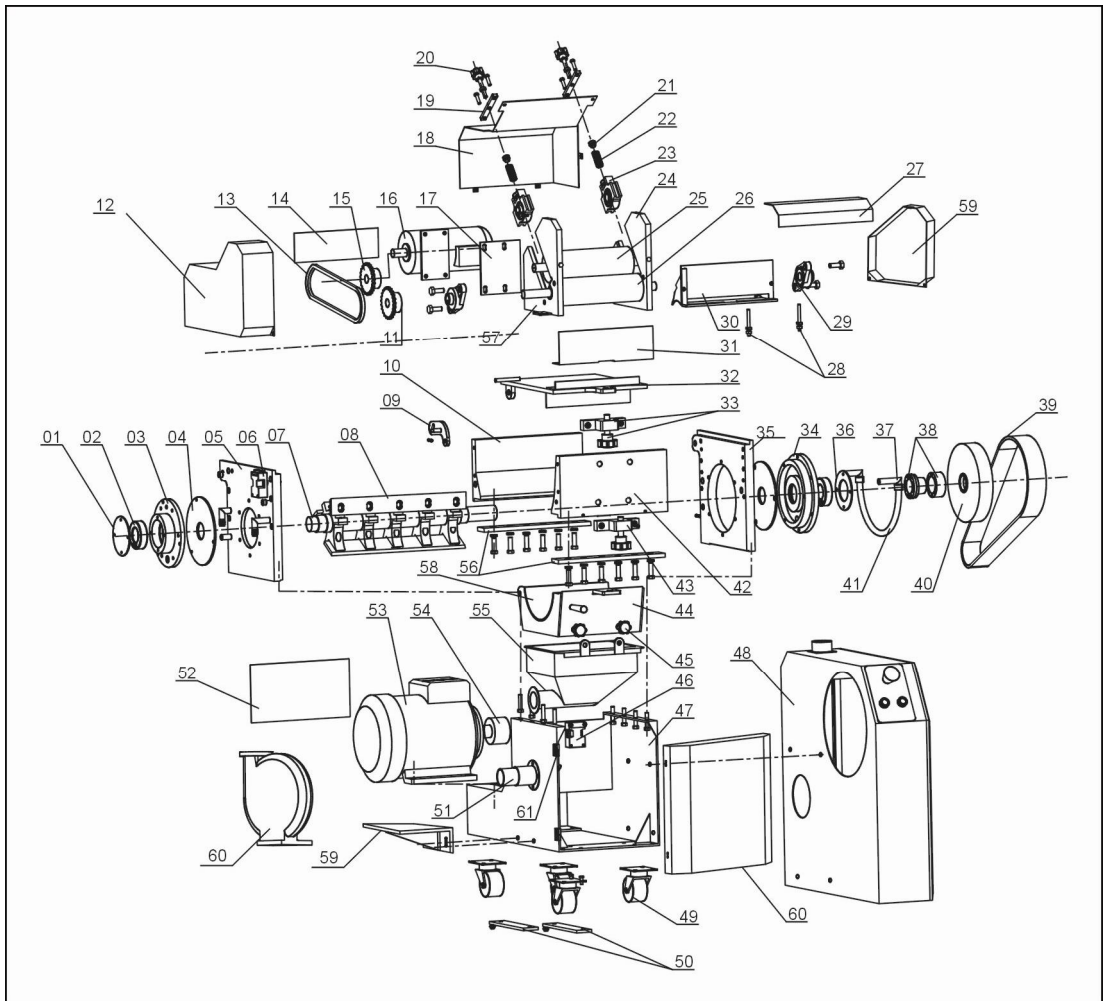

Note: Please refer to 2.3.2 material list about the parts code.

Picture 2-5: Assembly Drawing

2.3.2 Parts List

Table 2-1: Parts List

No.	Name	Part No.	
		SGF-2628E	SGF-2642E
1	Left bearing cover	BL52292800020	BL52292800020
2	Bearing	YW11220900000	YW11220900000
3	Left bearing pedestal	BW30292801010	BW30292801010
4	Material fender	YW45290000000	YW45290000000
5	Left insert block of granulator	BW30292800410	BW30292800410
6	Safety switch	YE16147600000	YE16147600000
7	Main shaft	BH11292800010	YS24604500000
8	Rotary blade	YW41292800100	YW41294200100
9	Supporting block	BH10292800140	BH10292800140
10	Rear insert block of granulator	YW30292800900	YW30292800900
11	Sprocket wheel 1	YW30292800600	YW30292800600
12	Small motor cage	BL57292800020	BL57292800020
13	Chain	YW09081200000	YW09081200000
14	Feed throat welded pin	BL52292800020	BL52292800020
15	Sprocket wheel 2	YW30292800800	YW30292800800
16	Reducer	YM50112000000	YM50112000000
17	Installation board of small motor	-	-
18	Rear cover plate of small motor	-	-
19	Adjusting block of driven wheel	BL52292800120	BL52292800120
20	Long hexagonal screw	YR40166000000-	YR40166000000-
21	Pressure head	BH10292800240	BH10292800240
22	Compression spring*	YW01163600000	YW01163600000
23	Bearing cover	YW30292801100	YW30292801100
24	Feed throat welded right plate	-	-
25	Driven running roller	YW30292800300	YW30292800300
26	Driving running roller	BH10292800210	BH10292800210
27	Feed throat welded top plate	-	-
28	Material size adjusting pole	BH10292800010	BH10292800010
29	Bearing pedestal	YW11020500000	YW11020500000
30	Material fending component	-	-
31	Feed throat welded front plate	-	-
32	Feed throat welded bottom plate	-	-
33	Connecting block 1 and hexagonal handle	YW09001000000	YW09001000000
34	Right insert block of granulator	BW30292800210	BW30292800210
35	Right bearing pedestal	BW30292800610	BW30292800610

No.	Name	Part No.	
		SGF-2628E	SGF-2642E
36	Right bearing cover	YW30292800200	YW30292800200
37	Water supply pipe connector	BW04030800010	BW04030800010
38	Lock ring	BH13200001010	BH13200001010
39	Poly V-belt *	YR00562000000	YR00562000000
40	Big belt pulley	YW30292800000	YW30292800000
41	Cooling copper pipe	BL57292800020	BL57292800020
42	Front insert block of granulator	YW30292800100	YW30292800100
43	Connecting block 2 and hexagonal handle	YW09001000000	YW09001000000
44	Assembly of screen frame	-	-
45	Hexagonal handle	YW09100000000	YW09100000000
46	Safety switch*	YE16147600000	YE16147600000
47	General supporting frame	-	-
48	Assembly of electric cabinet	-	-
49	Truckle	YW03000300400 YW03000300200	YW03000300400 YW03000300200
50	Adjusting plate for main motor installation	-	-
51	Extraction line	-	-
52	Rear baffle plate	-	-
53	Main motor	YM10113300000	YM10135500000
54	Small belt pulley	YW30292800400	YW30292800400
55	Storage box	BL52292810020	BL52294210020
56	Static blade**	YW41292800000	YW41294200000
57	Feed throat welded right plate	-	-
58	Screen**	BL52042700020	BL52044100020
59	Right outer shell	-	-
60	Front door	-	-
61	Hinge	YW06203100400	YW06203100400

* means possible broken parts.

** means easy broken part. and spare backup is suggested.

Please confirm the version of manual before placing the purchase order to guarantee that the item number of the spare part is in accordance with the real object.

2.3.3 Cutting Chamber

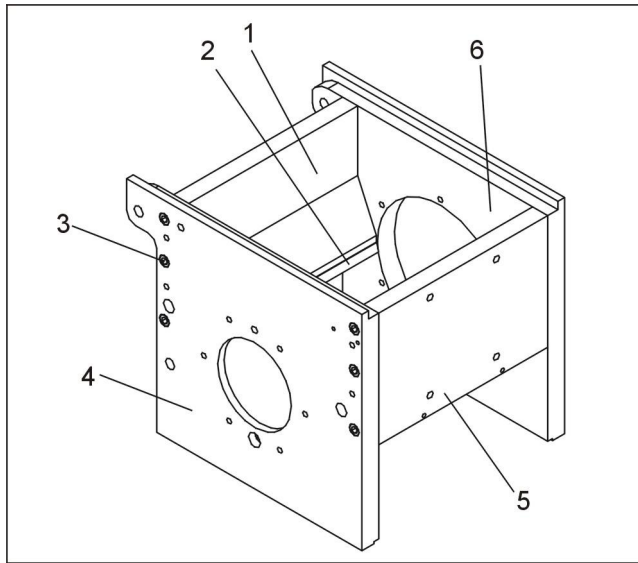

Picture 2-6: Cutting Chamber

2.3.4 Cutting Chamber Parts List

Table 2-2: Cutting Chamber Parts List

No.	Name	Quantity
1	Cutting chamber back block	1
2	Fixed blade	1
3	Inner hexagon cylindrical screw	12
4	Cutting chamber left block	1
5	Cutting chamber front block	1
6	Cutting chamber right block	1

2.3.5 Blade Rest

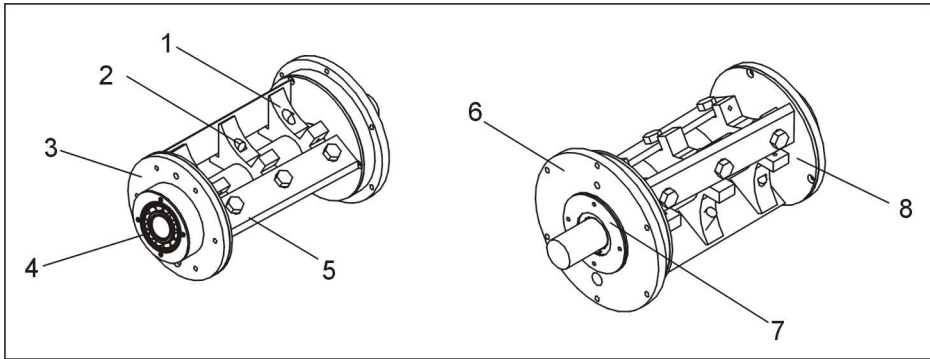

Picture 2-7: Blade Rest

2.3.6 Blade Rest Parts List

Table 2-3: Blade Rest Parts List

No.	Name	Quantity
1	Blade rest shaft	1
2	Hexagon screw bolt	9/15
3	Left bearing block	1
4	Bearing	2
5	Rotary blade	3
6	Right bearing block	1
7	Damper	2
8	Bearing cover	1

2.3.7 Transmission Parts

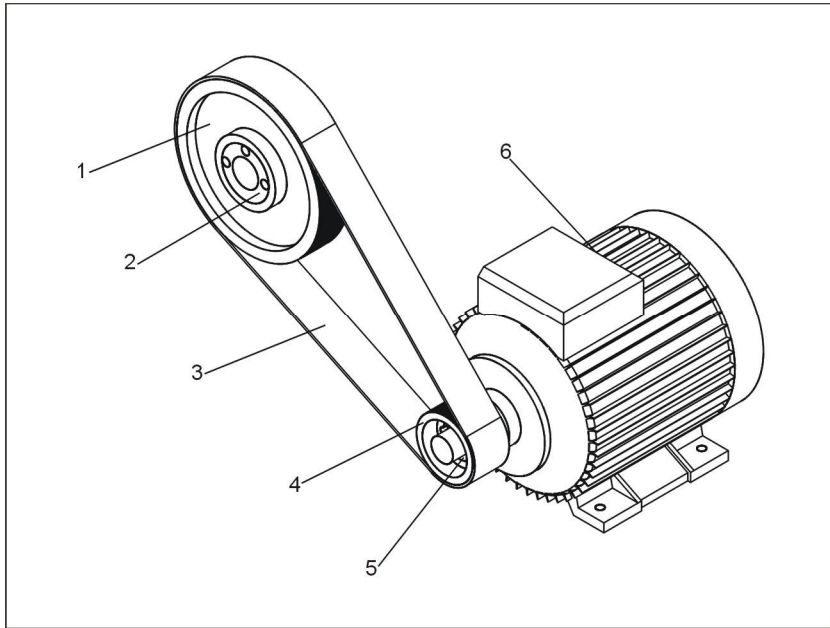

Picture 2-8: Transmission Parts

2.3.8 Transmission Parts List

Table 2-4: Transmission Parts List

No.	Name	SGF-2628E		SGF-2642E	
		Part No.	Quantity	Part No.	Quantity
1	Big belt pulley	YW30231900000	1	YW30231900000	1
2	Taper sleeve 3020-45	YW30302450000	1	YW30302450000	1
3	Poly V-belt 56"	YR00562000000	1	YR00562000000	1
4	Small belt pulley	YW30209800000	1	YW30209800000	1
5	Taper sleeve 1610-38	YW30163800000	1	YW30163800000	1
6	Main motor	YM10113300000	1	YM10135500000	1

2.3.9 Screen and Its Frame

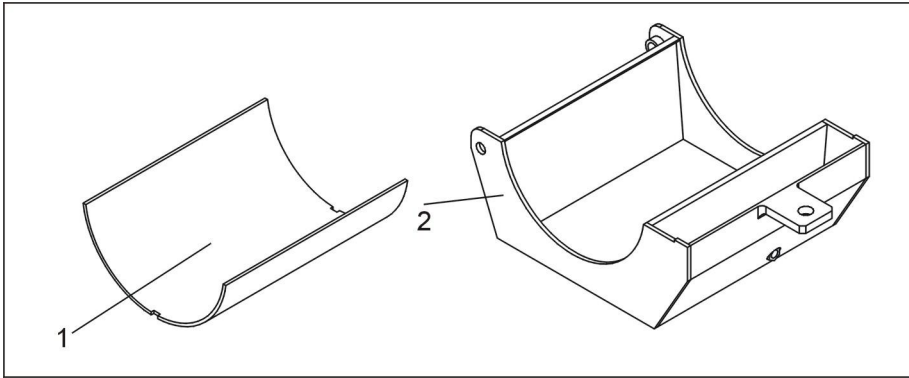

Picture 2-9: Screen and Its Frame

2.3.10 Screen and Its Frame Parts List

Table 2-5: Screen and Its Frame Parts List

No.	Name	SGF-2628E		SGF-2642E	
		Part No.	Quantity	Part No.	Quantity
1	Screen	BL52292800820	1	BL52294200820	1
2	Assembly of screen bracket	-	1	-	1

2.3.11 Storage Box

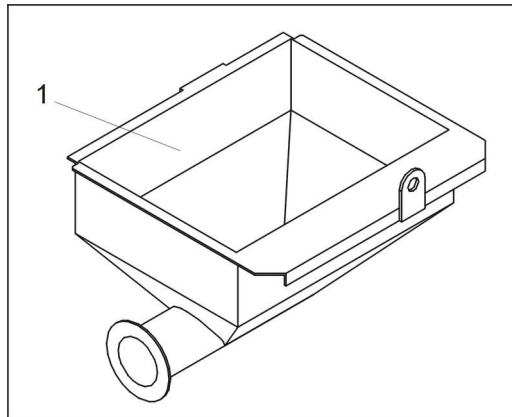

Picture 2-10: Storage Box

2.3.12 Storage Box Parts List

Table 2-6: Storage Box Parts List

No.	Name	SGF-2628E		SGF-2642E	
		Part No.	Quantity	Part No.	Quantity
1	Storage box	-	1	-	1

2.3.13 Main Supporting Frame

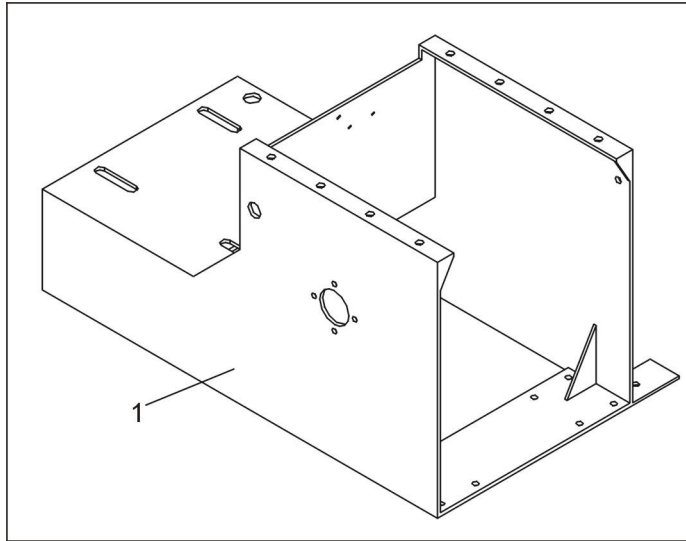

Picture 2-11: Main Supporting Frame

2.3.14 Main Supporting Frame Parts List

Table 2-7: Main Supporting Frame Parts List

No.	Name	SGF-2628E		SGF-2642E	
		Part No.	Quantity	Part No.	Quantity
1	Main supporting frame	-	1	-	1

2.3.15 Rolling Device

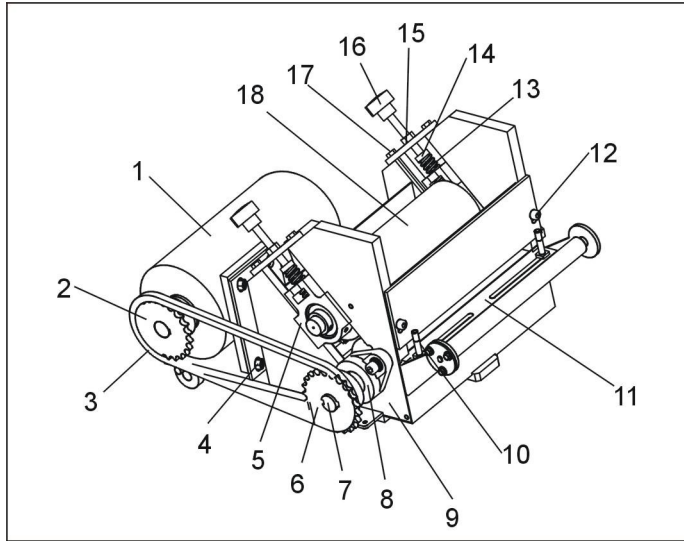

Picture 2-12: Rolling Device

2.3.16 Rolling Device Parts List

Table 2-8: Rolling Device Parts List

No.	Name	SGF-2628E		SGF-2642E	
		Part No.	Quantity	Part No.	Quantity
1	Gear box	YM5011200000	1	YM5011200000	1
2	Sprocket wheel 1	YW30292800600	1	YW30292800600	1
3	Chain	YW09081200000	1	YW09081200000	1
4	Hex nut	YW64000800100	4	YW64000800100	4
5	Bearing	YW11020500100	2	YW11020500100	2
6	Sprocket wheel 2	YW30292800800	1	YW30292800800	1
7	Driving running roller	BH10292803010	1	BH10294020010	1
8	Bearing	YW11020500000	2	YW11020500000	2
9	Welding feeding port	-	1	-	1
10	Material size adjusting pole	BH10292800040	2	BH10292800040	2
11	Material fending component	-	1	-	1
12	Inner hexagon cylindrical	YW61082000200	2	YW61082000200	2
13	Spring	YW01163600000	2	YW01163600000	2
14	Pressure head	BH10292800240	2	BH10292800240	2
15	Adjusting block of driven	BL52292800140	2	BL52292800140	2
16	Long star screw	YW09107000000	2	YW09107000000	2
17	Hexagon screw bolt	YW60083000200	4	YW60083000200	4
18	Driven running roller	YW30292800300	1	YW30292800500	1