

## 2.2 Assembly Drawing

### 2.2.1 Structure Chart (STC-607-3W)

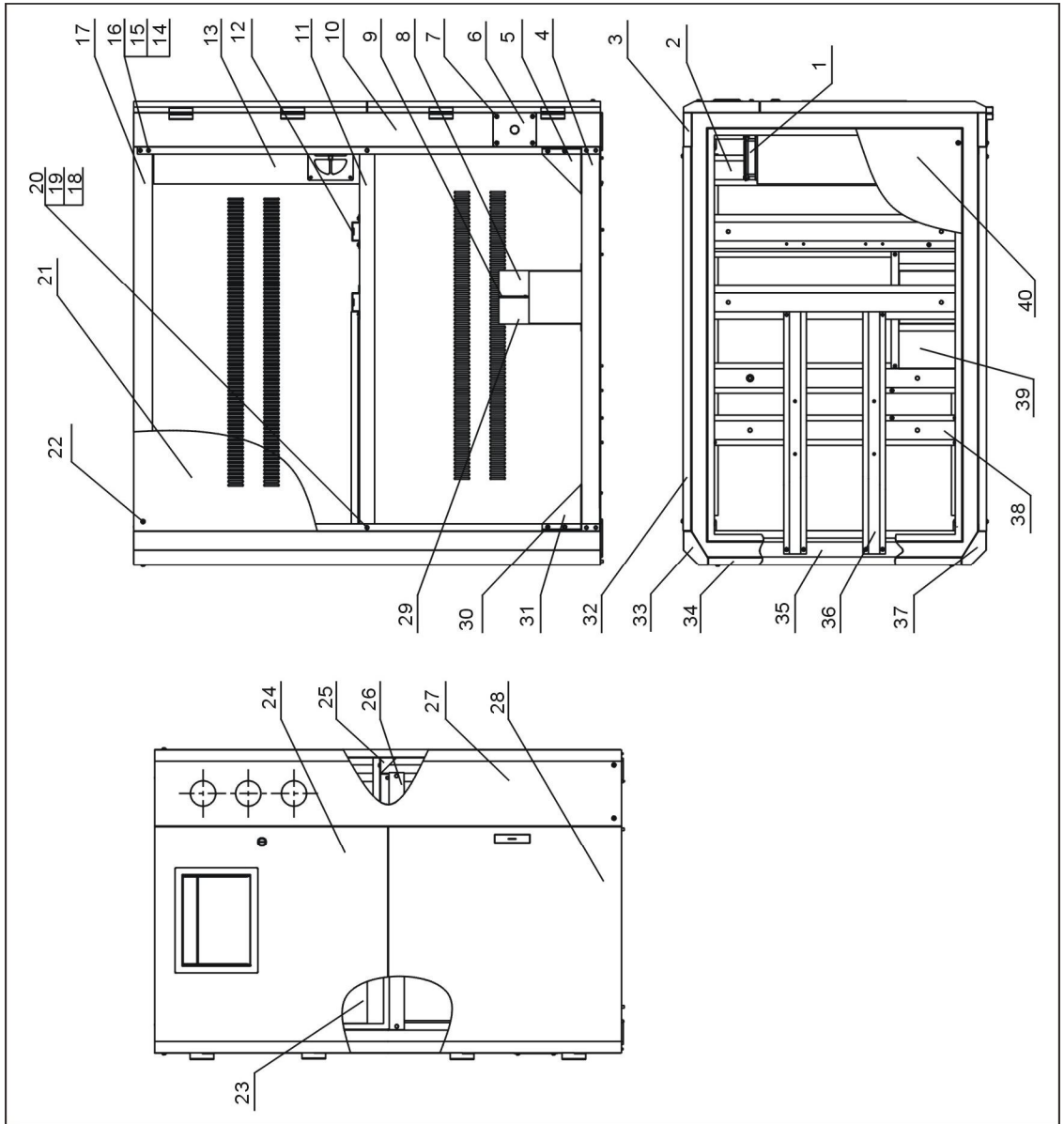

Picture 2-2: Structure Chart (STC-607-3W)

## 2.2.2 Structure Chart Parts List (STC-607-3W)

Table 2-1: Structure Chart Parts List (STC-607-3W)

No.	Name	Parts No.	No.	Name	Parts No.
1	Air exhaust fan	YM30121200400	21	Side plate (left)	-
2	Floor beam of compressor	-	22	Belt M6×30	YW63063000000
3	Right front stand column	-	23	Base plate of electrical cabinet	-
4	Base frame	-	24	Upper front door plate	-
5	Triangle (left)	-	25	Right middle beam	-
6	Clamp fixed plate	-	26	Support beam of electrical cabinet	-
7	Screw M5×10	YW62051000100	27	Gauge plate	-
8	Plate heat exchanger clamp 1	-	28	Lower front door plate	-
9	Self-tapping screw M5×10	YW67051000000	29	Plate heat exchanger clamp 2	-
10	Left front stand column	-	30	Bolt M6×15	YW63061500000
11	Left middle beam	-	31	Triangle (right)	-
12	Support beam of water tank	-	32	Side plate (right)	-
13	Electrical cabinet	-	33	Right back stand column	-
14	Spring washer	YW65006000100	34	Back plate	-
15	Flat washer	YW66061300000	35	Back middle beam	-
16	Hexagon head bolt M6×20	YW60062000100	36	Support beam of heating tank	-
17	Top frame	-	37	Left back stand column	-
18	Spring washer 6	YW65008000100	38	Base beam medium pump	-
19	Flat washer 6	YW66082200100	39	Plate heat exchanger base plate	-
20	Hexagon head bolt M6×20	YW60082000300	40	Top plate	-

\* means possible broken parts. \*\* means easy broken parts. Spare backup is suggested. Please confirm the version number of the manual before you order to ensure the stock number and the parts are consistent.

### 2.2.3 Water System Diagram (STC-607-3W)

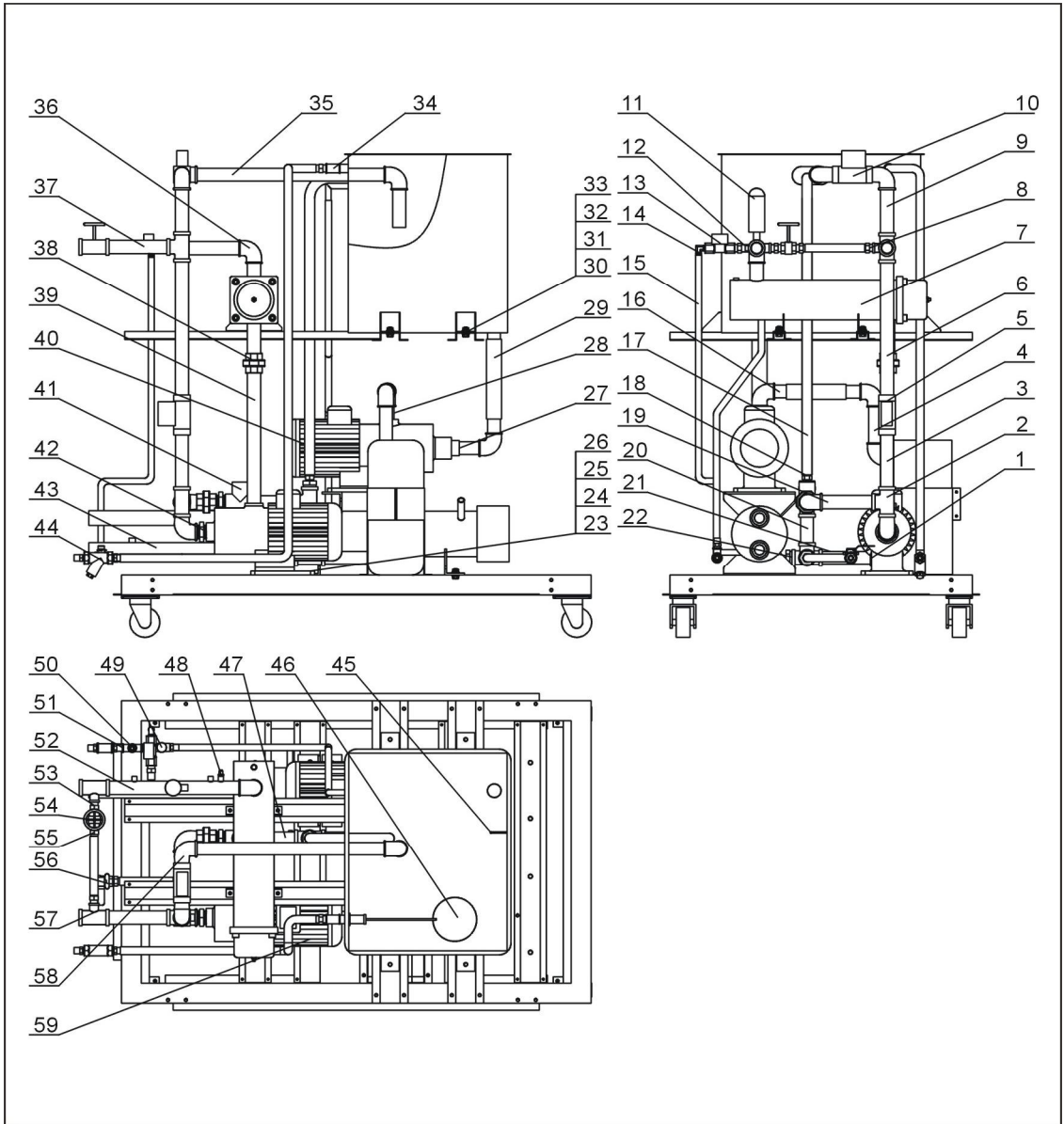

Picture 2-3: Water System Diagram (STC-607-3W)

## 2.2.4 Water System Parts List (STC-607-3W)

Table 2-2: Water System Parts List (STC-607-3W)

No.	Name	Parts No.	No.	Name	Parts No.
1	Stainless steel direct connection 1"	YW51010000000	31	Flat washer 6	YW66061300000
2	Stainless steel T joint 1"	YW52103040000	32	Spring washer 6	YW65006000100
3	Stainless steel tube 13	-	33	Nut M6	YW64000600300
4	Stainless steel tube 1	-	34	Stainless steel direct joint 1/2"	YW51010200000
5	Normally open solenoid valve 1"	YE32225800000	35	Stainless steel tube 10	-
6	Stainless steel tube 2	-	36	Stainless steel elbow 1"	YW53010000000
7	Heating tank assembly	-	37	Stainless steel tube 11	-
8	Copper inserted core 1/2"	BH12121200210	38	Stainless steel loose joint 1"	YR20000100100
9	Stainless steel tube 3	-	39	Stainless steel tube12	-
10	Normally closed solenoid valve 1"	YE32220800000	40	Pump	YM21044000100
11	Safety valve	BW05100000050	41	Check valve 1"	YW59100000000
12	Copper pipe coupler 3/8"	BH12030800110	42	Stainless steel inner joint 1"	YW55001000000
13	Solenoid valve 3/8"	YE32215400000	43	Galvanized stainless tube	-
14	Copper connector (L type)3/8"	YW04030800600	44	Y type filter 1/2"	YW57010200000
15	Copper tube 1	-	45	K type thermocouple	-
16	Stainless steel tube 4	-	46	Floating ball switch 1/2"	YW59010200000
17	Copper tube 2	-	47	T joint welded tube	-
18	Copper stretch connector 1	-	48	Copper connector 1/4"PT×1/4"H	BH12010400410
19	Stainless steel tube 5	-	49	Check valve 1/2"	YW59102000000
20	Stainless steel tube 6	-	50	Copper connector 1/2"PT×3/8"H	BH12030800210
21	Stainless steel tube 7	-	51	Stainless steel T joint 1/2"	YW52010200000
22	Copper stretch connector 2	-	52	Stainless steel tube 14	-
23	Hexgon head bolt M8×30	YW60083000200	53	Copper pipe coupler 1/2"PT	BH12010200010

24	Flat washer 8	YW65008000100	54	Sluice valve 1/2"	YW50010200000
25	Spring washer 8	YW65008000100	55	Copper connector 1/2"PT×1/2"H	BH12010200210
26	Nut M8	YW64080600000	56	Copper globe valve 1/2"	YW50010200100
27	Stainless steel tube 8	-	57	Stanless steel T joint 1" ×1/2"	YW52101200000
28	Stainless steel tube 9	-	58	Stainless steel street elbow 1"	YW53101000000
29	Black rubber tube inner diameter 32mm	YR60320500000	59	Pump	YM20024000000
30	Hexgon head bolt M6×20	YW60062000100			

\* means possible broken parts. \*\* means easy broken parts. Spare backup is suggested.  
Please confirm the version number of the manual before you order to ensure the stock  
number and the parts are consistent.

### 2.2.5 Refrigerant System Diagram (STC-607-3W)

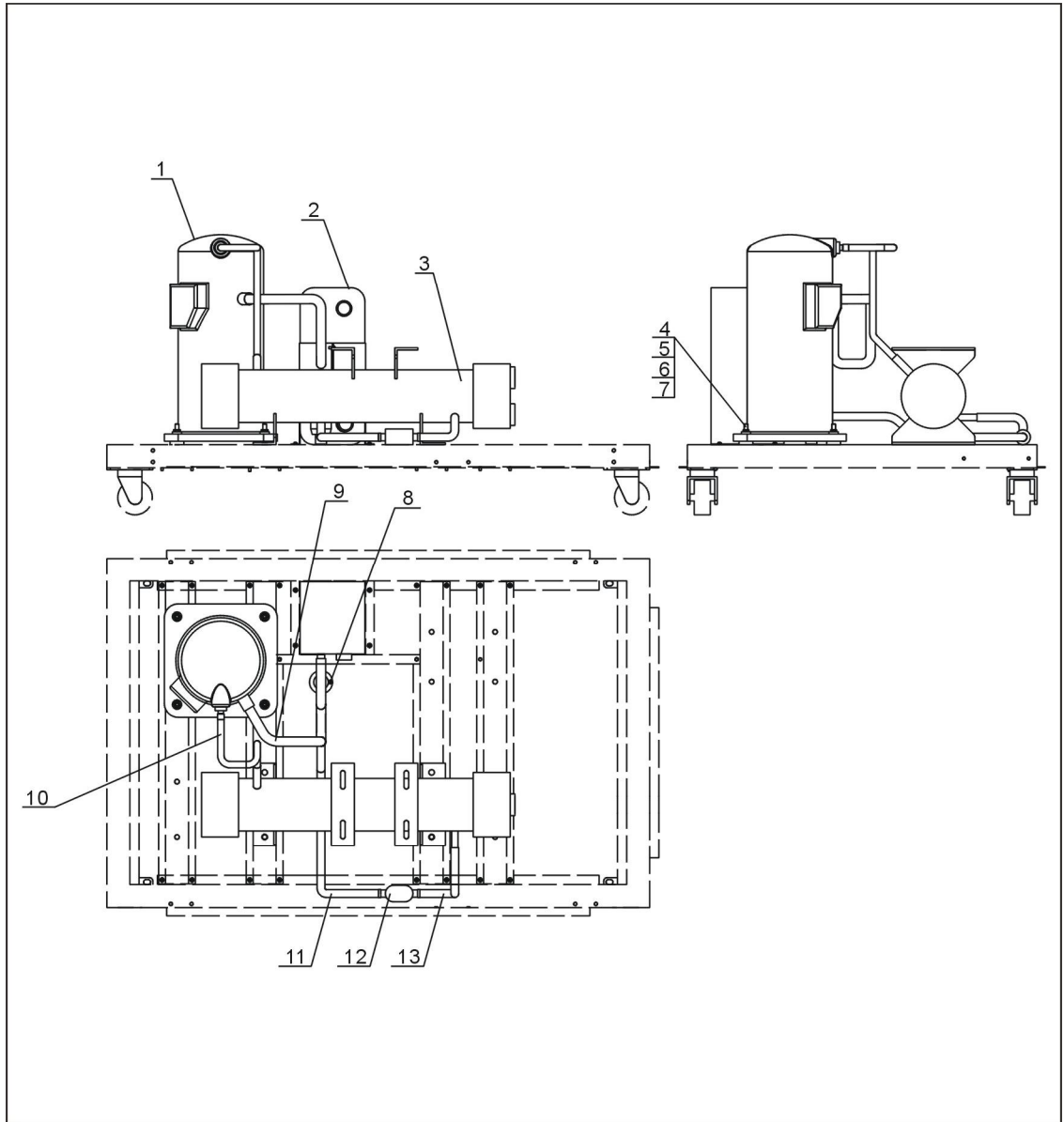

Picture 2-4: Refrigerant System Diagram (STC-607-3W)

## 2.2.6 Refrigerant System Parts List (STC-607-3W)

Table 2-3: Refrigerant System Parts List (STC-607-3W)

No.	Name	Parts No.	No.	Name	Parts No.
1	Compressor	YM70340000000	8	Heat expansion valve	YW85000300100
2	Evaporator	-	9	Air return valve	-
3	Condenser	-	10	Air exhaust	-
4	Hexgon head bolt M8×40	YW60080400000	11	Solenoid valve 1	-
5	Hexgon nut M8	YW64080600000	12	Drier filter EK-053	YW85005300000
6	Flat washer 8	YW66081600000	13	Solenoid valve 2	-
7	Spring washer 8	YW65008000200			

\* means possible broken parts. \*\* means easy broken parts. Spare backup is suggested. Please confirm the version number of the manual before you order to ensure the stock number and the parts are consistent.

### 2.2.7 General Assembly Diagram (STC-607-3W)

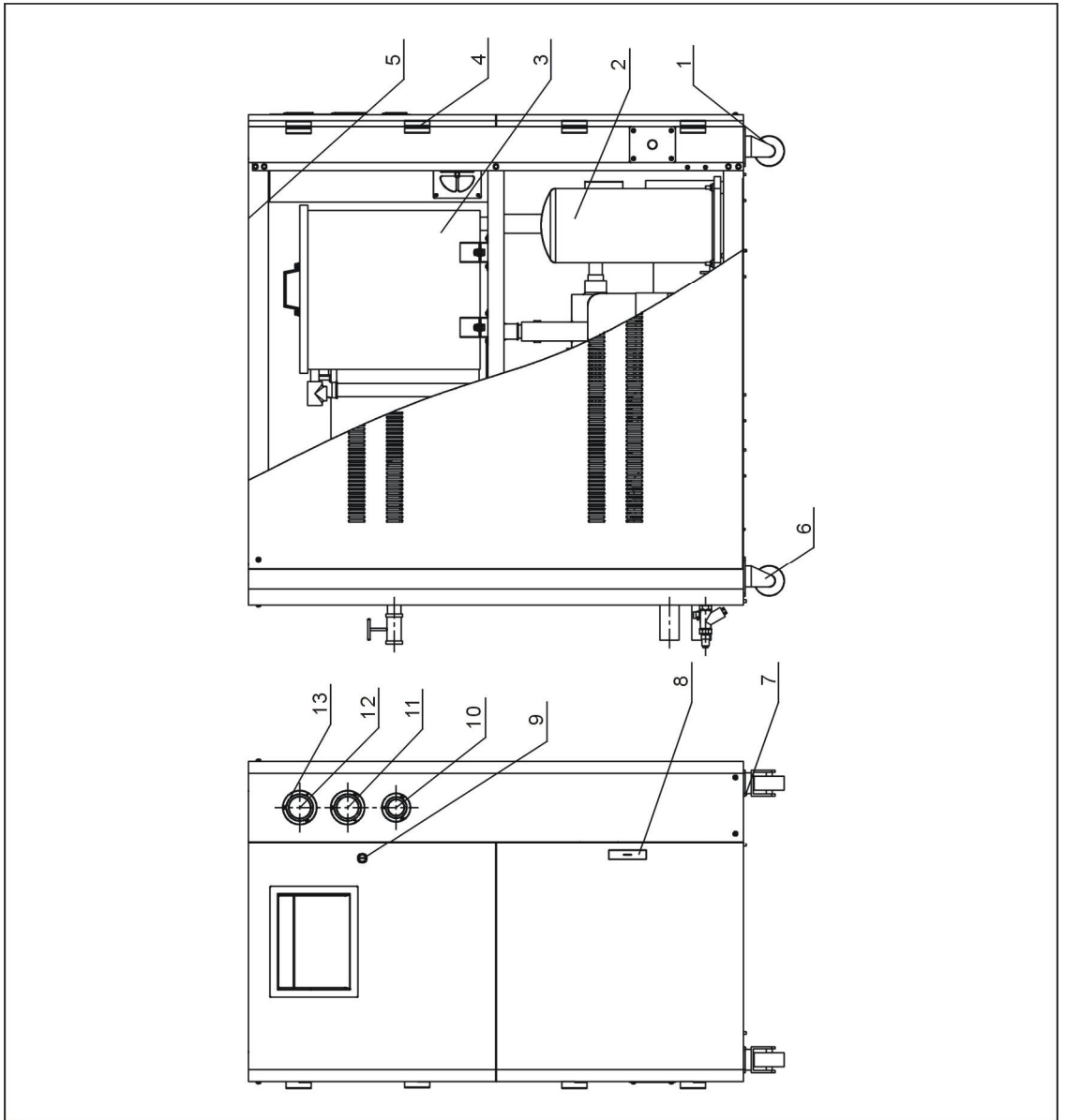

Picture 2-5: General Assembly Diagram (STC-607-3W)



## 2.2.8 General Assembly Parts List (STC-607-3W)

Table 2-4: General Assembly Parts List (STC-607-3W)

No.	Name	Parts No.	No.	Name	Parts No.
1	Braking caster	YW03000300000	8	Door lock of electrical cabinet	YW00717100000
2	Refrigerant system assembly	-	9	Door lock	YW00000000100
3	Water system assembly	-	10	Water pressure gauge 0~10kg	YW85001000100
4	Hinge	YW06203100400	11	Low pressure guage	YW85601500100
5	Sheet metal parts assembly	-	12	High pressure gauge	YW85603500100
6	Movable caster	YW03000300200	13	Screw M4×5	YW62040500000
7	Screew M6×20	YW61062000000			

\* means possible broken parts. \*\* means easy broken parts. Spare backup is suggested. Please confirm the version number of the manual before you order to ensure the stock number and the parts are consistent.

### 2.2.9 Assembly Drawing (STC-910-5W)

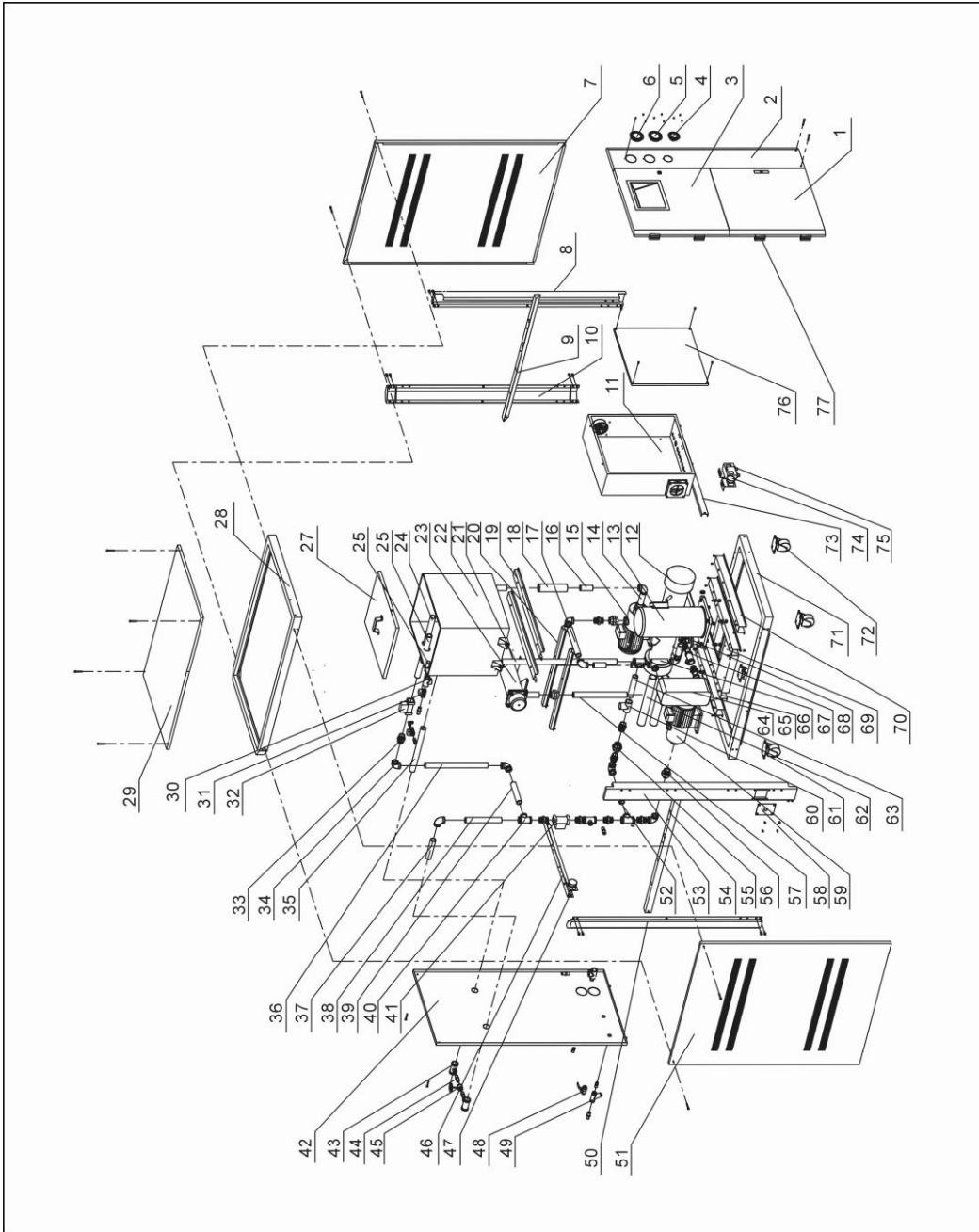

Picture 2-6: Assembly Drawing (STC-910-5W)

## 2.2.10 Parts List (STC-910-5W)

Table 2-5: Parts List (STC-910-5W)

No.	Name	Part No.	No.	Name	Part No.
1	Front lower door	-	28	Roof frame	-
2	Meter board	-	29	Top plate	-
3	Front upper door	-	30	Zinc-coated pipe tee junction 1/2"	YW52121200000
4	Water pressure gauge	YW85001000100	31	1/2" solenoid valve	YE32215400000
5	Low pressure gauge	YW85601500000	32	Solenoid valve 1"	-
6	High pressure gauge	YW85603500000	33	Zinc-coated pipe inner joint 1"	YW50000100000
7	Side plate (Right)	-	34	Zinc-coated pipe elbow 1"	YW53100000000
8	Right front standing pole	-	35	Zinc-coated pipe 8	-
9	Right middle beam	-	36	Zinc-coated pipe 11	-
10	Right rear standing pole	-	37	Zinc-coated pipe 7	-
11	Electric control cabinet	-	38	Zinc-coated pipe 1	-
12	Condenser	-	39	Zinc-coated pipe 9	-
13	Compressor ZB38KQ	-	40	Zinc-coated pipe tee junction 1"	YW52000100000
14	Pump inlet connector	-	41	Solenoid valve 1"	-
15	Chilled water pump CHLF4-40	YM20044000000	42	Raer board	-
16	Zinc-coated pipe 19	-	43	Zinc-coated pipe tee junction 1"x1/2"	YW52101200100
17	Zinc-coated pipe 17	-	44	Copper Teflon pipe connector 1/2PT*1/2H	BH12010200210
18	Black rubber tubing	YR60320500000	45	Gate valve 1/2"	YW50010200000
19	Water tank support beam	-	46	Raer middle beam	-
20	Heating barrel support beam	-	47	EGO	YE21503000000
21	Zinc-coated pipe 3	-	48	Ball valve 1/2"	YW50010200100
22	Water tank	-	49	Y" type filter ballvalve 1/2"	YW57010200000
23	Heating barrel	-	50	Left rear standing pole	-
24	Zinc-coated pipe 10	-	51	Side plate (Left)	-
25	Zinc-coated pipe 18	-	52	Zinc-coated pipe 15	-
26	Floating ball	YW59010200000	53	Left front standing pole	-
27	Water tank cover	-	54	Left middle beam	-

No.	Name	Part No.	No.	Name	Part No.
55	Zinc-coated pipeloose joint 1"	YW54000100000	67	Zinc-coated pipe 6	-
56	Zinc-coated pipe inner thread joint 1 1/4"*1"	-	68	Thermostatic expansion valve AAE5HC	YW85000500100
57	Zinc-coated pipe 16	-	69	Plate exchang bottom board	-
58	Clip fixed board	-	70	Compressor bottom beam	-
59	Media pump CHLF4-40	YM20044000000	71	Bottom frame	-
60	One-way valve 1"	YW59100000000	72	Front active castor	YW03000300200
61	Back brake castor	YW03000300000	73	Electrical control support beam	-
62	Zinc-coated pipe 14	-	74	Anti-freezing switch	YW85071100000
63	Zinc-coated pipe 4	-	75	Hi-LO pressure switch	YE90083000100
64	Plate evaporator	-	76	Electrical control bottom board	-
65	Media pump bottom beam	-	77	Hinge	YW06203100400
66	Zinc-coated pipe 12	-			

\* means possible broken parts. \*\* means easy broken part and spare backup is suggested.  
Please confirm the version of manual before placing the purchase order to guarantee that the item No. of spare part is in accordance with the real object.

### 2.2.11 Frame Drawing (STC-1215-8W)

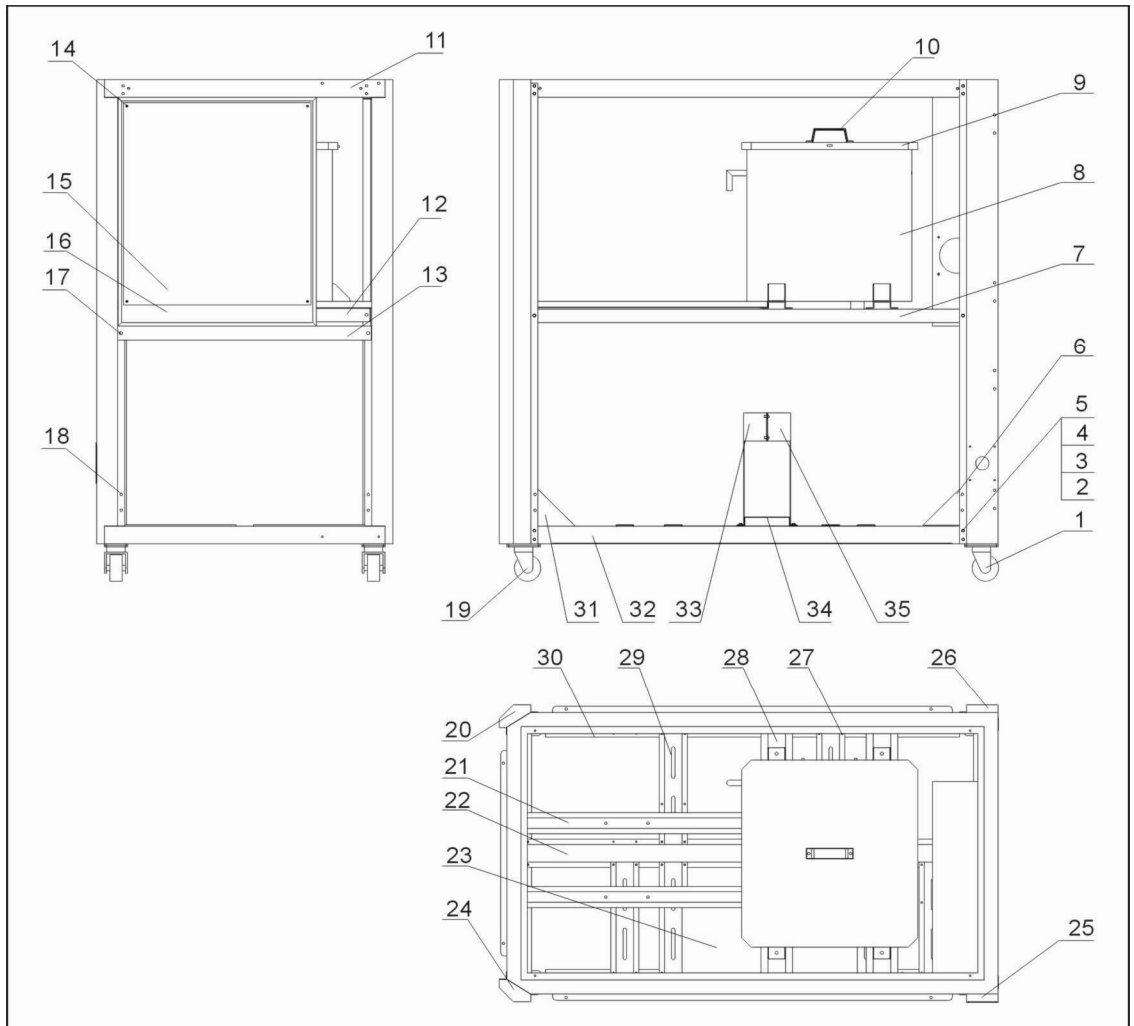

Picture 2-7: Frame Drawing (STC-1215-8W)

## 2.2.12 Parts List (STC-1215-8W)

Table 2-6: Parts List (STC-1215-8W)

No.	Name	Part No.	No.	Name	Part No.
1	Movable black rubber caster 3"PP	YW03000300200	19	Black rubber braking caster 3"PP	YW03000300000
2	Outer hexagon screw M6×20	YW60062000100	20	Back right stand column	-
3	Flat washer 6	YW66061300000	21	Heating tank support	-
4	Spring washer 6	YW65006000100	22	Lower middle beam	-
5	Nut M6	YW64000600300	23	Base board for plate heat exchanger 1	-
6	Triangle plate (left)	-	24	Left back stand column	-
7	Middle beam (left)	-	25	Left front stand column	-
8	Water tank body	-	26	Right front stand column	-
9	Water tank lid	-	27	Thick head screw M6×15	YW63061500000
10	Square handle	BW20012000040	28	Water tank support	-
11	Upper frame	-	29	Lower beam	-
12	Back middle beam	-	30	Middle beam (right)	-
13	Electrical cabinet support	-	31	Triangle plate (right)	-
14	Flat head screw M5×20	YW62052000000	32	Base frame	-
15	Electrical base plate	-	33	Clamp for plate heat exchanger 1	-
16	Electrical cabinet	-	34	Base board for plate heat exchanger 2	-
17	Outer hexagon screw M8×20	YW61820000200	35	Clamp for plate heat exchanger 2	-
18	Flat head screw M6×10	YW62061000000			

\* means possible broken parts. \*\* means easy broken part and spare backup is suggested. Please confirm the version of manual before placing the purchase order to guarantee that the item No. of spare part is in accordance with the real object.

### 2.2.13 Water System Diagram (STC-1215-8W)

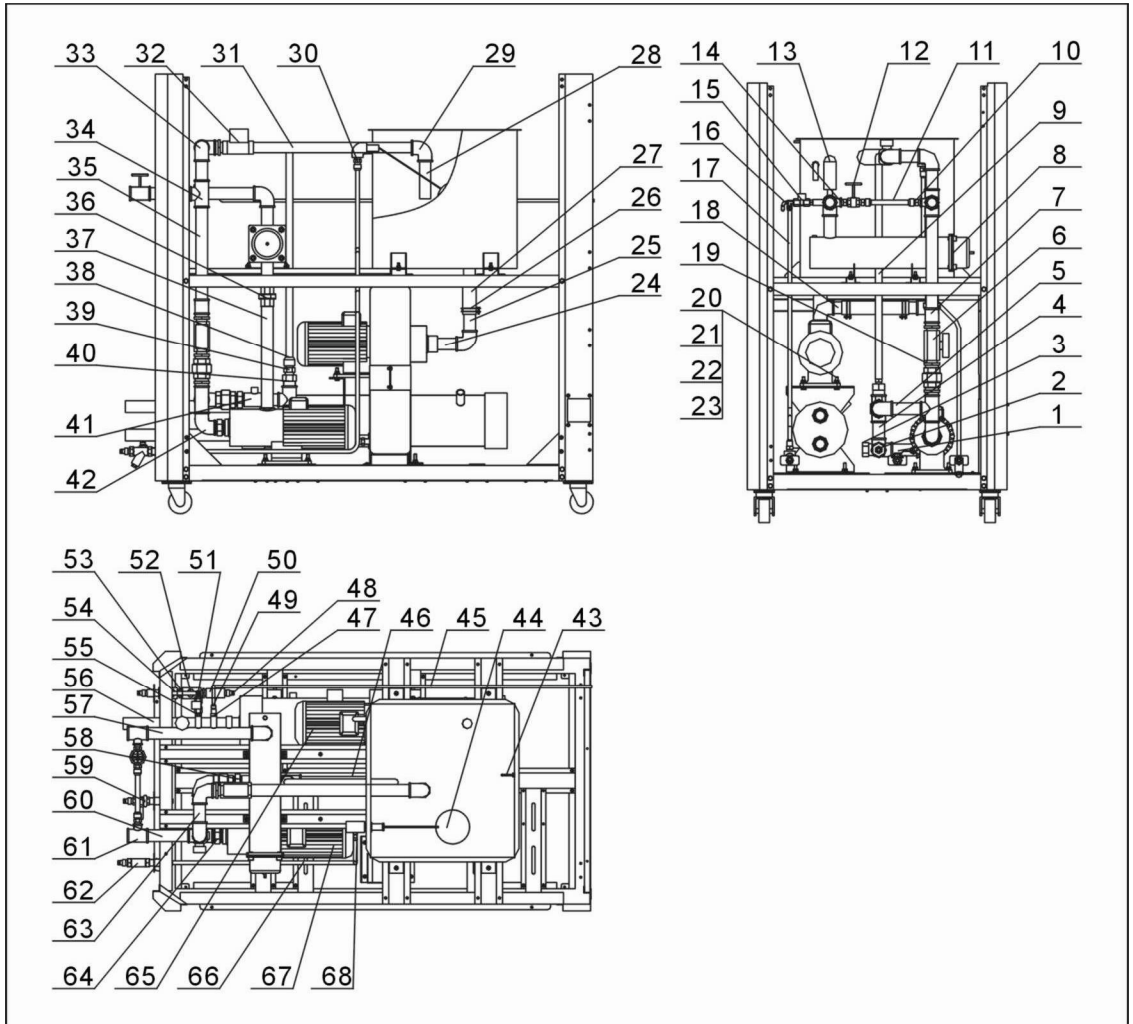

Picture 2-8: Water System Diagram (STC-1215-8W)

## 2.2.14 Parts List (STC-1215-8W)

Table 2-7: Parts List (STC-1215-8W)

No.	Name	Part No.	No.	Name	Part No.
1	Stainless steel pipe 1	-	25	Stainless steel pipe 12	-
2	Copper stretch connector 2	-	26	Steel wire pipe bundle 57mm	YW02005700000
3	Copper stretch connector 3	-	27	Fabric hose 42mm	YR60420300100
4	Stainless steel pipe 4	-	28	Stainless steel pipe 10	-
5	Stainless steel pipe 5	-	29	Stainless steel elbow 1"	YW53010000000
6	Normally open solenoid valve 1"	YE32225800000	30	Copper connector 1/2PT"x1/2"H	BH12010200210
7	Stainless steel direct connection 1-1/4"	YW51012500000	31	Stainless steel pipe 9	-
8	Heating tank assembly	-	32	Normally closed solenoid valve 1"	YE32220800000
9	Copper pipe 1	-	33	Stainless steel elbow 1-1/4"	YW53012500000
10	Flare nut 1/2"	BH12000401110	34	Stainless steel T-joint 1-1/4"	YW52102500000
11	Copper pipe 2	-	35	Stainless steel pipe 6	-
12	Sluice valve 1/2"	YW50010200000	36	Stainless steel loose joint 1-1/4"	YW54012500000
13	Safety valve	BW05100000050	37	Stainless steel pipe 7	-
14	Copper nipple 1/2"	BH12010200010	38	Flare nut 3/4"	BH12000631010
15	Solenoid valve 3/8"	YE32215400000	39	Copper connector 3/4PT"x3/4"H	BH12030400610
16	Copper connector 3/8"PT×3/8H(L type)	YW04030800300	40	Copper stretch connector 1	-
17	Copper pipe 3	-	41	Non-return valve 1-1/4"	YW59125000000
18	Stainless steel pipe 11	-	42	Stainless steel street elbow 1-1/4"	YW53001200100
19	Stainless steel inner joint 1-1/4"x1"	YW55114800000	43	Thermocouple	-
20	Nut M8	YW64080600000	44	Floating-ball valve 1/2"	YW59010200000
21	Flat washer 8	YW66082200100	45	Copper pipe 5	-
22	Spring washer 8	YW65008000100	46	Stainless steel pipe 2	-
23	Outer hexagon screw M8×30	YW60083000200	47	Teflon pipe coupler 1/4"	YW04010400400
24	Stainless steel pipe 3	-	48	Copper insert 1/2"	BH12161230010



No.	Name	Part No.	No.	Name	Part No.
49	Flare nut 1/4"	BH12010401010	59	Copper globe valve 1/2"	YW50010200100
50	Non-return valve 1/2"	YW59102000000	60	Stainless steel pipe 13	-
51	Flare nut 3/8"	BH12030801010	61	Stainless steel T-joint 1-1/4"x1/2"	YW52125500000
52	Copper connector 3/8"Hx1/2"PT	BH12030800210	62	Y-type strainer 1/2"	YW57010200000
53	Stainless steel inner joint 1/2"	YW55010200000	63	Stainless steel pipe 8	-
54	Stainless steel T-joint 1/2"	YW52010200000	64	Stainless steel inner joint 1-1/2"x1-1/4"	YW55114600000
55	Copper nipple 3/8"	BH12030800110	65	Pump (CHLF4-50)	YM20502200000
56	Galvanized steel pipe	-	66	Copper pipe 4	-
57	Stainless steel pipe 14	-	67	Pump (CHLF8-30)	YM20083000000
58	Stainless steel inner joint 1-1/4"	YW52010200000	68	Stainless steel elbow 1/2"	YW53001200100

\* means possible broken parts. \*\* means easy broken part and spare backup is suggested. Please confirm the version of manual before placing the purchase order to guarantee that the item No. of spare part is in accordance with the real object.

### 2.2.15 Refrigerant System Diagram (STC-1215-8W)

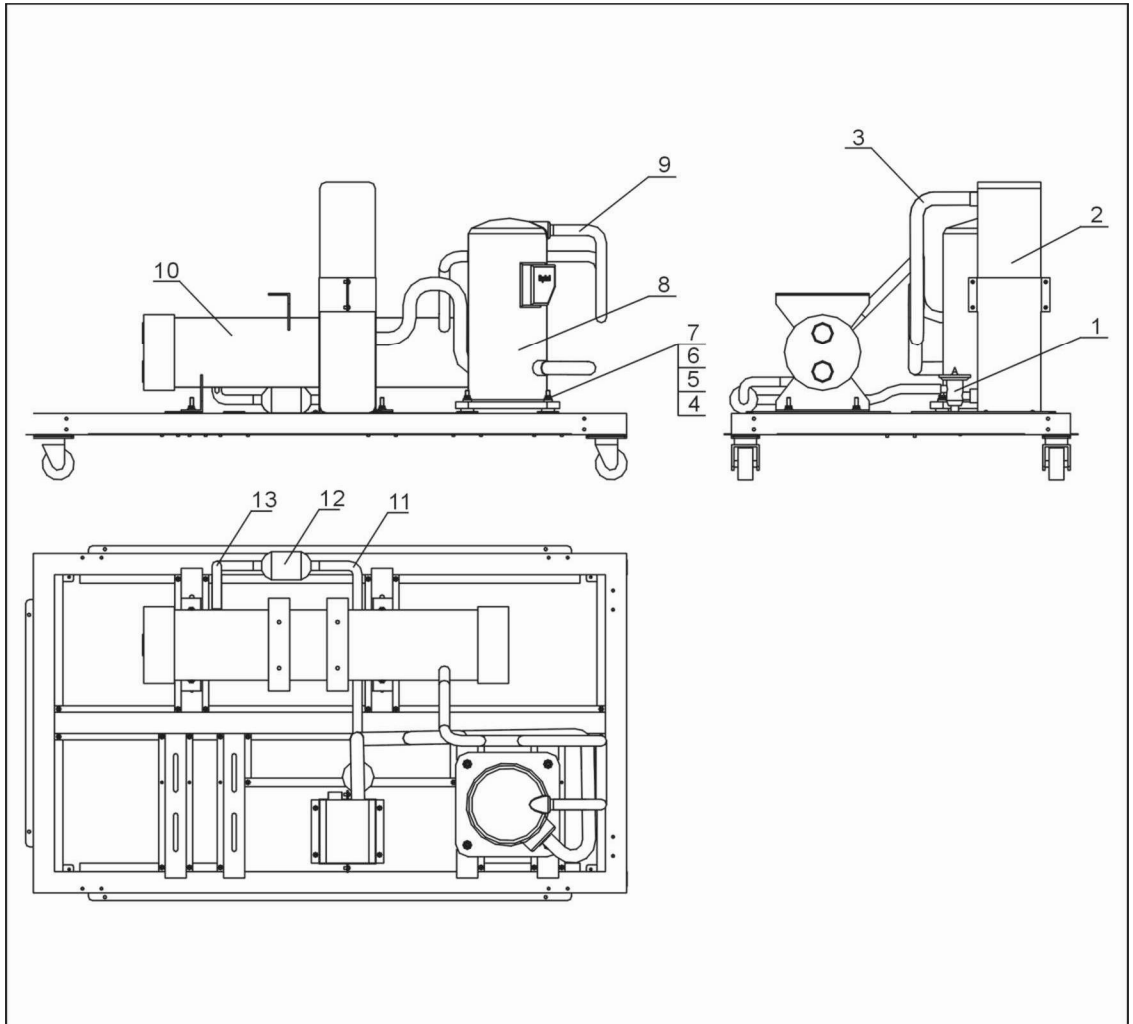

Picture 2-9: Refrigerant System Diagram (STC-1215-8W)

## 2.2.16 Parts List (STC-1215-8W)

Table 2-8: Parts List (STC-1215-8W)

No.	Name	Part No.	No.	Name	Part No.
1	Heat expansion valve	YW85063120100	8	Compressor	YM70840000000
2	Plate heat exchanger	-	9	Air exhaust pipe	-
3	Air suction pipe	-	10	Condenser	-
4	Outer hexagon screw M8×40	YW60080400000	11	Liquid pipe 1	-
5	Flat washer 8	YW66082200100	12	Drier filter (EK-164)	YW85016400000
6	Spring washer 8	YW65006000100	13	Liquid pipe 2	-
7	Nut M8	YW64080600000			

\* means possible broken parts. \*\* means easy broken part and spare backup is suggested. Please confirm the version of manual before placing the purchase order to guarantee that the item No. of spare part is in accordance with the real object.

### 2.2.17 System Structure Drawing (STC-1215-8W)

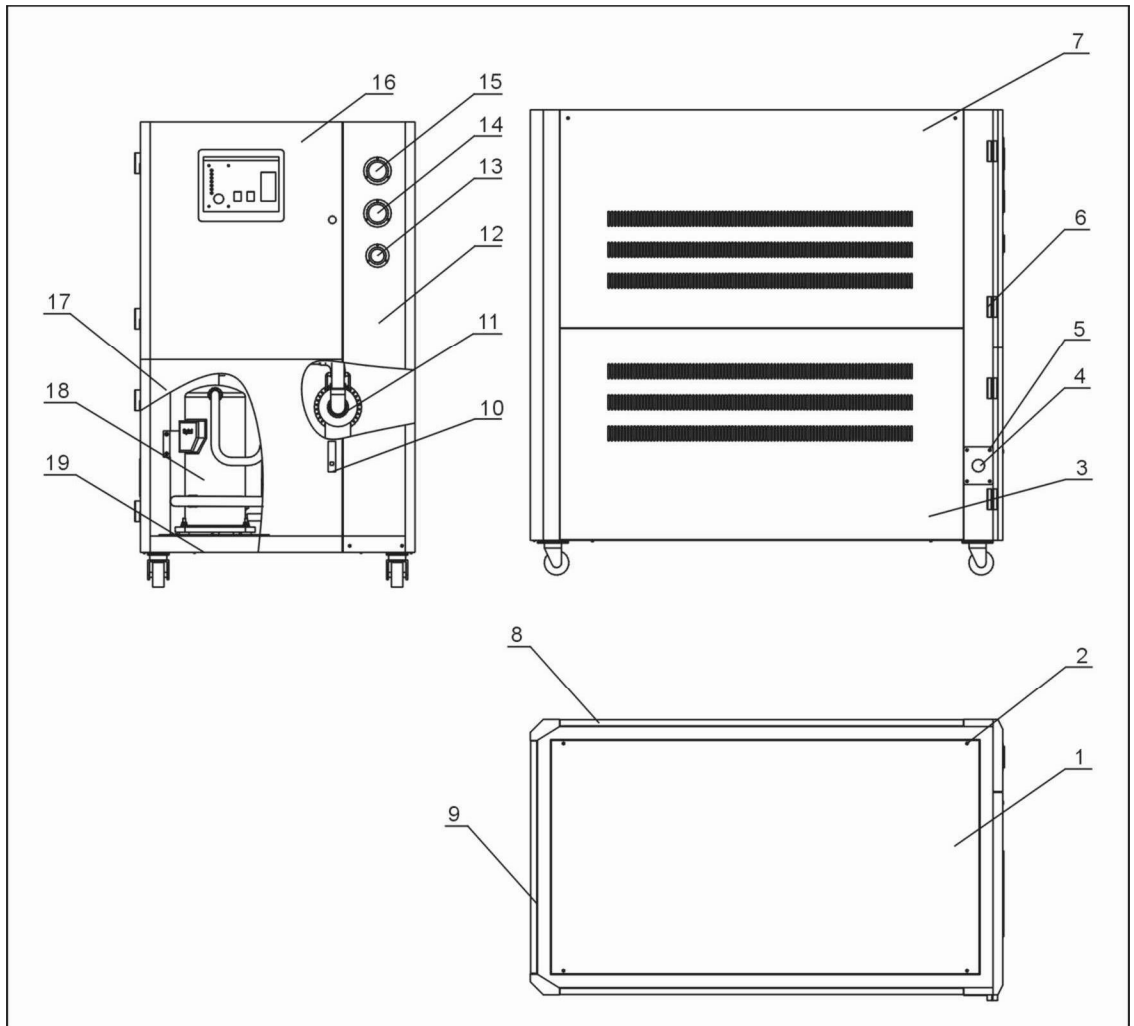

Picture 2-10: System Structure Drawing (STC-1215-8W)

## 2.2.18 Parts List (STC-1215-8W)

Table 2-9: Parts List (STC-1215-8W)

No.	Name	Part No.	No.	Name	Part No.
1	Top plate	-	11	Water system	-
2	Thick head screw M6*30	YW63063000000	12	Gauge plate	-
3	Side plate 3	-	13	Water pressure gauge	YW85001000100
4	Line jig fixed plate	-	14	Low pressure gauge	YW85601800000
5	Flat head screw M6*15	YW62061500000	15	High pressure gauge	YW85603800000
6	Hinge	YW06203100400	16	Upper door plate	-
7	Side plate 1	-	17	Lower door plate	-
8	Side plate 2	-	18	Refrigerant system	-
9	Rear plate	-	19	Frame	-
10	Cabinet door lock	YW00717100000			

\* means possible broken parts. \*\* means easy broken part and spare backup is suggested. Please confirm the version of manual before placing the purchase order to guarantee that the item No. of spare part is in accordance with the real object.