

2.2 Drawing and Parts List

2.2.1 SGB-200-2 Assembly Drawing

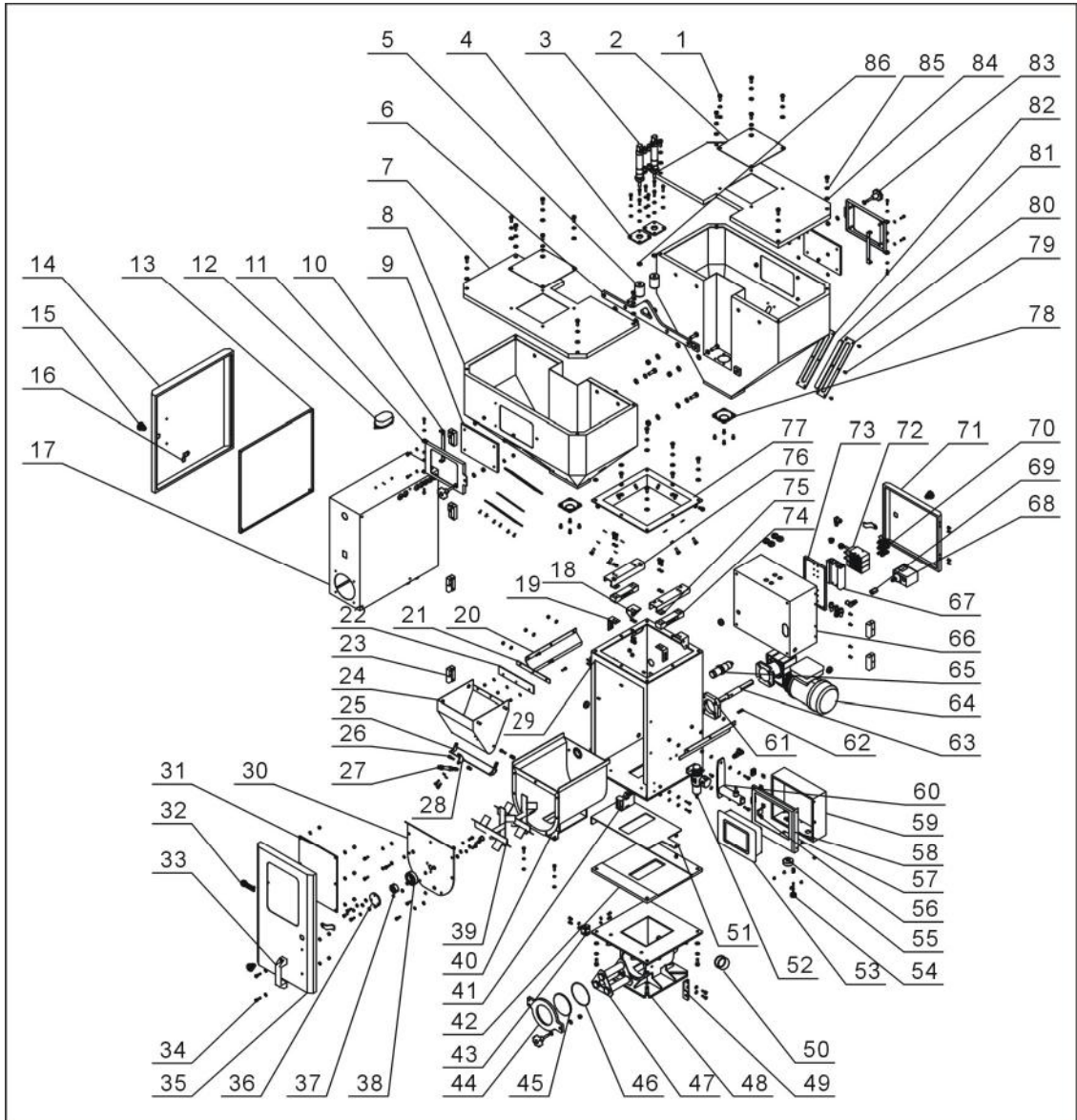

Remarks: Please refer to material List 2.2.2 for specific explanation of the Arabic numbers in parts drawing.

Picture 2-3: SGB-200-2 Assembly Drawing

2.2.2 SGB-200-2 Parts List

Table 2-1: Parts List (SGB-200-2)

No.	Name	Part No.	No.	Name	Part No.
1	Bolt M8×20	YW60082000300	29	Body welding	-
2	Square plate 200×200	YW09202000000	30	Mixing tank cover	-
3	Cylinder of metering valve*	YE31256010000	31	Body door acryl	-
4	Mounting plate of cylinder	-	32	Aluminum Shini trademark 81×31	YP30813100100
5	Welding drawing of metering valve	-	33	Aluminum handle 120L	BW20012000040
6	Hanger plate	-	34	Socket head cap screw M6×20	YW61062000000
7	Hopper cover	-	35	Door welding	-
8	Hopper welding	-	36	Bearing cover	-
9	Acrylic plate of clearance door	-	37	Self aligning ball bearing	YW09220200000
10	Clearance door hanger	-	38	Bearing seat	-
11	Clearance door	-	39	Paddle welding	-
12	Alarm light	YE83305100300	40	Mixing tank welding	-
13	Electric mounting plate	-	41	Inserted switch	YE16147600100
14	Electric cabinet door	-	42	Manual shut-off valve bearer	-
15	Gate lock	YW00000600000	43	Magnetic base hinge	BL01005020020
16	Separation blade of door lock	YW00040600000	44	Magnetic base door	-
17	Electric cabinet	-	45	Tempered glass 400~600kg	YW70406000000
18	Mounting plate of gravimetric sensor	-	46	Magnetic base spring	YW01040000000
19	Fixing plate of gravimetric sensor	-	47	Hopper magnet	BY10310000050
20	Mixing tank material fender	-	48	Magnetic base welding	-
21	Gravimetric hopper material fender trim strip	-	49	Magnetic base fittings	-
22	Gravimetric hopper material fender	-	50	Discharge pipe cap	-
23	Big hinge (left)	YW06203100400	51	Manual shut-off plate	-
24	Gravimetric hopper welding	-	52	Filter & pressure regulating valve	YE30421400000
25	Gravimetric hopper shut-off plate welding	-	53	Touch panel	YE80002400000
26	Shut-off cylinder screw	-	54	Bolt	YW69461600000
27	Gravimetric hopper cylinder	-	55	Touch panel cabinet supporting block	-
28	Shut-off plate cylinder mounting block	-	56	Sprue	-

No.	Name	Part No.	No.	Name	Part No.
57	Touch panel cabinet bade plate	-	72	Solenoid valve *MFH-5-4/8-B	YE32051800100
58	Touch panel cabinet cover	-	73	Solenoid valve mounting plate	-
59	Touch panel cabinet	-	74	Gravimetric sensor *LPS-6kg	YE15000600000
60	Touch panel support frame	-	75	Gravimetric hopper supporting block washer	-
61	Mixing motor bearer	-	76	Gravimetric hopper supporting block	-
62	Mixer shaft connecting key	-	77	Mounting plate of storage hopper	-
63	Mixing motor shaft	-	78	Discharge port of main metering valve	-
64	Gear motor	YM50402500000	79	Cross recess head screw M5×10	YW62051000000
65	Sensor*	YE15508200000	80	Sight-glass sheet iron (six holes)	YW09000600000
66	Solenoid valve cabinet	-	81	Acryl (six holes)	YR40001200000
67	Junction plate RS-1/8-3	YW82180300000	82	Sight-glass sheet iron (six holes)	YR40000600000
68	Barometric switch	YE90000800000	83	Star knob B typeM8×35	YR40083500000
69	Barometric switch changeover nut	-	84	Flat washer 8	YW66081600000
70	Air pipe quick coupling	YW80061800200	85	Spring washer 8	YW65008000100
71	Solenoid valve cabinet door	-	86	Hex thin nut M10×1.25	YW64101200400

* means possible broken parts.

** means easy broken part. and spare backup is suggested.

Please confirm the version of manual before placing the purchase order to guarantee that the item number of the spare part is in accordance with the real object.

2.2.3 SGB-200-3 Assembly Drawing

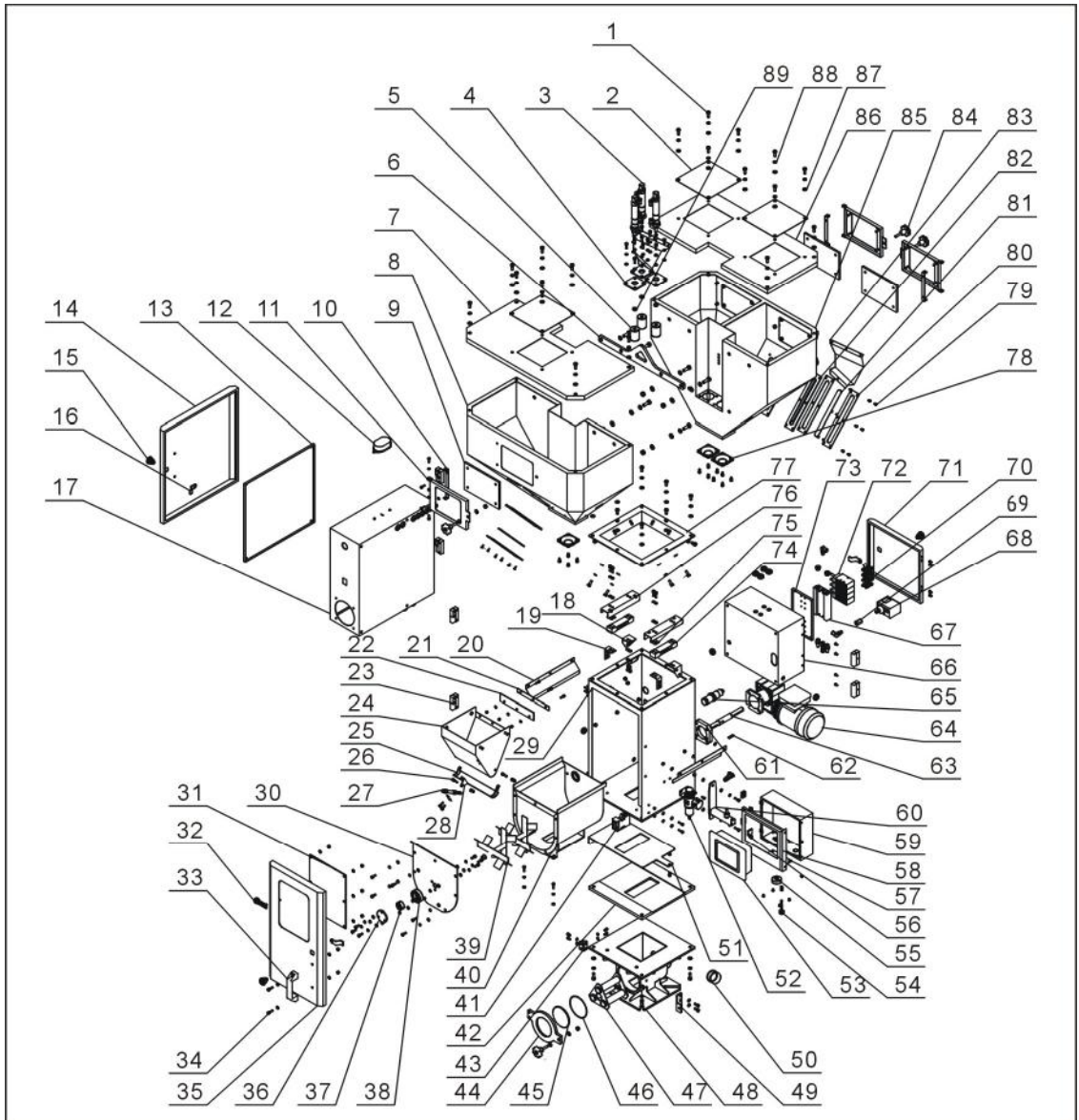

Remarks: Please refer to material List 2.2.4 for specific explanation of the Arabic numbers in parts drawing.

Picture 2-4: SGB-200-3 Assembly Drawing

2.2.4 SGB-200-3 Parts List

Table 2-2: Parts List (SGB-200-3)

No.	Name	Part No.	No.	Name	Part No.
1	bolt M8×20	YW60082000300	27	Gravimetric hopper cylinder	-
2	Square plate 200×200	YW09202000000	28	Shut-off plate cylinder mounting block	-
3	Metering valve cylinder*	YE31256010000	29	Body welding	-
4	Metering valve cylinder mounting plate	-	30	Mixing tank cover	-
5	Metering valve welding	-	31	Mixing tank cover	-
6	Hanger plate	-	32	Aluminum Shini trademark81×31	YP30813100100
7	Hopper cover	-	33	Aluminum handle120L	BW20012000040
8	Hopper welding	-	34	Socket head cap screwM6×20	YW61062000000
9	Acrylic plate of clearance door	-	35	Door welding	-
10	Clearance door trim strip	-	36	Bearing cover	-
11	Clearance door	-	37	Self aligning ball bearing	YW09220200000
12	Alarm light	YE83305100300	38	Bearing seat	-
13	Electric mounting plate	-	39	Paddle welding	-
14	Electric cabinet door	-	40	Mixing tank welding	-
15	Short circuit gate lock	YW00000600000	41	Inserted switch	YE16147600100
16	Separation blade of door lock	YW00040600000	42	Manual shut-off plate bearer	-
17	Electric cabinet	-	43	Magnetic base hinge	BL01005020020
18	gravimetric sensor mounting plate	-	44	Magnetic base door	-
19	gravimetric sensor fixing plate	-	45	Tempered glass400~600kg	YW70406000000
20	Mixing tank material fender	-	46	Magnetic base spring	YW01040000000
21	Gravimetric hopper material fender trim strip	-	47	Hopper magnet	BY10310000050
22	Gravimetric hopper material fender	-	48	Magnetic base welding	-
23	Big hinge (left)	YW06203100400	49	Magnetic base fittings	-
24	Gravimetric hopper welding	-	50	Discharge pipe cap	-
25	Gravimetric hopper shut-off plate welding	-	51	Manual shut-off plate	-
26	Shut-off cylinder screw	-	52	Filter & pressure regulating valve	YE30421400000

No.	Name	Part No.	No.	Name	Part No.
53	Touch panel	YE80002400000	72	Solenoid valve*MFH-5-4/8-B	YE32051800100
54	Bolt	YW69461600000	73	Solenoid valve mounting plate	-
55	Touch panel cabinet supporting block	-	74	gravimetric sensor*LPS-6kg	YE15000600000
56	Sprue	-	75	Gravimetric hopper supporting block washer	-
57	Touch panel cabinet base plate	-	76	Gravimetric hopper supporting block	-
58	Touch panel cabinet cover	-	77	Storage hopper mounting plate	-
59	Touch panel cabinet	-	78	Discharge port of main metering valve	-
60	Touch panel support frame	-	79	Cross recess head screwM5×10	YW62051000000
61	Mixing motor bearer	-	80	Sight-glass sheet iron (six holes)	YW09000600000
62	Mixer shaft connecting key	-	81	Acryl (six holes)	YR40001200000
63	Mixing motor shaft	-	82	Sight-glass sheet iron (six holes)	YR40000600000
64	Gear motor	YM50402500000	83	Air pipe cover	
65	Sensor*	YE15508200000	84	Star knob B typeM8×35	YR40083500000
66	Solenoid valve cabinet	-	85	Hooper welding	
67	Junction platePRS-1/8-3	YW82180300000	86	Hopper cover	
68	Barometric switch	YE90000800000	87	Flat washer8	YW66081600000
69	Barometric switch changeover nut	-	88	Spring washer8	YW65008000100
70	Air pipe quick coupling	YW80061800200	89	Hex thin nut M10×1.25	YW64101200400
71	Solenoid valve cabinet door	-			

* means possible broken parts.

** means easy broken part. and spare backup is suggested.

Please confirm the version of manual before placing the purchase order to guarantee that the item number of the spare part is in accordance with the real object.

2.2.5 SGB-200-4 Assembly Drawing

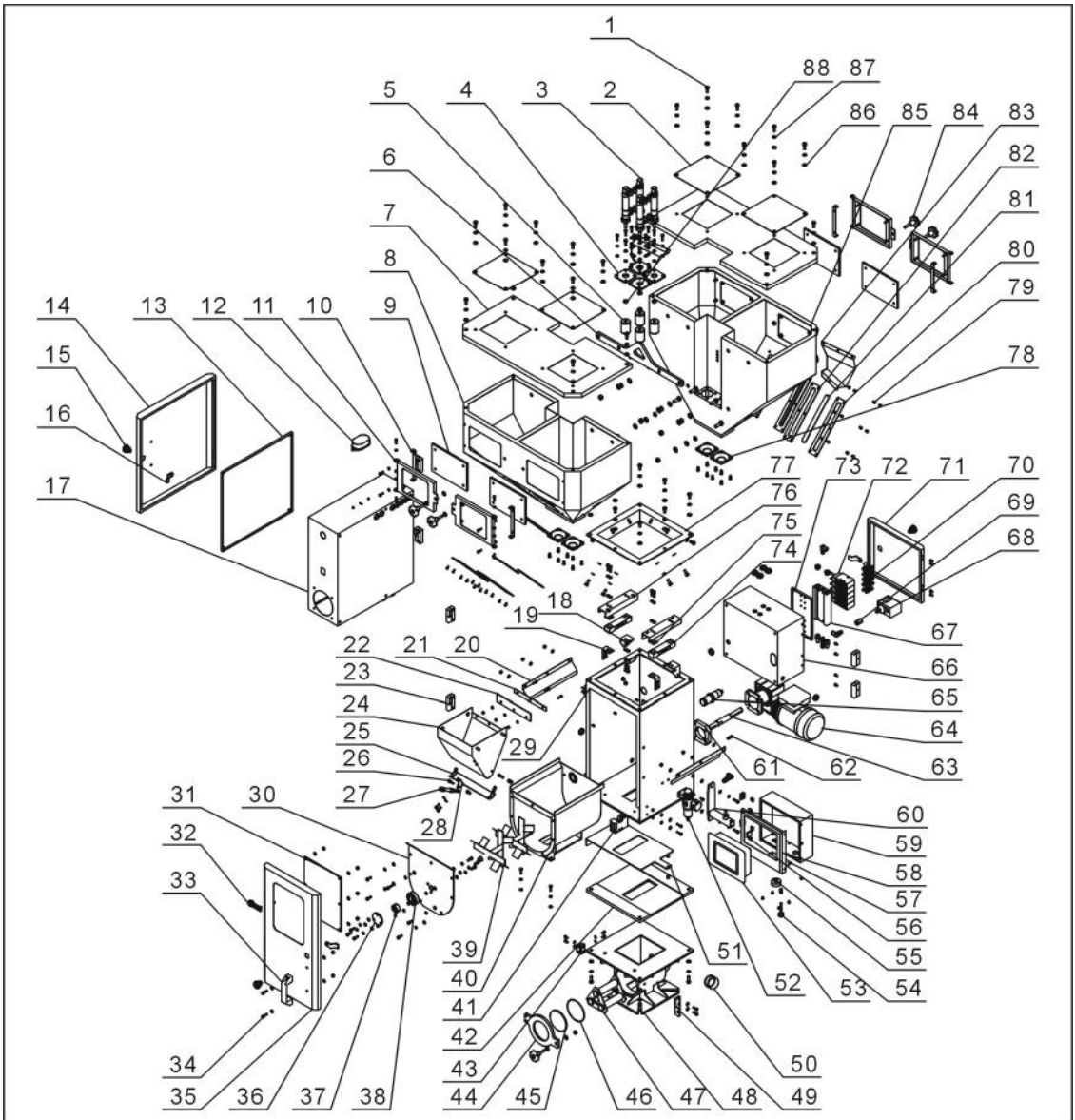

Remarks: Please refer to material List 2.2.6 for specific explanation of the Arabic numbers in parts drawing.

Picture 2-5: SGB-200-4 Assembly Drawing

2.2.6 SGB-200-4 Parts List

Table 2-3: Parts List (SGB-200-4)

No.	Name	Part No.	No.	Name	Part No.
1	BoltM8×20	YW60082000300	27	Gravimetric hopper cylinder	-
2	Square plate 200×200	YW09202000000	28	Shut-off plate cylinder mounting block	-
3	Metering valve cylinder*	YE31256010000	29	Body welding	-
4	Metering valve cylinder mounting plate	-	30	Mixing tank cover	-
5	Metering valve welding	-	31	Mixing tank cover	-
6	Hanger plate	-	32	Aluminum Shini trademark81×31	YP30813100100
7	Hopper cover	-	33	Aluminum handle120L	BW20012000040
8	Hopper welding	-	34	Socket head cap screwM6×20	YW61062000000
9	Acrylic plate of clearance door	-	35	Door welding	-
10	Clearance door trim strip	-	36	Bearing cover	-
11	Clearance door	-	37	Self aligning ball bearing	YW09220200000
12	Alarm light	YE83305100300	38	Bearing seat	-
13	Electric mounting plate	-	39	Paddle welding	-
14	Electric cabinet door	-	40	Mixing tank welding	-
15	Short circuit gate lock	YW00000600000	41	Inserted switch	YE16147600100
16	Separation blade of door lock	YW00040600000	42	Manual shut-off plate bearer	-
17	Electric cabinet	-	43	Magnetic base hinge	BL01005020020
18	gravimetric sensor mounting plate	-	44	Magnetic base door	-
19	gravimetric sensor fixing plate	-	45	Tempered glass400~600kg	YW70406000000
20	Mixing tank material fender	-	46	Magnetic base spring	YW01040000000
21	Gravimetric hopper material fender trim strip	-	47	Hopper magnet	BY10310000050
22	Gravimetric hopper material fender	-	48	Magnetic base welding	-
23	Big hinge (left)	YW06203100400	49	Magnetic base fittings	-
24	Gravimetric hopper welding	-	50	Discharge pipe cap	-
25	Gravimetric hopper shut-off plate welding	-	51	Manual shut-off plate	-
26	Shut-off cylinder screw	-	52	Filter & pressure regulating valve	YE30421400000

No.	Name	Part No.	No.	Name	Part No.
53	Touch panel	YE80002400000	71	Solenoid valve cabinet door	-
54	Bolt	YW69461600000	72	Solenoid valve*MFH-5-4/8-B	YE32051800100
55	Touch panel cabinet supporting block	-	73	Solenoid valve mounting plate	-
56	Sprue	-	74	gravimetric sensor*LPS-6kg	YE15000600000
57	Touch panel cabinet base plate	-	75	Gravimetric hopper supporting block washer	-
58	Touch panel cabinet cover	-	76	Gravimetric hopper supporting block	-
59	Touch panel cabinet	-	77	Storage hopper mounting plate	-
60	Touch panel support frame	-	78	Discharge port of main metering valve	-
61	Mixing motor bearer	-	79	Cross recess head screwM5×10	YW62051000000
62	Mixer shaft connecting key	-	80	Sight-glass sheet iron (six holes)	YW09000600000
63	Mixing motor shaft	-	81	Acryl (six holes)	YR40001200000
64	Gear motor	YM50402500000	82	Sight-glass sheet iron (six holes)	YR40000600000
65	Sensor*	YE15508200000	83	Air pipe cover	
66	Solenoid valve	-	84	Star knob B typeM8×35	YR40083500000
67	Junction platePRS-1/8-3	YW82180300000	85	Hooper welding	
68	Barometric switch	YE90000800000	86	Flat washer8	YW66081600000
69	Barometric switch changeover nut	-	87	Spring washer8	YW65008000100
70	Air pipe quick coupling	YW80061800200	88	Hex thin nut M10×1.25	YW64101200400

* means possible broken parts.

** means easy broken part. and spare backup is suggested.

Please confirm the version of manual before placing the purchase order to guarantee that the item number of the spare part is in accordance with the real object.

2.2.7 SGB-600-2 Assembly Drawing

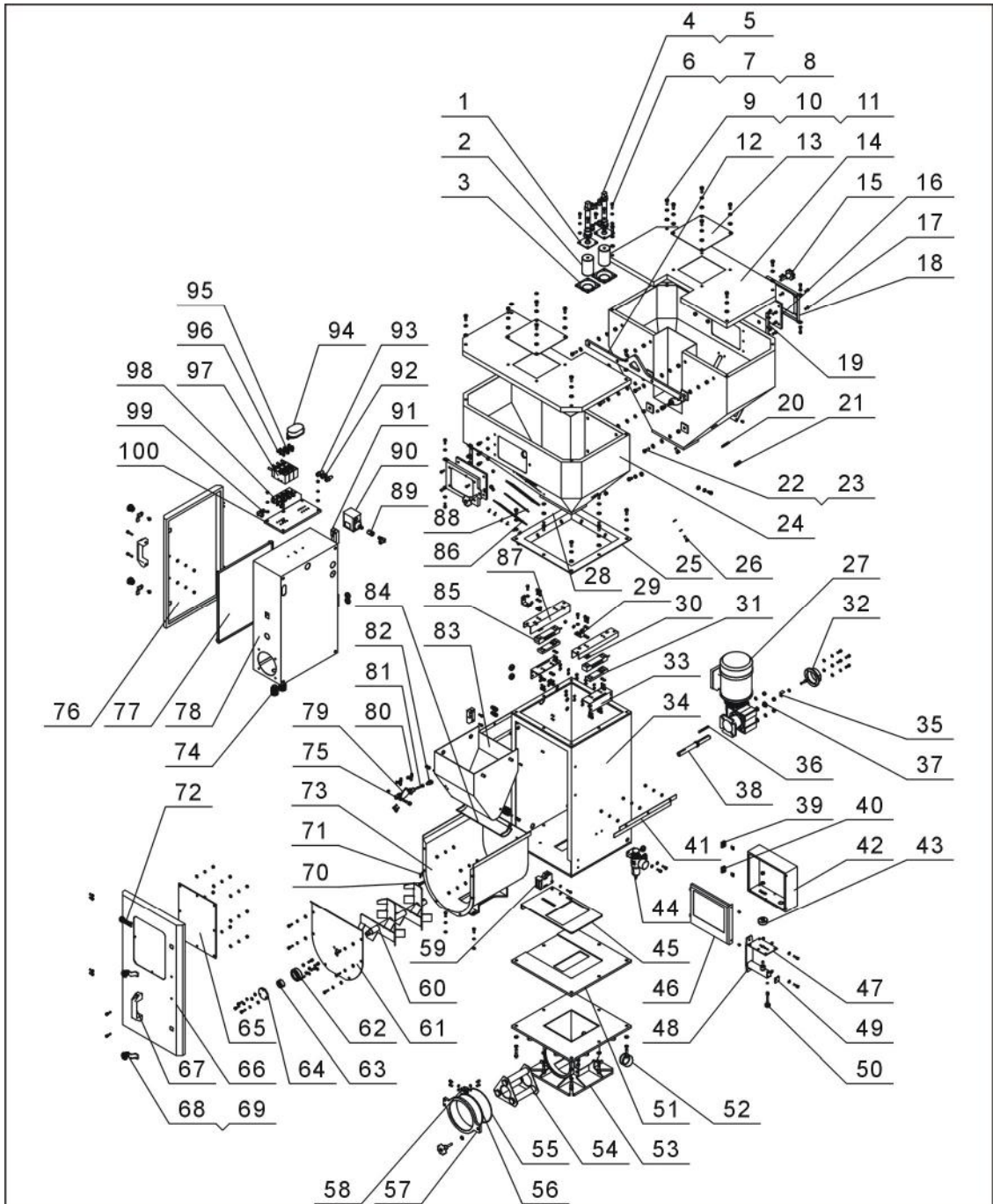

Remarks: Please refer to material List 2.2.8 for specific explanation of the Arabic numbers in parts drawing.

Picture 2-6: SGB-600-2 Assembly Drawing

2.2.8 SGB-600-2 Parts List

Table 2-4: Parts List (SGB-600-2)

No.	Name	Part No.	No.	Name	Part No.
1	Metering valve cylinder mounting plate	-	26	BoltM8×25	YW60082500200
2	Main metering valve welding	-	27	Gear motor	YM50257100200
3	Discharge port of main metering valve	-	28	Sight-glass packing (six holes)	YR40000600000
4	Air pipe quick coupling APL6-1/8	YW80061800200	29	Sensor protective linking block	-
5	Metering valve cylinder	YE31208000000	30	Gravimetric hopper supporting block washer	-
6	Socket head cap screw M6×20	YW61062000200	31	Sensor bearer	-
7	Spring washer 6	YW65006000100	32	Sense switch mounting plate welding	-
8	Flat washer 6	YW66061800000	33	Gravimetric hopper supporting plate	-
9	Bolt M8×20	YW60082000200	34	Rack welding	-
10	Spring washer 6	YW65008000100	35	Driven detector of mixing motor	-
11	Flat washer 8	YW66081600000	36	Flat key C6×6×60	BH10646000010
12	Hanger plate	-	37	Flat washer 8×22	YW66082200100
13	Square plate 200×200	YW09202000000	38	Mixing motor shaft	-
14	Hopper cover	-	39	Small hinge (right)	YW06203400000
15	Star knob B typeM8×35	YR40083500000	40	Small hinge (left)	YW06203400100
16	Clearance glass acryl	-	41	fender	-
17	Phillips screwM6×20	YW62062000000	42	Touch panel cabinet	-
18	Clearance glass door	-	43	Touch panel cabinet supporting block	-
19	Clearance glass supporting bars	-	44	Filter & pressure regulating valve	YE30421400000
20	material level sensor choke plug screwM30×1.5	YR30301500000	45	Shut-off plate at the bottom	-
21	material level sensor choke plug	BR30008400050	46	Touch panel cabinet cover	-
22	BoltM10×35	YW60103500100	47	Touch panel cabinet base plate	-
23	nutM10	YW60101050000	48	Touch panel support frame	-
24	Main hopper welding	-	49	Sprue	-
25	Hopper mounting plate	-	50	Bolt 组件	-

No.	Name	Part No.	No.	Name	Part No.
51	Shut-off plate at the bottom bearer	-	76	Control cabinet door plate	-
52	Discharge pipe cap	-	77	Electric elements mounting plate	-
53	Base welding	-	78	Control cabinet	
54	Hopper magnet	BY10340000050	79	Shut-off plate cylinder mounting block	-
55	Magnetic base spring	YW01040000000	80	Throttle valve	YW81050400000
56	Tempered glass400~600kg	YW70406000000	81	Shut-off plate cylinder	YE31162500000
57	Base door plate	-	82	Y TYPE PIN ROD	YE31001000000
58	Magnetic base hinge	BL01005020020	83	Gravimetric hopper welding	-
59	Inserted switch	YE16147600100	84	Gravimetric hopper shut-off plate welding	-
60	Paddle welding	-	85	gravimetric sensor	YE15001500000
61	Mixing tank cover	-	86	Sight-glass sheet iron (six holes)	YW09000600000
62	Bearing seat	-	87	Gravimetric hopper supporting plate	-
63	Bearing cover	YW09220200000	88	Acryl (six holes)	YR40001200000
64	Self aligning ball bearing	-	89	Barometric switch changeover nut	-
65	Door acryl	-	90	Barometric switch	YE90000800000
66	Door plate welding	-	91	Hinge (left)	YW06203100400
67	Aluminum square handle120L	BW20012000040	92	Air pipe quick coupling APC8-1/4	YW80081400000
68	Separation blade of door lock	YW00040600000	93	Copper muffler	YW80010400100
69	Short gate lock	YW00000600000	94	Alarm light	YE83305100300
70	Mixer shaft connecting key	-	95	Air pipe quick coupling APC6-1/8	YW80061800100
71	Socket head cap screwM3×15	YW61031500000	96	Air pipe quick coupling APL4-1/8	YW80041800000
72	Aluminum Shini trademark81×31 high stickiness	YP30813100100	97	Solenoid valve* -5-1/8-B	YE32051800100
73	Mixing tank welding	-	98	Junction platePRS-1/8-3	YW82180300000
74	Cable gland PG13.5	YE67013500000	99	Air pipe quick coupling APL8-1/4	YW80081400100
75	Shut-off plate cylinder screw	-	100	Pneumatic elements mounting plate	-

* means possible broken parts.

** means easy broken part. and spare backup is suggested.

Please confirm the version of manual before placing the purchase order to guarantee that the item number of the spare part is in accordance with the real object.

2.2.9 SGB-600-3 Assembly Drawing

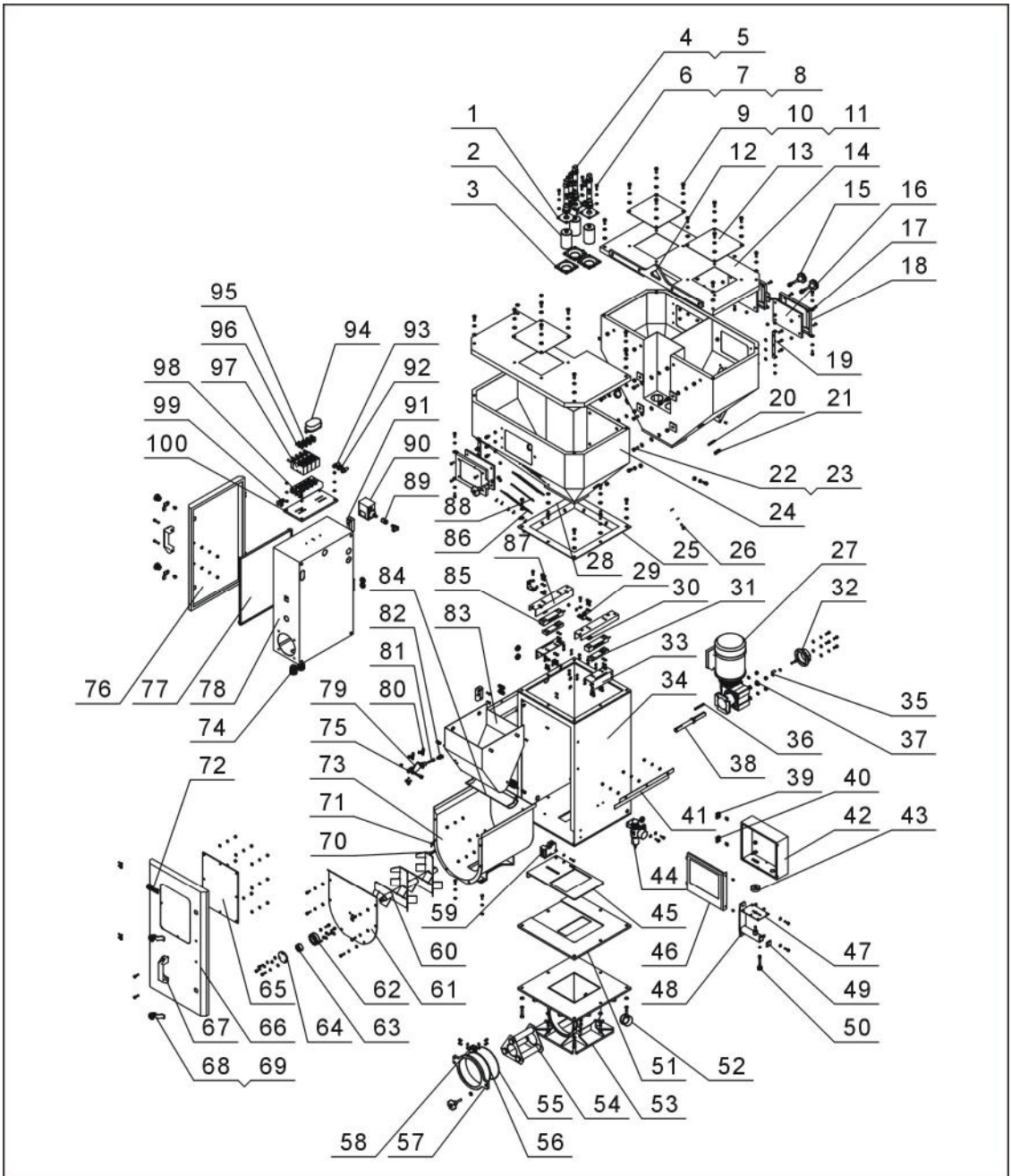

Remarks: Please refer to material List 2.2.10 for specific explanation of the Arabic numbers in parts drawing.

Picture 2-7: SGB-600-3 Assembly Drawing

2.2.10 SGB-600-3 Parts List

Table 2-5: Parts List (SGB600-3)

No.	Name	Part No.	No.	Name	Part No.
1	Metering valve cylinder mounting plate	-	26	Bolt M8×25	YW60082500200
2	Main metering valve welding	-	27	Gear motor	YM50257100200
3	Discharge port of main metering valve	-	28	Sight-glass packing (six holes)	YR40000600000
4	Air pipe quick coupling APL6-1/8	YW80061800200	29	Sensor protective linking block	-
5	Metering valve cylinder	YE31208000000	30	Gravimetric hopper supporting block washer	-
6	Socket head cap screw M6×20	YW61062000200	31	Sensor bearer	-
7	Spring washer 6	YW65006000100	32	Sense switch mounting plate welding	-
8	Flat washer 6	YW66061800000	33	Gravimetric hopper supporting plate	-
9	Bolt M8×20	YW60082000200	34	Rack welding	-
10	Spring washer 6	YW65008000100	35	Driven detector of mixing motor	-
11	Flat washer 8	YW66081600000	36	Flat key C6×6×60	BH10646000010
12	Hanger plate	-	37	Flat washer 8×22	YW66082200100
13	Square plate 200×200	YW09202000000	38	Mixing motor shaft	-
14	Hopper cover	-	39	Small hinge (right)	YW06203400000
15	Star knob B type M8×35	YR40083500000	40	Small hinge (left)	YW06203400100
16	Clearance glass acryl	-	41	fender	-
17	Phillips screw M6×20	YW62062000000	42	Touch panel cabinet	-
18	Clearance glass door	-	43	Touch panel cabinet supporting block	-
19	Clearance glass supporting bars	-	44	Filter & pressure regulating valve	YE30421400000
20	material level sensor choke plug screw M30×1.5	YR30301500000	45	Shut-off plate at the bottom	-
21	material level sensor choke plug	BR30008400050	46	Touch panel cabinet cover	-
22	Bolt M10×35	YW60103500100	47	Touch panel cabinet base plate	-
23	Nut M10	YW60101050000	48	Touch panel support frame	-
24	Main hopper welding	-	49	Sprue	-
25	Hopper mounting plate	-	50	Bolt	-

No.	Name	Part No.	No.	Name	Part No.
51	Shut-off plate at the bottom bearer	-	76	Control cabinet door plate	-
52	Discharge pipe cap	-	77	Electric elements mounting plate	-
53	Base welding	-	78	Control cabinet	
54	Hopper magnet	BY10340000050	79	Shut-off plate cylinder mounting block	-
55	Magnetic base spring	YW01040000000	80	Throttle valve	YW81050400000
56	Tempered glass400~600kg	YW70406000000	81	Shut-off plate cylinder	YE31162500000
57	Base door plate	-	82	Y TYPE PIN ROD	YE31001000000
58	Magnetic base hinge	BL01005020020	83	Gravimetric hopper welding	-
59	Inserted switch	YE16147600100	84	Gravimetric hopper shut-off plate welding	-
60	Paddle welding	-	85	gravimetric sensor	YE15001500000
61	Mixing tank cover	-	86	Sight-glass sheet iron (six holes)	YW09000600000
62	Bearing seat	-	87	Gravimetric hopper supporting plate	-
63	Bearing cover	YW09220200000	88	Acryl (six holes)	YR40001200000
64	Self aligning ball bearing	-	89	Barometric switch changeover nut	-
65	Door acryl	-	90	Barometric switch	YE90000800000
66	Door plate welding	-	91	Hinge (left)	YW06203100400
67	Aluminum square handle120L	BW20012000040	92	Air pipe quick couplingAPC8-1/4	YW80081400000
68	Separation blade of door lock	YW00040600000	93	Copper muffler	YW80010400100
69	Short gate lock	YW00000600000	94	Alarm light	YE83305100300
70	Mixer shaft connecting key	-	95	Air pipe quick couplingAPC6-1/8	YW80061800100
71	Socket head cap screwM3×15	YW61031500000	96	Air pipe quick couplingAPL4-1/8	YW80041800000
72	Aluminum Shini trademark81×31high stickiness	YP30813100100	97	Solenoid valve*-5-1/8-B	YE32051800100
73	Mixing tank welding	-	98	Junction platePRS-1/8-3	YW82180300000
74	Cable glandPG13.5	YE67013500000	99	Air pipe quick couplingAPL8-1/4	YW80081400100
75	Shut-off plate cylinder screw	-	100	Pneumatic elements mounting plate	-

* means possible broken parts.

** means easy broken part. and spare backup is suggested.

Please confirm the version of manual before placing the purchase order to guarantee that the item number of the spare part is in accordance with the real object.

2.2.11 SGB-600-4 Assembly Drawing

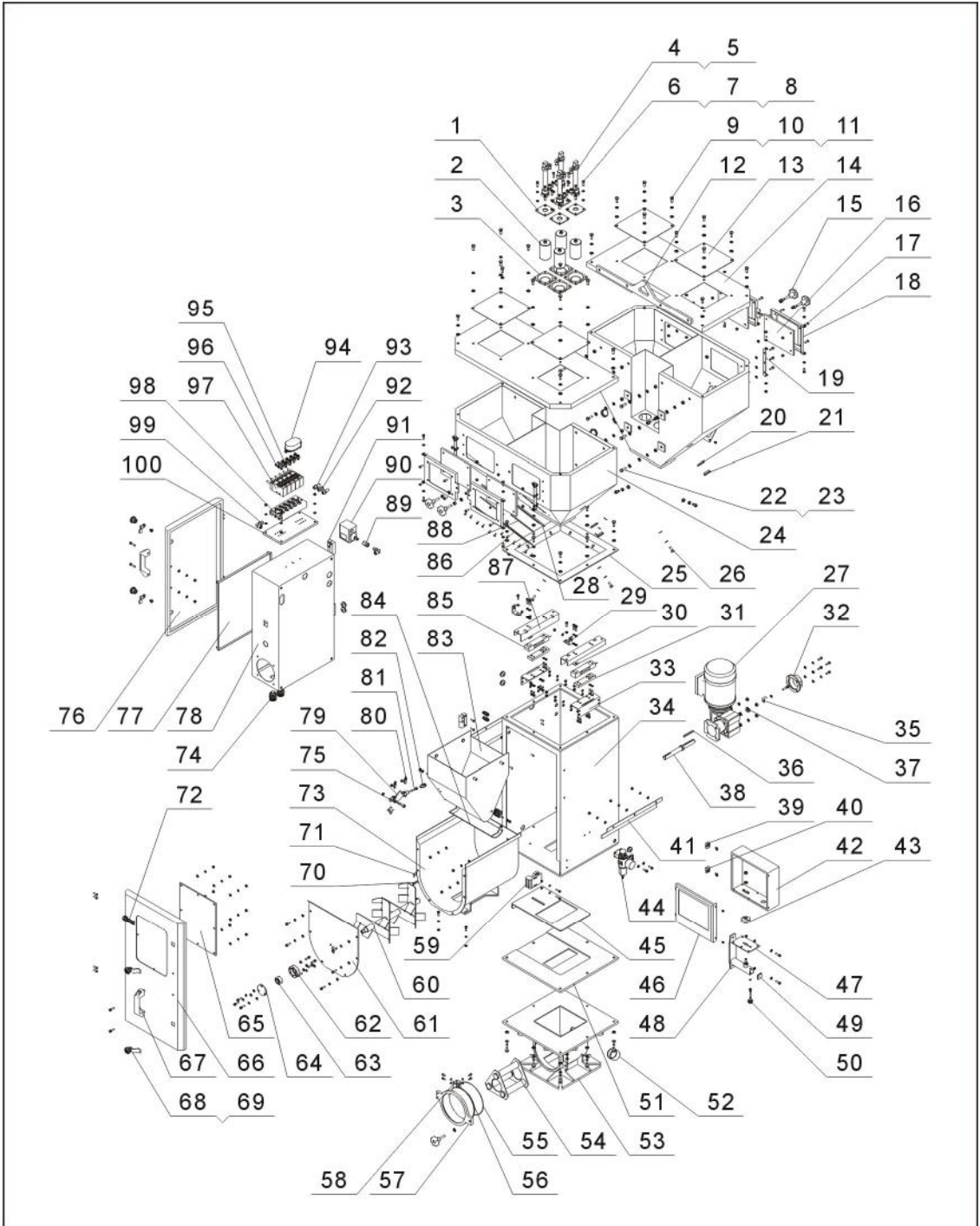

Remarks: Please refer to material List 2.2.12 for specific explanation of the Arabic numbers in parts drawing.

Picture 2-8: SGB-600-4 Assembly Drawing

2.2.12 SGB-600-4 Parts List

Table 2-6: Parts List (SGB600-4)

No.	Name	Part No.	No.	Name	Part No.
1	Metering valve cylinder mounting plate	-	26	BoltM8×25	YW60082500200
2	Main metering valve welding	-	27	Gear motor	YM50257100200
3	Discharge port of main metering valve	-	28	Sight-glass packing (six holes)	YR40000600000
4	Air pipe quick coupling APL6-1/8	YW80061800200	29	Sensor protective linking block	-
5	Metering valve cylinder	YE31208000000	30	Gravimetric hopper supporting block washer	-
6	Socket head cap screw M6×20	YW61062000200	31	Sensor bearer	-
7	Spring washer 6	YW65006000100	32	Sense switch mounting plate welding	-
8	Flat washer 6	YW66061800000	33	Gravimetric hopper supporting plate	-
9	Bolt M8×20	YW60082000200	34	Rack welding	-
10	Spring washer 8	YW65008000100	35	Driven detector of mixing motor	-
11	Flat washer 8	YW66081600000	36	Flat keyC6×6×60	BH10646000010
12	Hanger plate	-	37	Flat washer8×22	YW66082200100
13	Square plate 200×200	YW09202000000	38	Mixing motor shaft	-
14	Hopper cover	-	39	Small hinge (right)	YW06203400000
15	Star knob B type M8×35	YR40083500000	40	Small hinge (left)	YW06203400100
16	Clearance glass acryl	-	41	fender	-
17	Phillips screw M6×20	YW62062000000	42	Touch panel cabinet	-
18	Clearance glass door	-	43	Touch panel cabinet supporting block	-
19	Clearance glass supporting bars	-	44	Filter & pressure regulating valve	YE30421400000
20	material level sensor choke plug screwM30×1.5	YR30301500000	45	Shut-off plate at the bottom	-
21	material level sensor choke plug	BR30008400050	46	Touch panel cabinet cover	-
22	Bolt M10×35	YW60103500100	47	Touch panel cabinet base plate	-
23	Nut M10	YW60101050000	48	Touch panel support frame	-
24	Main hopper welding	-	49	Sprue	-
25	Hopper mounting plate	-	50	Bolt	-

No.	Name	Part No.	No.	Name	Part No.
51	Shut-off plate at the bottom bearer	-	76	Control cabinet door plate	-
52	Discharge pipe cap	-	77	Electric elements mounting plate	-
53	Base welding	-	78	Control cabinet	
54	Hopper magnet	BY10340000050	79	Shut-off plate cylinder mounting block	-
55	Magnetic base spring	YW01040000000	80	Throttle valve	YW81050400000
56	Tempered glass 400~600kg	YW70406000000	81	Shut-off plate cylinder	YE31162500000
57	Base door plate	-	82	Y type pin rod	YE31001000000
58	Magnetic base hinge	BL01005020020	83	Gravimetric hopper welding	-
59	Inserted switch	YE16147600100	84	Gravimetric hopper shut-off plate welding	-
60	Paddle welding	-	85	gravimetric sensor	YE15001500000
61	Mixing tank cover	-	86	Sight-glass sheet iron (six holes)	YW09000600000
62	Bearing seat	-	87	Gravimetric hopper supporting plate	-
63	Bearing cover	YW09220200000	88	Acryl (six holes)	YR40001200000
64	Self aligning ball bearing	-	89	Barometric switch changeover nut	-
65	Door acryl	-	90	Barometric switch	YE90000800000
66	Door plate welding	-	91	Hinge (left)	YW06203100400
67	Aluminum square handle 120L	BW20012000040	92	Air pipe quick coupling APC8-1/4	YW80081400000
68	Separation blade of door lock	YW00040600000	93	Copper muffler	YW80010400100
69	Short gate lock	YW00000600000	94	Alarm light	YE83305100300
70	Mixer shaft connecting key	-	95	Air pipe quick coupling APC6-1/8	YW80061800100
71	Socket head cap screw M3×15	YW61031500000	96	Air pipe quick coupling APL4-1/8	YW80041800000
72	Aluminum Shini trademark81×31high stickiness	YP30813100100	97	Solenoid valve* -5-1/8-B	YE32051800100
73	Mixing tank welding	-	98	Junction plate PRS-1/8-5	YW82180500000
74	Cable gland PG13.5	YE67013500000	99	Air pipe quick couplingAPL8-1/4	YW80081400100
75	Shut-off plate cylinder screw	-	100	Pneumatic elements mounting plate	-

* means possible broken parts.

** means easy broken part. and spare backup is suggested.

Please confirm the version of manual before placing the purchase order to guarantee that the item number of the spare part is in accordance with the real object.

2.2.13 SGB-2000-4 Assembly Drawing

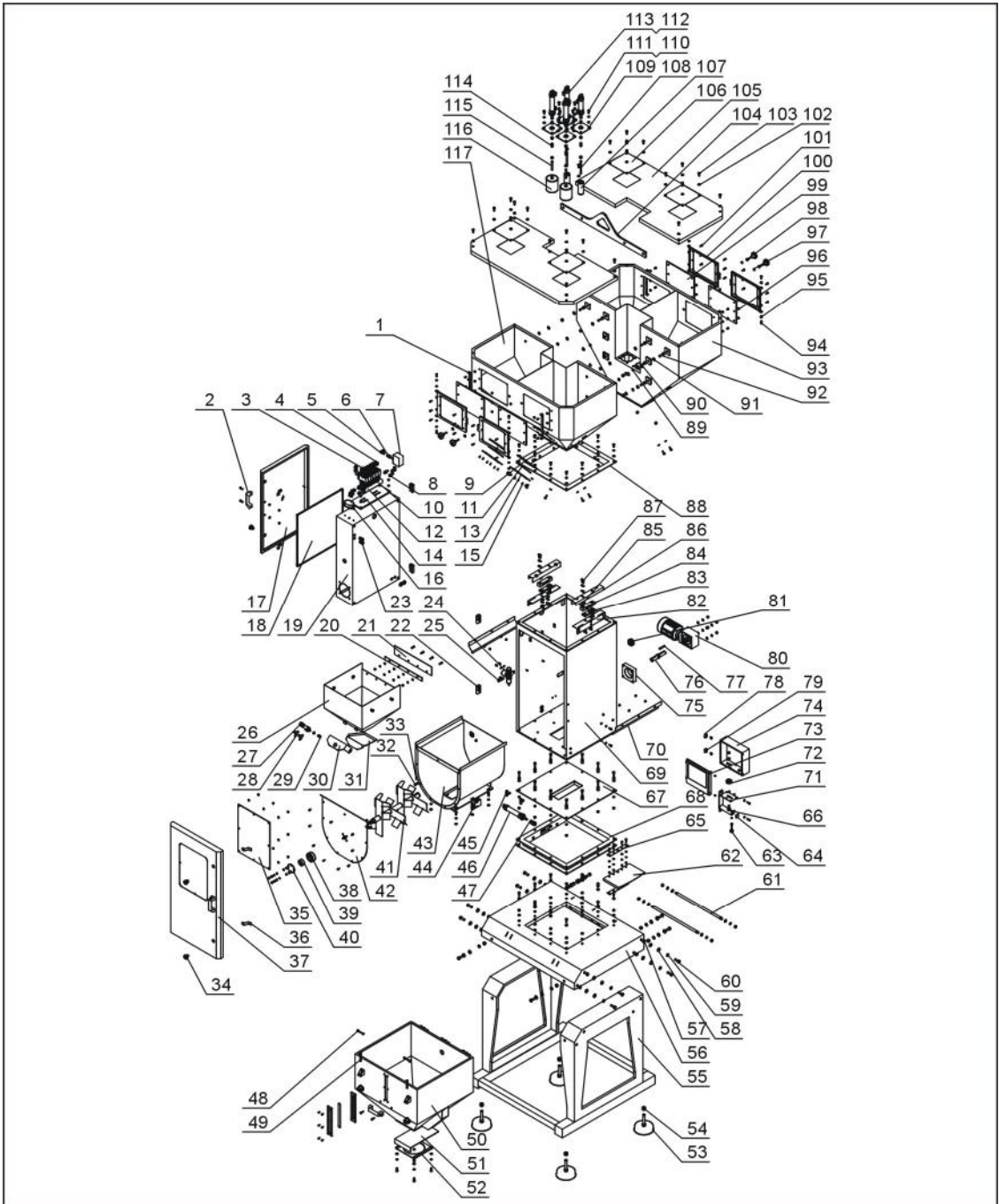

Remarks: Please refer to material List 2.2.14 for specific explanation of the Arabic numbers in parts drawing.

Picture 2-9: SGB-2000-4 Assembly Drawing

2.2.14 SGB-2000-4 Parts List

Table 2-7: Parts List (SGB-2000-4)

No.	Name	Part No.	No.	Name	Part No.
1	Clearance glass supporting bars	-	25	Air pipe quick coupling SPD8-1/4	YW80801400000
2	Aluminum handle(M6 孔)	BW20012000040	26	Gravimetric hopper welding	-
3	Air pipe quick coupling APL-6-1/8	YW80061800200	27	Cylinder DSNU-20-25-P-A	YE31205000000
4	Air pipe quick coupling APL-6-1/8	YW80061800100	28	Speed regulating connector Φ6-1/8	YW80061800300
5	Air pipe quick coupling APL-8-1/4	YW80081400100	29	Weighing copper head	-
6	Barometric switch changeover nut	-	30	Shut-off plate supporting block	-
7	Low pressure switch controller (0~8kg)	YE90000800000	31	Shut-off plate welding	-
8	Muffler 1/4"(M/S2)	YW80010400000	32	Socket head cap screw M4×10	YW61041001100
9	Sight-glass packing (six holes)	YR40000600000	33	Mixer shaft key	-
10	Solenoid valve* MFH-5-1/8-B	YE32051800100	34	Short gate lock	YW00006000000
11	Acryl (six holes)	YR40001200000	35	Front door acryl	-
12	Junction plate PRS-1/8-6BBT	YW82180600000	36	Separation blade of door lock	YW00040600000
13	Sight-glass sheet iron (six holes)	YW09000600000	37	Front door welding	-
14	Solenoid valve mounting plate	-	38	Bearing seat	-
15	Cross recess head screw M5×10	YW62051000000	39	Bearing 2204E-2RS1TN9	YW11220400000
16	Alarm light	YE83305100300	40	Bearing cap	-
17	Electric cabinet door	-	41	Paddle welding	-
18	Electric mounting plate	-	42	Mixing tank cover	-
19	Electric cabinet	-	43	Mixing tank welding	-
20	Fender trim strip	-	44	Inserted switch	YE16147600100
21	Material fender	-	45	Speed regulating connector Φ6-1/8	YW80061800300
22	Big hinge (left)	YW06203100400	46	Cylinder DSNU-32-100-P-A	YE31321000000
23	Plate type air pipe coupling QSS-6	YW80000600000	47	Y type pin rod SG-M10×1.25	YE31001000000
24	Filter & pressure regulating valve	YE30421400000	48	Socket head cap screw M8-60	YW60086000100

No.	Name	Part No.	No.	Name	Part No.
49	Star bolt 5/16	YW09051600100	78	Small hinge (right)	YW06203400000
50	Storage tank welding	-	79	Small hinge (left)	YW06203400100
51	Storage tank shut-off plate	-	80	Gear motor RNYM05-1220-30	YM10512200000
52	Storage tank base plate	-	81	Material level sprue	-
53	Shock eliminator (M16×20)	YW03162000000	82	Sensor supporting plate	-
54	Hex nut M16	YW64004600200	83	Sensor bearer	-
55	Floor stand welding	-	84	gravimetric sensor15kg	YE15001500000
56	Floor stand cover welding	-	85	Gravimetric hopper supporting block washer	-
57	nutM12	YW64001600000	86	Gravimetric hopper supporting block	-
58	Flat washer12	YW66122400000	87	Socket head cap screwM6×20	YW61062000300
59	Spring washer12	YW65012000000	88	Hopper fixing plate	-
60	BoltM12×5	YW60123500000	89	Spring washer10	YW65010000000
61	Discharge valve guide	-	90	Hex nut M10	YW64001000200
62	Discharge valve shut-off plate	-	91	Flat washer10	YW66102000100
63	Bolt	-	92	BoltM10×35	YW60103500100
64	Sprue	-	93	Hooper welding	-
65	Shut-off plate bearer	-	94	Socket head cap screw M6×16	YW61061600300
66	Touch panel cabinet supporting frame	-	95	Flat washer 6	YW66061300000
67	Discharge valve cover welding	-	96	Hex nut M6	YW64000600200
68	Pneumatic discharge valve welding	-	97	Hex nut M8	YW60082010000
69	Rack welding	-	98	Star knob B typeM×35	YR40083500000
70	Mixing tank material fender	-	99	Clearance glass acryl	-
71	Touch panel cabinet base plate	-	100	Clearance glass door	-
72	Touch panel cabinet supporting block	-	101	Cross recess head screwM6×15	YW62061500000
73	Touch panel cabinet cover	-	102	Flat washer	YW66081600000
74	Touch panel cabinet	-	103	BoltM8×20	YW60082000300
75	Mixing motor bearer	-	104	Hanger plate	-
76	Mixing motor shaft	-	105	Hopper cover	-
77	Flat key C8×55	-	106	Square plate 200×200	YW09202000000

No.	Name	Part No.	No.	Name	Part No.
107	Second discharge valve welding	-	113	Air pipe quick coupling APL-6-1/8	YW80061800200
108	Second discharge valve connecting screw	-	114	Discharge valve connecting nut	-
109	Discharge valve cylinder mounting plate	-	115	Main discharge valve connecting rod	-
110	Socket head cap screw M8×16	YW61081600200	116	Main discharge welding	-
111	Spring washer 8	YW65008000000	117	Hopper welding	-
112	Cylinder DSNU-32-60-P-A	YE31326010000			

* means possible broken parts.

** means easy broken part. and spare backup is suggested.

Please confirm the version of manual before placing the purchase order to guarantee that the item number of the spare part is in accordance with the real object.

2.2.15 Assembly of Floor Stand

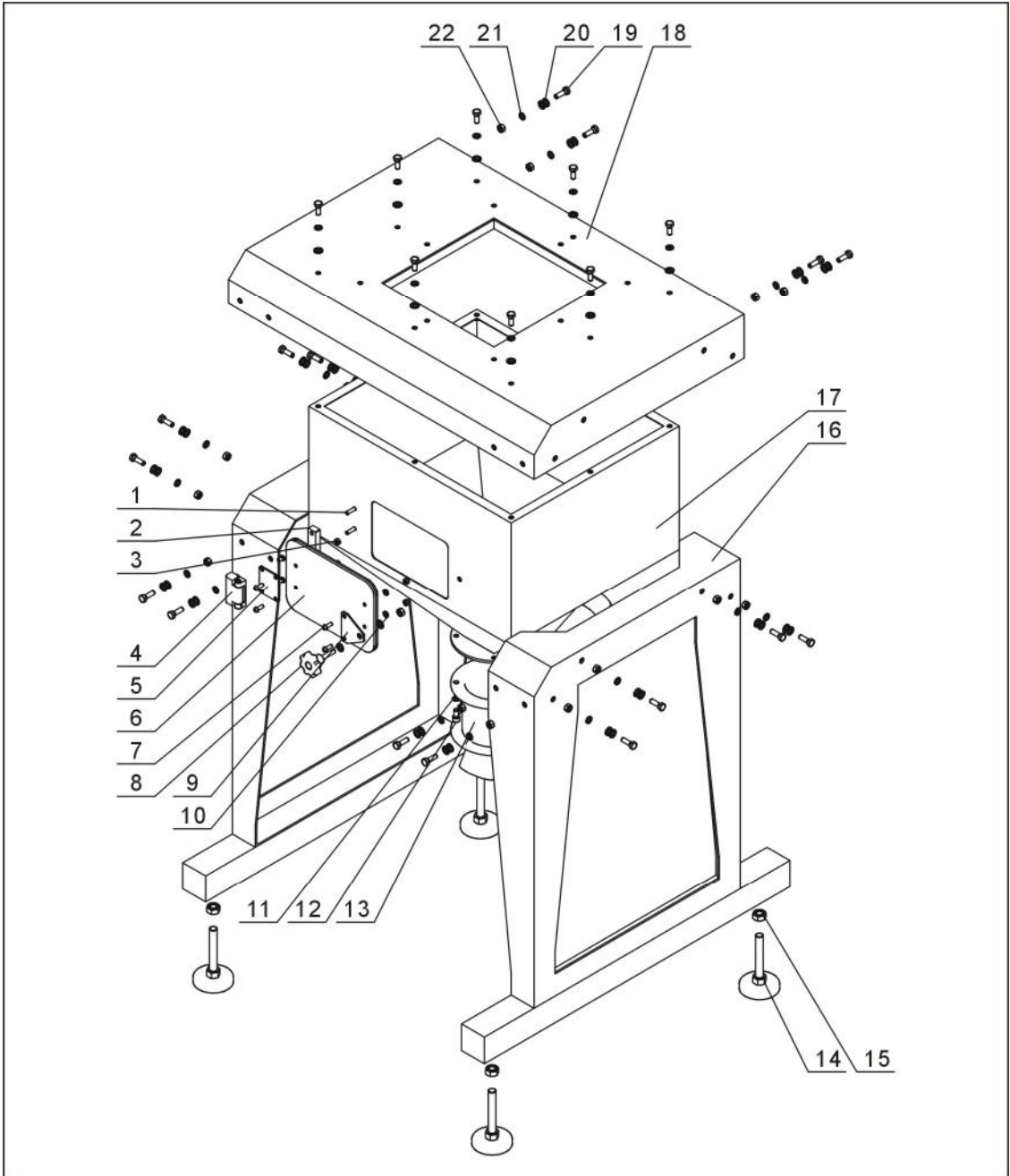

Remarks: Please refer to material List 2.2.16 for specific explanation of the Arabic numbers in parts drawing.

Picture 2-10: Assembly of Floor Stand

2.2.16 Assembly of Floor Stand Parts List

Table 2-8: Assembly of Floor Stand Parts List

No.	Name	Part No.	
		SGB-200	SGB-600
1	Socket head cap screw M6×25	YW61062500000	YW61062500000
2	Storage hopper hinge bearer	-	-
3	Nut M6	YW64000600100	YW64000600100
4	Big hinge CL219-1	YW06219100000	YW06219100000
5	Square linking block	-	-
6	Clearance glass acryl	-	-
7	Cross recess head screwM6×15	YW62061500000	YW62061500000
8	Star knob B typeM8×35	YR40083500000	YR40083500000
9	Triangle linking block	-	-
10	Flat washer6	YW66061200000	YW66061200000
11	Spring washer6	YW65006000100	YW65006000100
12	Socket head cap screwM6×16	YW61061600300	YW61061600300
13	European type suction box SBU-20-38S	BY10203801150	BY10203801150
14	Shock eliminator M14×75	YW03147500000	YW03147500000
15	Hex nut M14	YW64001400200	YW64001400200
16	Floor stand welding	-	-
17	Storage tank welding	-	-
18	Floor stand cover welding	-	-
19	BoltM8×25	YW60082500200	YW60082500200
20	Flat washer8	YW66081600000	YW66081600000
21	Spring washer8	YW65008000100	YW65008000100
22	Hex nut M8	YW64000800300	YW64000800300

* means possible broken parts.

** means easy broken part. and spare backup is suggested.

Please confirm the version of manual before placing the purchase order to guarantee that the item number of the spare part is in accordance with the real object.

2.2.17 Pneumatic Discharge Valve Assembly

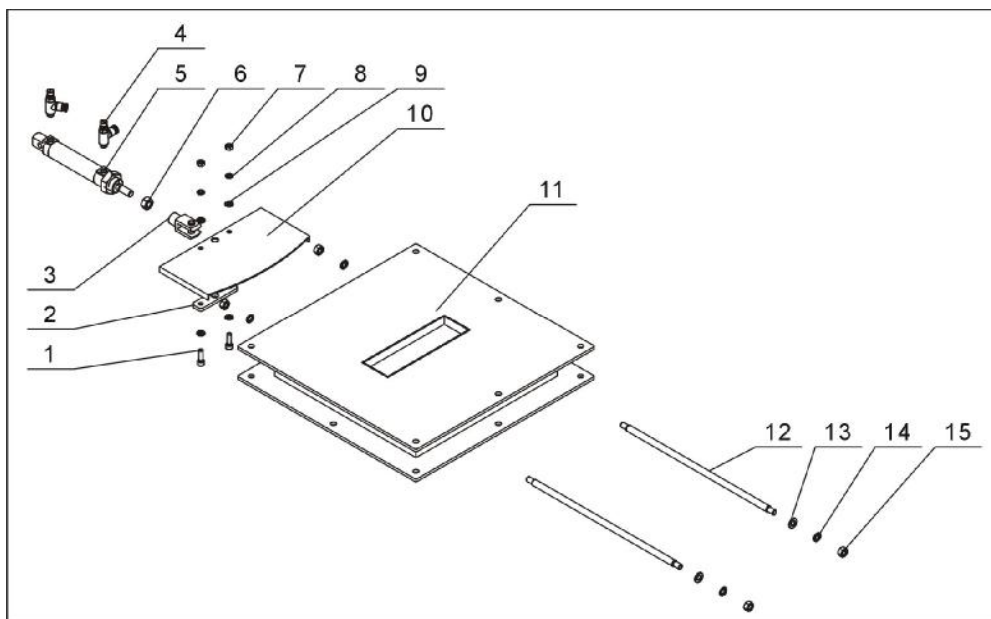

Picture 2-11: Pneumatic Discharge Valve Assembly Drawing

2.2.18 Parts List of Pneumatic Discharge Valve

Table 2-9: Parts List of Pneumatic Discharge Valve

No.	Name	Part No.	
		SGB-200	SGB-600
1	Socket head cap screwM6*20	YW61062000000	YW61062000000
2	Discharge plate bearer	-	-
3	Y type pin rodsg-M10*1.25	YE31001000000	YE31001000000
4	Speed regulating connector 1/8-ø6	YW80061800300	YW80061800300
5	Cylinder* DSNU-25-60-P-A	YE31256010000	YE31256010000
6	Hex nut M10*1.25	YW64101200400	YW64101200400
7	Hex nut M6	YW64000600100	YW64000600100
8	Spring washer6	YW65006000000	YW65006000000
9	Flat washer6	YW66061300000	YW66061300000
10	Shut-off plate guide rod	-	-
11	Pneumatic discharge valve welding	-	-
12	Shut-off plate guide rod	-	-
13	Flat washer8	YW66081600000	YW66081600000
14	Spring washer8	YW65008000100	YW65008000100
15	Hex nut M8	YW61000800200	YW61000800200

* means possible broken parts. ** means easy broken part. and spare backup is suggested. Please confirm the version of manual before placing the purchase order to guarantee that the item number of the spare part is in accordance with the real object.