

2.2 Assembly Drawing

2.2.1 Assembly Drawing (SAL-1HP/2HP-UG122)

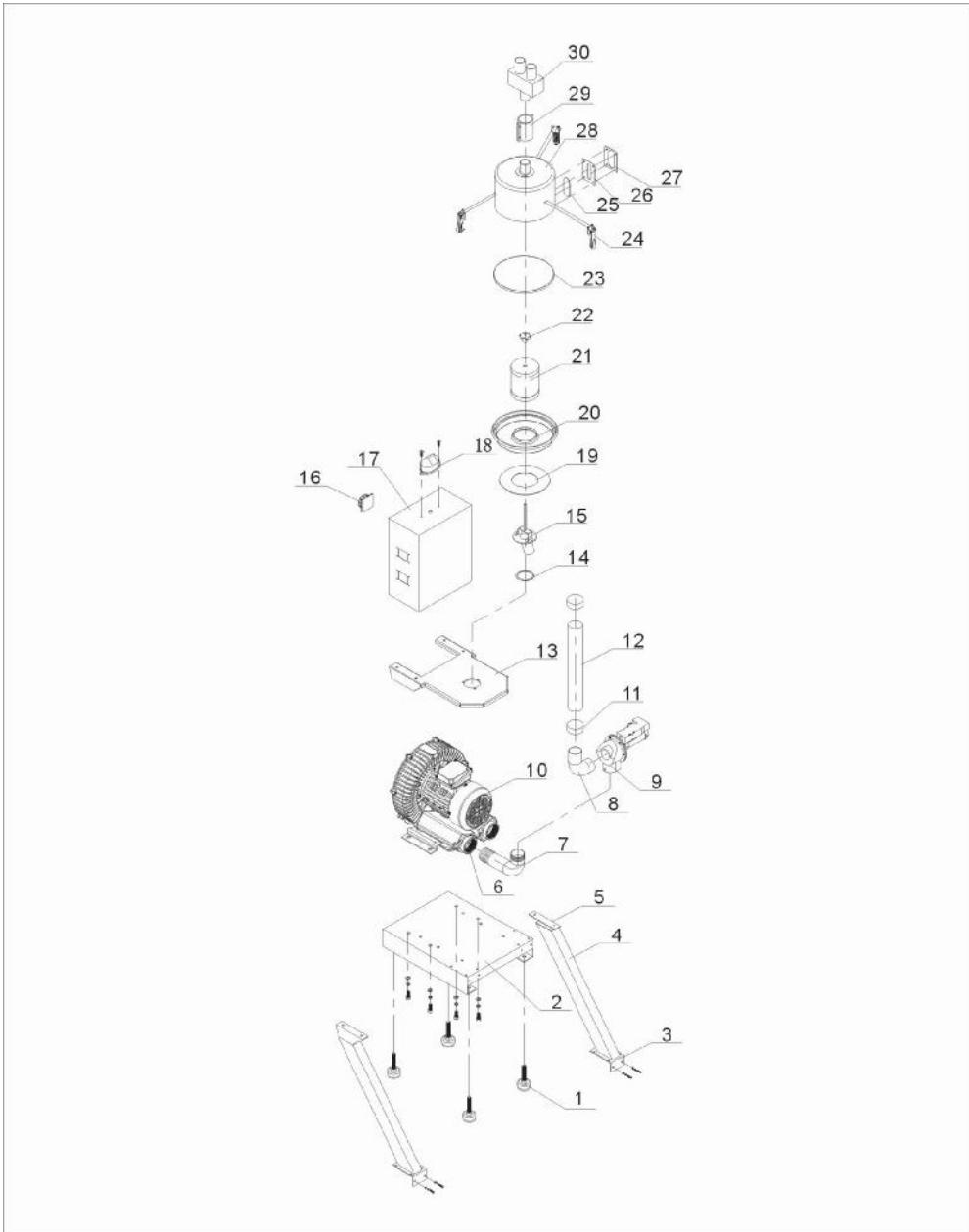

Remarks: Please refer to material list 2.2.2 for specific explanation of the Arabic numbers in parts drawing.

Picture 2-2: Assembly Drawing (SAL-1HP/2HP-UG122)

2.2.2 Parts List (SAL-1HP/2HP-UG122)

Table 2-1: Parts List (SAL-1HP/2HP-UG122)

No.	Name	Part No.	No.	Name	Part No.
1	Anti-vibration pad	YW03005000000	16	Controller holder	YE10200300000
2	Base	-	17	Main switch*	BH32012040050
3	Lower welding block on column	-	18	Alarm light	YE83305100200
4	Standing post	-	19	Filter barrel lid barrel	YR10030000000
5	Upper welding block on column	-	20	Filter barrel lid	-
6	Blower flange	-	21	Air filter*	YR50708000000
7	Air inlet pipe	-	22	Star nut	YW69051600000
8	Diaphragm valve connection pipe	-	23	Filter container seal ring*	YR10708000100
9	Vacuum breaking diaphragm valve	BY20015000050	24	Spring clip*	YW02003000400
10	High pressure pipe 1HP	BM30031000150	25	Acryl	BH32070000050
	High pressure pipe 2HP	BM30042000050	26	Seal ring	YR40000400000
11	Clip	YW02000200000	27	Iron sheet of 4-hole sight glass	YW09000000400
12	Steel wired plastic pipe	YR60157000000	28	Filter barrel	-
13	Filter fixing bracket	-	29	Pipe connector	YW20001500800
14	Filter barrel base fastener	-	30	Three-way valve	-
15	Filter barrel lid assembly	-			

* means possible broken parts.

** means easy broken part. and spare backup is suggested.

Please confirm the version of manual before placing the purchase order to guarantee that the item number of the spare part is in accordance with the real object.

2.2.3 Assembly Drawing (SAL-3.5HP/5HP(-D)-122)

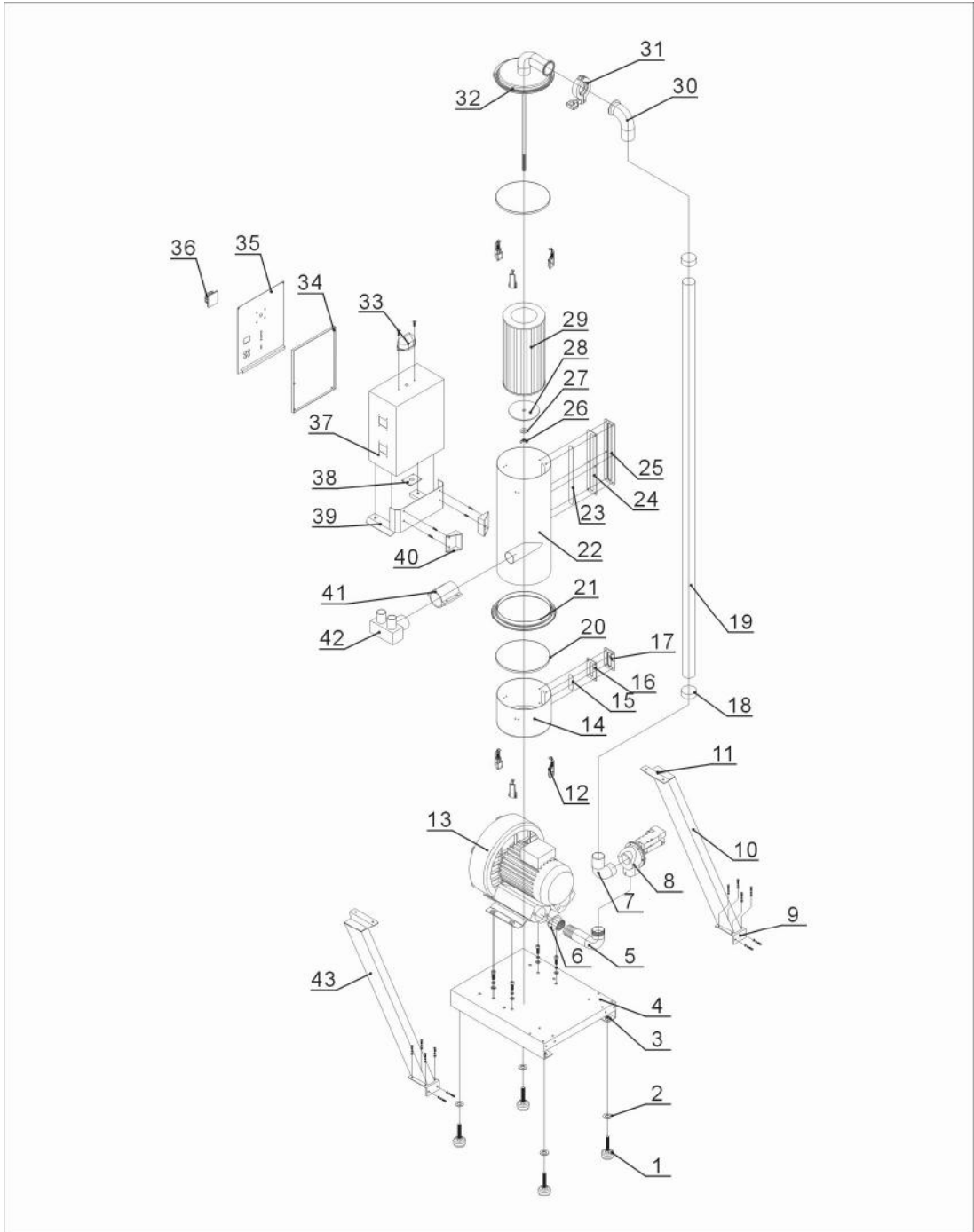

Remarks: Please refer to material list 2.2.4 for specific explanation of the Arabic numbers in parts drawing.

Picture 2-3: Assembly Drawing (SAL-3.5HP/5HP(-D)-UG122)

2.2.4 Parts List (SAL-3.5HP/5HP (-D)-UG122)

Table 2-2: Parts List (SAL-3.5HP/5HP (-D)-UG122)

No.	Name	Part No.	No.	Name	Part No.
1	Anti-vibration pad Φ50	YW03005000000	22	Filter barrel assembly	-
2	Filter barrel lid 8	YW66082200100	23	Acryl	YR40001200000
3	Nut M12	YW64012100000	24	Seal ring	YR40000600000
4	Base	BL21003500120	25	Iron sheet of 4-hole sight glass	YW09000600000
5	Air inlet fastener	BL26003506520-	26	Butterfly nut 5/16"	YW69051600000
6	Blower flange	-	27	Filter fixing plate 8	YW66082200100
7	Vacuum breaking diaphragm valve 1.5"	BY20015000050	28	Stator	BL26003502520
8	Vacuum breaking diaphragm valve pipe connector	BL26003505720	29	Air filter ADC2	YR50181100000
9	Standing post lower welded block	-	30	Air suction pipe	-
10	Right standing column	BL26003506620	31	Coupling clip	YW07000200000
11	Standing post top welded block	-	32	Filter barrel lid assembly	-
12	Spring clip*	YW02003000400	33	Alarm light Lte-3051 ac220v	YE83305100200
13	High pressure pipe 3.5HP	BM30053500050	34	Control base board	-
	High pressure pipe 5HP	BM30055000050	35	Cover board	-
	High pressure pipe 5HP double stage	YM30433700000	36	Main power switch	YE10210300000
14	Dust collection bin	BL26003507021	37	Control box	-
15	Acryl	BH32070000050	38	Fixing plate	-
16	Seal ring	YR40000400000	39	Fixing plate	-
17	Iron sheet of 4-hole Sight glass	YW09000000400	40	Control cabinet mounting plate	-
18	Clip 2.5"	YW02002500000	41	Pipe connector	YW20002000700
19	Steel wired plastic Pipe 2"	YR60205000100	42	Three-way valve	-
20	Dust collecting barrel Seal ring*	YR10708000100	43	Left standing pole	BL26003506620
21	Filter container ring	BL19003500120			

* means possible broken parts.

** means easy broken part. and spare backup is suggested.

Please confirm the version of manual before placing the purchase order to guarantee that the item number of the spare part is in accordance with the real object.

2.2.5 Assembly Drawing (SAL-7.5HP/10HP (-D)-UG122)

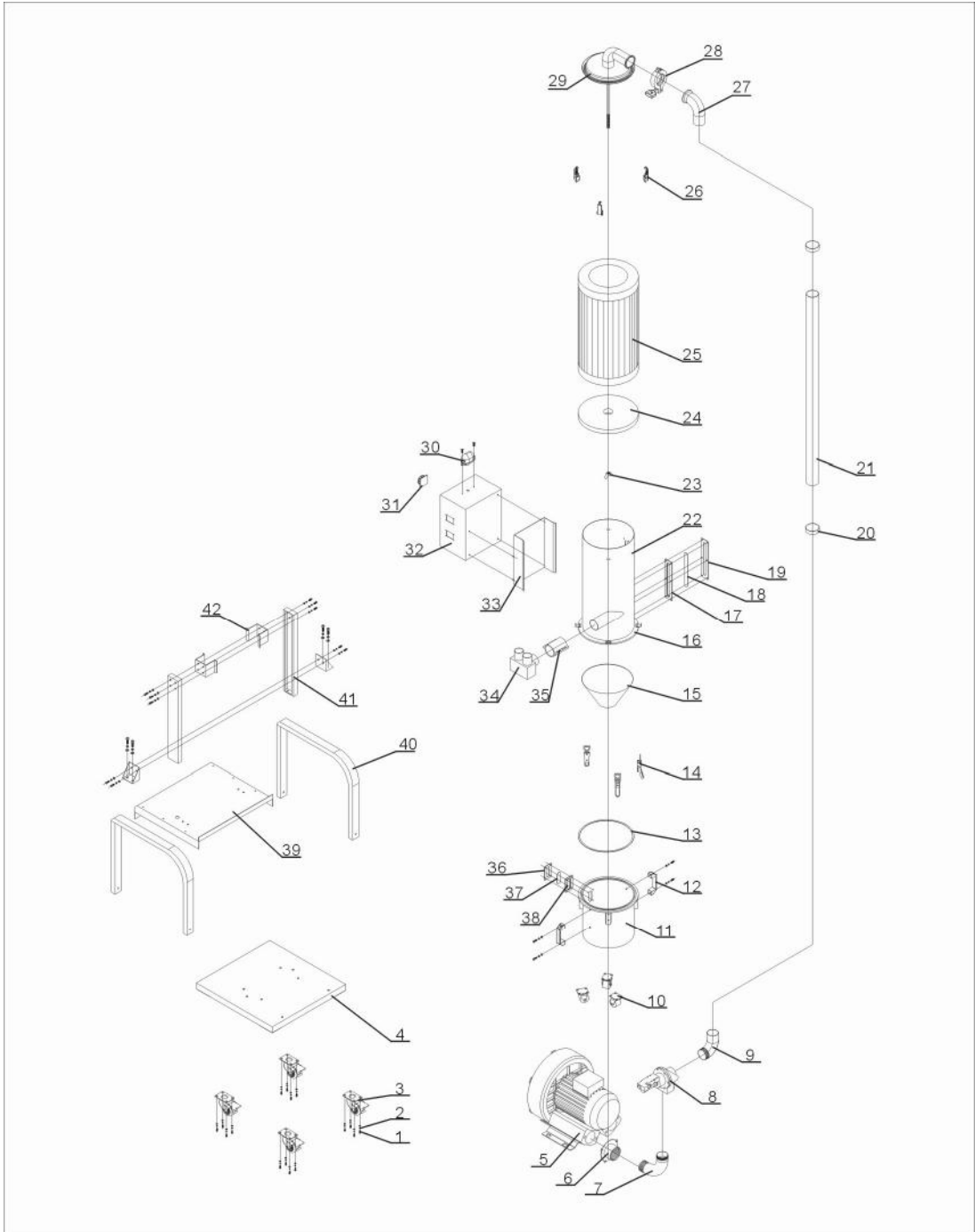

Remarks: Please refer to material list 2.2.6 for specific explanation of the Arabic numbers in parts drawing.

Picture 2-4: Assembly Drawing (SAL-7.5HP/10HP (-D)-UG122)

2.2.6 Parts List (SAL-7.5HP/10HP (-D)-UG122)

Table 2-3: Parts List (SAL-7.5HP/10HP (-D)-UG122)

No.	Name	Part No.	No.	Name	Part No.
1	Hex. head screw	YW60084000200	20	Clip	YW02002500000
2	Spring washer	YW66081600000	21	Steel wire hose	YR60002500000
3	3" movable castor	YW03000300200	22	Filter barrel assembly	-
	3" castor with brake	YW03000300000	23	Butterfly nut	YW69051600000
4	Base	BL26007502721	24	Filter fixing plate	BL26007504720
5	High pressure blower 7.5HP	BM30075000050	25	Air filter*	YR50221400000
	High pressure blower 7.5HP double stage	YM30635500000	26	Spring clip*	YW02003000400
	High pressure blower 10HP	BM30081000050	27	Filter barrel lid assembly	-
	High pressure blower 10HP double stage	YM30637500000	28	2.5" coupling clip	YW07002500600
6	Blower flange	-	29	Filter barrel lid assembly	-
7	Air inlet fastener	BL26007504920	30	Alarm light	YE83305100200
8	Pneumatic diaphragm valve	BY20020000150	31	Main switch	YE10210300000
9	Pneumatic valve coupling	BL26007502020	32	Control box	BH32007500550
10	Castor	YW03002500000	33	Control cabinet mounting plate	-
11	Dust collecting barrel	BL26007502421	34	Connection pipe	BH80002510050
12	Aluminium handle	BW20012000040	35	Three way	-
13	Dust collecting barrel seal ring*	-	36	Iron sheet of 4-hole sight glass	YW09000000400
14	Large handle	YW02003000100	37	Acryl	BH32070000050
15	Cyclone baffle	-	38	4-holes window seal ring	YR40000400000
16	Bottom ring of filter barrel	-	39	Middle plate	-
17	6-holes window seal ring	YR40000600000	40	Supporting frame 1	-
18	Acryl	YR40001200000	41	Pillar of filter barrel	-
19	Iron sheet of 6-hole sight glass	YW09000600000	42	Filtering barrel fixation block	-

* means possible broken parts.

** means easy broken part. and spare backup is suggested.

Please confirm the version of manual before placing the purchase order to guarantee that the item number of the spare part is in accordance with the real object.