

## 1. 电路图参数表(SDL-300U~1200U 230V)

符号/SYMBOL 型号/MODE	(a)	(b)	(c1)	(c2)	(c3)	(d)	(e)	(f)	(g)	(h)	(i)	(j)	(k)	(l)	(m)	(n)	(o)	(p)
SDL-200U	4.0	25	10	6	16	1.5	0.28-0.4	0.33	0.05	0.3	1.5	5.5-8	7.0	1.5	6.3	2.5	2.2	5.5
SDL-400U	4.0	25	10	6	16	1.5	0.7-1	0.8	0.12	0.75	1.5	5.5-8	7.0	1.5	6.3	2.5	3.0	7.5
SDL-800U	4.0	25	16	6	16	1.5	0.7-1	0.8	0.12	0.75	1.5	5.5-8	7.0	1.5	6.3	2.5	3.9	9.8
SDL-1200U	4.0	25	16	6	16	1.5	0.7-1	0.8	0.12	0.75	1.5	5.5-8	7.0	1.5	6.3	2.5	3.9	9.8
SDL-1600U	4.0	25	20	6	16	1.5	0.7-1	0.8	0.12	0.75	1.5	5.5-8	7.0	1.5	6.3	2.5	6.0	15
SDL-2300U	6.0	25	20	6	16	1.5	0.7-1	0.8	0.12	0.75	1.5	5.5-8	7.0	1.5	6.3	2.5	6.0	15
SDL-3000U	10	63	40	6	16	1.5	1.1-1.6	1.3	0.18	1.1	1.5	5.5-8	7.0	1.5	6.3	6.0	12.0	30
SDL-4500U	10	63	40	6	16	1.5	1.1-1.6	1.3	0.18	1.1	1.5	5.5-8	7.0	1.5	6.3	6.0	12.0	30
SDL-6000U	16	60	60	6	16	1.5	2.2-3.2	2.5	0.55	2.3	1.5	5.5-8	7.0	1.5	6.3	16	18.0	45
SDL-7500U	16	60	60	6	16	1.5	2.2-3.2	2.5	0.55	2.3	1.5	5.5-8	7.0	1.5	6.3	16	18.0	45
SDL-9000U	25	90	80	6	20	1.5	2.2-3.2	2.5	0.55	2.3	2.5	9-12.5	11	2.4	10.2	16	18.0	45
SDL-12000U	25	90	80	10	20	1.5	3.5-5	4.5	1.1	4.2	2.5	9-12.5	11	2.4	10.2	6.0	12*2	30x2

- (a) 主电源线径      (b) 主电源开关      (c1) 电热断路器      (c2) 风车断路器      (d) 干燥风车线径  
 (e) 干燥风车负载器      (f) 干燥风车负载器设定      (g) 干燥风车功率      (h) 干燥风车电流      (i) 吸料风车线径  
 (j) 吸料风车负载器      (k) 吸料风车负载器设定      (l) 吸料风车功率      (m) 吸料风车电流      (n) 电热线径  
 (o) 电热功率      (p) 电热电流

## 2. 主电路图(SDL-300U~1200U 230V)

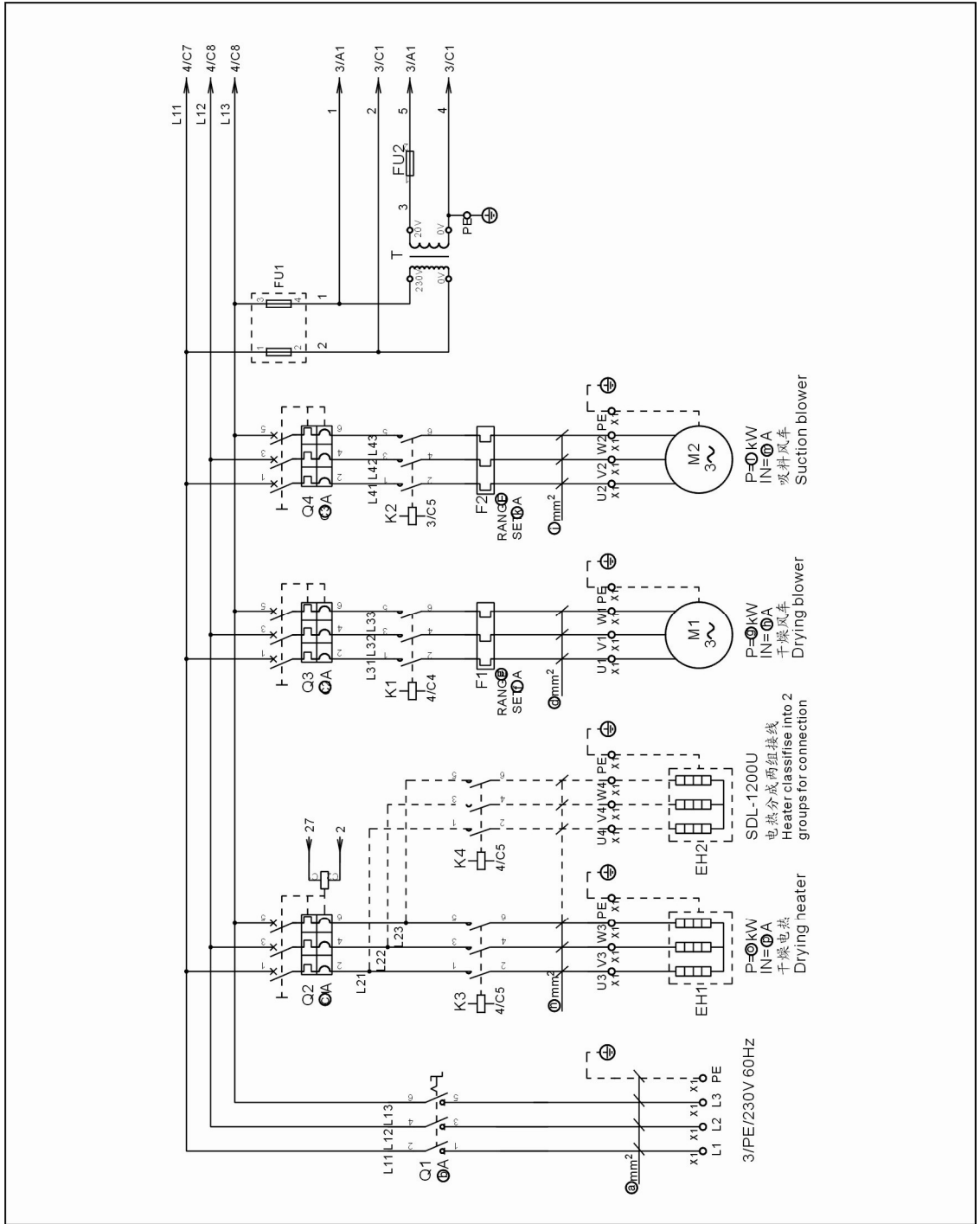

### 3. 控制电路图一(SDL-300U~1200U 230V)

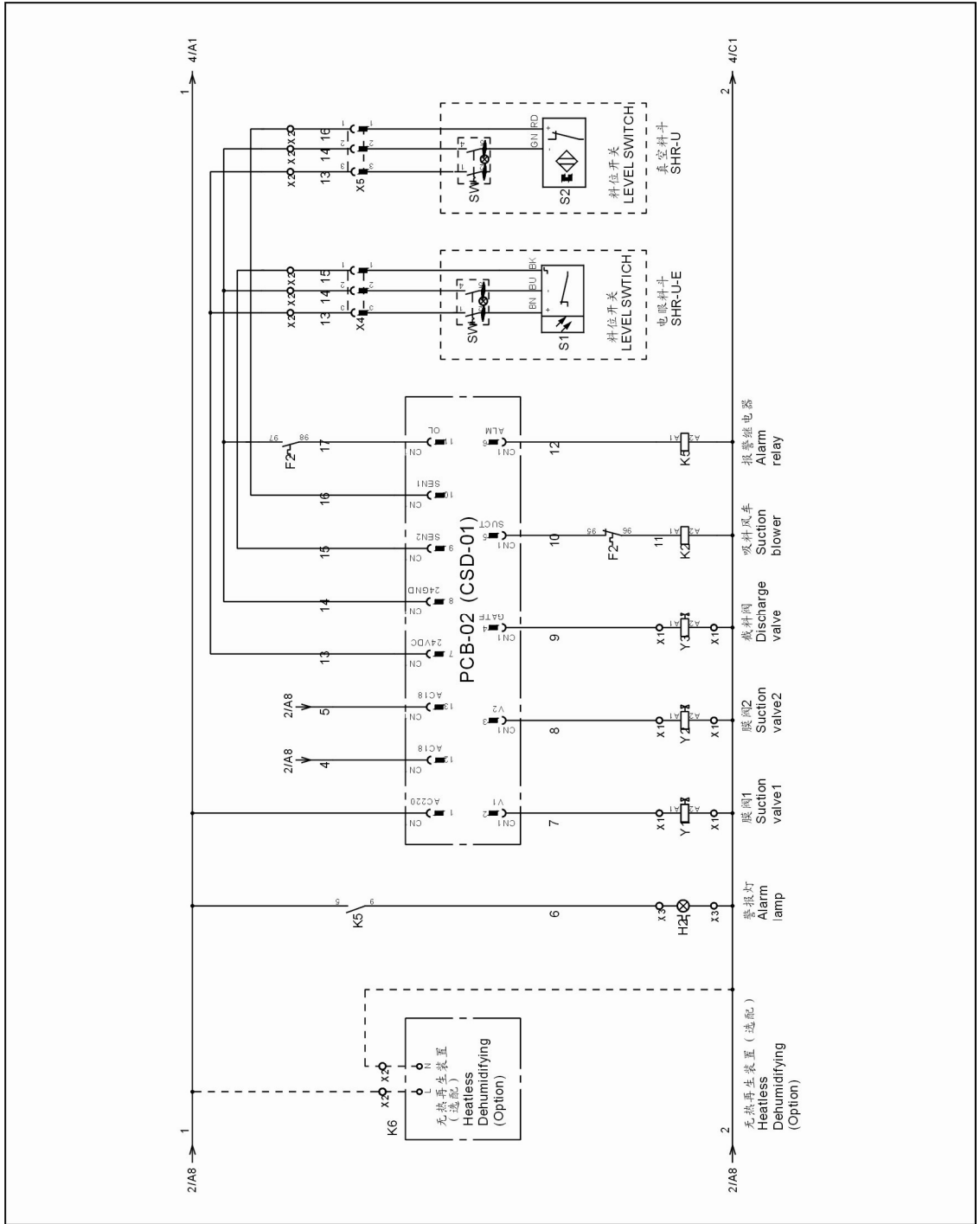

#### 4. 控制电路图二(SDL-300U~1200U 230V)

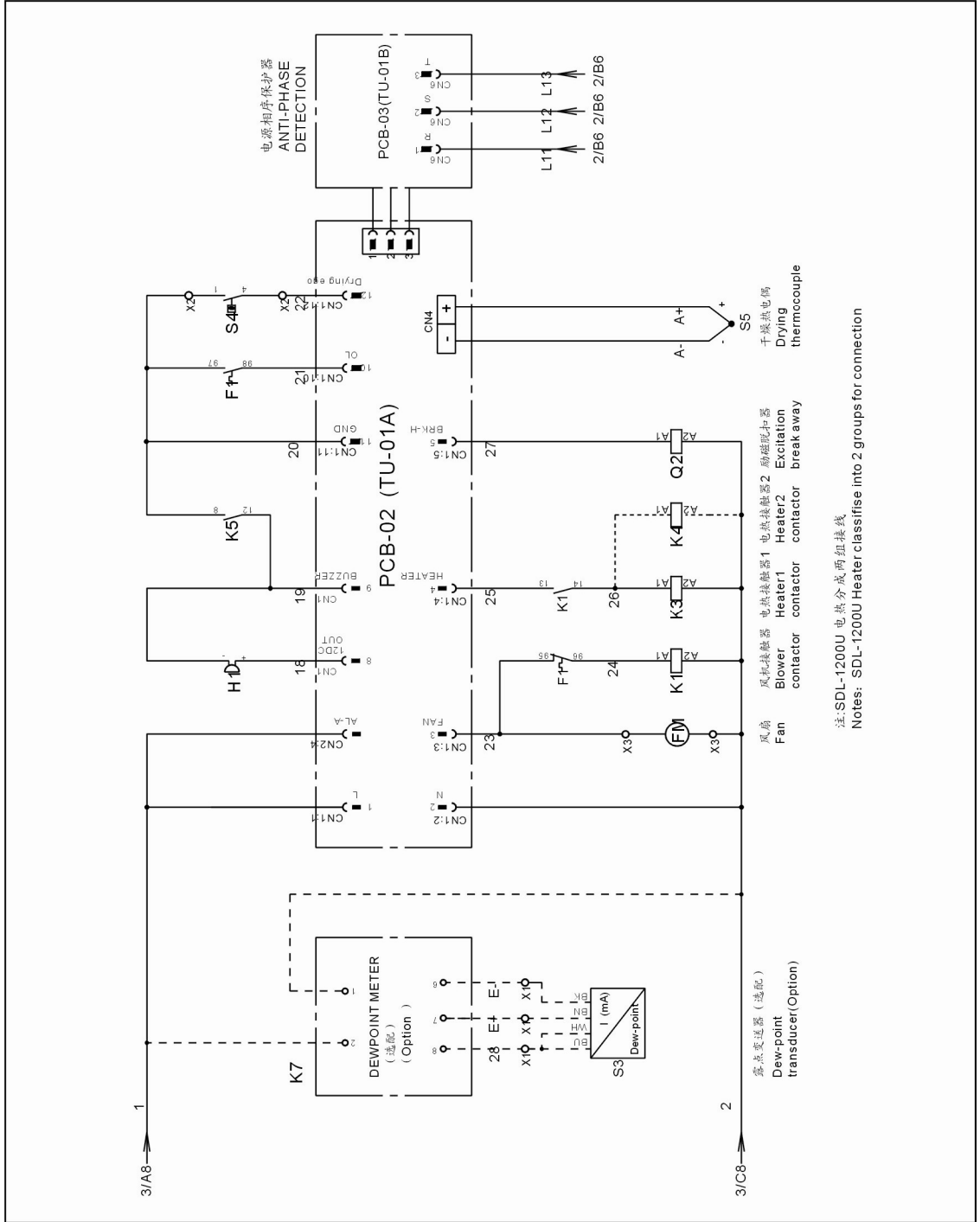

## 5. 电气元件布置图(SDL-300U~1200U 230V)

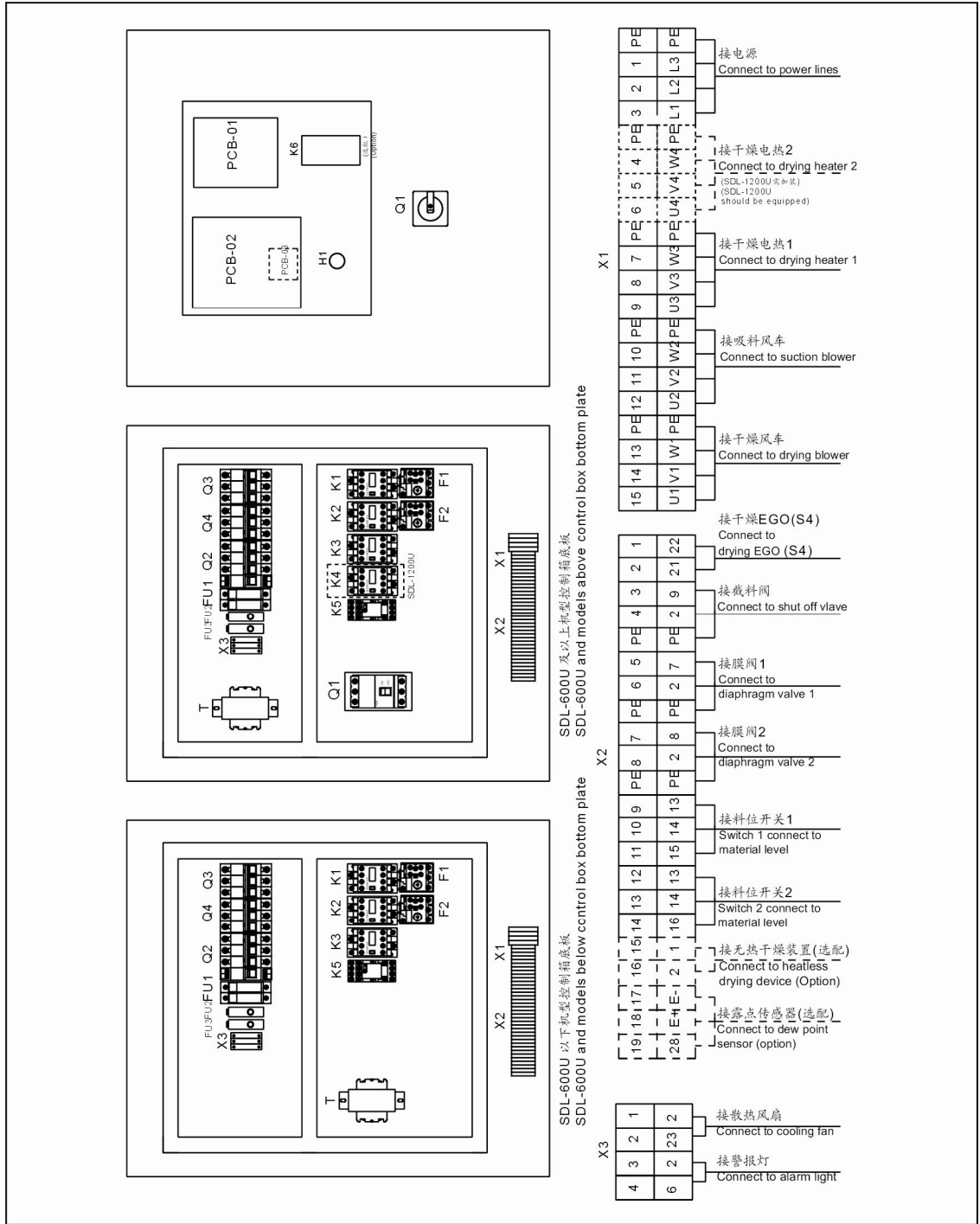

## 6. 电气组件明细表(SDL-300U/450U 230V)

序号	符号	名称	SDL-300U/450U	
			规格	物料编号
1	Q1	主电源开关	63A	YE10250400000
2	Q2	断路器*	40A	YE40604000000
3	-	励磁脱扣器	230VAC 50/60Hz	YE40023560000
4	Q3	断路器*	5A	YE40603000000
5	Q4	断路器*	15A	YE40601500000
6	K1	接触器*	220V 50/60Hz	YE00601521000
7	K2	接触器*	220V 50/60Hz	YE00601621000
8	K3	接触器*	220V 50/60Hz	YE00602822000
9	K5	中间继电器*	230V 50/60Hz 12A	YE03270700000
10	K6	无热再生装置	230V 50/60Hz	-
11	K7	露点计表	230V 50/60Hz	YE85122000100
12	T	互感变压器*	IN=230V OUT=230/20V 500mA	YE70202300400
13	F1	热过载继电器*	1.1~1.6A	YE01160110000
14	F2	热过载继电器*	5.5~8A	YE01160550000
15	FU1	熔断器座**	2P	YE41032200000
16	-	熔断器芯	2A	YE46002000000
17	FU2	熔断器**	-	YE46002000000
18	-	熔芯	0.5A	YE46630500000
19	S3	露点变送器	POWER=24VDC OUT=4-20mA	YE10041100000
20	S4	温度保护器*	115-320°	BH90115000150
21	S5	热电偶	K	BE90802000050
22	PCB-01	微电脑控制板*	V1.1 18VAC	YE80101100000
23	PCB-02	微电脑控制板*	230VAC 50/60Hz	YE80001100000
24	PCB-03	微电脑控制板	-	YE80001100100
25	H1	蜂鸣器	3-24VDC	YE84002700000
26	H2	警报指示灯	230VAC 50Hz	YE83305100200
27	FM	风扇	230VAC 40W	YM60121200400
28	Y1 Y2 Y3	电磁阀*	230VAC 50/60Hz	YE32051800300
29	M1	风车*	230V 50/60Hz 0.18kW	-
30	M2	风车*	230V 50/60Hz 1.5kW	-
31	EH1	电热管**	230V 50/60Hz 12kW	-
32	X1	端子排	-	YE61250040000
33	-	-	-	YE61253500000
34	-	-	-	YE61060000000
35	-	-	-	YE61063500000
36	-	-	-	YE61100000000
37	-	-	-	YE61103500000
38	X2	端子排	-	YE61250040000
39	-	-	-	YE61253500000

40	-	-	-	YE61250040000
41	-	-	-	YE61250040000
42	X3	端子排	-	YE61250040000
43	X4 X5	重载接头	4P 10A	YE68041000100

\*表示可能损坏的项目；\*\*表示较可能损坏的项目，建议备份。

请在下单采购零配件之前，先确认说明书版本号，以确保零配件物料号与实物一致。

## 7. 电气组件明细表(SDL-600U/750U 230V)

序号	符号	名称	SDL-600U/750U	
			规格	物料编号
1	Q1	主电源开关	60A	YE41106200000
2	Q2	断路器*	60A	YE40606000000
3	-	励磁脱扣器	230VAC 50/60Hz	YE40023560000
4	Q3	断路器*	5A	YE40603000000
5	Q4	断路器*	15A	YE40601500000
6	K1	接触器*	220V 50/60Hz	YE00601521000
7	K2	接触器*	220V 50/60Hz	YE00601621000
8	K3	接触器*	220V 50/60Hz	YE00504400000
9	K5	中间继电器*	230V 50/60Hz 12A	YE03270700000
10	K6	无热再生装置	230V 50/60Hz	-
11	K7	露点计表	230V 50/60Hz	YE85122000100
12	T	互感变压器*	IN=230V OUT=230/20V 500mA	YE70202300400
13	F1	热过载继电器*	2.2-3.2A	YE01160220000
14	F2	热过载继电器*	5.5~8A	YE01160550000
15	FU1	熔断器座**	2P	YE41032200000
16	-	熔断器芯	2A	YE46002000000
17	FU2	熔断器**	-	YE46002000000
18	-	熔芯	0.5A	YE46630500000
19	S3	露点变送器	POWER=24VDC OUT=4-20mA	YE10041100000
20	S4	温度保护器*	115-320°	BH90115000150
21	S5	热电偶	K	BE90802000050
22	PCB-01	微电脑控制板*	V1.1 18VAC	YE80101100000
23	PCB-02	微电脑控制板*	230VAC 50/60Hz	YE80001100000
24	PCB-03	微电脑控制板	-	YE80001100100
25	H1	蜂鸣器	3-24VDC	YE84002700000
26	H2	警报指示灯	230VAC 50Hz	YE83305100200
27	FM	风扇	230VAC 40W	YM60121200400
28	Y1 Y2 Y3	电磁阀*	230VAC 50/60Hz	YE32051800300
29	M1	风车*	230V 50/60Hz 0.55kW	-
30	M2	风车*	230V 50/60Hz 1.5kW	-
31	EH1	电热管**	230V 50/60Hz 18kW	-
32	X1	端子排	-	YE61250040000
33	-	-	-	YE61253500000
34	-	-	-	YE61160000000
35	-	-	-	YE61163500000
36	X2	端子排	-	YE61250040000
37	-	-	-	YE61253500000
38	-	-	-	YE61250040000
39	-	-	-	YE61250040000



40	X3	端子排	-	YE61250040000
41	X4 X5	重载接头	4P 10A	YE68041000100

\*表示可能损坏的项目；\*\*表示较可能损坏的项目，建议备份。

请在下单采购零配件之前，先确认说明书版本号，以确保零配件物料号与实物一致。

## 8. 电气组件明细表(SDL-900U 230V)

序号	符号	名称	SDL-900U	
			规格	物料编号
1	Q1	主电源开关	90A	YE41109200000
2	Q2	断路器*	80A	YE40800300000
3	-	励磁脱扣器	230VAC 50/60Hz	YE40023560000
4	Q3	断路器*	5A	YE40603000000
5	Q4	断路器*	20A	YE40602000000
6	K1	接触器*	220V 50/60Hz	YE00601521000
7	K2	接触器*	220V 50/60Hz	YE00601721000
8	K3	接触器*	220V 50/60Hz	YE00504400000
9	K5	中间继电器*	230V 50/60Hz 12A	YE03270700000
10	K6	无热再生装置	230V 50/60Hz	-
11	K7	露点计表	230V 50/60Hz	YE85122000100
12	T	互感变压器*	IN=230V OUT=230/20V 500mA	YE70202300400
13	F1	热过载继电器*	2.2-3.2A	YE01160220000
14	F2	热过载继电器*	9-12.5A	YE01169125000
15	FU1	熔断器座**	2P	YE41032200000
16	-	熔断器芯	2A	YE46002000000
17	FU2	熔断器**	-	YE46002000000
18	-	熔芯	0.5A	YE46630500000
19	S3	露点变送器	POWER=24VDC OUT=4-20mA	YE10041100000
20	S4	温度保护器*	115-320°	BH90115000150
21	S5	热电偶	K	BE90802000050
22	PCB-01	微电脑控制板*	V1.1 18VAC	YE80101100000
23	PCB-02	微电脑控制板*	-	YE80001100000
24	PCB-03	微电脑控制板	-	YE80001100100
25	H1	蜂鸣器	3-24VDC	YE84002700000
26	H2	警报指示灯	230VAC 50Hz	YE83305100200
27	FM	风扇	230VAC 40W	YM60121200400
28	Y1 Y2 Y3	电磁阀*	230VAC 50/60Hz	YE32051800300
29	M1	风车*	230V 50/60Hz 0.55kW	-
30	M2	风车*	230V 50/60Hz 2.4kW	-
31	EH1	电热管**	230V 50/60Hz 18kW	-
32	X1	端子排	-	YE61250040000
33	-	-	-	YE61253500000
34	-	-	-	YE61160000000
35	-	-	-	YE61163500000
36	-	-	-	YE61025000000
37	-	-	-	YE61025000100
38	X2	端子排	-	YE61250040000
39	-	-	-	YE61253500000

40	-	-	-	YE61250040000
41	-	-	-	YE61250040000
42	X3	端子排	-	YE61250040000
43	X4 X5	重载接头	4P 10A	YE68041000100

\*表示可能损坏的项目；\*\*表示较可能损坏的项目，建议备份。

请在下单采购零配件之前，先确认说明书版本号，以确保零配件物料号与实物一致。

## 9. 电气组件明细表(SDL-1200U 230V)

序号	符号	名称	SDL-1200U	
			规格	物料编号
1	Q1	主电源开关	90A	YE41109200000
2	Q2	断路器*	80A	YE40800300000
3	-	励磁脱扣器	230VAC 50/60Hz	YE40023560000
4	Q3	断路器*	10A	YE40600300000
5	Q4	断路器*	20A	YE40602000000
6	K1	接触器*	220V 50/60Hz	YE00601521000
7	K2	接触器*	220V 50/60Hz	YE00601721000
8	K3	接触器*	220V 50/60Hz	YE00602822000
9	K5	中间继电器*	230V 50/60Hz 12A	YE03270700000
10	K6	无热再生装置	230V 50/60Hz	-
11	K7	露点计表	230V 50/60Hz	YE85122000100
12	T	互感变压器*	IN=230V OUT=230/20V 500mA	YE70202300400
13	F1	热过载继电器*	3.5-5A	YE01160350000
14	F2	热过载继电器*	9-12.5A	YE01169125000
15	FU1	熔断器座**	2P	YE41032200000
16	-	熔断器芯	2A	YE46002000000
17	FU2	熔断器**	-	YE46002000000
18	-	熔芯	0.5A	YE46630500000
19	S3	露点变送器	POWER=24VDC OUT=4-20mA	YE10041100000
20	S4	温度保护器*	115-320°	BH90115000150
21	S5	热电偶	K	BE90802000050
22	PCB-01	微电脑控制板*	V1.1 18VAC	YE80101100000
23	PCB-02	微电脑控制板*	-	YE80001100000
24	PCB-03	微电脑控制板	-	YE80001100100
25	H1	蜂鸣器	3-24VDC	YE84002700000
26	H2	警报指示灯	230VAC 50Hz	YE83305100200
27	FM	风扇	230VAC 40W	YM60121200400
28	Y1 Y2 Y3	电磁阀*	230VAC 50/60Hz	YE32051800300
29	M1	风车*	230V 50/60Hz 0.55kW	-
30	M2	风车*	230V 50/60Hz 2.4kW	-
31	EH1	电热管**	230V 50/60Hz 12kW	-
32	X1	端子排	-	YE61250040000
33	-	-	-	YE61253500000
34	-	-	-	YE61060000000
35	-	-	-	YE61063500000
36	-	-	-	YE61025000000
37	-	-	-	YE61025000100
38	X2	端子排	-	YE61250040000
39	-	-	-	YE61253500000

40	-	-	-	YE61250040000
41	-	-	-	YE61250040000
42	X3	端子排	-	YE61250040000
43	X4 X5	重载接头	4P 10A	YE68041000100

\*表示可能损坏的项目；\*\*表示较可能损坏的项目，建议备份。

请在下单采购零配件之前，先确认说明书版本号，以确保零配件物料号与实物一致。