

# **SG-23/30**

## **Sound-proof Central Granulator**

Date: Aug., 2022

Version: Ver.F (English)





## Contents

<b>1. General Description .....</b>	<b>7</b>
1.1 Coding Principle.....	8
1.2 Feature .....	8
1.3 Safety Regulations.....	10
1.3.1 Safety signs and labels.....	10
1.3.2 Transportation and Storage of the Machine .....	12
1.3.3 Rejected parts disposal .....	13
1.4 Exemption Clause.....	13
<b>2. Structural Features and Working Principle.....</b>	<b>14</b>
2.1 General Description .....	14
2.1.1 Working Principle.....	14
2.2 Safety System.....	15
2.2.1 Emergency Stop.....	15
2.2.2 Safety Switch.....	15
2.2.3 Star Screw.....	16
2.3 Electrical Components Instruction.....	17
2.3.1 Microprocessor Board (PCB).....	17
2.3.2 Electrical Components in Electrical Components box .....	18
2.4 Optional Accessories .....	19
2.4.1 Full-receiver Alarm Device .....	19
2.4.2 Feed Hopper with Magnet .....	19
2.4.3 Special Screens .....	19
2.4.4 Feeding Hopper for Conveyor .....	20
2.4.5 Dust separating System .....	20
<b>3. Installation and Debugging .....</b>	<b>21</b>
3.1 Machine Location.....	22
3.2 Power Connectors .....	23
3.3 Options Installation .....	23
3.3.1 Installation of Dust Separating System.....	23
<b>4. Operation Guide .....</b>	<b>24</b>

4.1	Startup Pretest.....	24
4.1.1	After 2 Hours of First Startup.....	24
4.2	Startup and Shutdown .....	25
4.3	Open the Feed Box, Screen and the Storage box .....	25
4.3.1	Open Feed Box .....	26
4.3.2	Open the Screen Bracket .....	26
4.4	Close Feed Box, Mount Screen Bracket and Storage Box .....	27
4.4.1	Mount Screen Bracket and Storage Box .....	27
4.4.2	Close the Feed Box.....	27
<b>5.</b>	<b>Trouble-shooting.....</b>	<b>28</b>
5.1	The Granulator doesn't Work.....	28
<b>6.</b>	<b>Maintenance and Repair .....</b>	<b>29</b>
6.1	Repair .....	30
6.1.1	Operation and maintenance .....	30
6.1.2	Cleaning of Dust Separating System.....	30
6.1.3	Replacement of Blade .....	31
6.1.4	Conveying .....	32
6.1.5	Lubrication.....	33
6.2	Maintenance .....	34
6.2.1	Daily maintenance .....	34
6.2.2	Weekly Check .....	34
6.2.3	Monthly Check.....	34
6.3	Cleaning.....	35
6.4	Installation of Blade Rest and Bearing.....	36
6.4.1	Installation of Blade Rest Shaft (This Installation illustration is only suitable for SG-23).....	36
6.4.2	Installation of Blade Rest Shaft (This Installation illustration is only suitable for SG-30).....	37
6.4.3	Installation of material fender(This Installation illustration is only suitable for SG-23) .....	37
6.4.4	Installation of Bearing Block and Bearing.....	38
6.4.5	Installation of Bearing Cover Plate .....	38
6.5	Installation of Bearing, Motor, Belt Pulley and Belt .....	39
6.6	Installation of Screen, Screen Bracket and Storage box.....	40

6.7	Installation of Feed Box and Feed Port.....	40
6.8	Installation of Blades.....	41
6.9	Maintenance Schedule .....	42
6.9.1	About the Machine.....	42
6.9.2	Check after Installation .....	42
6.9.3	Daily Check .....	42
6.9.4	Weekly Check .....	42
6.9.5	Monthly Check.....	42
6.9.6	Check Half-yearly or Every 1000 Running Hours .....	43
6.9.7	Check Every 3 Years.....	43

### Table index

Table 6-1:	Blades and other fixing screw torque .....	31
------------	--	----

### Picture index

Picture 2-1:	Working principle.....	14
Picture 2-2:	Emergency stop switch .....	15
Picture 2-3:	Safety switch .....	16
Picture 2-4:	Star screw .....	16
Picture 2-5:	PCB Circuit board .....	17
Picture 2-6:	Main electrical components.....	18
Picture 3-1:	Installation space .....	22
Picture 3-2:	Installation 1 .....	22
Picture 3-3:	Installation 2 .....	22
Picture 4-1:	Startup and shutdown .....	25
Picture 4-2:	Open feed box.....	26
Picture 4-3:	Open the screen bracket.....	26
Picture 6-1:	Disassemble the rotary blades .....	32
Picture 6-2:	Maintenance of conveyor belt .....	33
Picture 6-3:	Adjustment of V-belt.....	33
Picture 6-4:	Lubricating method.....	34

Picture 6-5: Cleaning of Machine .....	35
Picture 6-6: Installation of blade rest .....	36
Picture 6-7: Installation of Bearing and Blade Rest 2 .....	36
Picture 6-8: Installation of Bearing and Blade Rest 3 .....	36
Picture 6-9: Installation of Bearing and Blade Rest 4 .....	37
Picture 6-10: Installation of Bearing and Blade Rest.....	37
Picture 6-11: Installation of material fender .....	38
Picture 6-12: Installation of bearing block and bearing.....	38
Picture 6-13: Installation of bearing cover plate.....	39
Picture 6-14: Installation of bearing, motor, belt Pulley and belt.....	39
Picture 6-15: Installation of screen, screen bracket and storage box .....	40
Picture 6-16: Installation of rotary blade and fixed plate (3).....	40
Picture 6-17: Installation of rotary blade and fixed plate (4).....	41

# 1. General Description



Please read this manual carefully before using this machine in order to operate correctly against any damage caused due to improper operation.



Note!

Always take great care when the knives are within reach, they are very **sharp** and can cause personal injury.



Forbidden to process flammable or toxic material!

SG-23/30 series sound-proof central granulator are suitable for granulating all kinds of plastic materials, including rejected parts from injection molding, blow molding or recycling of wastes. The machines feature optimized structure, easy operation, and quick blade replacement. Staggered rotating blades can easily grab and cut materials. This design can reduce energy consumption to the minimum. This granulator has various models with wide application to meet different customers' demand.



Model: SG-3060

## 1.1 Coding Principle

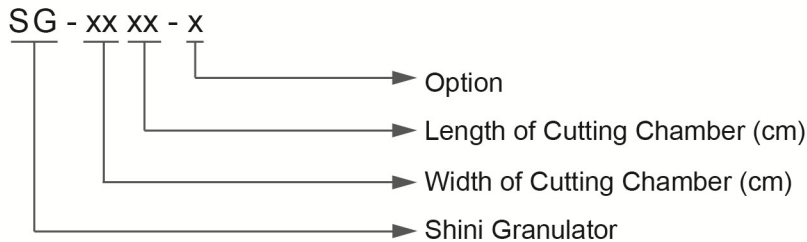

## 1.2 Feature

- SG-23 series adopts staggered blades, it can decentralize working load when granulating to increase cutting efficiency, Blade retainer is designed for quick blade replacement without readjustment.
- SG-30 series adopts paddle blades. It allows increased efficiency and reduced energy consumption.
- Blades adopt imported steel to ensure high quality and high durability.
- Full-closed design and sound-proofing ensure low noise level.
- Equipped with electrical current relay, motor overload protector and multiple safety devices.
- Cyclone dust separator can effectively remove the air from regrind and facilitates the material collecting.
- Dust collecting bag brings easiness for dust cleaning and reduce contamination.
- Regrind conveying system as standard.
- For SG-30, cooling water device at the rear plate of the cutting chamber can effectively cool down the cutting chamber and prevent materials from melting-up.
- SG-30 series equipped with presetting knife jig, rotating blades can be adjusted in the fixture outside the machine instead of machine inside. It made blades adjustment much easier.



All service work should be carried out by a person with technical training or corresponding professional experience. The manual contains instructions for both handling and servicing. Chapter 6 contains service instructions intended for service engineers. Other chapters contain instructions for the daily operator.

Any modifications of the machine must be approved by SHINI in order to avoid personal injury and damage to machine. We shall not be liable for any damage caused by unauthorized change of the machine.

Our company provides excellent after-sales service. Should you have any problem during using the machine, please contact the company or the local vendor.

Shini Hotline Service:

Headquarter and Taipei factory:

Tel: + 886 (0)2 2680 9119

Shini Plastics Technologies (Dongguan), Inc.:

Tel: +86 (0)769 8331 3588

Shini Plastics Technologies (Pinghu), Inc.:

Tel: +86 (0)573 8522 5288

Shinden Precision Machinery (Chongqing), Inc.:

+86 (0)23 6431 0898

## 1.3 Safety Regulations

Follow the instructions in this manual to avoid personal injury and damage to machine components.

### 1.3.1 Safety signs and labels



Electrical installation must only be done by a competent electrician!



Before the granulator is opened for servicing and maintenance, turn off both the main switch and the control switch on the granulator.



Never put any part of your body through the granulator openings, unless both the main switch and the control switch on the granulator are in "Off" position.



High voltage! Danger!

This sign is attached on the control box and the wiring box.



Be careful with the rotating knives, they are very sharp and can cause personal injury!



If the rotor must be turned manually-do this with great care!



The granulator should not be started before the feed box and storage box are properly closed.



Ear protection should be used during granulating of plastic materials.



Make sure the power has been cut off before opening the feed box.



Feeding blower which requires that the temperature of regrind and dust should not be higher than 80°C is applicable to convey regrind and dust.



The feeding blower has great suction power and it is easy to get goods or clothes sucked into, which will cause personal injury!



For SG-30, the cutting chamber should be heat-processed and the blades must be changed before the granulator deal with fibre added material.



Attention!

No need of regular inspection because all the electrical parts in the electric components box are fixed tight!



Warning!

When this light is on, it means overload working and growing flow. Please stop feeding until the light is off.



Attention!

1. After the first 1-2 days of operating, it's necessary to loose the four screws on motor fixing base and then tighten this screw up for tightening belt.

2. Whenever belt slip occurs, please tighten up this screw.



Air inlet

Clean dust.



Please add butter lubricant regularly.

When operate the granulator, please notice the following signs:

	<p>Water outlet (not for SG-23)</p>
	<p>Water inlet (not for SG-23)</p>
	<p>Motor rotation directio</p>

### 1.3.2 Transportation and Storage of the Machine

#### Transportation

- 1) SG-23/30 series of granulator are packed in crates or plywood cases with wooden pallet at the bottom, which is suitable for quick positioning by fork lift.
- 2) Equipped with castors for ease of movement after being unpacked.
- 3) Do not rotate the machine and avoid collision with other objects during transportation to prevent improper functioning.
- 4) The structure of the machine is well-balanced and possess good handling devices, however, it also should be handled with care when lifting the machine to prevent falling down.
- 5) The machine and its attached parts can be kept with a temperature from  $-25^{\circ}\text{C}$  to  $+55^{\circ}\text{C}$  for long distance transportation while for a short distance, it can be transported with temperature under  $+70^{\circ}\text{C}$ .

#### Storage

- 1) SG-23/30 series should be stored indoors with temperature kept from  $5^{\circ}\text{C}$  to  $40^{\circ}\text{C}$  and humidity lower than 80%.
- 2) Cut off all power supply and turn off main power switch.
- 3) Keep the whole machine, especially the electrical components away from water to avoid potential troubles caused by the water.
- 4) Use plastic film to cover the machine tightly to prevent the machine from dust and rainwater.

#### Working environment

Indoors with a dry environment of maximum temperature  $+45^{\circ}\text{C}$  and humidity no more than 80%

Do not use the machine:



- 1) If it is with a damaged cord.
- 2) On a wet floor or when it is exposed to rain to avoid electric shock.
- 3) If it has been dropped or damaged until it is checked or fixed by a qualified serviceman.

### 1.3.3 Rejected parts disposal

When the equipment has run out its life time and can not be used any more, unplug the power supply and dispose of it properly according to local code.



Fire alarm!

In case of fire, CO<sub>2</sub> dry powder fire extinguisher should be provided.



Flammable materials or materials which are contaminated by flammable materials/liquid should not be processed in the granulator. Serious risk of fire or explosion may occur.



It is very important to tighten the screw up as required.



If material is longer than feed port, please cut it off until it is shorter than the feed port before processing.



Please don't put soft and flexible materials thinner than 2 mm, like rubber, into the granulator.

## 1.4 Exemption Clause

The following statements clarify the responsibilities and regulations born by any buyer or user who purchases products and accessories from Shini (including employees and agents). Shini is exempted from liability for any costs, fees, claims and losses caused by reasons below:

1. Any careless or wrong installations, operation and maintenances upon machine without referring to the Manual prior to machine using.
2. Any incidents beyond human reasonable controls, which include man-made vicious or deliberate damages or abnormal power, and machine faults caused by irresistible natural disasters including fire, flood, storm and earthquake.
3. Any operational actions that are not authorized by Shini upon machine, including adding or replacing accessories, dismantling, delivering or repairing.
4. Employ consumables or oil media that are not appointed by Shini.

## 2. Structural Features and Working Principle

### 2.1 General Description

SG-23/30 series are suitable for granulating waste plastics for directly recycling use. Before granulating, it's necessary to clean metal scraps and dirt. Mount magnet at the material inlet to prevent metal scraps from getting into cutting chamber and bringing damage to the blades. The granulator is controlled through "Start/Stop" button and "Emergency stop" button.

#### 2.1.1 Working Principle

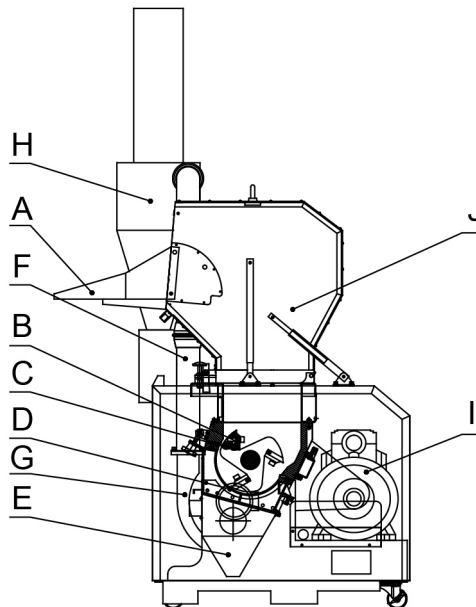

Parts name:

A. Material inlet B. Rotary blade C. Fixed blade D. Screen E. Storage bin

F. Discharging pipe G. Feeding blower H. Cyclone dust collector I. Motor

J. Feed box

Picture 2-1: Working principle

The waste materials enter the cutting chamber via material inlet (A). The rotary blade (B) and fixed blade (C) granulate the materials. The particle size is controlled by the size of screen (D). The screen (D) is located at the bottom of cutting chamber. Thus it is convenient to replace screen to other different sizes.

The granulated materials are dropped into the storage box (E) via the screen and be conveyed via discharging pipe (F). Use feeding blower to absorb the granulated materials into cyclone dust collector to separate the air and dust. The particles can be reused directly or sent to somewhere for storage after being granulated.

The feed box is foldable, thus it is very convenient for cleaning.

## 2.2 Safety System

The fast-rotating blade in the granulator is prone to result in an accident. Therefore, the granulator is equipped with a highly-secure safety system to avoid accident during the operation.

### 2.2.1 Emergency Stop

Emergency stop is a red button on the control panel. Once press it, the power will be cut off and then the machine will stop working. It can be reset by turning the button as the arrow direction (clockwise).



Picture 2-2: Emergency stop switch

### 2.2.2 Safety Switch

There are safe position switches in the granulator. If it's on or loose, it will cut off the power and stop the machine. Two safety switches may be involved. One is located between the feed box and the cutting chamber and the other is on the storage box.

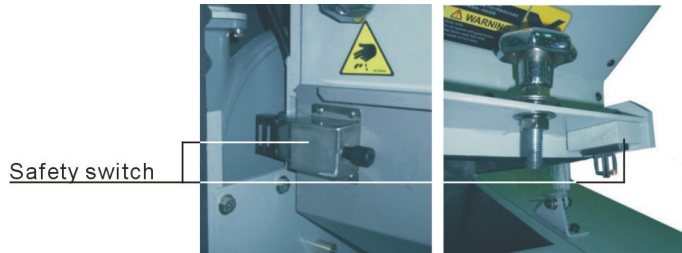

Picture 2-3: Safety switch

### 2.2.3 Star Screw

Star screws on feed box and screen bracket are very important parts of safety operation system of the granulator. When unscrewing those star screws, blades will stop running to avoid personal injury.



Picture 2-4: Star screw

***Caution: The star screws can't be loosened unless the machine is not working.***

***Before starting the machine, the star screws on feed box and screen bracket should be tightened up and a storage box should be assembled. Then close the front door of granulator and lock it tightly.***



## 2.3 Electrical Components Instruction

### 2.3.1 Microprocessor Board (PCB)

- Function:
- 1) Star-delta starting.
  - 2) Granulating motor overload detection and alarm.
  - 3) Material conveying blower postpones machine stop.
  - 4) phase sequence dection, warning and machine halt.

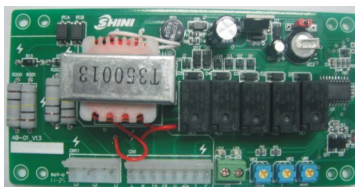

Picture 2-5: PCB Circuit board

Scale of Variable Resistor 	1	2	3	4	5	6	7	8	9
Fine Adjustment I(A):VR1	-4	-3	-2	-1	0	+1	+2	+3	+4
Rate Current setting (I) : VR3	5A	10A	20A	30A	40A	50A	60A	70A	80A

Scale of Variable Resistor 	1	2	3	4	5	6	7	8	9
Y/Δ Start Switching	3S	6S	9S	12S	15S	19S	22S	24S	30S

### 2.3.2 Electrical Components in Electrical Components box

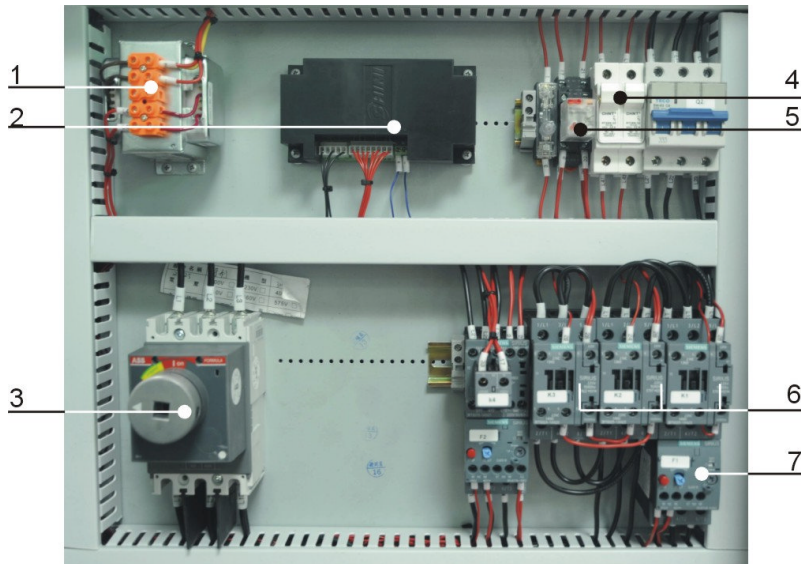

Picture 2-6: Main electrical components

1. Transformer, which supplies proper voltage for control circuit.
2. PCB which controls the start and stop of the machine.
3. Gate circuit breaker, which can perform the function of circuit isolation and protection.
4. Circuit breaker, which performs the function of overloading protection and short circuit protection in control circuit.
5. Intermediate relay, which performs the function of switch and connection of contact point in control circuit.
6. Contactor, which can switch on and switch off the main circuit from a long distance.
7. Thermo overload relay, which can protect the motor when overloading or open phase.

## 2.4 Optional Accessories

### 2.4.1 Full-receiver Alarm Device

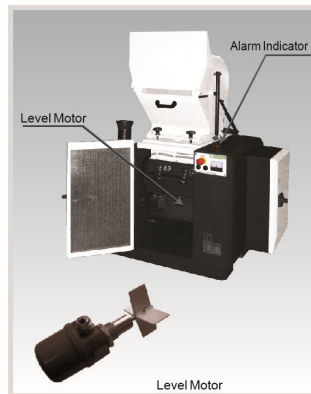

Full-receive alarm device helps to realize unmanned operation and no materials will be wasted. Whenever the regrind level reaches the motor position, the machine will be forced to stop and be cut off via its sensor, thus stop the granulator and warn the user by sounding an alarm. Add "FAD" at the end of the model code.

### 2.4.2 Feed Hopper with Magnet

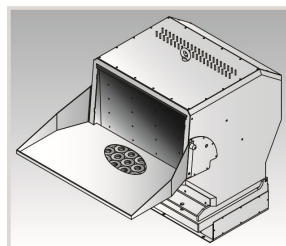

Feed hopper with magnet is used to take out metal craps and impurities in the material. Add "FHM" at the end of the model code.

### 2.4.3 Special Screens



Special screen mesh sizes:  $\Phi 4, \Phi 6, \Phi 10, \Phi 12$ (mm) for SG-23/30 series,  $\Phi 8, \Phi 12, \Phi 17, \Phi 25$  (mm) for SG-36 series. Add "SS + screen diameter" at the end of the model code, e.g.:  $\Phi 6$ mm , add "SS06".

## 2.4.4 Feeding Hopper for Conveyor



Material feeding for large granulators is quite a difficult matter. They are generally installed at a lower place or a platform must be built for material feeding. Shini particularly designed the belt conveyor to easily convey the material into the cutting chamber of SG-36 series. Add "BCF" at the end of the model code.

## 2.4.5 Dust separating System

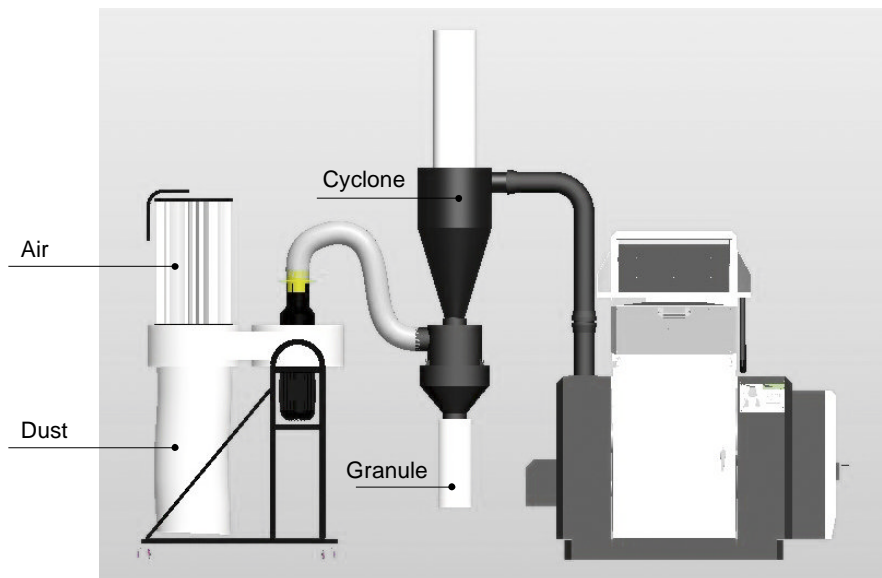

Work with cyclone dust separator to recycle the granule and separate it from dust.

### 3. Installation and Debugging



Read through this chapter before installation.



Install as following orders to avoid any accident!



Be careful! Not to be cut by the sharp blade.



Power connection must be done by the professional electrician to avoid electrical shock.



Caution!

Blades should be placed stably; prevent the blades from self-rotating when installing it.

When operating it, don't put your hands near to the blades to avoid personal injury.



Caution!

Do not install the blades by working together, since it may bring personal injury. Use a thick wood block to lock the rotary blades. .



Caution!

Use protective gloves to avoid being cut, since the blades are very sharp.



Notice!

Please use new screws and gaskets when installing blades.



The power connection of the granulator should be carried out by professional electrician to avoid electrical shock!

### 3.1 Machine Location

Make at least 1 meter clearance around the machine to facilitate repair and maintenance.

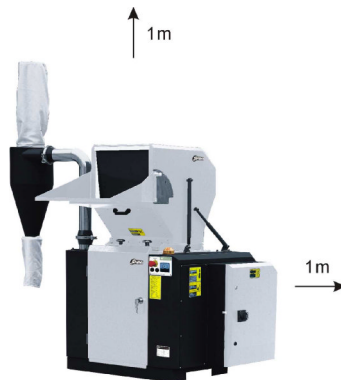

Picture 3-1: Installation space

Adjust the Granulator with spirit level, and put it on ground floor.

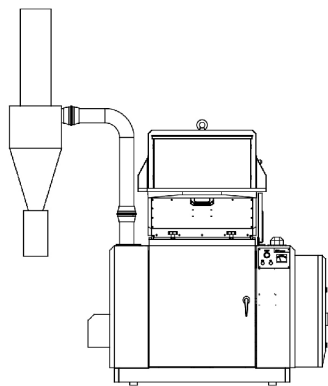

Picture 3-2: Installation 1

SG-23/30 is equipped with castors and rabbets for fork lift to convey the machine.

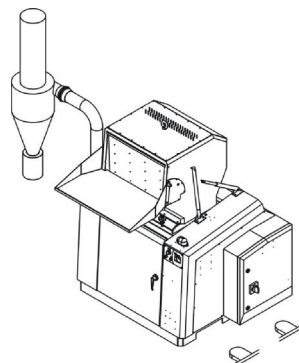

Picture 3-3: Installation 2

## 3.2 Power Connectors

- 1) Make sure voltage and frequency of the power source comply with those indicated on the nameplate, which is attached to the machine by the manufacturer.
- 2) Power cable and earth connections should comply with local regulations.
- 3) Use independent power cable and power switch. The cable's dia. should not be smaller than those applied in the control box.
- 4) The power cable connection terminals should be tightened securely.
- 5) This series adopts three-phase and four-wire power: L1, L2, L3 are connected to the fire wire while the PE line connected to the ground wire.
- 6) Power supply requirements:  
Main power voltage:  $\pm 5\%$   
Main power frequency:  $\pm 2\%$
- 7) Power connection refers to the circuit diagram of each model.

## 3.3 Options Installation

### 3.3.1 Installation of Dust Separating System

***Note: Read chapter 2 carefully before operating dust separating system.***

The circuit connection of the system should be done by professional electrician.

Before first startup

The unpainted parts of the machine are protected with oil prior to sending out. Clean the granulator from rust protection agent before it is used.

Connection

- 1) Place a separator under cyclone device, the diameter is  $\Phi 150\text{mm}$ .
- 2) Connect to conveying pipe, the diameter is 4".
- 3) Mount dust collection device including air and dust collection bags.
- 4) Place a container under the separator to help collecting plastic material after dust removing.

***Note: If use cloth bag to connect the separator, please make sure a good ventilation within the cloth bag.***

## 4. Operation Guide



Wear earplugs when operating to avoid personal injury!



Wear gloves when operating to avoid personal injury!



Wear goggles when operating to avoid personal injury!



Since the blades and blade shaft may be loosen, check the following items before operating:

- 1) If the blades have any damage;
- 2) If the surface of blade shaft is loosen;
- 3) Push or pull the rotary blade rest and blades to see if there is any loose.

If any of the above situations occurs, please contact the local representative or SHINI Company.

### 4.1 Startup Pretest

1. Unpainted part of the machine has been spread with anti-rust oil. Before use, clear the anti-rust oil carefully.

- 1) Clean it with a rag first.
- 2) Then wet the rag with thinner to clean it.

2. Check the clearance of blades (0.20~0.30mm) and see if the screws of blades are locked tightly.

#### 4.1.1 After 2 Hours of First Startup

Check the clearance of blades again, including fixed blades and rotary blades; then check the screws of blade to see if there is any loose.



## 4.2 Startup and Shutdown

The startup and shutdown of SG-23/30 series are controlled by the start switch and stop switch on control panel.



Picture 4-1: Startup and shutdown

***Note: If there are still materials which have not been granulated in feed box and cutting chamber, the machine should not be shut down. Otherwise, the materials left inside will block the blade rest shaft and make the motor overloaded and trip when restarting.***

## 4.3 Open the Feed Box, Screen and the Storage box



For SG-23/30 series, it's necessary to turn off the main power before opening the feed box, screen and storage box.



Caution!

The blade is very sharp; it may cause personal injury.



Caution!

Be careful when closing feed box, screen bracket and storage box to prevent them from crushing.

Clean internal surface before closing feed box, screen bracket and storage box.

#### 4.3.1 Open Feed Box

- 1) Make sure the feed box and cutting chamber are empty inside before turning off the machine.
- 2) Loosen the star screws on feed box.
- 3) Open the feed box backward.

***Note: The feed box of SG-23/30 Granulator is supported by a piece of air spring and two pieces of sleeves, which could open the feed box backwards by supporting.***



Picture 4-2: Open feed box

#### 4.3.2 Open the Screen Bracket

- 1) Open the door of granulator.
- 2) Turn the screw handle on storage box to loosen the piece of metal insert of safety switch.
- 3) Take out the storage box.
- 4) Loosen the star screws on screen bracket.
- 5) Take out the screen bracket; the screen can be took off for replacing or cleaning.

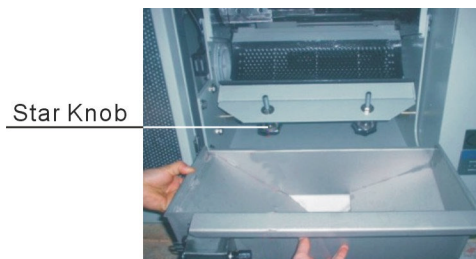

Picture 4-3: Open the screen bracket

***Note: Hold the screen bracket while loosening the star screws to prevent it from falling off.***

## 4.4 Close Feed Box, Mount Screen Bracket and Storage Box

***Note: Clean the joint surface first before closing it. Be careful! Do not crush it when closing it!***

### 4.4.1 Mount Screen Bracket and Storage Box

- 1) Place the screen bracket in specified position and put the screen on it.
- 2) Hold up the screen bracket and lock the star screw tight.
- 3) Mount the storage box.
- 4) Turn the screw handle on storage box to lock the piece of metal insert of safety switch tight.
- 5) Close the door of granulator.

### 4.4.2 Close the Feed Box

- 1) Make sure there is no powder on the joint surface or in the corner.
- 2) Close the Feed Box.
- 3) When closing the feed box, the pothook should be directed at the slot.
- 4) Screw up the star screws.

## 5. Trouble-shooting

### 5.1 The Granulator doesn't Work

- 1) 1) Check if the emergency stop has been reset or not. If not, rotate the button anti-clockwise to reset it.
- 2) 2) Check if the safety switch between feed box and storage box is completely closed. If not, machine can not be started.
- 3) Checking overload protector of the motor.

The overload protector in the electrical control box will work if the motor overloads. Test white key (A) turn left, press the "Reset" button (B) to reset it. Before it starts again, check whether there is any powder left in the granulator.

- 4) Check the overload protector of the feeding blower's motor.  
If the feeding blower does not run, the granulator can run neither. Check the motor protector in the electric control box. If the protector is closed, the switch will be at "0" position, reset it to "1" position. Check if there's no leftover, then re-start the machine. Test the white key(A) turn left, press "Reset" key (B) to reset it.
- 5) Check the clearance between the blades  
The stop will happen or the motor overload protector will work if the blade is very blunt or the space between blades is not correct. Protector will be tripped if motor is overload. Blades should be checked, replaced or adjusted between the blades.
- 6) The contactor is burnt down or the control circuit is break off.

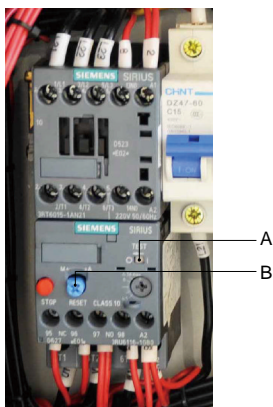

## 6. Maintenance and Repair

All maintenance should be done by professional personnel, so as to avoid personal injury and machine damage.

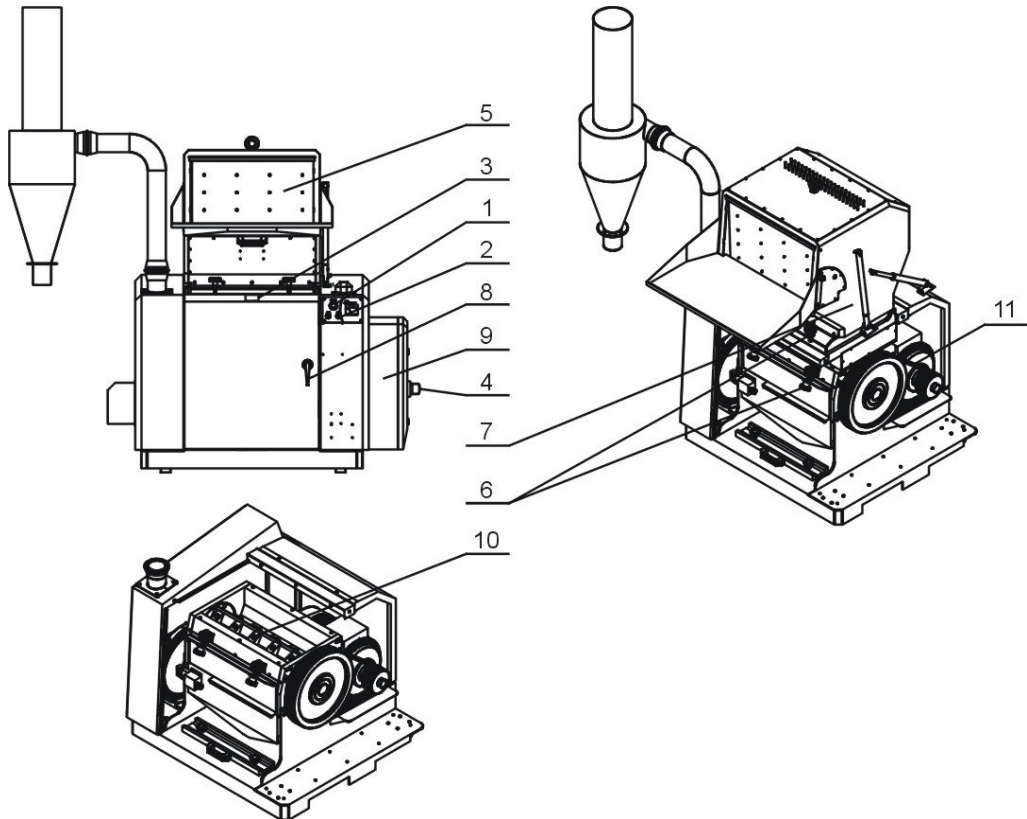

1. Check whether the emergency stop button works normally. Period: Daily.
2. Check whether the start/stop button works normally. Period: Daily.
3. Check whether the safety switch works normally. Period: Daily.
4. Check whether the gate circuit breaker works normally. Period: Daily.
5. Check the material defender before starting. Period: Daily.
6. Check whether the screws on the feed box and cutting chamber are tighten before starting. Period: Weekly.
7. Check whether there is metal in the cutting chamber before starting. Period: Daily.
8. Check the whether the front door is locked tight before starting. Period: Daily.
9. Check whether the electrical elements in the electric control box are loose. Period: Monthly.

10. Check the screws on both the fixed and the rotary blades are loose.

Period: Weekly.

11. Check the belt tension. Period: Monthly.

## 6.1 Repair

All the repair work should be done by professionals in order to prevent personal injuries and damage of the machine.

### 6.1.1 Operation and maintenance

#### Daily Check

Air and dust bags: Check if these bags are damaged. If there is any damage, please replace them.

Conveying pipe: Check if the conveying pipe is damaged. If it is, please replace it.

Check if the connecting joint is connected well and sealed.

Check if the dust collection bag is full. If it is, please empty it.

Storage box: Check if the storage box is placed right under the dust separator. If it's not, please adjust it.

Check the storage box. If it is full, take out in time the plastics which has been dust removed.

#### Weekly check

Check if the wire has any damage and the connecting situation.

If it has any damage, please fix it.

### 6.1.2 Cleaning of Dust Separating System



Clean the machine when the processing material is changed or after every 300-hour running time. Before cleaning, please cut off the power.

- 1) First, clean the inner side of the device.
- 2) It is necessary to check and clean dust separator.
- 3) Move away separator and use high pressure air to blow away its interior granules.
- 4) Clean out the storage hopper and clean its interior.
- 5) Shake the air bag to drop the dust down.

6) Assemble the disassembled parts according to the reverse order.

### 6.1.3 Replacement of Blade



Caution! The blades are very sharp; wear gloves when holding them.



When replacing blade, the fixing screws (inner hexagon screw M10 x 40 for SG-23 while M14 x 50 for M14 x 50; intensity: 12.9) of blade should be replaced with new ones.

Table 6-1: Blades and other fixing screw torque

Threading Type	Threading Specification	Stretching Force Fv(N)			Tightening Torque Ma(N.M)		
		Grade 8.8	Grade 10.9	Grade 12.9	Grade 8.8	Grade 10.9	Grade 12.9
Coarse Thread	M4	3900	5750	6700	3.0	4.4	5.1
	M5	6400	9400	11000	5.9	8.7	10
	M6	9000	1320	15500	10	16	18
	M8	16500	24300	28400	25	36	43
	M10	26300	38700	45200	49	72	84
	M12	38400	56500	66000	86	126	145
	M14	62500	77500	90500	135	200	236
	M16	72500	10700	12500	210	310	365
	M18	91000	129000	152000	300	430	600
	M20	117000	166000	195000	425	610	710
	M22	146000	208000	244000	580	820	960
	M24	168000	240000	281000	730	1050	1220
	M27	222000	316000	369000	1100	1550	1800
M30	269000	384000	449000	1450	2100	2450	
Fine Thread	M8×1	18100	26600	31200	27	39	46
	M10×1.25	28300	41600	48700	52	76	90
	M12×1.25	43300	63500	74600	93	135	160
	M12×1.5	40800	60000	70000	89	130	155
	M14×1.5	58600	86000	100000	145	215	255
	M16×1.5	79500	116000	136000	226	330	390
	M18×1.5	108000	152000	177000	340	485	570
	M20×1.5	134000	191000	224000	475	680	790
	M22×1.5	166000	236000	276000	630	900	1050
	M24×2	189000	270000	316000	800	1150	1350
	M27×2	246000	350000	409000	1150	1650	1950
M30×2	309000	440000	515000	1650	2350	2750	

**Note: Do not finish installation of blades with help from others to avoid personal injury. Lock the blade rest shaft with a thick wood block on the cutting chamber.**

- 1) Open the door of granulator to take out the screen and open feed box.
- 2) Loosen screws of fixed blade press block and take out the fixed blade.
- 3) Loosen screws of rotary blade press block and take out the rotary blade.
- 4) After taking out the blades, clean the blade installation groove.
- 5) Re-assemble prepared new blades. Check whether the screen meshes are out of shape. If there is any meshes turn to be oval, replace the screen immediately.
- 6) Turn the blade rest shaft and check the clearances between blades until all the clearances meet the requirement.

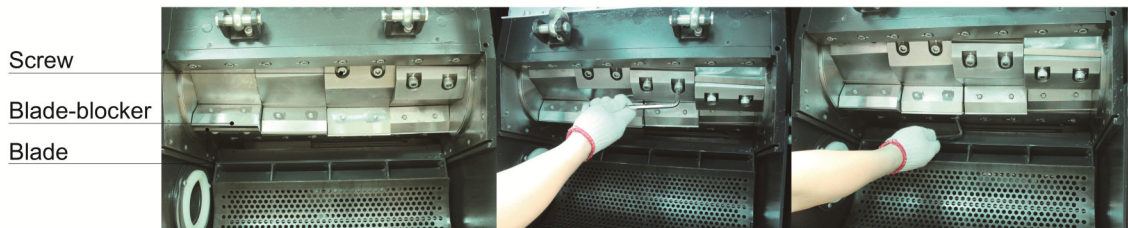

Picture 6-1: Disassemble the rotary blades

#### 6.1.4 Conveying

##### 6.1.4.1 Daily Maintenance and Adjustment of V-belt

Granulator is driven by 4 V-belt. The specification of the V-belt is XPA.

- 1) Inspect V-belt  
After 20-30 hours of full-load operation, inspect the tension of V-belt and running situation. Then, check the abrasion of belts every month.
- 2) Inspect the tension of V-belt every 6 months.  
Loosen the screws which are on right shell and for fixing the electric control box and then take out the upper cover plate of granulator. Turn the V-belt for several circles to see whether the belt is damaged and worn.

**Caution: Do not put the hand between belt and belt pulley. Otherwise, the hand may be jammed; inspect the tension of belt, and adjust it if necessary.**

- a) For motor of 7.5kW, press the belt which is between the two belt pulleys with force of 205 N. The belt should not be stretched downward over 5mm.



b) For motor of 11kW, press the belt which is between the two belt pulleys with force of 297N. The belt should not be stretched downward over 5mm.

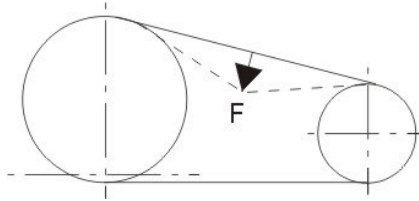

Motor of 7.5kW L=5mm F=205N For motor of 11kW L=5mm F=297N

Picture 6-2: Maintenance of conveyor belt

#### 6.1.4.2 Adjustment of V-belt

- 1) Open the rear base plate of the granulator as well as the front door.
- 2) Loosen the screw handle and take out the storage box.
- 3) Adjust the two outer hexagon screws and adjust the belt tension by changing the space between the big and small belt pulley.

Recheck the belt tension after 20-30 hours of full-load operation.



Picture 6-3: Adjustment of V-belt

#### 6.1.5 Lubrication

6.1.5.1 Lubricating Oil Specification (The following brands of lubricating oil are options.)

Xin Chang Long: FX-00

FX-000

Bp: BP Grease LGEP 2

ESSO: Beacon Ep2, Beacon EP2

Mobil: Mobilux EP2

Shell: Shell Alvania EP2

Texaco: Multifak Ep2, Novotex Grease EP2

### 6.1.5.2 Please add lubricating oil to the bearing regularly.

Open the bearing cover and add lubricating oil.



Picture 6-4: Lubricating method

## 6.2 Maintenance

### 6.2.1 Daily maintenance

- 1) There is a rubber baffle in feed box. Check whether the rubber baffle is damaged. If it is, replace it immediately. Otherwise, the broken part may fall to the cutting chamber and cause damage to the blades. Besides, if the baffle is damaged, the material may pop out from the feed box.
- 2) Check whether the emergency stop button works normally, then turn on the switch for emergency stop after starting the machine. Rotate the button according to the direction of arrow (Clockwise) to reset .

### 6.2.2 Weekly Check

- 1) Check the power supply wire to see whether they are worn or damaged. If so, replace them immediately.
- 2) Check the performance of safety switch.
- 3) Check the safety switches of feed box and storage box.  
Loosen the star screws on feed box and screen bracket and try to start the machine (the machine can not be started if the door and screen bracket are not closed completely or the star knob is not tightened completely).

***Note: When inspection, the storage box should be mounted and the door should be closed and locked tight.***

### 6.2.3 Monthly Check

- 1) Check whether the belt is in good condition.
- 2) Check the tension of V-belt every 6 months; see chapter 6.2 "Conveying" for details.

## 6.3 Cleaning

**Caution: Make sure the main power switch is turned off before cleaning.**

**Note: When opening the feed box, be careful with the blades; they are very sharp and may cause personal injury.**

- 1) Check whether the feed box and cutting chamber are empty before stopping the machine.
- 2) Clean the outside surface of the feed box.
- 3) Loosen the star screws on feed box.
- 4) Open the feed box backward.
- 5) Clean the feed port.
- 6) Take out the material fender assembly and clean its both sides.
- 7) Open the front door of granulator and unscrew the screw handle to open the plug-in safety switch and take out the storage box.

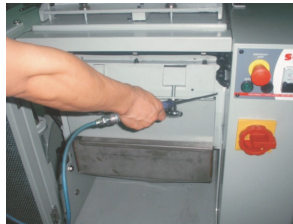

Picture 6-5: Cleaning of Machine

**Note: Use a protective sleeve to cover the safety switch in case anything goes in.**

- 8) Loosen the star screws on screen bracket and take down the screen bracket.
- 9) Loosen and clean the screen and hold the screen bracket to prevent it from falling off at the same time.
- 10) Blow compressed air into the material clear holes on the left and right side plates of cutting chamber and turn the blade bracket at the same time, which can clear materials stuck in the bearing block. It's recommended to do this cleaning once a day.
- 11) Clean the storage box and screen bracket.
- 12) Clean both inside and outside surfaces of the cutting chamber.
- 13) Clean the feeding pipe, feeding blower and cyclone dust collector.

## 6.4 Installation of Blade Rest and Bearing

### 6.4.1 Installation of Blade Rest Shaft (This Installation illustration is only suitable for SG-23)

- 1) Put oil seal and bearing orderly into bearing block.

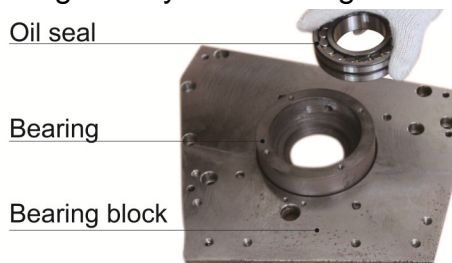

Picture 6-6: Installation of blade rest

- 2) Insert blade shaft vertically into blade rest, let hydraulic machine compress it tightly.
- 3) Mount shaft sleeve and material fender orderly into the main shaft and to make the material fender completely match shaft sleeve and blade rest.
- 4) Mount bearing pedestal onto the blade rest and use hydraulic machine to press tight.

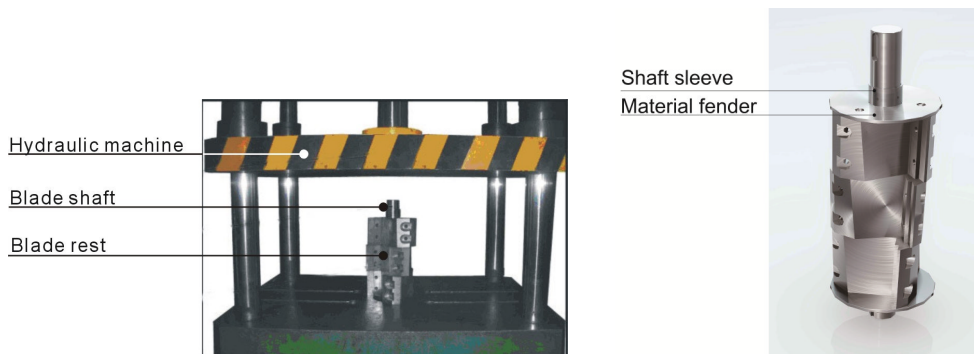

Picture 6-7: Installation of Bearing and Blade Rest 2

- 5) Put the installed blade rest into the cutting chamber.

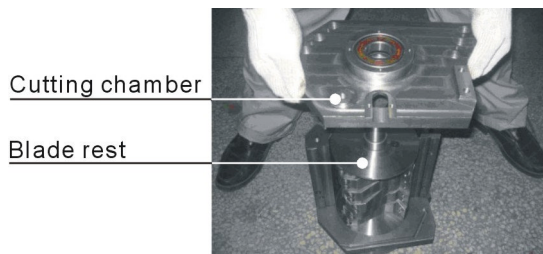

Picture 6-8: Installation of Bearing and Blade Rest 3

- 6) Install the bearing cover and tighten it by screw.

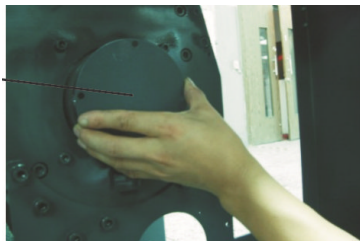

Picture 6-9: Installation of Bearing and Blade Rest 4

#### 6.4.2 Installation of Blade Rest Shaft (This Installation illustration is only suitable for SG-30)

- 1) Lock up the left, right, front and back block of cutting chamber by screw, then install right side of material feeder.
- 2) Put the blade rest inside the bearing block.
- 3) Put the material feeder and left bearing block into the bearing of blade rest, and lock them tightly on the left side of block of cutting chamber.
- 4) Install the shutter ring and bearing cap. Then, lock it up with screws.

**Note: Add some lubricating oil in both bearing and bearing block.**

- 5) Check the gap between left and right blade rest, finally install bearing cover and lock it up, avoid axial movement of right bearing.



Picture 6-10: Installation of Bearing and Blade Rest

#### 6.4.3 Installation of material fender(This Installation illustration is only suitable for SG-23)

Put the blades stand vertically first as well as lay the shaft sleeve level on the blade rest shaft. Next, put a sleeve which fits the inner hole over the shaft sleeve and then pressing the shaft sleeve in by using the oil press or slightly beating it into by using copper bar. After installing the shaft sleeve, put the material fender

onto the shaft sleeve: 3 holes on the material fender should be aimed to the 3 M8 holes on blade rest; the 3 M8 holes should be filled with screw locking agent. At last, tighten the two parts up with 3 countersunk hexagon screws M8x16.



Picture 6-11: Installation of material fender

#### 6.4.4 Installation of Bearing Block and Bearing

Clean up the internal holes of bearing block. There should not be any scrap iron or sundries. Turn the bearing block over to make its back side upward and then slightly beat the oil seal in and spread lubricating grease onto it. After finishing that, the bearing can be put into the bearing block smoothly by using the oil seal to press it in or using the copper bar to beat it in.



Picture 6-12: Installation of bearing block and bearing

#### 6.4.5 Installation of Bearing Cover Plate

Use blower gun to clean up the bearing roller and spread plenty of lubricating grease on them. And then put on the bearing cover plate and tighten it up with screws.

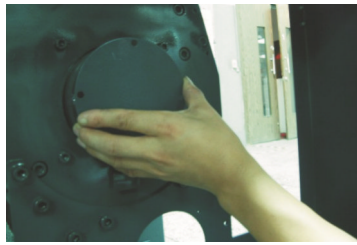

Picture 6-13: Installation of bearing cover plate

## 6.5 Installation of Bearing, Motor, Belt Pulley and Belt

- 1) Install baffles at both of the right and left sides of blade rest.
- 2) Spread lubricating grease on bearing and bearing block and then put the bearing into bearing block.
- 3) Use oil press to press the bearing to the bearing installation position on rotation shaft.
- 4) After fixing the cutting chamber and base, put the blade rest into the cutting chamber in the order from the left to the right and then tighten the bearing block up with screws.
- 5) Lock the bearing cover well and put bolts into key grooves.
- 6) Set the big belt pulley on the shaft and install the locking ring. And then tighten the locking ring after using dial gauge to adjust the big belt pulley.
- 7) Install the motor and position-adjusting plate on motor fixing plate (don't tighten them up)
- 8) Use level ruller to adjust the level of large and small pulley and then lock it tightly.

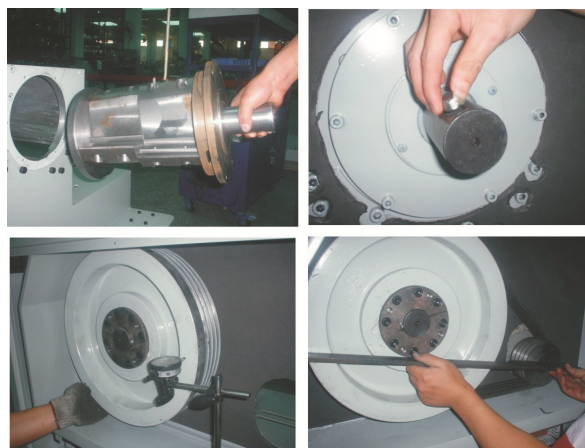

Picture 6-14: Installation of bearing, motor, belt Pulley and belt

## 6.6 Installation of Screen, Screen Bracket and Storage box.

- 1) Put the screen into screen bracket.
- 2) Hold up the screen bracket and hang its back pothook to the two side fixing plates of the end plate.
- 3) Hold up the screen bracket to a proper position which match with the bearing block. Then, tighten up the star screws.
- 4) Insert the storage box into the grooves at the two sides of end plate.
- 5) Install the safety switch.

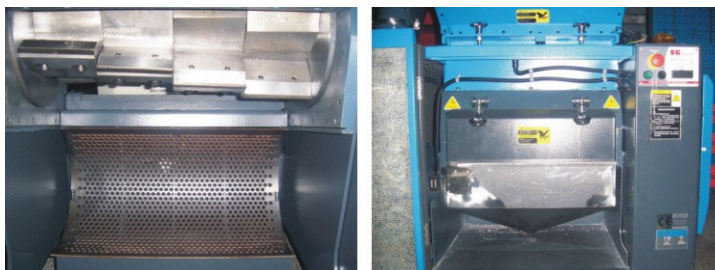

Picture 6-15: Installation of screen, screen bracket and storage box

## 6.7 Installation of Feed Box and Feed Port

- 1) Lift up the feed box to level with the cutting chamber and then fix it with an iron bar.
- 2) Mount the pneumatic connecting bar at the right side of feed box.
- 3) Lock the feed box and the cutting chamber with star knobs.
- 4) Respectively install one fixing plate at the two sides of feed box and use rivets to fix them. Then install the feed port.



Picture 6-16: Installation of rotary blade and fixed plate (3)



## 6.8 Installation of Blades

**Note: The blades are very sharp; please wear gloves before installing and be careful during operating to avoid cut!**

- 1) First, clean the front and rear box blocks as well as the press plate of rotary blade.
- 2) Place the rotary blade into the groove; cover it with press plate and lock them by screws.
- 3) Install the front and rear press plates of fixed blade respectively on front and rear box block; reserve some clearance for fixed blades.
- 4) Put set screws into front and rear adjusting holes of fixed blade to easily drive the fixed blade to adjust the clearance.
- 5) Place the clearance gauge between the fixed blade and rotary blade as well as set the clearance to be 0.20~0.30mm (the clearance should not be too small in case it damages the blades.)
- 6) After adjusting the clearance, lock the front and rear fixed blades tight.

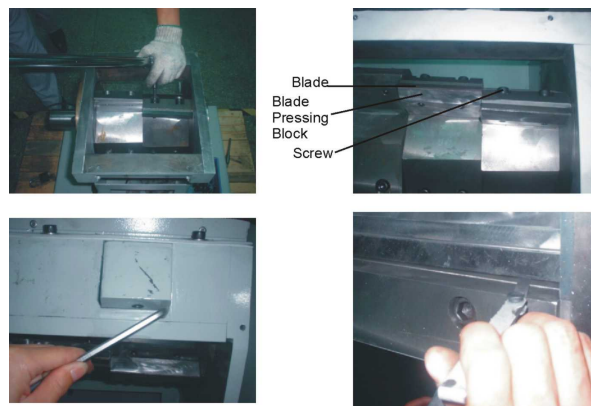

Picture 6-17: Installation of rotary blade and fixed plate (4)

**Note!: Srew specifications for rotary blades: inner hexagon M10 x 40 for SG-23 while M14 x 50 for SG-30; intensity: 12.9.**

**Srew specifications for fixed blades: inner hexagon M8 x 30 for SG-23 while M8 x 30 for SG-30; intensity: 12.9.**

**Note: The fixing screws of blades must be tightened tight to avoid personal injury and machine damage.**

**Note: The clearance between blades should not be too small in case it damages the blades.**

## 6.9 Maintenance Schedule

### 6.9.1 About the Machine

Model: \_\_\_\_\_ SN: \_\_\_\_\_ Manufacturing date: \_\_\_\_\_

Voltage: \_\_\_\_\_  $\Phi$  \_\_\_\_\_ V Frequency: \_\_\_\_\_ Hz Total power: \_\_\_\_\_ kW

### 6.9.2 Check after Installation

- Check if the feed box, screen bracket and storage box are locked tight.
- Check the clearance between fixed blade and rotary blade (0.2~0.3mm).
- Check the dynamic balance of belt pulley.

#### Electrical Installation

- Voltage: \_\_\_\_\_ V \_\_\_\_\_ Hz
- Specs of the fuse: 1 Phase \_\_\_\_\_ A 3 Phase \_\_\_\_\_ A
- Check phase sequence of the power supply.
- Check the turning direction of the conveying blower.

### 6.9.3 Daily Check

- Check main power switch.
- Check emergency stop button.
- Check start / stop button.
- Check if the material fender (strip) is in good condition.
- Check whether emergency stop and safety switch works normally.
- Clean screen and feed box.
- Check whether start, stop and power switches works normally.

### 6.9.4 Weekly Check

- Check all the electrical cables.
- Check if there are loose connections of electrical components.
- Check blade condition.
- Check whether the screws for fixing the fixed and rotary blades are loose.
- Check if there is abnormal noise, vibration and heat in reduction gear.
- Check the cracking condition of the window.

### 6.9.5 Monthly Check

- Check the pneumatic bracket.

- Check the delay function of feeding motor.
- Check the overload protection function of the motor.
- Check the tightness of the blades.
- Check whether the belt pulley clamp is tight.
- Check belt tension.

#### 6.9.6 Check Half-yearly or Every 1000 Running Hours

- Check the lubrication of bearing, motor and hopper shaft.
- Check the belt pulley.
- Check the two end plates.
- Assess the condition of the whole machine.

#### 6.9.7 Check Every 3 Years

- Replace PC board
- Relace no-fuse switch.