

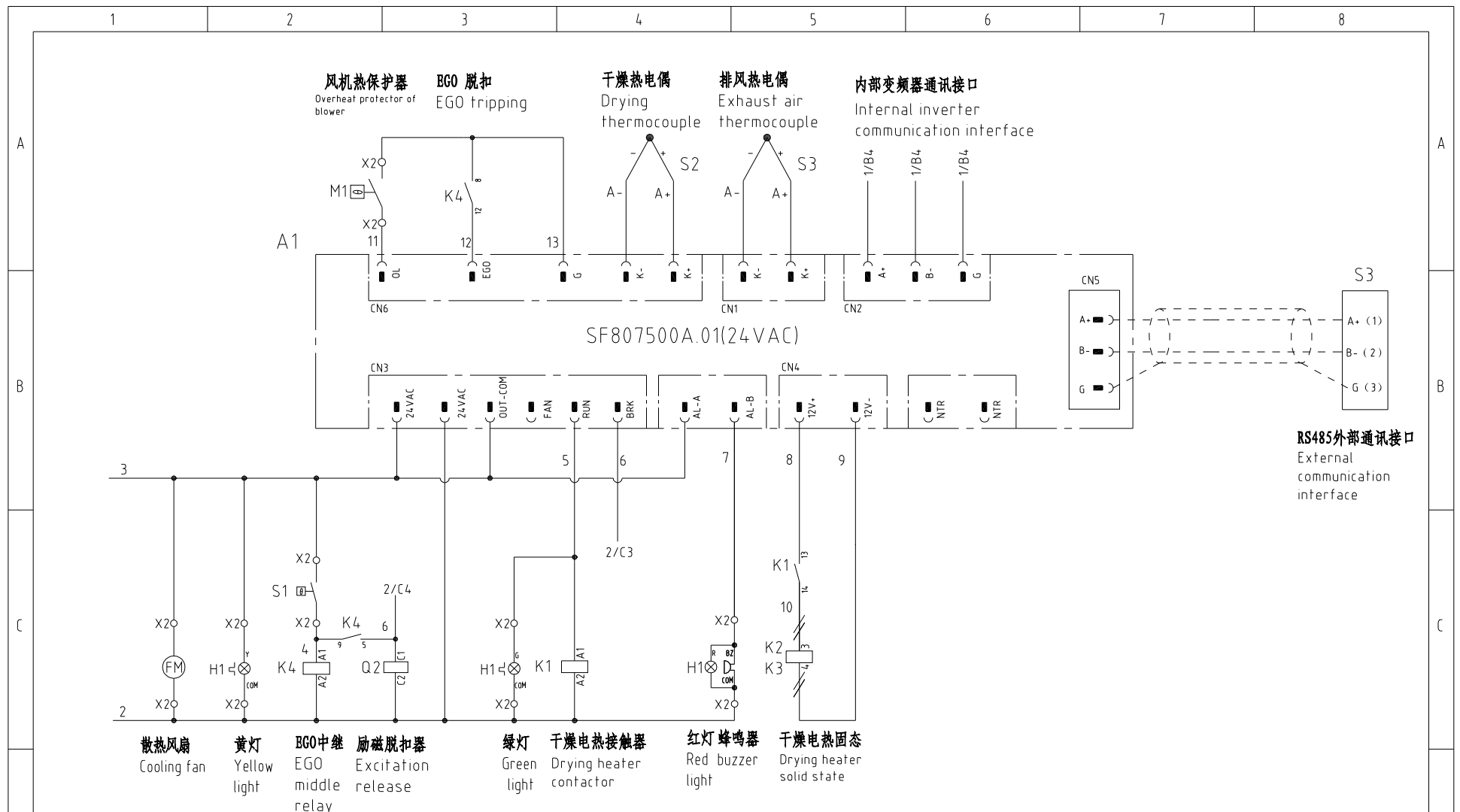

机型版本 Ver.B

					制图	版号	0	标题	SEHD-50-EC	图号	SEHD-50-EC-CE-400V-0-1	比例	第 1 张
					设计	核		主电路图				标准	CE
					校对	准		 <b>信易电热机械股份有限公司</b> <b>Shini Plastics Technologies, Inc.</b>		机器电压		3φ400V	
标记	更改前	更改后	更改人	日期	审核	日期	2024.03.13			机器频率		50Hz	



机型版本 Ver.B					制图	版号	0	标题	SEHD-50-EC	图号	SEHD-50-EC-CE-400V-0-2	比例	第 2 张
					设计	核准		控制电路图		标准	CE	共 5 张	
					校对	日期	2024.03.13	 <b>信易电热机械股份有限公司</b> Shini Plastics Technologies, Inc.		机器电压	3φ400V		
标记	更改前	更改后	更改人	日期	审核					机器频率	50Hz		

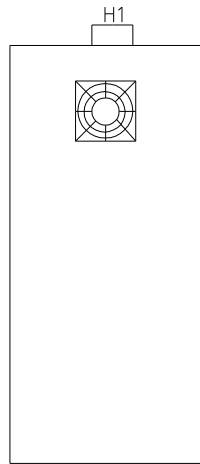

电控箱左侧  
Left side of control box

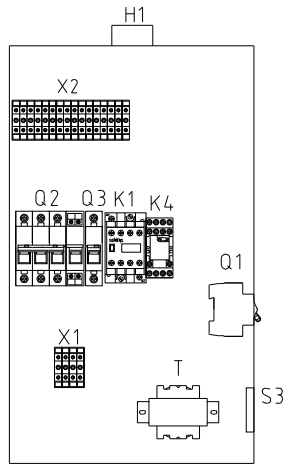

电控箱内部  
Inside the electric control box

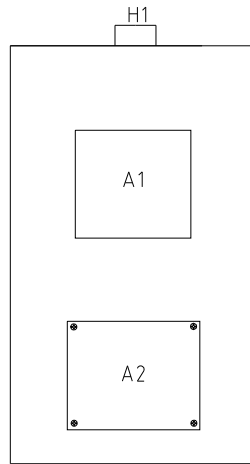

电控箱门板  
Electrical Control Box Door Panel

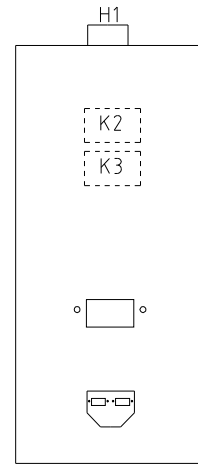

电控箱右侧  
Right side of electrical control box

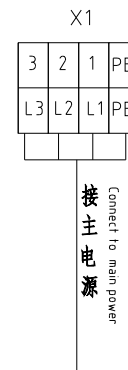
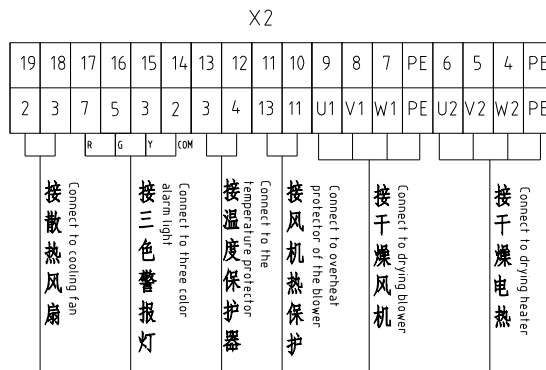

机型版本 Ver.B

					制图	版号	0	标题	SEHD-50-EC	图号	SEHD-50-EC-CE-400V-0-3	比例	第 3 张
					设计	核 准		SHINI 信易電熱機械股份有限公司 Shini Plastics Technologies, Inc.		标准	CE	共 5 张	
标记	更改前	更改后	更改人	日期	审核		日期		2024.03.13	机器电压	3φ400V	机器频率	50Hz

1

2

3

4

5

6

7

8

### 信易辅机RS-485通讯接线示意图

Shini auxiliary machine RS-485 comm. wiring diagram

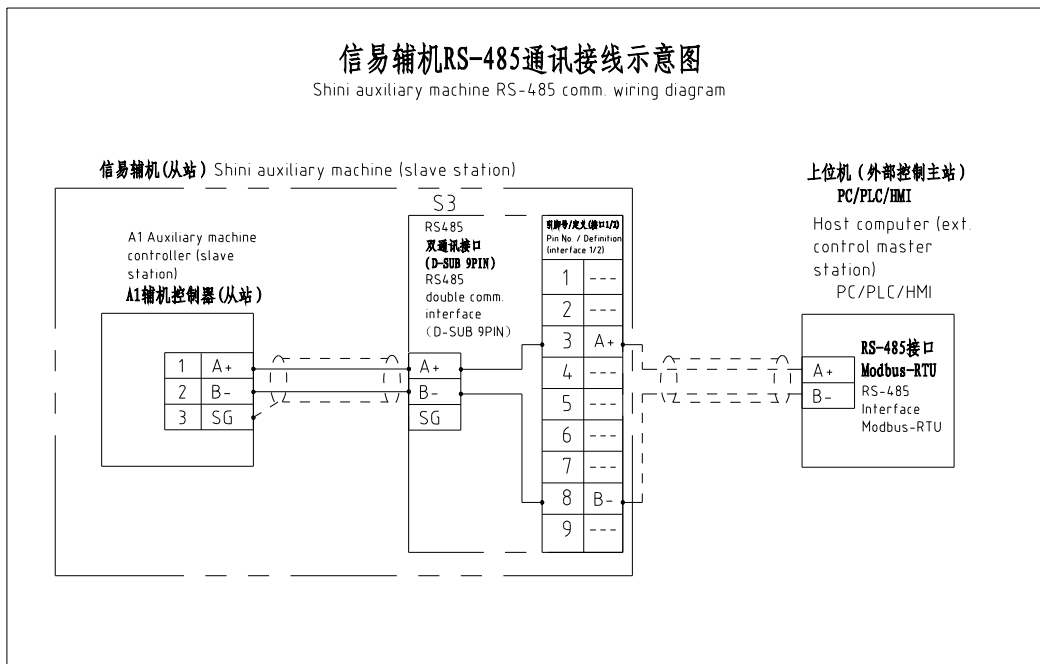

### 信易RS-485接口定义

Shini RS-485 interface definition

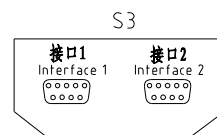

D-sub-9针接口 D-sub-9 pin interface	引脚号 Pin No.	引脚定义 Pin definition
	1	-
	2	-
	3	A+ (RS-485 信号) A+ (RS-485 signal)
	4	-
	5	-
	6	-
	7	-
	8	B- (RS-485 信号) B- (RS-485 signal)
	9	-

- 注: 1. 通讯接口: RS-485 (两线式)  
2. 通讯协议: Modbus-RTU  
3. 机器配备D-sub9母接头, 客户需自备D-sub9公接头;  
4. 接口1和接口2内部并联, 功能相同, 不分主次

Note: 1. Comm. interface: RS-485 (two wire)  
2. Comm. protocol: Modbus-RTU  
3. The machine is equipped with D-sub9 female connector, and the customer needs to provide D-sub9 male connector;  
4. Interface 1 and interface 2 are connected in parallel and have the same function, which is regardless of primary and secondary.

机型版本 Ver.B

						制图	版号	0	标题	SEHD-50-EC	图号	SEHD-50-EC-CE-400V-0-4	比例	第 4 张	
						设计	核 准		通讯接线图		SHINI	信易电热机械股份有限公司 Shini Plastics Technologies, Inc.	标准	CE	共 5 张
						校对							日期	2024.03.13	机器电压
标记	更改前	更改后	更改人	日期	审核	日期	2024.03.13						机器频率	50Hz	

1

2

3

4

5

6

7

8

1		2		3		4		5		6		7		8								
序号/NO	符号/Symbol	名称/Name		制造商/Manufacturer		型号/Type		规格/Specification		单位/unit	数量/Number	物料编号/Material number		备注/Remark								
A	1	Q1 Q2	断路器/Circuit-breaker		TECO		BM-63C/3010S		10A 3P		PCS	2	YE40301003000									
	2		励磁脱扣器/Excitation release		---		MX		24V 50/60Hz		PCS	1	YE40024000000									
	3	Q3	断路器/Circuit-breaker		---		BM-63C/1003S		3A 1P		PCS	1	YE40100203000									
	4	K1	接触器/Contactor		SIEMENS		3RT6016-1AB01		24V 50/60Hz		PCS	1	YE00601602500									
	5	K2 K3	固态继电器/Solid state relay		FOTEK		KSR-40DA-H		40A/480VAC/4-32VDC		PCS	2	YE03404003200									
	6	K4	中间继电器/Middle Relay		HONEYWELL		CR-2C-AC24V底座 base PGR-2C-T		AC24V 50/60Hz		PCS	1	YE00224200100									
	7	T	变压器/Sensor Transformer		JIUXIN		IN=400V/415V OUT=24V		80VA		PCS	1	YE70040006500									
B	8	A1	节能干燥机控制器 Energy saving dryer controller		PUNP		SF807500A.01		24VAC		PCS	1	YE80807500300									
	9	A2	节能干燥机变频器 Energy saving dryer frequency converter		PUNP		FF178100A.01		600W/400V		PCS	1	YE70178100100									
	10	S3	通信接口板RS-485(双Dsub-9pin-接头) Communication interface board RS-485 (double Dsub-9pin connector)		YUYUN		---		---		PCS	1	YE90048501200									
	11		外壳RS485(SAL-700G-A-19)0版 Shell RS485(SAL-700G-A-19)0		BINGCHEN		---		---		PCS	1	YR40048500000									
	12	X1	弹簧接线端子SE2.5(霍尼韦尔) Spring wiring terminal SE2.5(honeywell)		HONEYWELL		SK2.5		2.5mm <sup>2</sup>		PCS	19	YE60002503200									
	13		接地端子GE2.5(霍尼韦尔) Grounding terminal GE2.5(honeywell)		HONEYWELL		GK2.5SPE		2.5mm <sup>2</sup> PE		PCS	3	YE60002503400									
	14	H1	三色警报灯/3-color alarm lamp		SHINI		SWI-P		24V AC/DC		PCS	1	BL90002401520									
C	15		终端固定件E/GK系列(霍尼韦尔) Terminal fittings E/GK series (honeywell)		HONEYWELL		---		---		PCS	5	YE60000003900									
	16	FM	风扇/Fan		----		----		----		----	1	----		(1)							
	17	S1	温度保护器/Overheat protector		----		----		130 °C		----	1	----		(1)							
	18	S2	热电偶/Thermocouple		----		K Type		----		----	2	----		(1)							
	19	M1	风机/Blower		----		----		460V 50Hz		----	1	----		(1)							
	20	EH1	电热/Heater		----		----		460V 50Hz		----	1	----		(1)							
	Notes: (1)Means it's not the material inside the control box. 注: (1)表示非电控箱内材料																					
机型版本 Ver.B																						
D					制图		版号		0		标题		SEHD-50-EC		图号		SEHD-50-EC-CE-400V-0-5		比例		第 5 张	
					设计		核				电气元件明细表一				标准		CE				共 5 张	
					校对		准				 <b>信易電熱機械股份有限公司</b> <b>Shini Plastics Technologies, Inc.</b>		机器电压		3φ400V							
	标记		更改前		更改后		更改人		日期				2024.03.13		机器频率		50Hz					
1		2		3		4		5		6		7		8								

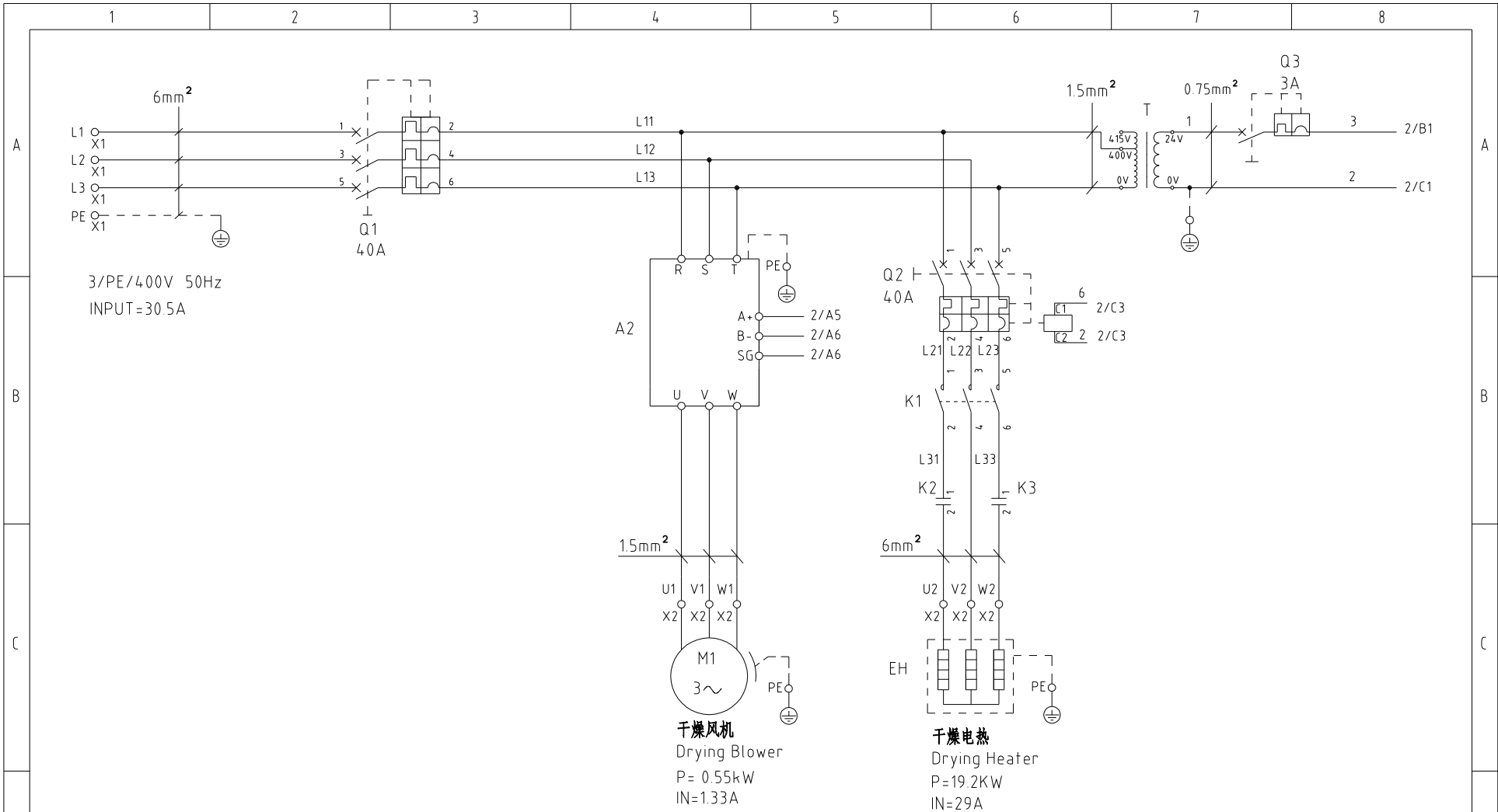

干燥风机  
Drying Blower  
P=0.55kW  
IN=1.33A

干燥电热  
Drying Heater  
P=19.2KW  
IN=29A

机型版本 Ver.B

				制图	版号	0	标题	SEHD-500-EC	图号	SEHD-500-EC-CE-400V-0-1	比例	第 1 张
				设计	核		主电路图		标准	CE	共 5 张	
				校对	准		 <b>信易电热机械股份有限公司</b> <b>Shini Plastics Technologies, Inc.</b>	机器电压	3φ400V			
标记	更改前	更改后	更改人	日期	审核	日期		20240920	机器频率	50Hz		

1                      2                      3                      4                      5                      6                      7                      8

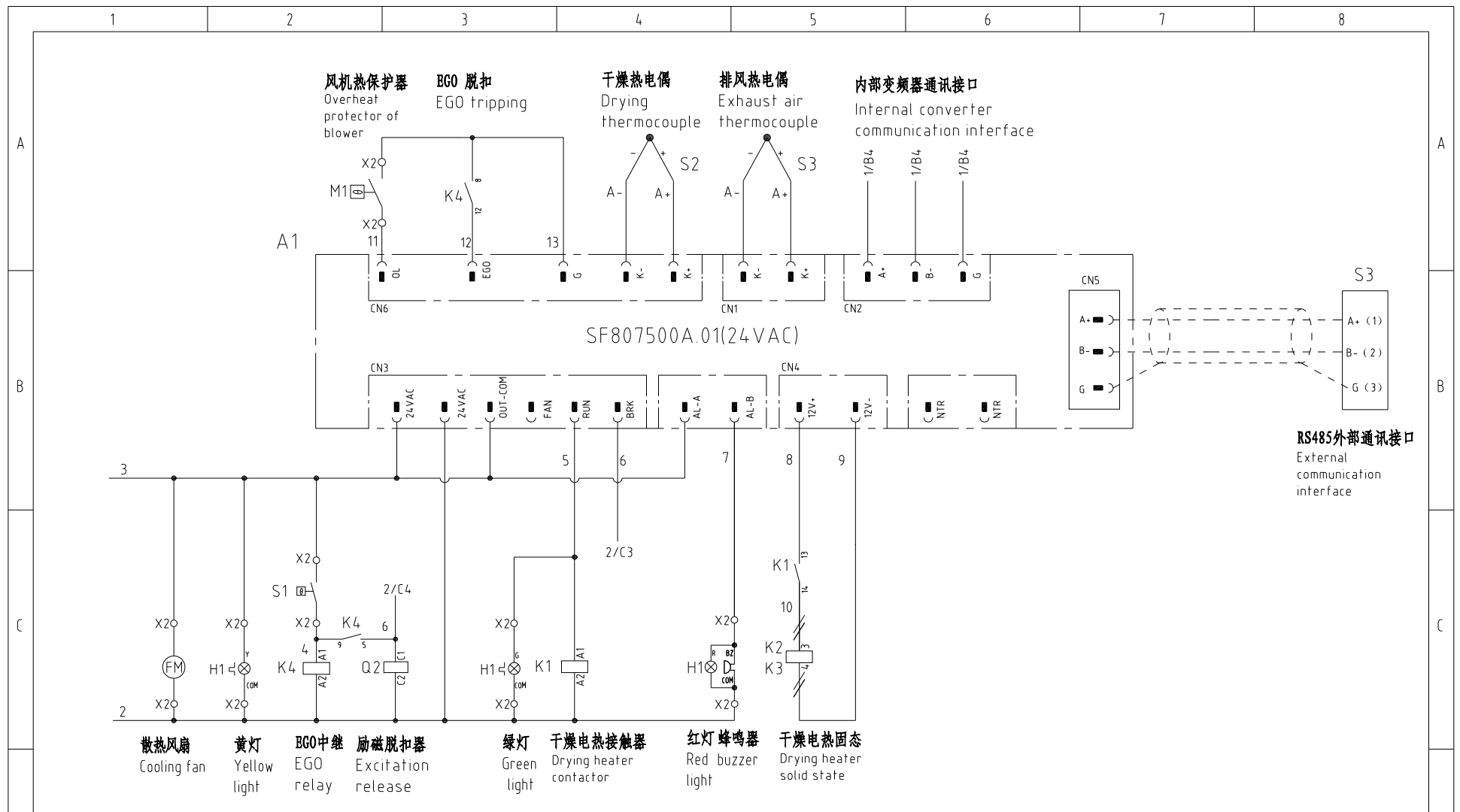

- 3  
散热风扇  
Cooling fan
- 2  
黄灯  
Yellow light
- X2  
BGO中继  
EGO relay
- X2  
励磁脱扣器  
Excitation release
- X2  
绿灯  
Green light
- X2  
干燥电热接触器  
Drying heater contactor
- X2  
红灯蜂鸣器  
Red buzzer light
- X2  
干燥电热固态  
Drying heater solid state

机型版本 Ver.B					制图	版号	0	标题	SEHD-500-EC	图号	SEHD-500-EC-CE-400V-0-2	比例	第 2 张
					设计	核	准	控制电路图		标准	CE	共 5 张	
标记	更改前	更改后	更改人	日期	审核	日期	20240920	<b>信易电热机械股份有限公司</b> Shini Plastics Technologies, Inc.		机器电压	3φ400V	机器频率	50Hz





## 信易辅机RS-485通讯接线示意图

Shini auxiliary machine RS-485 comm. wiring diagram

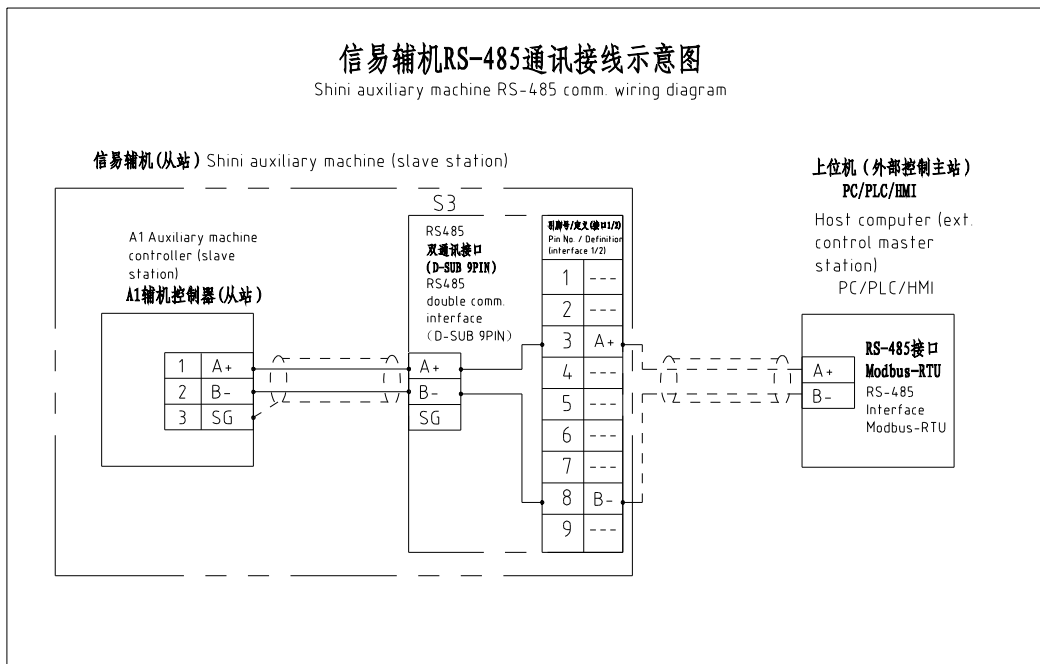

### 信易RS-485接口定义

Shini RS-485 interface definition

S3

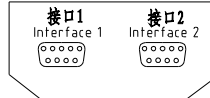

D-sub-9针接口 D-sub-9 pin interface	引脚号 Pin No.	引脚定义 Pin definition
	1	-
	2	-
	3	A+ (RS-485 信号) A+ (RS-485 signal)
	4	-
	5	-
	6	-
	7	-
	8	B- (RS-485 信号) B- (RS-485 signal)
	9	-

- 注: 1. 通讯接口: RS-485 (两线式)  
2. 通讯协议: Modbus-RTU  
3. 机器配备D-sub9母接头, 客户需自备D-sub9公接头;  
4. 接口1和接口2内部并联, 功能相同, 不分主次

Note: 1 Comm. interface: RS-485 (two wire)  
2 Comm. protocol: Modbus-RTU  
3 The machine is equipped with D-sub9 female connector, and the customer needs to provide D-sub9 male connector.  
4. Interface 1 and interface 2 are connected in parallel and have the same function, which is regardless of primary and secondary.

机型版本 Ver.B

						制图	版号	0	标题	SEHD-500-EC	图号	SEHD-500-EC-CE-400V-0-4	比例	第 4 张
						设计	核 准		通讯接线图		标准	CE	机器电压	3φ400V
						校对								
标记	更改前	更改后	更改人	日期	审核	日期	20240920	信易電熱機械股份有限公司 Shini Plastics Technologies, Inc.		机器频率	50Hz			

1

2

3

4

5

6

7

8

1		2		3		4		5		6		7		8									
序号/NO	符号/Symbol	名称/Name		制造商/Manufacturer		型号/Type		规格/Specification		单位/unit	数量/Number	物料编号/Material number		备注/Remark									
A	1	Q1 Q2	断路器/Circuit-breaker		TECO		BM-63C/3040S		40A 3P		PCS	2	YE40304003000										
	2		励磁脱扣器/Excitation release		---		MX		24V 50/60Hz		PCS	1	YE40024000000										
	3	Q3	断路器/Circuit-breaker		TECO		BM-63C/1003S		3A 1P		PCS	1	YE40100203000										
	4	K1	接触器/Contactor		SIEMENS		3RT6026-1AC20		24V 50/60Hz		PCS	1	YE00602602600										
	5	K2 K3	固态继电器/Solid state relay		FOTEK		KSR-40DA-H		40A/480VAC/4-32VDC		PCS	2	YE03404003200										
	6	K4	中间继电器/Middle Relay		HONEYWELL		CR-2C-AC24V底座 base PGR-2C-T		AC24V 50/60Hz		PCS	1	YE00224200100										
	7	T	变压器/Transformer		JIUXIN		IN=400V/415V OUT=24V		80VA		PCS	1	YE70040006500										
B	8	A1	节能干燥机控制器 Energy saving dryer controller		PUNP		SF807500A.01		24VAC		PCS	1	YE80807500300										
	9	A2	节能干燥机变频器 Energy saving dryer frequency converter		PUNP		FF178100A.01		600W/400V		PCS	1	YE70178100100										
	10	S3	通信接口板RS-485(双芯-4芯线) Communication interface board RS-485 (double two-core four-core connector)		YUYUN		---		---		PCS	1	YE90048501200										
	11		外壳RS485(SAL-700G-A-19)0版 Shell RS485(SAL-700G-A-19)0		BINGCHEN		---		---		PCS	1	YR40048500000										
	12	X1 X2	弹簧接线端子SK4(霍尼韦尔 Spring wiring terminal SK4 (Honeywell)		HONEYWELL		SK4		4mm <sup>2</sup>		PCS	6	YE60000403200										
	13		接地端子SK4PE(霍尼韦尔) Grounding terminal SK4PE(HONEYWELL)		HONEYWELL		GK4PE		4mm <sup>2</sup> PE		PCS	2	YE61041000000										
	14		弹簧接线端子SK2.5(霍尼韦尔) Spring wiring terminal SK2.5(Honeywell)		HONEYWELL		SK2.5		2.5mm <sup>2</sup>		PCS	13	YE60002503200										
15		接地端子GK2.5(霍尼韦尔) Grounding terminal GK2.5(honeywell)		HONEYWELL		GK2.5PE		2.5mm <sup>2</sup> PE		PCS	1	YE60002503400											
C	16	H1	三色警报灯/3-color alarm lamp		SHINI		SWI-P		24V AC/DC		PCS	1	BL90002401520										
	17		终端固定件E/GK系列(霍尼韦尔) Terminal fittings E/GK series (honeywell)		HONEYWELL		---		---		PCS	5	YE60000003900										
	18	FM	风扇/Fan		----		----		----		----	2	----		(1)								
	19	S1	温度保护器/temperature protector		----		----		130 °C		----	1	----		(1)								
	20	S2	热电偶/Thermocouple		----		K Type		----		----	2	----		(1)								
	21	M1	风机/Blower		----		----		400V 50Hz		----	1	----		(1)								
	22	EH1	电热/Heater		----		----		400V 50Hz		----	1	----		(1)								
D	机型版本 Ver.B																						
					制图		版号		0		标题		SEHD-500-EC		图号		SEHD-500-EC-CE-400V-0-5		比例		第 5 张		
					设计		核				电气元件明细表一				标准		CE				共 5 张		
	标记		更改前		更改后		更改人		日期		审核		日期		20240920				信易电热机械股份有限公司 Shini Plastics Technologies, Inc.		机器电压		3φ400V
																		机器频率		50Hz			

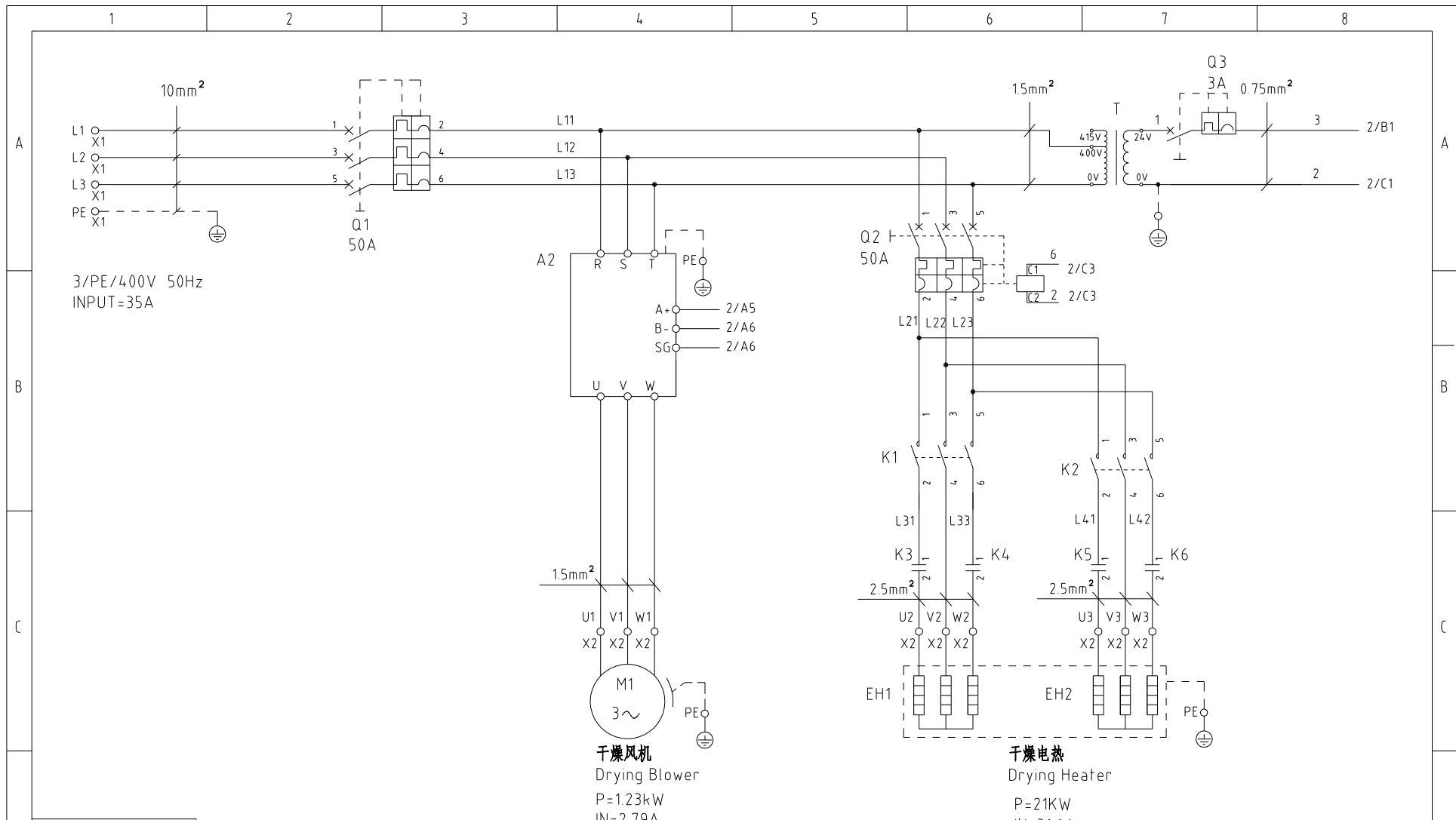

机型版本 Ver.B

D						制图	版号	0	标题	SHD-600E-EC	图号	SHD-600E-EC-CE-400V-0-1	比例	第 1 张
						设计	核		主电路图		标准	CE	共 5 张	
						校对	准		 <b>信易电热机械股份有限公司</b> <b>Shini Plastics Technologies, Inc.</b>	机器电压	3φ400V			
	标记	更改前	更改后	更改人	日期	审核	日期	2024.0118		机器频率	50Hz			

1 2 3 4 5 6 7 8

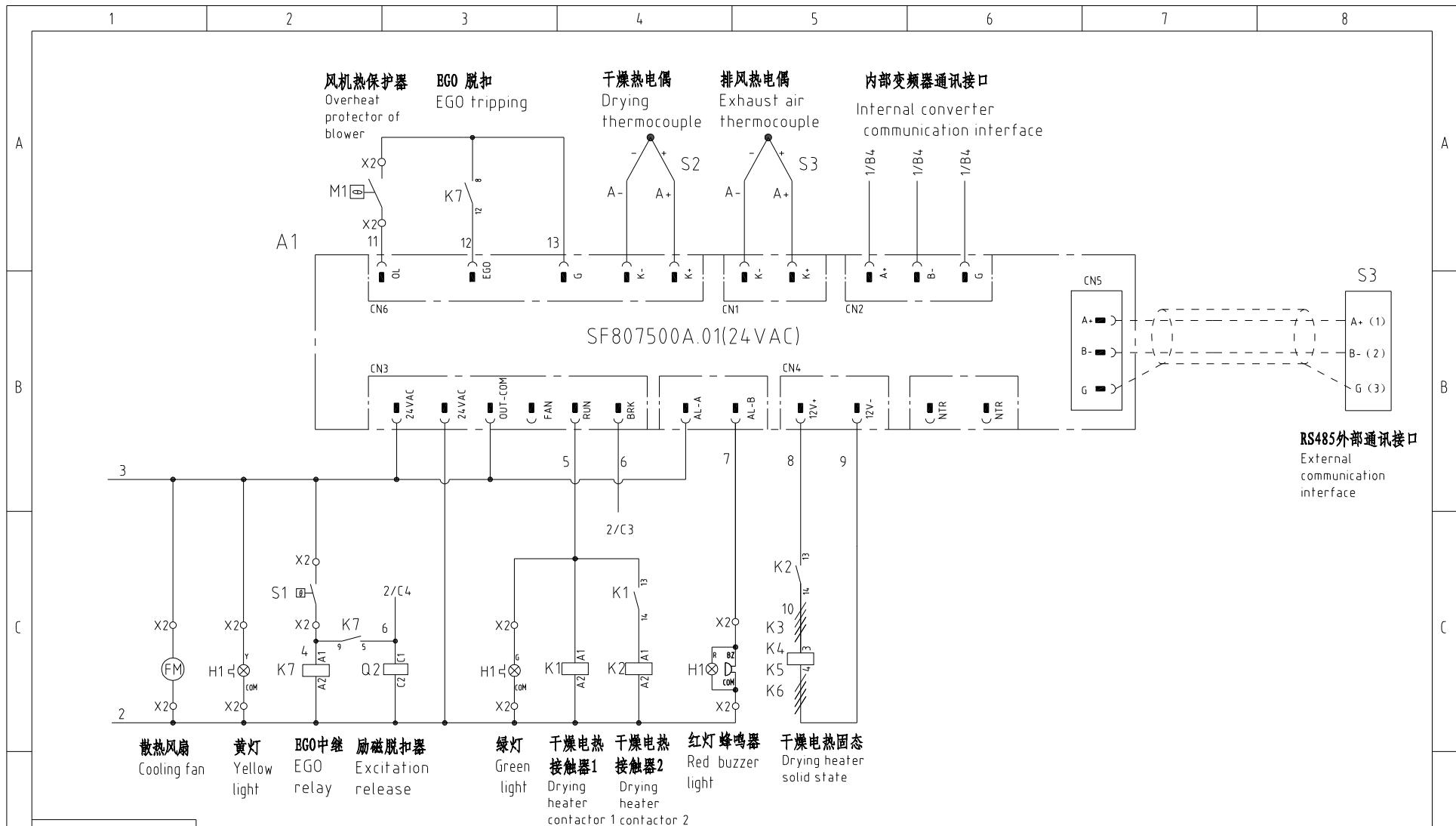

- 散热风扇  
Cooling fan
- 黄灯  
Yellow light
- EGO中继  
EGO relay
- 励磁脱扣器  
Excitation release
- 绿灯  
Green light
- 干燥电热接触器1  
Drying heater contactor 1
- 干燥电热接触器2  
Drying heater contactor 2
- 红灯蜂鸣器  
Red buzzer light
- 干燥电热固态  
Drying heater solid state

机型版本 Ver.B					制图	版号	0	标题	SHD-600E-EC	图号	SHD-600E-EC-CE-400V-0-2	比例	第 2 张
					设计	核		控制电路图		标准	CE	共 5 张	
					校对	准		<b>信易电热机械股份有限公司</b> <b>Shini Plastics Technologies, Inc.</b>	机器电压	3φ400V			
标记	更改前	更改后	更改人	日期	审核	日期	2024.0118		机器频率	50Hz			

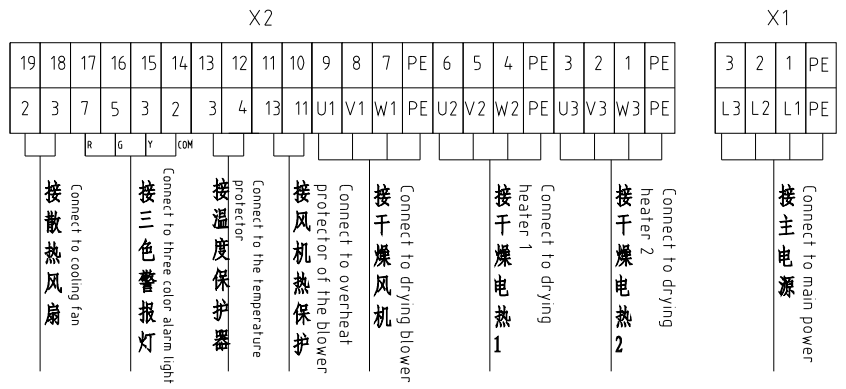
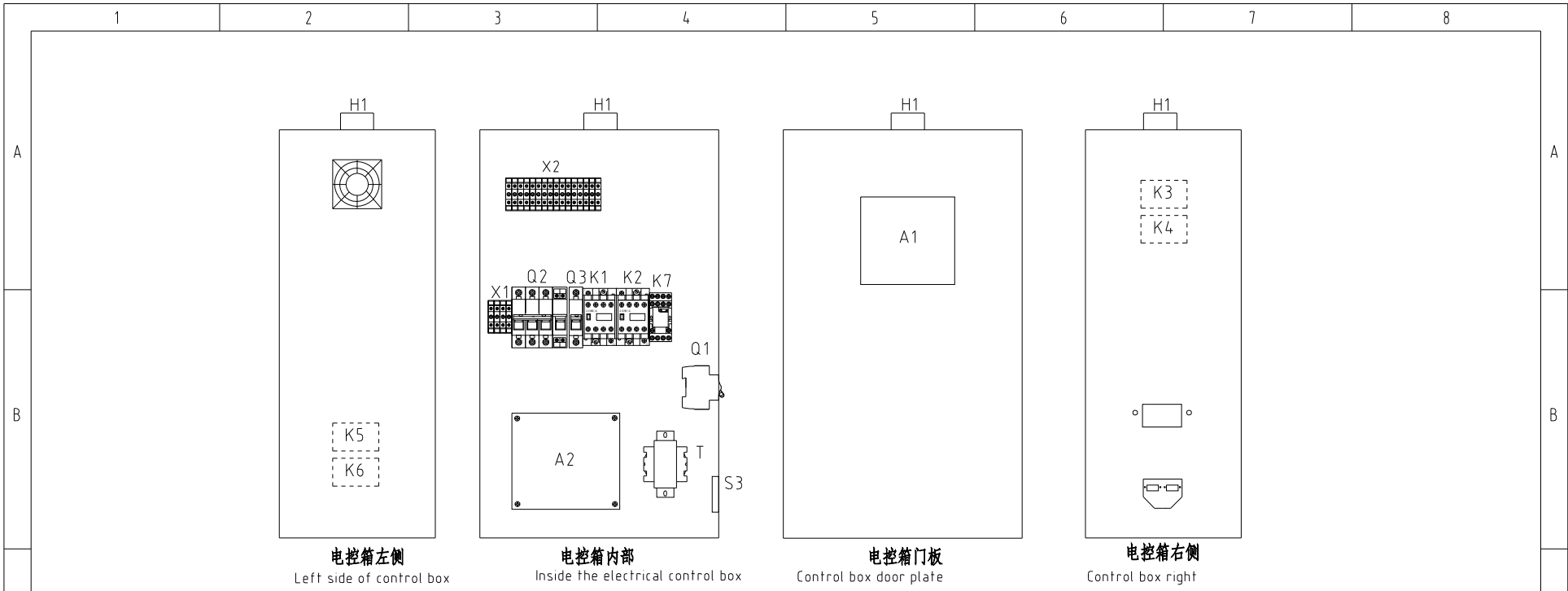

机型版本 Ver.B				制图		版号 0		标题 SHD-600E-EC		图号 SHD-600E-EC-CE-400V-0-3		比例		第 3 张	
				设计		核准		电气元件布置及端子接线图		标准 CE		机器电压 3φ400V		共 5 张	
				校对		日期 2024.0118		 <b>信易电热机械股份有限公司</b> <b>Shini Plastics Technologies, Inc.</b>		机器频率 50Hz					
标记	更改前	更改后	更改人	日期	审核	日期									

## 信易辅机RS-485通讯接线示意图

Shini auxiliary machine RS-485 comm. wiring diagram

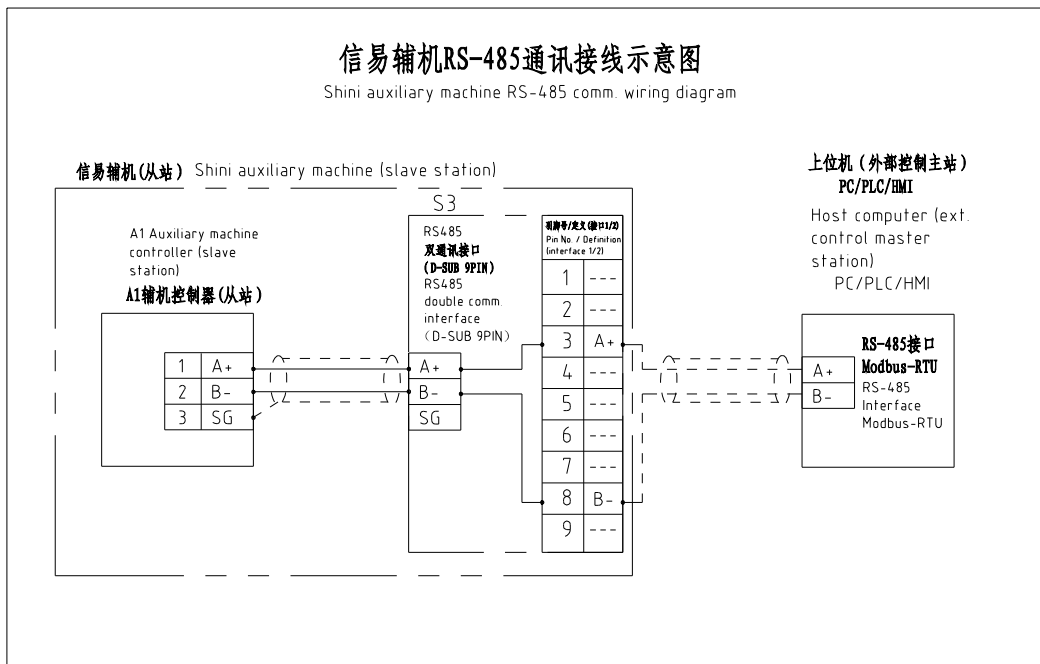

### 信易RS-485接口定义

Shini RS-485 interface definition

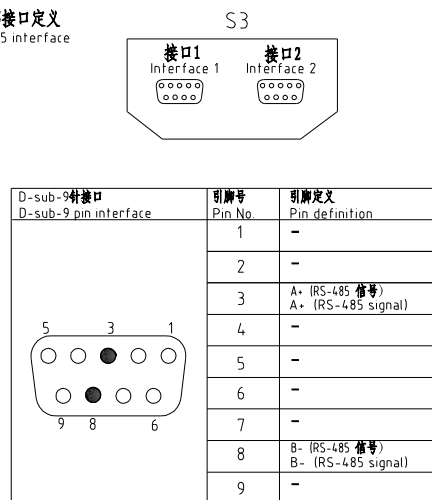

- 注: 1. 通讯接口: RS-485 (两线式)  
2. 通讯协议: Modbus-RTU  
3. 机器配备D-sub9母接头, 客户需自备D-sub9公接头;  
4. 接口1和接口2内部并联, 功能相同, 不分主次

Note: 1. Comm. interface: RS-485 (two wire)  
2. Comm. protocol: Modbus-RTU  
3. The machine is equipped with D-sub9 female connector, and the customer needs to provide D-sub9 male connector;  
4. Interface 1 and interface 2 are connected in parallel and have the same function, which is regardless of primary and secondary

机型版本 Ver.B

制图		版号		0		标题		SHD-600E-EC		图号		SHD-600E-EC-CE-400V-0-4		比例		第 4 张	
设计		核准				通讯接线图				标准		CE		共 5 张			
校对		审核		日期		2024.0118		SHINI		信易电热机械股份有限公司		Shini Plastics Technologies, Inc.		机器电压		3φ400V	
标记		更改前		更改后		更改人		日期		机器频率		50Hz					

1

2

3

4

5

6

7

8

1		2		3		4		5		6		7		8									
序号/NO	符号/Symbol	名称/Name		制造商/Manufacturer		型号/Type		规格/Specification		单位/unit	数量/Number	物料编号/Material number		备注/Remark									
A	1	Q1 Q2	断路器/Circuit-breaker		TECO		BM-63C/3050S		50A 3P		PCS	2	YE40305003000										
	2		励磁脱扣器/Excitation release		---		MX		24V 50/60Hz		PCS	1	YE40024000000										
	3	Q3	断路器/Circuit-breaker		TECO		BM-63C/1003S		3A 1P		PCS	1	YE40100203000										
	4	K1 K2	接触器/Contactor		SIEMENS		3RT6023-1AC20		24V 50/60Hz		PCS	2	YE00602301100										
	5	K3 K4 K5 K6	固态继电器/Solid state relay		FOTEK		KSR-40DA-H		40A/480VAC/4-32VDC		PCS	4	YE03404003200										
	6	K7	中间继电器/Middle Relay		HONEYWELL		CR-2C-AC24V底座 base PGR-2C-T		AC24V 50/60Hz		PCS	1	YE00224200100										
	7	T	变压器/Transformer		JIUXIN		IN=400V/415V OUT=24V		80VA		PCS	1	YE70040006500										
B	8	A1	节能乾燥機控制器 Energy saving dryer controller		PUNP		SF807500A.01		24VAC		PCS	1	YE80807500300										
	9	A2	节能乾燥機变频器 Energy saving dryer frequency converter		PUNP		FX205000A.01-1		1.5KW/400V		PCS	1	YE70205000100										
	10	S3	通信接口板RS-485 (通信接口板 RS-485 (双端-双端连接器))		YUYUN		---		---		PCS	1	YE90048501200										
	11		外壳RS485 (SAL-700G-A-19)0版 Shell RS485 (SAL-700G-A-19)0		BINGCHEN		---		---		PCS	1	YR40048500000										
	12	X1 X2	弹簧接线端子 Spring wiring terminal		HONEYWELL		GK10		10mm <sup>2</sup>		PCS	3	YE60001003200										
	13		接地端子 Grounding terminal		HONEYWELL		GK10PE		10mm <sup>2</sup> PE		PCS	1	YE60001003500										
	14		弹簧接线端子 Spring wiring terminal		HONEYWELL		SK2.5		2.5mm <sup>2</sup>		PCS	19	YE60002503200										
C	15		接地端子 Grounding terminal		HONEYWELL		SK2.5PE		2.5mm <sup>2</sup> PE		PCS	3	YE60002503400										
	16	H1	三色警报灯/Three color alarm lamp		SHINI		SWI-P		24V AC/DC		PCS	1	BL90002401520										
	17		终端固定件E/GK系列 (霍尼韦尔) Terminal fittings E/GK series (honeywell)		HONEYWELL		---		---		PCS	6	YE60000003900										
	18	FM	风扇/Fan		----		----		----			1	----		(1)								
	19	S1	温度保护器/Overheat protector		----		----		130 °C			1	----		(1)								
	20	S2	热电偶/Thermocouple		----		K Type		----			2	----		(1)								
	21	M1	风机/Blower		----		----		400V 50HZ			1	----		(1)								
	22	EH1	电热/Heater		----		----		400V 50HZ			2	----		(1)								
D	Notes: (1)Means it's not the material inside the control box.																						
	机型版本 Ver.B		注: (1)表示非电控箱内材料																				
					制图		版号		0		标题		SHD-600E-EC		图号		SHD-600E-EC-CE-400V-0-5		比例		第 5 张		
					设计		核准				电气元件明细表一				标准		CE		共 5 张				
标记		更改前		更改后		更改人		日期		审核		日期		2024.0118				信易電熱機械股份有限公司 Shini Plastics Technologies, Inc.		机器电压		3φ400V	
																		机器频率		50Hz			
1		2		3		4		5		6		7		8									