

SHD-U-HD

Heatless Dehumidifying Hot-air Dryer

Date: Apr. 2014

Version: Ver.C (English)



Contents

1. General Description	7
1.1 Coding Principle	8
1.2 Feature.....	8
1.3 Technical Specifications.....	10
1.3.1 Specifications	10
1.3.2 Technical Specifications	10
1.4 Safety Regulations	11
1.4.1 Safety Signs and Labels.....	11
1.4.2 Signs and Labels	11
1.5 Exemption Clause	11
2. Structure Characteristics and Working Principle	13
2.1 Working Principle	13
2.2 Drawing and Parts List	14
2.2.1 Structural Drawing	14
2.2.2 Assembly Drawing.....	15
2.2.3 Parts List (SHD-40U~120U-HD).....	16
2.2.4 Assembly Drawing of Drying	17
2.2.5 Parts & Materials List of Dry Charging Barrel (SHD-40U~120U-HD).....	18
2.2.6 Parts Drawing of Hot-air Recycler	19
2.2.7 Parts & Materials List of Hot-air Recycler (SHD-40U~120U-HD)	20
2.3 Electrical Diagram	21
2.3.1 Electrical Diagram (SHD-40U~120U-HD).....	21
2.3.2 Main Circuit (SHD-40U~120U-HD).....	22
2.3.3 Control Circuit (SHD-40U~120U-HD)	23
2.3.4 Thermocouple and Terminal Layout (SHD-40U~120U-HD)	24
2.3.5 Components Layout (SHD-40U~120U-HD).....	25
2.3.6 Electrical Components List (SHD-40U~120U-HD)	26
2.3.7 Main Electrical Components Description	28
2.4 Optional Accessories	29
2.4.1 Floor Stand	29

2.4.2	Pneumatic Shut-off Valve and Suction Box	29
3.	Installation and Debugging.....	31
3.1	Attentions during Installation:	31
3.2	Installation Reference	31
3.2.1	Install directly on a moulding machine.....	31
3.2.2	To be Used with Hopper Loaders	31
3.3	Power Supply	32
4.	Application and Operation.....	33
4.1	Description of Control Panel	33
4.2	Operation of the Machine.....	33
4.3	Temperature Setting	33
4.4	Intermittent Drying Setting.....	33
4.5	Weekly Time Start Setup	35
4.6	System Clock Adjustment	37
4.7	Enable One-week Automatic Start / Stop Timer.....	37
4.8	Lock up the Machine	37
4.9	Meaning of Error Code.....	38
5.	Trouble shooting	39
6.	Maintenance and Repair	40
6.1	Hot-air Recycler	40
6.1.1	Exhaust-air Filter	41
6.2	GXW/GW Athermal Regeneration Type of Air Dryer.....	41
6.2.1	Operation Instruction	42
6.2.2	Model and Specification	42
6.2.3	Technical Parameter	43
6.2.4	Maintenance	43
6.3	Blower	49
6.4	Maintenance Schedule.....	49
6.4.1	About the Machine.....	49
6.4.2	Installation & Inspection.....	49
6.4.3	Daily Checking.....	49
6.4.4	Weekly Checking.....	49
6.4.5	Monthly Checking	49

6.4.6 Half-yearly Checking	50
----------------------------------	----

Form Index

Chart 1-1: Specifications	10
Chart 2-1: Parts List (SHD-40U~120U-HD).....	16
Chart 2-2: Parts & Materials List of Dry Charging Barrel (SHD-40U~120U-HD)	18
Chart 2-3: Parts & Materials List of Hot-air Recycler (SHD-40U~120U-HD) ...	20
Chart 2-4: Electrical Diagram (SHD-40U~120U-HD)	21
Chart 2-5: Electrical Components List (SHD-40U-HD).....	26
Chart 2-6: Electrical Components List (SHD-80U/120U-HD)	27
Chart 4-1: Meaning of Error Code.....	38

Picture Index

Picture 1-1: SHD-U-HD (With Optional Floor Stand).....	10
Picture 2-1: Working Principle.....	13
Picture 2-2: Structural Drawing	14
Picture 2-3: Assembly Drawing	15
Picture 2-4: Assembly Drawing of Drying Drying.....	17
Picture 2-5: Main Circuit (SHD-40U~120U-HD)	22
Picture 2-6: Control Circuit (SHD-40U~120U-HD)	23
Picture 2-7: Thermocouple and Terminal Layout (SHD-40U~120U-HD).....	24
Picture 2-8: Components Layout (SHD-40U~120U-HD)	25
Picture 2-9: Overload Relay	28
Picture 2-10: Pneumatic Shut-off Valve and Suction Box	30
Picture 3-1: Installation Scheme of Injection Molding Machine	31
Picture 3-2: Installation Scheme of Receiver Hopper.....	32
Picture 4-1: Intermittent Drying Setting-Chart 1.....	34
Picture 4-2: Intermittent Drying Setting-Chart 2.....	34
Picture 4-3: Intermittent Drying Setting-Chart 3.....	35
Picture 4-4: One-week Automatic Start / Stop Timer-Chart 1.....	35
Picture 4-5: One-week Automatic Start / Stop Timer-Chart 2.....	35

Picture 4-6: One-week Automatic Start / Stop Timer-Chart 3.....	36
Picture 4-7: One-week Automatic Start / Stop Timer-Chart 4.....	36
Picture 4-8: One-week Automatic Start / Stop Timer-Chart 5.....	37

1. General Description



Read this manual carefully before operation to prevent damage of the machine or personal injuries.

The Heatless Dehumidifying Hot-air Dryer is made of stainless steel and equipped with athermal regeneration type of air dryer, which is able to dry plastic raw materials with stable and low dew-point dry air without heating and regeneration. Features dry air down-flouring and cyclone exhaust and double insulated lager design, suitable for drying hygroscopic engineering plastics which are hard for common hopper dryer. Besides, it is also featured by its low power consumption and short drying time. This series is able to provide machines with three feeding capacities of 40L, 80L and 120L.

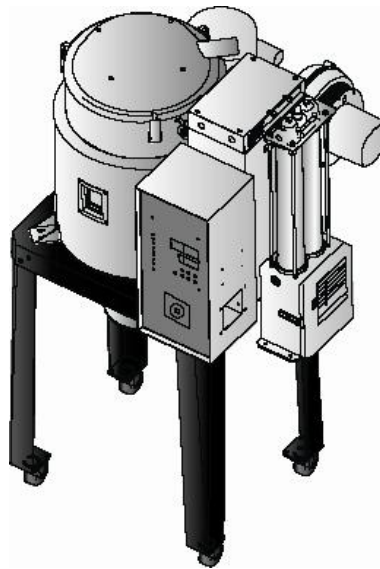

Model: SHD-80U-HD + Floor Stand and Suction Box

1.1 Coding Principle

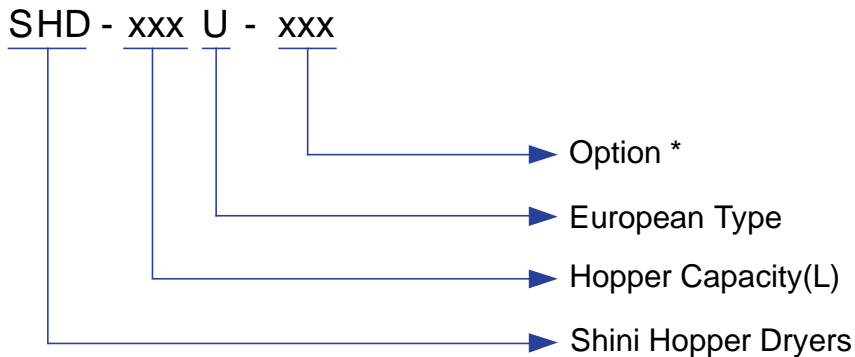

Note: *

P=For Polished Hopper Inside

HD=Heatless Dehumidifying

CE=CE Conformity

1.2 Feature

1) Standard configuration

- Microprocessor is used for accurate temperature control.
- Digital P.I.D. temperature control with LED display.
- Overheat protection to ensure reliable operation.
- 7-day automatic start/stop timer to improve energy saving.
- Unique design of downblow air pipe can spread hot air evenly, keeping plastics dry and temperature stable to raise drying efficiency.
- Models SHD-80U and above have material clearance door to make the clean more convenient and effective.
- SHD-450U and models below are equipped with stainless steel lining aluminium base. SHD-600U~1200U are equipped with aluminium magnetic base. SHD-1500U and model above are equipped with manual butterfly valve.
- For SHD-900U models and above, floor stand is standard equipment.

2) Accessory option

- Cyclone dust separator, exhaust air filter, magnetic base and blower inlet filter are optional.
- Hot air recycler, suction box, hopper magnetic, N type floor stand and storage hopper are optional.
- Safety protective ladder is optional for SHD-1500U and models above.
- SHD-U-HD heatless dehumidifying hot-air dryer, fit with heatless

regenerative device, which can supply dried air with relative low dew-point for speedup materials drying.

- SHD-U-HD heatless dehumidifying hot-air dryer, standard with hot air recyclers, which can save energy effectively. Without dust discharging, which ensures environment protection.

All service work should be carried out by a person with technical training or corresponding professional experience. The manual contains instructions for both handling and servicing. Chapter 7, which contains service instructions intended for service engineers. Other chapters contain instructions for the daily operator.

Any modifications of the machine must be approved by SHINI in order to avoid personal injury and damage to machine. We shall not be liable for any damage caused by unauthorized change of the machine.

Our company provides excellent after-sales service. Should you have any problem during using the machine, please contact the company or the local vendor.

Headquarter and Taipei factory:

Tel: (886) 2 2680 9119

Shini Plastics Technologies (Dongguan), Inc:

Tel: (86) 769 8111 6600

Shini Plastics Technologies India Pvt.Ltd.:

Tel: (91) 250 3021 166

1.3 Technical Specifications

1.3.1 Specifications

Chart 1-1: Specifications

Model	Loading Capacity (L)	Heater Power (kW)	Blower (kW, 50 / 60Hz)	Dimensions (mm) H×W×D	Floor Stand* (mm) H1×W1×D1	Whole Height H2 (mm)	Air Inlet Pipe Dia. ΦA(inch)	Air Outlet Pipe Dia. ΦA(inch)	Weight (kg)
SHD-40U-HD	40	3	0.12	760×790×394	790×580×450	1300	2"	1.5"	70
SHD-80U-HD	80	3.9	0.12	940×885×472	840×730×560	1480	2.5"	2"	85
SHD-120U-HD	120	3.9	0.12	1210×885×472	840×730×560	1740	2.5"	2"	100

- Note: 1) For polished hopper inside, plus "P" at model behind.
 2) Net weight of machine includes floor stand.
 3) Items marked with "*" are for selective pairing.
 4) Power supply: 3Φ, 230 / 400 / 460 / 575V, 50 / 60Hz.

We reserve the right to change specifications without prior notice.

1.3.2 Technical Specifications

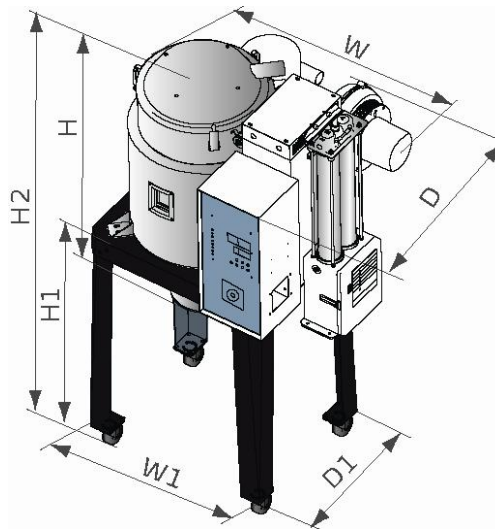

Picture 1-1: SHD-U-HD (With Optional Floor Stand)

1.4 Safety Regulations



Note!

Electrical installation should be done by qualified electrician only. Before connecting to AC Power Source, turn power switch to OFF position. While AC power source is connected, make sure specifications and overload protection rating of the power switch are suitable and reliable. When the machine is under care or maintenance, turn off both power switch and automatic operation switch.

1.4.1 Safety Signs and Labels



Danger!
High Voltage!
It is attached to the control box.



Attention!
This mark reminds you to be more careful.



Warning!
High temperature surface may burn hands!
This label should be stick to the shell of electric heating box.



Attention!
No need for regular inspection because all the electrical parts in the control unit are fixed tightly!

1.4.2 Signs and Labels

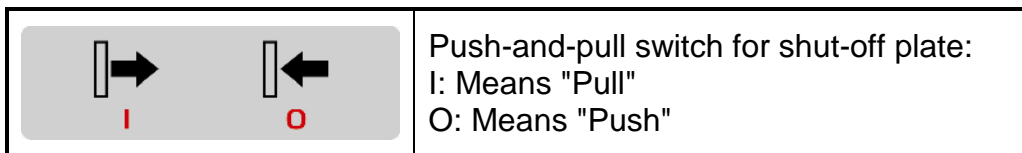

1.5 Exemption Clause

The following statements clarify the responsibilities and regulations born by any buyer or user who purchases products and accessories from Shini (including employees and agents).

Shini is exempted from liability for any costs, fees, claims and losses caused by reasons below:

1. Any careless or man-made installations, operation and maintenances upon machines without referring to the Manual prior to machine using.
2. Any incidents beyond human reasonable controls, which include man-made vicious or deliberate damages or abnormal power, and machine faults caused by irresistible natural disasters including fire, flood, storm and earthquake.
3. Any operational actions that are not authorized by Shini upon machine, including adding or replacing accessories, dismantling, delivering or repairing.
4. Employing consumables or oil media that are not appointed by Shini.

2. Structure Characteristics and Working Principle

2.1 Working Principle

Air blown out of drying blower became high temperature drying air after being heated. Through screen protector and hole screen, hot air can be equably dispersed in the material of storage tank (See the picture). HAR is optional so the air enter drying blower after being filtered to form a closed loop circle.

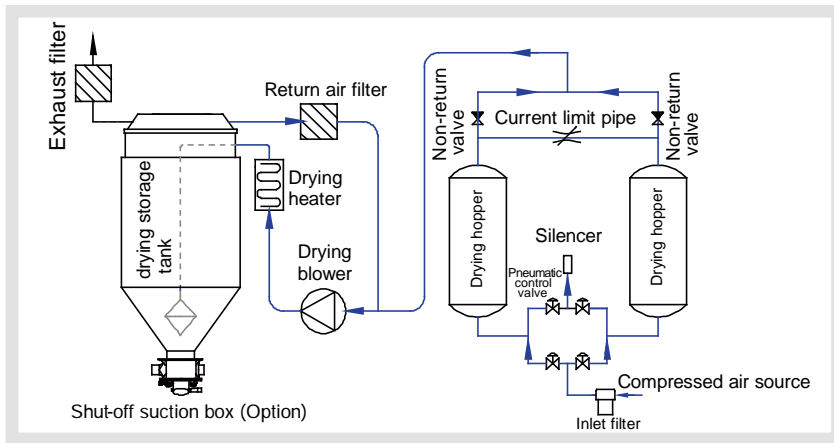

Picture 2-1: Working Principle

2.2 Drawing and Parts List

2.2.1 Structural Drawing

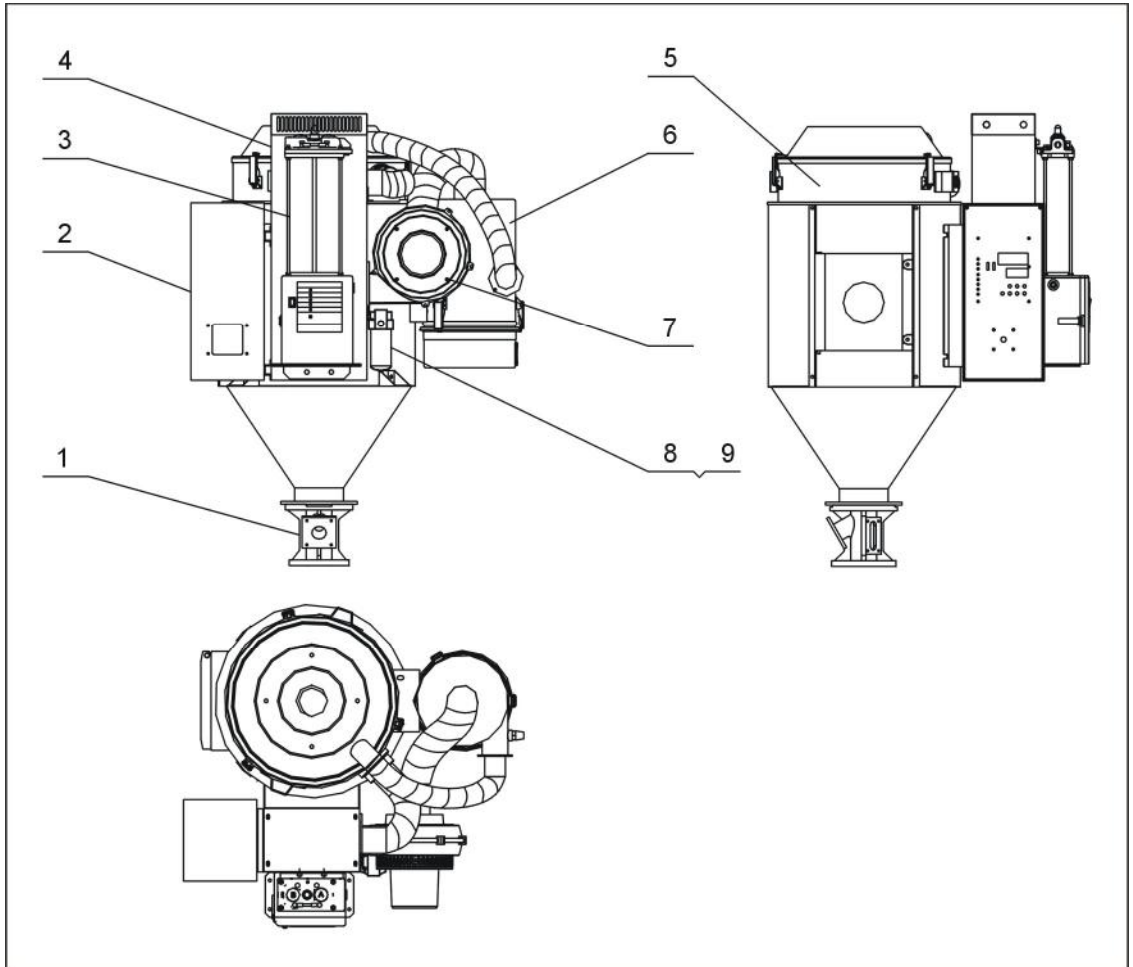

Names of Parts:

- | | | |
|------------------|--------------------------|--|
| 1. Standard base | 2. Control box | 3. Athermal regeneration type of air dryer |
| 4. Heating case | 5. Drying tank | 6. Hot-air Recycler |
| 7. Drying blower | 8. Inlet oil mist filter | 9. Solenoid valve |

Picture 2-2: Structural Drawing

2.2.2 Assembly Drawing

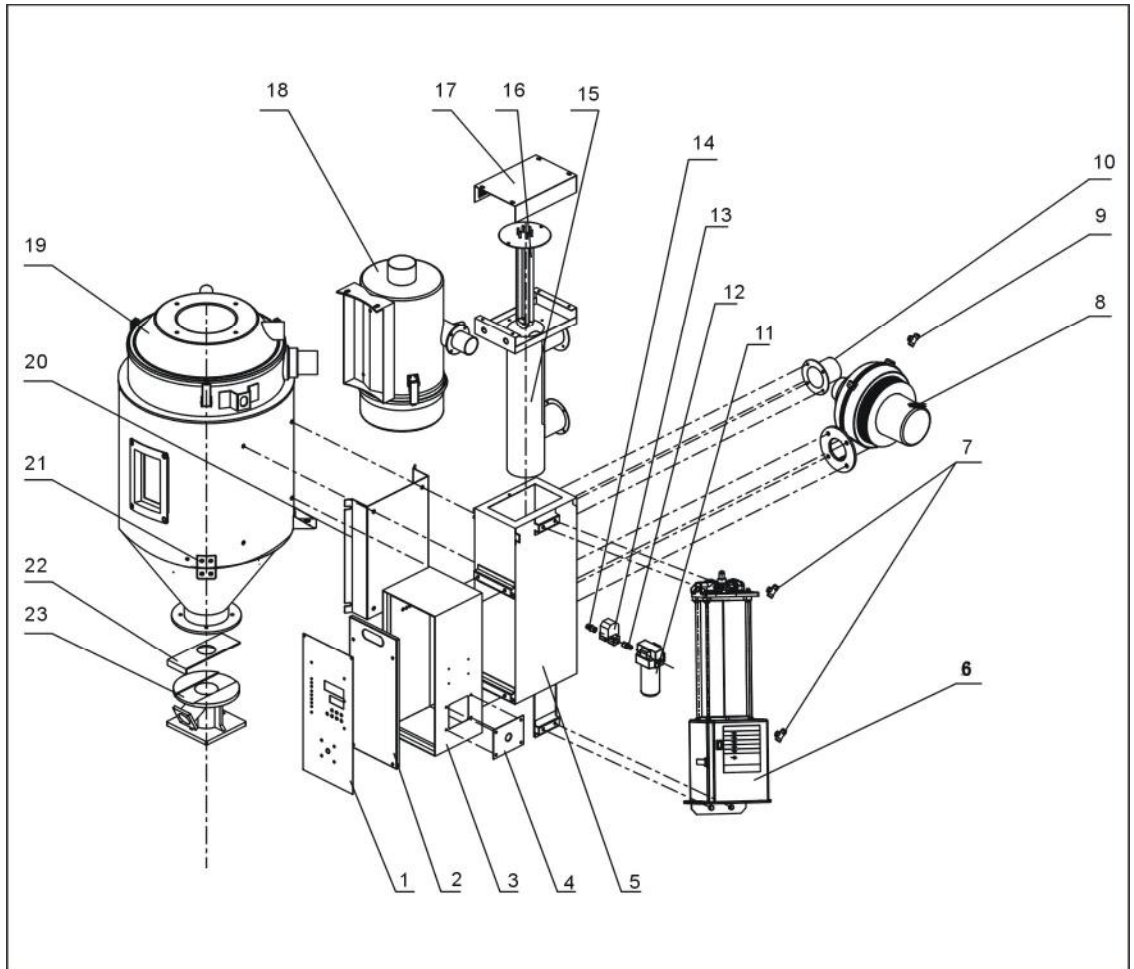

Remarks: Please refer to Material List 2.2.3 for specific explanation of the Arabic numbers in Parts Drawing.

Picture 2-3: Assembly Drawing

2.2.3 Parts List (SHD-40U~120U-HD)

Chart 2-1: Parts List (SHD-40U~120U-HD)

No.	Name	Part No.		
		SHD-40U-HD	SHD-80U-HD	SHD-120U-HD
1	Control cabinet door	-	-	-
2	Base plate of control box	-	-	-
3	Control cabinet body	-	-	-
4	Wire fixture's setting plate	-	-	-
5	Heating case box	-	-	-
6	Athermal regeneration type of dryer	BY90106600050	BY90106600050	BY90206600050
7	Adjustable quick coupling	YW80061400000	YW80061400000	YW80061400000
8	Blower	BM40002500350	BM40002500250	BM40002500350
9	Air pipe coupling	YW80061400200	YW80061400200	YW80061400200
10	Fan inlet flange	-	-	-
11	Filter	YR50300310000	YR50300310000	YR50300310000
12	Copper adapter	-	-	-
13	Solenoid valve	YE32331000000	YE32331000000	YE32331000000
14	Air pipe coupling	YW80031400000	YW80031400000	YW80031400000
15	Hot air pipe	-	-	-
16	Pipe heater*	BH70400300350	BH70803900250	BH70803900250
17	Hot-air pipe cover	-	-	-
18	Hot-air recycler	-	-	-
19	Drying tank	-	-	-
20	Case setting plate	-	-	-
21	Stiffening rib	-	-	-
22	Shut-off plate	-	-	-
23	Standard base	-	-	-

* means possible broken parts.

** means easy broken part. and spare backup is suggested.

Please confirm the version of manual before placing the purchase order to guarantee that the item number of the spare part is in accordance with the real object.

2.2.4 Assembly Drawing of Drying Hopper

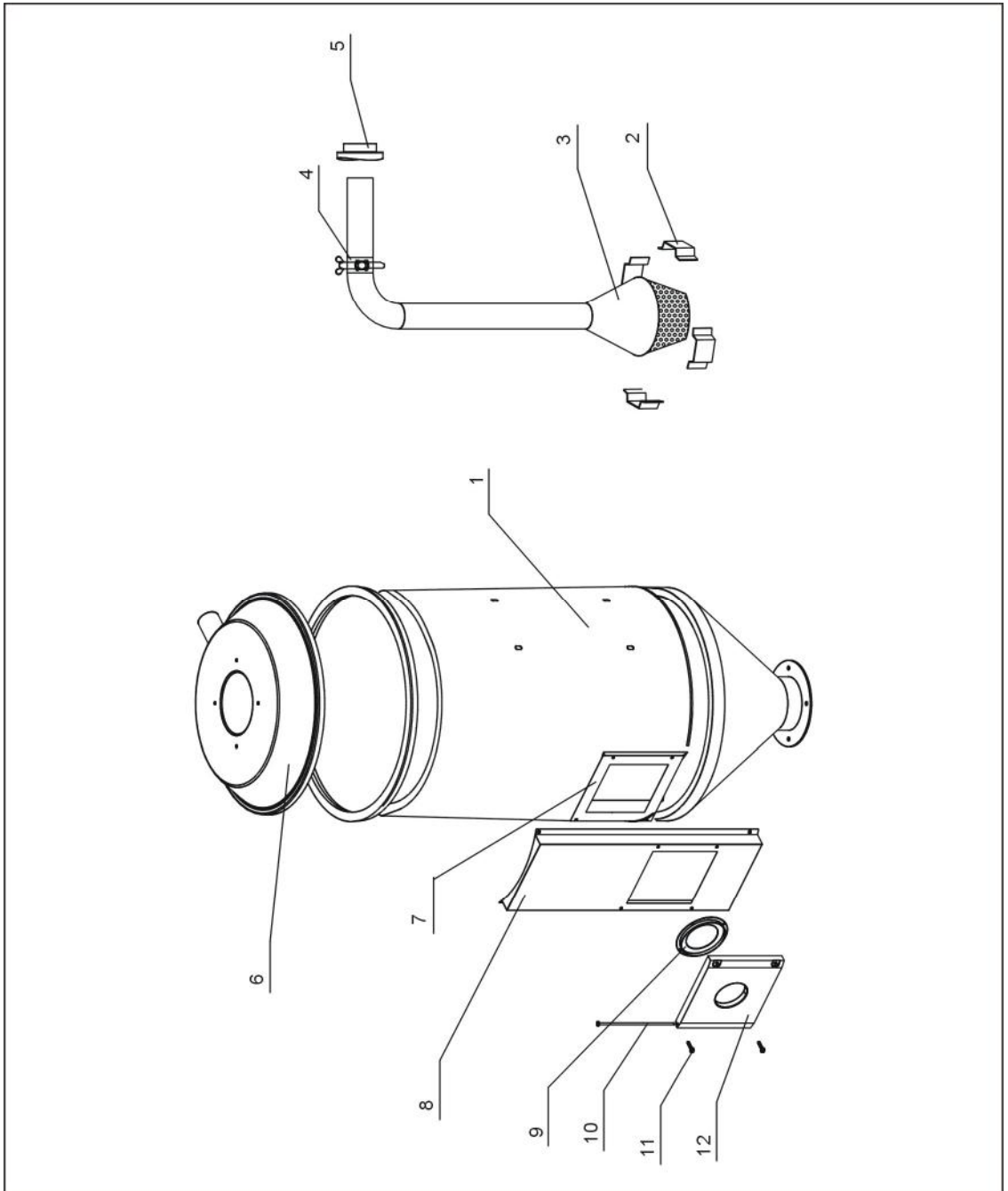

Remarks: Please refer to Material List 2.2.5 for specific explanation of the Arabic numbers in Parts Drawing.

Picture 2-4: Assembly Drawing of Drying Hopper

2.2.5 Parts & Materials List of Dry Charging Barrel (SHD-40U~120U-HD)

Chart 2-2: Parts & Materials List of Dry Charging Barrel (SHD-40U~120U-HD)

No.	Name	Part No.		
		SHD-40U-HD	SHD-80U-HD	SHD-120U-HD
1	Drying Hopper	-	-	-
2	Insider fixed block	-	-	-
3	Down blowing air pipe	-	-	-
4	Stainless steel clamp	YW07000200000	YW07002500600	YW07002500600
5	Down-blowing pipe fixation block	-	-	-
6	Lid	-	-	-
7	Sight glass frame	-	-	-
8	Outer sight-glass frame	-	-	-
9	Charging entrance flange	-	-	-
10	Latch	-	-	-
11	Holding screw	-	-	-
12	Sight glass door	-	-	-

* means possible broken parts.

** means easy broken part. and spare backup is suggested.

Please confirm the version of manual before placing the purchase order to guarantee that the item number of the spare part is in accordance with the real object.

2.2.6 Parts Drawing of Hot-air Recycler

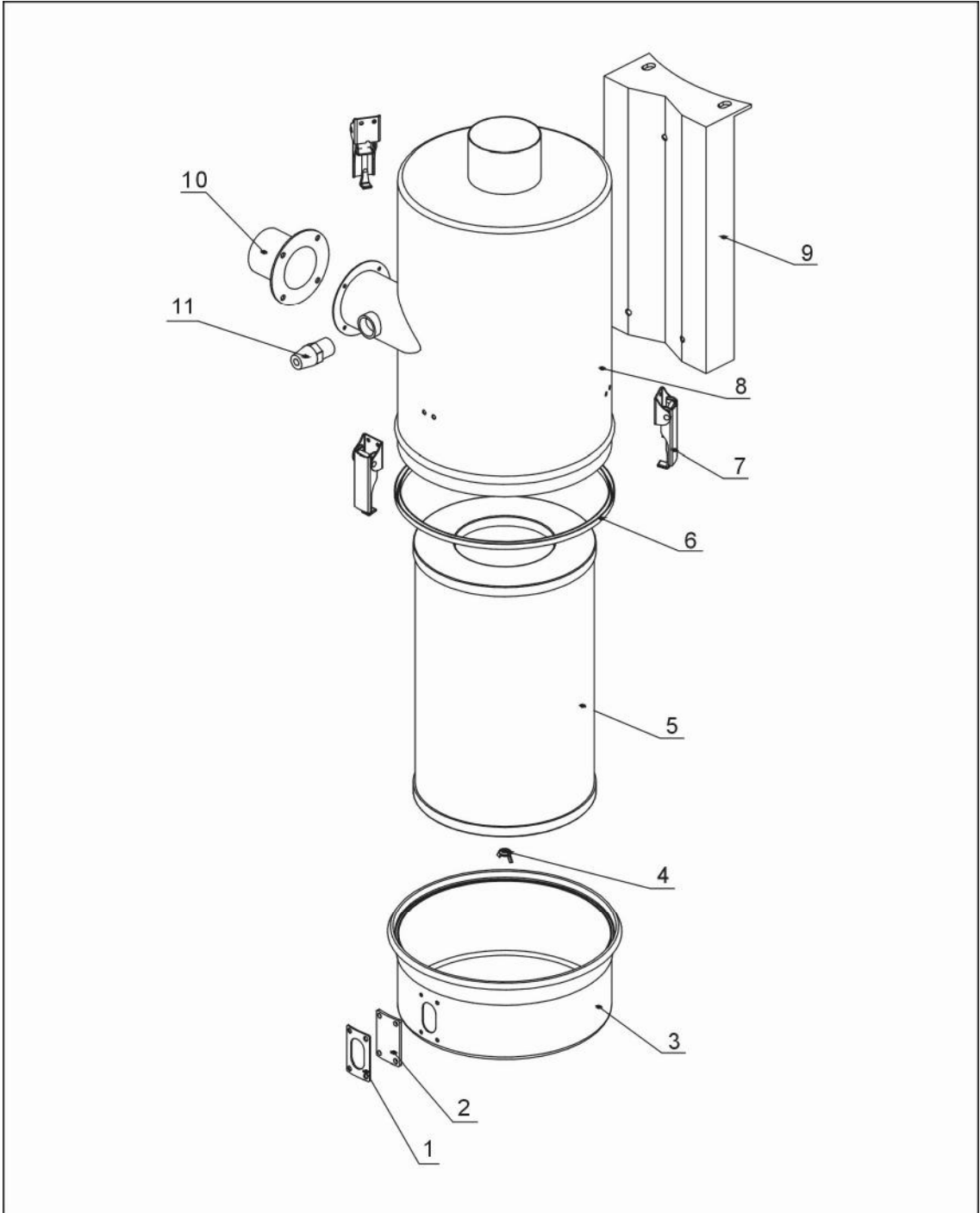

Remarks: Please refer to Material List 2.2.7 for specific explanation of the Arabic numbers in Parts Drawing.

Picture 2-6: Parts Drawing of Hot-air Recycler

2.2.7 Parts & Materials List of Hot-air Recycler (SHD-40U~120U-HD)

Chart 2-3: Parts & Materials List of Hot-air Recycler (SHD-40U~120U-HD)

No.	Name	Part No.		
		SHD-40U-HD	SHD-80U-HD	SHD-120U-HD
1	Sight-glass	-	-	-
2	Acryl	-	-	-
3	Dust collection bin	-	-	-
4	Butterfly Nut	YW69051600000	YW69051600000	YW69051600000
5	Filter	YR50138000000	YR50181100000	YR50181100000
6	Fastener for filtering barrel	YR10016000000	YR10708000100	YR10708000100
7	Snap hook	YW02003000400	YW02003000400	YW02003000400
8	Filter barrel	-	-	-
9	Filter's Setting Plate	-	-	-
10	Nozzle Flange	-	-	-
11	Exhaust-air Filter	-	-	-

* means possible broken parts.

** means easy broken part. and spare backup is suggested.

Please confirm the version of manual before placing the purchase order to guarantee that the item number of the spare part is in accordance with the real object.

2.3 Electrical Diagram

2.3.1 Electrical Diagram (SHD-40U~120U-HD)

Chart 2-4: Electrical Diagram (SHD-40U~120U-HD)

Symbol Type	(a)	(b)	(c)	(d)	(e)	(f)	(g)	(h)	(i)	(j)	(k)
SHD-20U-HD	3.75	2.5	16	10	0.3	1	0.05	0.25	1.5	2.2	3.3
SHD-40U-HD	4.9	2.5	16	10	0.44	1	0.12	0.4	1.5	3.0	4.5
SHD-80U-HD	6.3	2.5	16	10	0.44	1	0.12	0.4	1.5	3.9	5.9
SHD-120U-HD	6.3	2.5	16	10	0.44	1	0.12	0.4	1.5	3.9	5.9

(a) Total current

(c) Main power switch

(e) Thermo relay setting of drying blower

(g) Power of drying blower

(i) Power cable dia. of heater

(k) Current of drying heater

(b) Main power cable dia.

(d) Circuit breaker of drying heater

(f) Power cable dia. of drying blower

(h) Drying blower power of drying blower

(j) Power of drying heater

2.3.2 Main Circuit (SHD-40U~120U-HD)

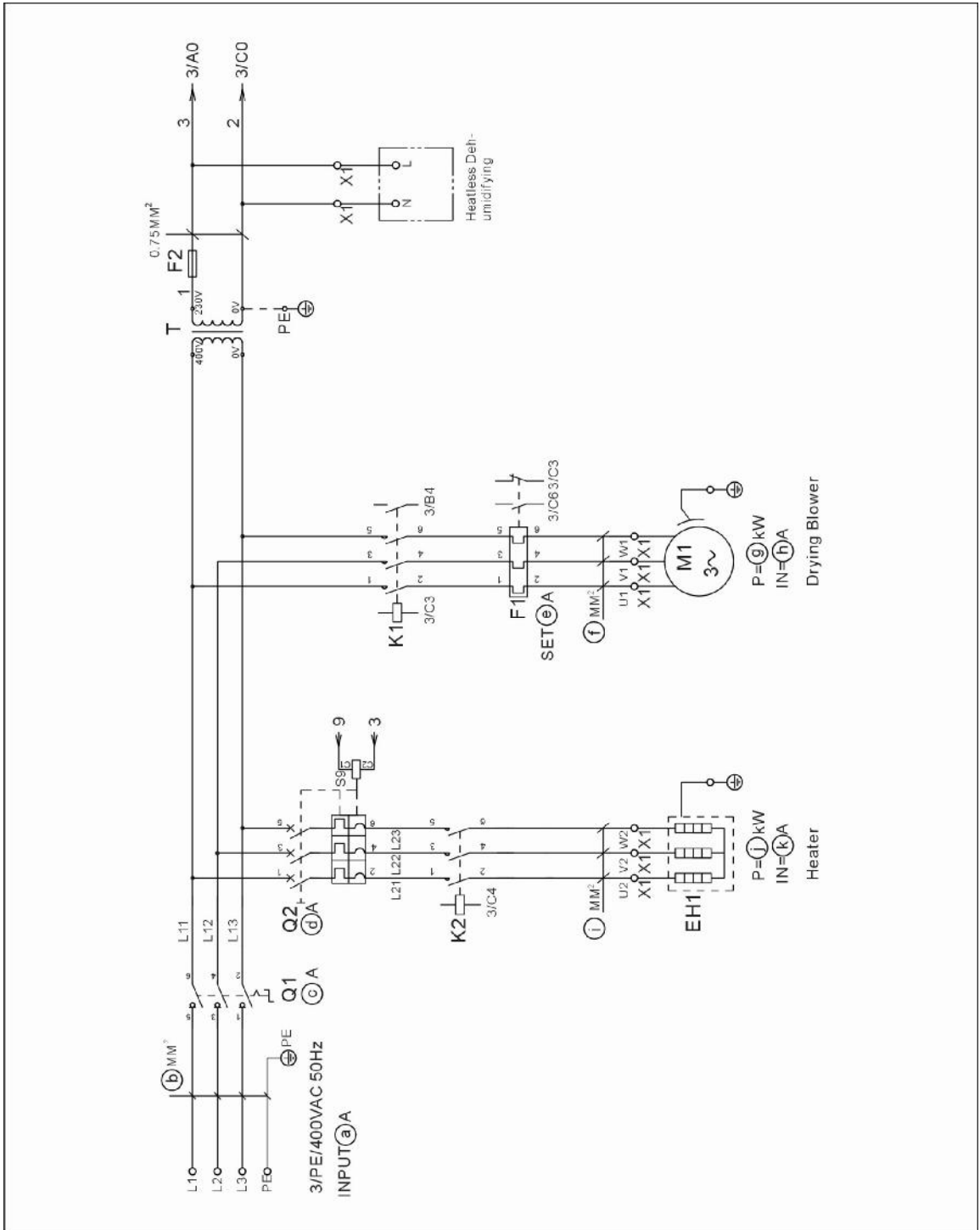

Picture 2-5: Main Circuit (SHD-40U~120U-HD)

2.3.3 Control Circuit (SHD-40U~120U-HD)

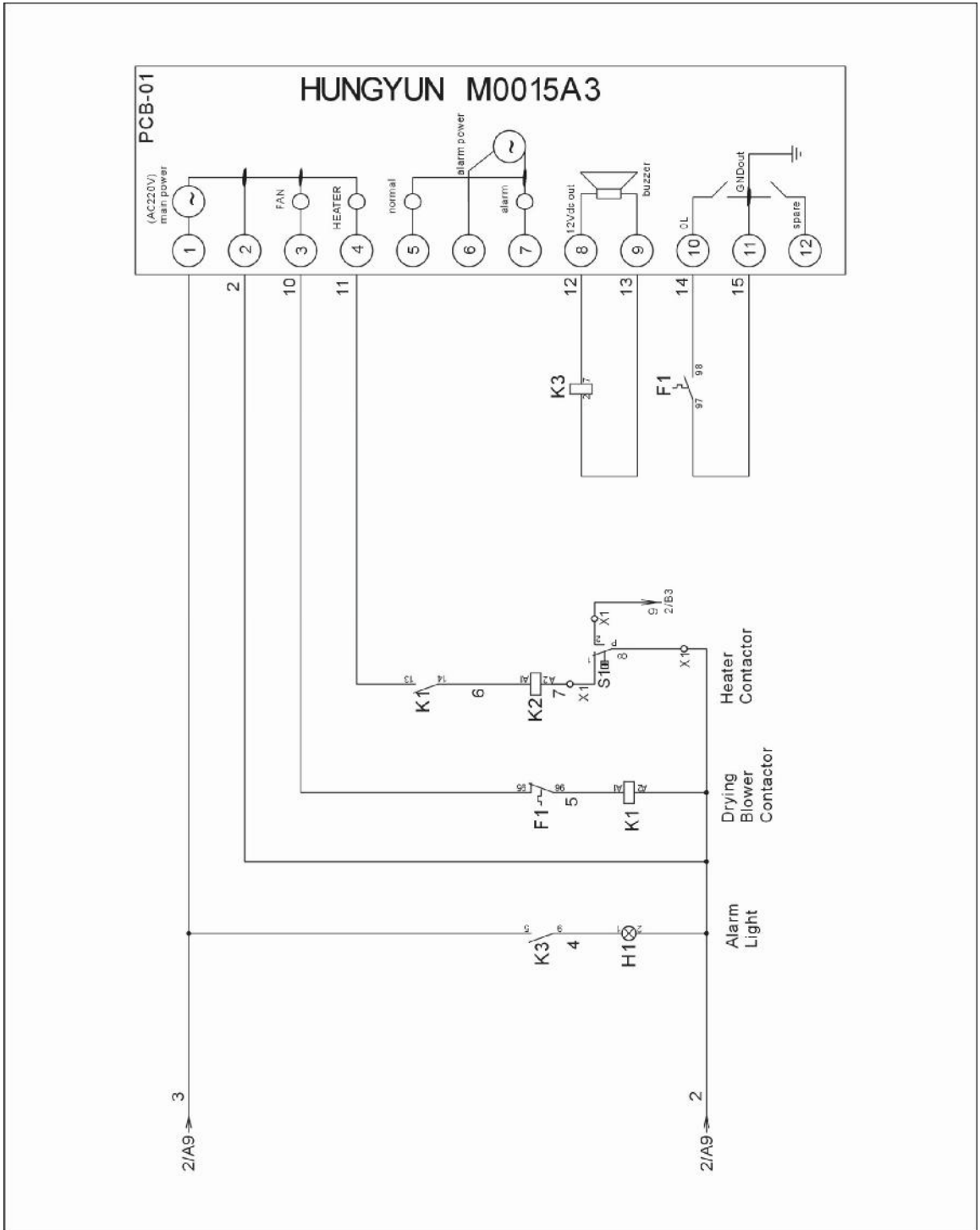

Picture 2-6: Control Circuit (SHD-40U~120U-HD)

2.3.4 Thermocouple and Terminal Layout (SHD-40U~120U-HD)

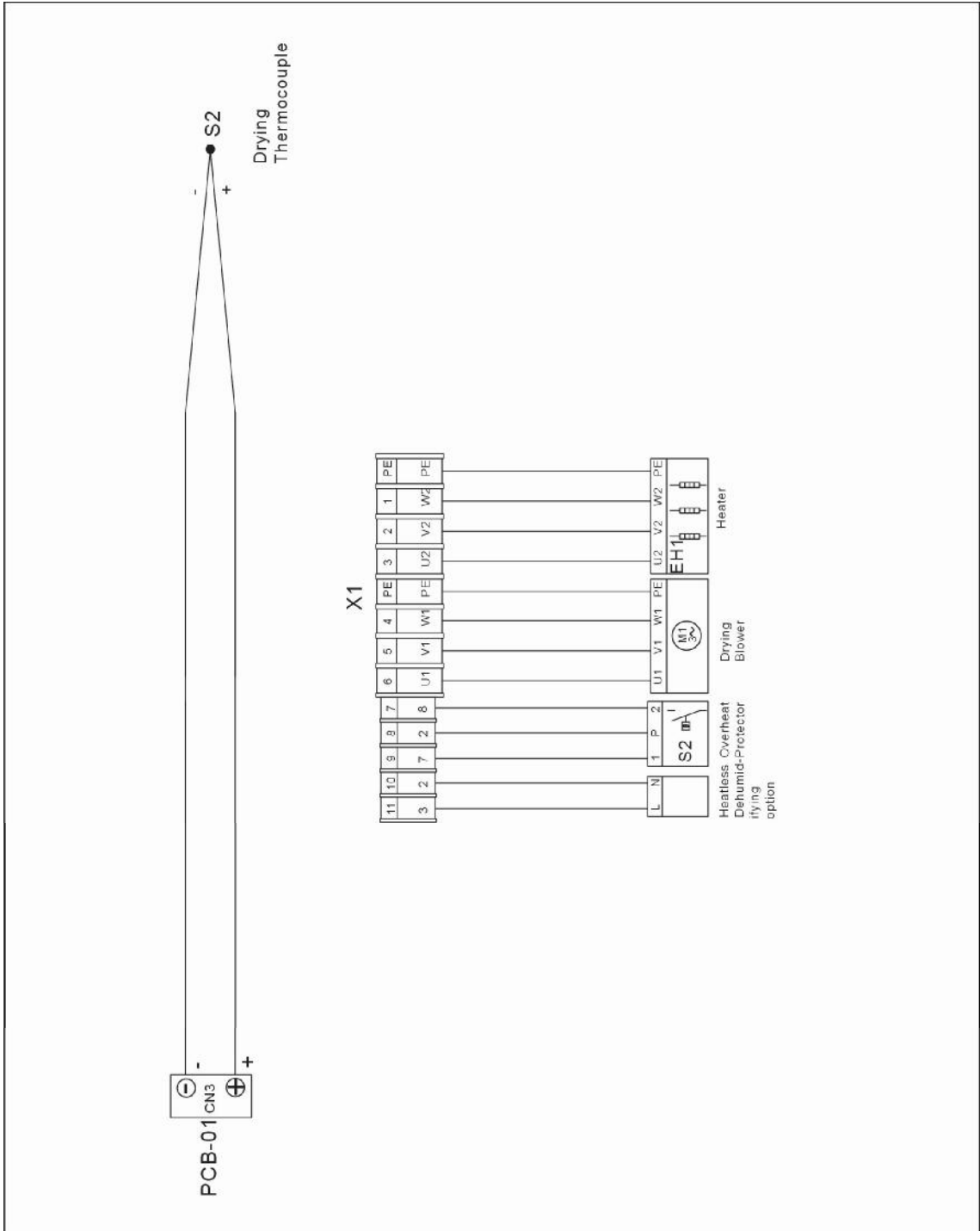

Picture 2-7: Thermocouple and Terminal Layout (SHD-40U~120U-HD)

2.3.5 Components Layout (SHD-40U~120U-HD)

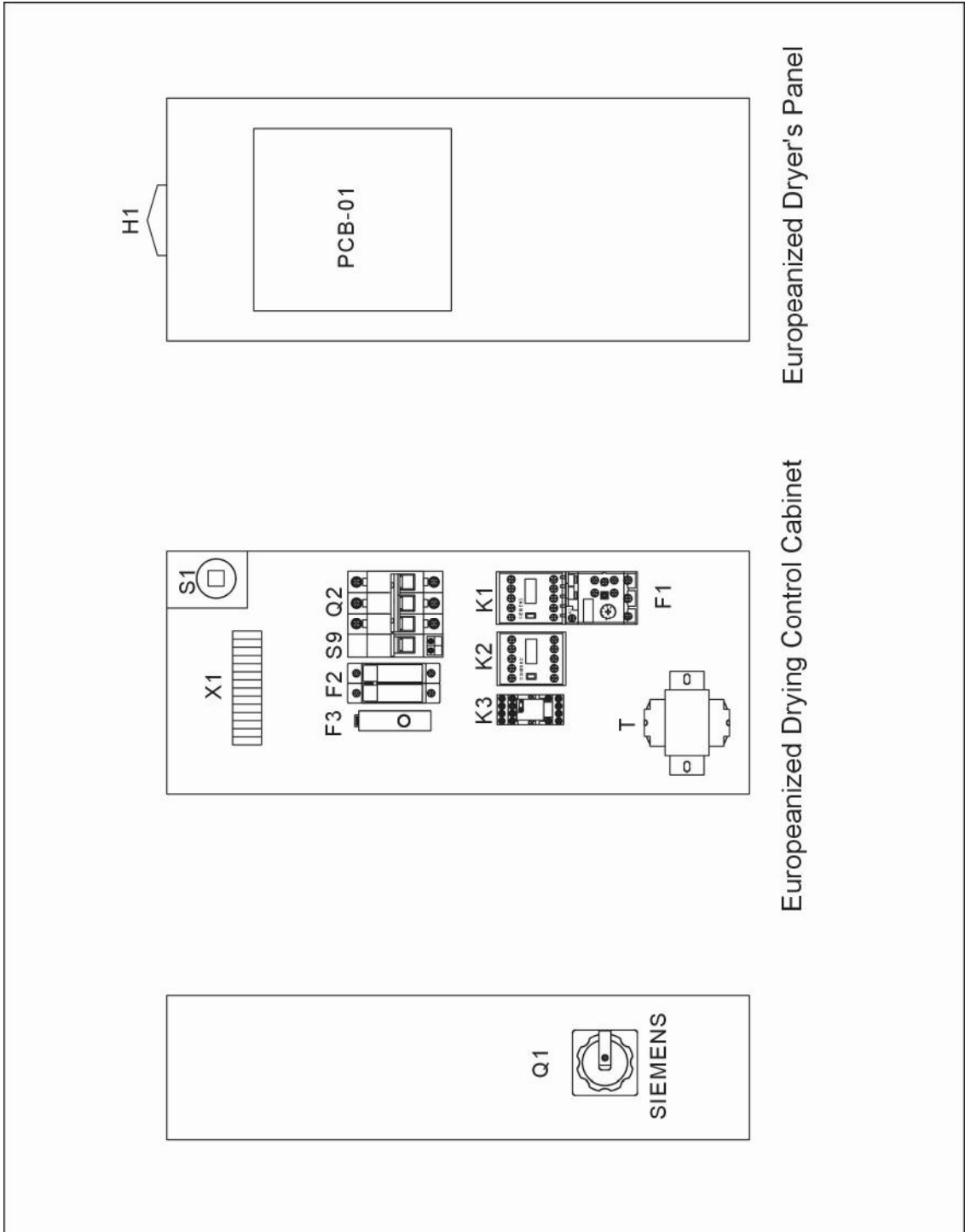

Picture 2-8: Components Layout (SHD-40U~120U-HD)

2.3.6 Electrical Components List (SHD-40U~120U-HD)

Chart 2-5: Electrical Components List (SHD-40U-HD)

NO.	Symbol	Name	SHD-40U-HD	
			Specification	Part NO.
1	Q1	Main switch	16A 3P	YE10200300000
2	Q2	Circuit-breaker*	10A 400V 3P	YE40631000000
3	-	Excitation break away	-	YE40000900000
4	K1	Contacto ^r *	9A 3P 1NO 230V 50/60Hz	YE00301000000
5	K2	Contacto ^r *	9A 3P 1NO 230V 50/60Hz	YE00300000000
6	K3	Middle relay*	5A 2P 12VDC	YE03271200000
7	T	Transformer*	IN=400V OUT=230V 500mA	YE70402300800
8	F1	Overload relay*	0.4~0.63A 690V 50/60Hz	YE01046300000
9	F2	Fuse**	6×30mm 2A 250VAC	YE41001000000
10	PCB-01	PCB*	STC43/44 230VAC	YE80001500000
11	S1	Overheat protector	250V 16A	YE85540000000
12	S2	Thermocouple*	-	BE90052000050
13	H1	Alarm lamp	230V 50/60Hz	YE83305100200
14	X1	Terminal	2.5mm ²	YE61250000000
15	-	-	2.5mm ² PE	YE61253500000
16	M1	Blower*	3Φ 400V 50Hz 50W 2P	BM40025300450
17	EH1	Heater*	3Φ 400V 50Hz 2.2kW	BH70400300350

* means possible broken parts.

** means easy broken part. and spare backup is suggested.

Please confirm the version of manual before placing the purchase order to guarantee that the item number of the spare part is in accordance with the real object.

Chart 2-6: Electrical Components List (SHD-80U/120U-HD)

NO.	Symbol	Name	SHD-80U/120U-HD	
			Specification	Part NO.
1	Q1	Main switch	16A 3P	YE10200300000
2	Q2	Circuit-breaker*	10A 400V 3P	YE40631000000
3	-	Excitation break away	-	YE40000900000
4	K1	Contacto ^r *	9A 3P 1NO 230V 50/60Hz	YE00301000000
5	K2	Contacto ^r *	9A 3P 1NO 230V 50/60Hz	YE00300000000
6	K3	Middle relay*	5A 2P 12VDC	YE03271200000
7	T	Transformer*	IN=400V OUT=230V 500mA	YE70402300800
8	F1	Overload relay*	0.4~0.63A 690V 50/60Hz	YE01046300000
9	F2	Fuse**	6×30mm 2A 250VAC	YE41001000000
10	PCB-01	PCB*	STC43/44 230VAC	YE80001500000
11	S1	Overheat protector	250V 16A	YE85540000000
12	S2	Thermocouple*	-	BE90052000050
13	H1	Alarm lamp	230V 50/60Hz	YE83305100200
14	X1	Terminal	2.5mm ²	YE61250000000
15	-	-	2.5mm ² PE	YE61253500000
16	M1	Blower*	3Φ 400V 50Hz 50W 2P	BM40338000050
17	EH1	Heater*	3Φ 400V 50Hz 2.2kW	BH70803900250

* means possible broken parts.

** means easy broken part. and spare backup is suggested.

Please confirm the version of manual before placing the purchase order to guarantee that the item number of the spare part is in accordance with the real object.

2.3.7 Main Electrical Components Description

Overload Relay

At delivery, the overload relay is set for manual reset. (the reset button pointing to H). Manually reset the relay at the tripping of the switch. When motor overload occurs, stop the machine, then check and solve the problem. After that open the door of control box, press down the reset button of overload relay (if you can not press down the reset button, wait for one minute.)

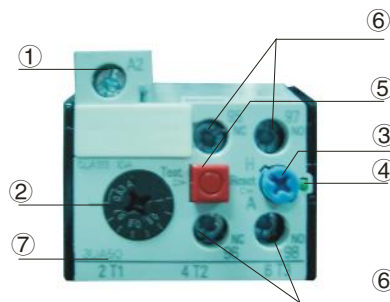

Picture 2-9: Overload Relay

1) Terminal for contact coil A2.

2) Setting current adjusting scale

3) Reset (blue)

H: manual reset

A: automatic reset

4) Switch position indication (green)

Tripping of a manual-resetting is indicated by a pin projecting from the front plate.

5) Test button(red)

6) Auxiliary contact terminals shown in 95.96.97.98. NC and NO contacts are shown in position 95.96. and 97.98. respectively.

7) Main circuit connection No. must be correspond with terminal Number of contactor.

2.4 Optional Accessories

2.4.1 Floor Stand

Each model can be supplied with suitable floor stand for easy moving.

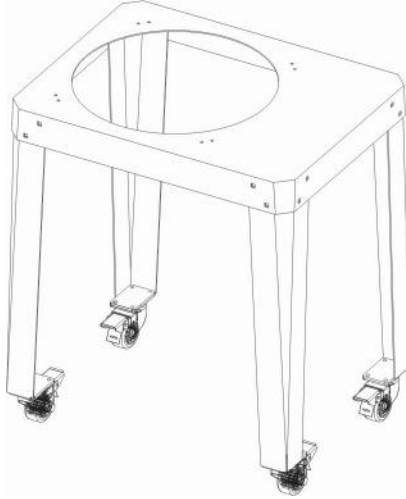

Floor Stand

Chart 2-7: Floor Stand Table

Floor stand	Suitable machine model	Specifications (mm)		
		Length (mm)	Width (mm)	Height (mm)
FSU-20	SHD-20U-HD	550	450	790
FSU-40	SHD-40U-HD			
FSU-80	SHD-80U-HD	722	552	840
	SHD-120U-HD			

2.4.2 Pneumatic Shut-off Valve and Suction Box

Euro-style in appearance design, work with dryer with floor stand and vacuum loader, suitable for material suction and discharging.



Picture 2-10: Pneumatic Shut-off Valve and Suction Box

Chart 2-8: Europeanized Suction Box's Selective Pairing List

SBU \ Model	SHD-U-HD
SBU	-20-38S
SBU	-20-50S
SBU	-20-38D
SBU	-20-50D

- Note: 1) Install pneumatic shut off valve (plus "V" at the back of model).
 2) Change into stainless steel (plus "S" at the back of model).
 3) Stainless steel polishing (plus "P" at the back of model).
 4) Single tube suction box (make "S" at the back of model),
 double tube (make "D" at the back of model).

3. Installation and Debugging

3.1 Attentions during Installation:

- 1) Make sure voltage and frequency of the power source comply with those indicated on the manufacture's plate, which is attached to the machine.
- 2) Power cable and earth connections should conform to local regulations.
- 3) Use independent power cable and ON / OFF switch. The cable's size should not smaller than those applied in the control box.
- 4) The power cable connection terminals should be tightened securely.
- 5) The machine requires a 3-phase 4-wire power source, connect the power lead (L1, L2, L3) to the live wires, and the earth (PE) to the ground.
- 6) Power supply requirements:
Main power voltage: $\pm 5\%$
Main power frequency: $\pm 2\%$
- 7) Make sure the piping system of the machine is well connected before you turn on the blower.

3.2 Installation Reference

3.2.1 Install directly on a moulding machine

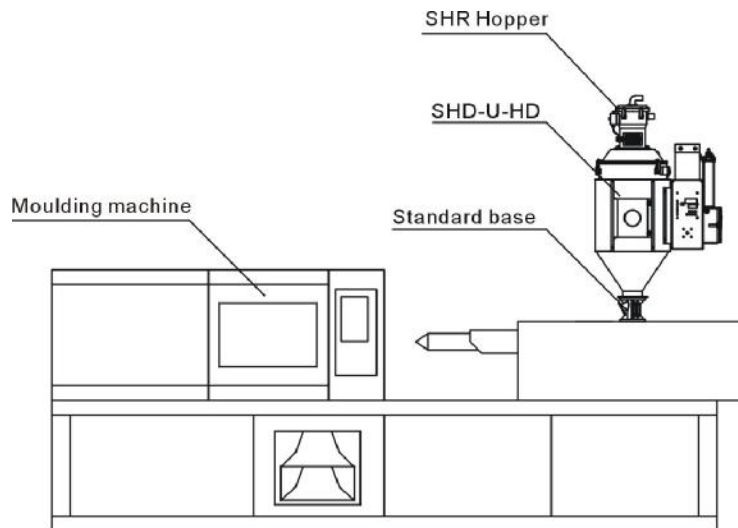

Picture 3-1: Installation Scheme of Injection Molding Machine

3.2.2 To be Used with Hopper Loaders

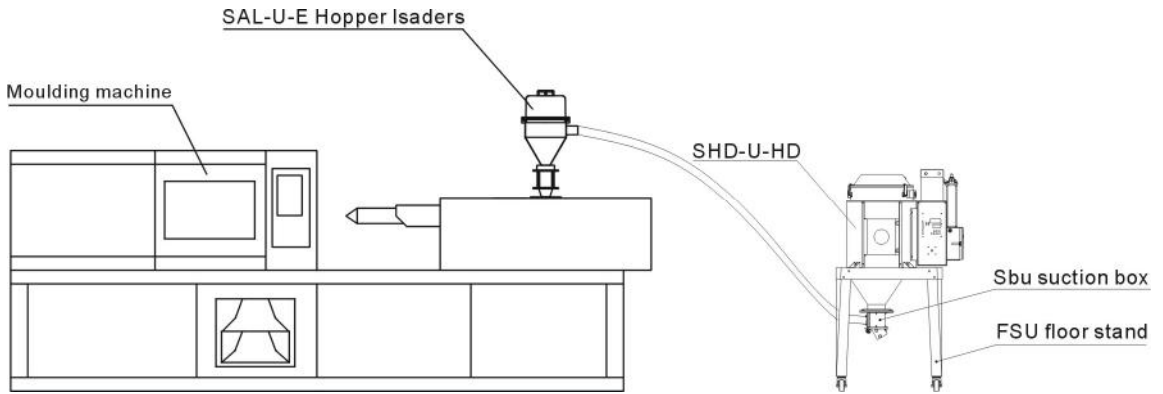

Picture 3-2: Installation Scheme of Receiver Hopper

3.3 Power Supply

Make sure that the power supply conforms to required specifications before installation.

SHD-U-HD per Dryers is generally set to be used with 3 Φ 400V 50Hz power supply or other specifications if required.

4. Application and Operation

4.1 Description of Control Panel

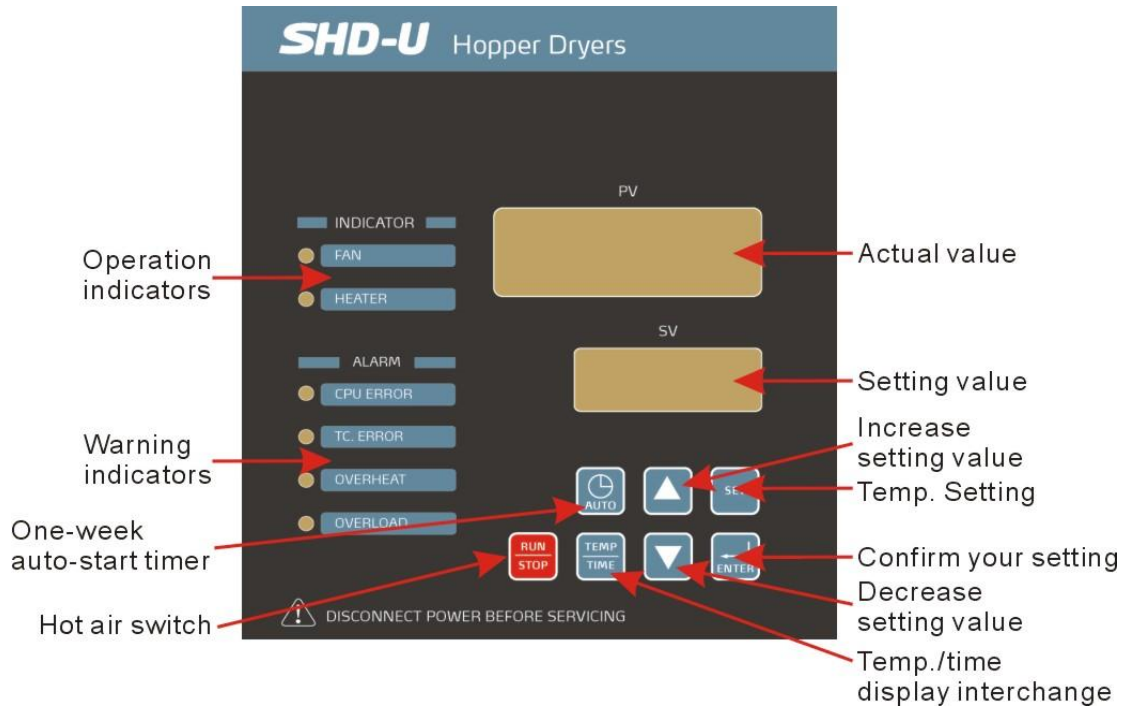

4.2 Operation of the Machine

- 1) Turn on the main power.
- 2) Press "RUN / STOP" button, the machine starts drying the materials.

4.3 Temperature Setting

- 1) Press "SET", temp. setting value flashes on the screen. Press ▲ ▼ to increase or decrease temp. setting value.
- 2) Press "ENTER" to confirm your setting.

4.4 Intermittent Drying Setting

Drying period (0-ON) \rightleftharpoons Off period (0-OFF)

- 1) Press "SET" key to change temp.setup value into time setup value, press "TEMP / TIMER" key to enter into setup mode, at this time "SV / setup value" flickers, "PV / setup value" displays "0-ON".



Picture 4-1: Intermittent Drying Setting-Chart 1

- 2) PV displays "0-ON" to stand for drying periods."0-OFF" stands for machine stop time. Press ▲▼ key to add or decrease time value of "SV / setup value". Each press of ▲▼ can add or decrease 15 mins set time.
- 3) Press "ENTER" to confirm the input time value and enter into "0-OFF" time setup items, then repeat step 2.





Picture 4-2: Intermittent Drying Setting-Chart 2

- Note: If set 0-ON as 04: 00, 0-OFF as 05: 00, which means drying periods is 4 hours stop time is 5 hours, then working for 4 hours and being stopped for 5 hours and repeat this so long.
- 4) Cancel intermittent running by entering 00.00 at "0-ON" or "0-OFF" press "ENTER" to confirm input value after time setup and enter into time setup items from "1-ON" "week-ON" .





Picture 4-3: Intermittent Drying Setting-Chart 3

4.5 Weekly Time Start Setup

- 1) Press   key to add or decrease the time value in "SV / setup value" from "1-ON". Press "ENTER" to confirm the input value and comes into the time setup items of "1-OFF""MON-OFF".



Picture 4-4: One-week Automatic Start / Stop Timer-Chart 1

- 2) Press   key to add or decrease the time value in "SV / setup value " from "1-OFF" . Press "ENTER" to confirm the input value and comes into the time setup items of "2-ON""TUE — ON".



Picture 4-5: One-week Automatic Start / Stop Timer-Chart 2

- 3) Do the same setup again and again to setup the ON / OFF time from Monday to Sunday.



Picture 4-6: One-week Automatic Start / Stop Timer-Chart 3

- 4) Press "SET" key to back to normal status, after finish all the setup.
- 5) Setup all the "ON" to 00: 00 if it is not for time start / stop.

Note:

1. F-20 functions as an password lock, hold on "SET" till the "PV" displays F-20.
2. Press ▲▼ key and only after input 0021 in the SV, can you press "ENTER" to come into F-04 and other settings, so F-20 functions as an passwordlock for entering into next parameters setup, which prevents the modification from unprofessionals.



Picture 4-7: One-week Automatic Start / Stop Timer-Chart 4

3. F-04 is data lockup function, press ▲▼ key to shift between OFF / LOCK, LOCK is for locking up information, not able to input or change any data; OFF is for lockup cancellation.



Picture 4-8: One-week Automatic Start / Stop Timer-Chart 5

4. Press "ENTER" key to confirm the input value and comes into next function item "F-05".
5. Because the first function key has two items, so jump into "F-04" after input "F-05", for exiting the function setting, press "SET" key.

4.6 System Clock Adjustment

- 1) Repeat the above steps until "PV" shows "TIME".
- 2) Press ▲▼ to increase or decrease setting value of the time.
- 3) Press "ENTER" "PV" shows the days of a week.
- 4) Press ▲▼ to increase or decrease the date.

Remarks: it shall re-check current time when the machine is idling for continuous ten days without power-on operation.

4.7 Enable One-week Automatic Start / Stop Timer

- 1) After you completed steps 6.5 and 6.6, it's ready to start automatic start / stop timer.
- 2) Press "AUTO" to enable this function. "PV" shows time and temperature alternatively.
- 3) Press "AUTO" once more to cancel this function.

4.8 Lock up the Machine

- 1) Press "ET" until "PV" displays F-20.
- 2) Press ▲▼ until "SV" changes to 0021, then press "ENTER", now "PV"

shows F-04

3) F-04 is used to define LOCK function. Press   to choose LOCK or OFF.

4) Press “ENTER” to confirm your setting.

5) If you choose LOCK in step 3, when you press “SET” "SV" displays "LOCK".

4.9 Meaning of Error Code

Chart 4-1: Meaning of Error Code

Error code	Meaning
E-01	Thermosensor break
E-02	Phase reversal
E-03	Overload
E-05	EGO cuts off the heater power when it is overheating
	Overheat
E-08	PCB problems

5. Trouble shooting

Troubles	Possible reasons	Solutions
The rotating direction of blower fan is not as indicated.	1. Blower phase-reversal	1. Exchange two of the electrical wires
Blower can not be started.	1. Motor failures	1. Repair or replace
	2. Failures of solenoid switch	2. Repair or replace
The blower and heater can not work.	1. Tripping of overload relay	1. Repair or replace
	2. Problems of transformer	2. Repair or replace
	3. Fuse melted	3. Repair or replace
	4. Troubles of power supply	4. Reconnect the power supply
The blower can work, but heater can not.	1. Poor connection of pipe heater	1. Repair or replace
	2. Problems of solenoid switch	2. Repair or replace
	3. Pipe heater problems	3. Repair or replace
	4. Temp. controller problems	4. Repair or replace
	5. Thermocouple problems	5. Replace thermocouple
The blower is working, but air temp. can not rise up.	1. Poor connection of pipe heater	1. Repair or replace
	2. Short circuit of overheat protector or tripping off	2. Repair or reset
	3. Phase shortage of solenoid switch	3. Repair or replace
	4. Temp. controller damaged.	4. Replace temp. controller
The blower can work, but the temp. is too high.	1. Hot air pipe jammed	1. Cleaning
	2. Errors or problems of the temp. controller	2. Replace temp. controller or adjust the knob
	3. The electrical contactor broken	3. Repair or replace



Note!

Main switch must be turned "OFF" when checking or replacing the components of the machine.

6. Maintenance and Repair

Blower cleaning

Remove the dust from both the inside and outside blower

Period: monthly

Check the working condition of the blower

Period: monthly

Check whether the heat resisting air pipe is damaged and the air inlet and outlet is sealing well

Period: Weekly

Check whether there is water in the filter cup, if yes, manually drain the cup.

Period: Daily

Heatless dehumidifying and regenerating dryer.

Installation: install the dryer with 4 × M6 inside hexagon cap head screw.

Replace the adsorbent.

Maintenance and Repair: see the instruction manual of HAD

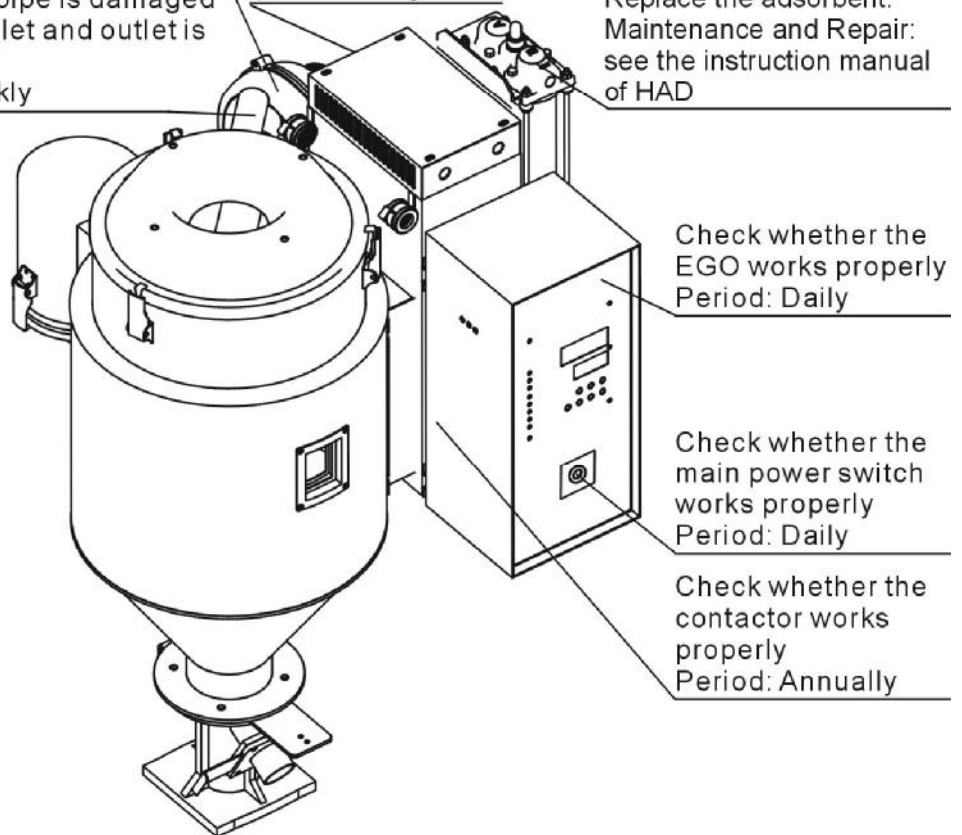

Check whether the EGO works properly
Period: Daily

Check whether the main power switch works properly
Period: Daily

Check whether the contactor works properly
Period: Annually

6.1 Hot-air Recycler

Please check the hot-air recycler and clean the filter at fixed intervals and it is suggested to conduct the cleaning work each week and user might increase cleaning frequency if there is too much mill dust in plastic raw materials. The following is the cleaning method:

- 1) Unscrew the spring buckle (7), dump off the mill dust in dust collection barrel (3).
- 2) Unscrew butterfly nut (4), take off filter (5) and blow the filter from inside

outwards with high-pressure air until it is clean.

- 3) Accomplish the assembly of hot-air recycler in opposite order after the cleaning work is over.

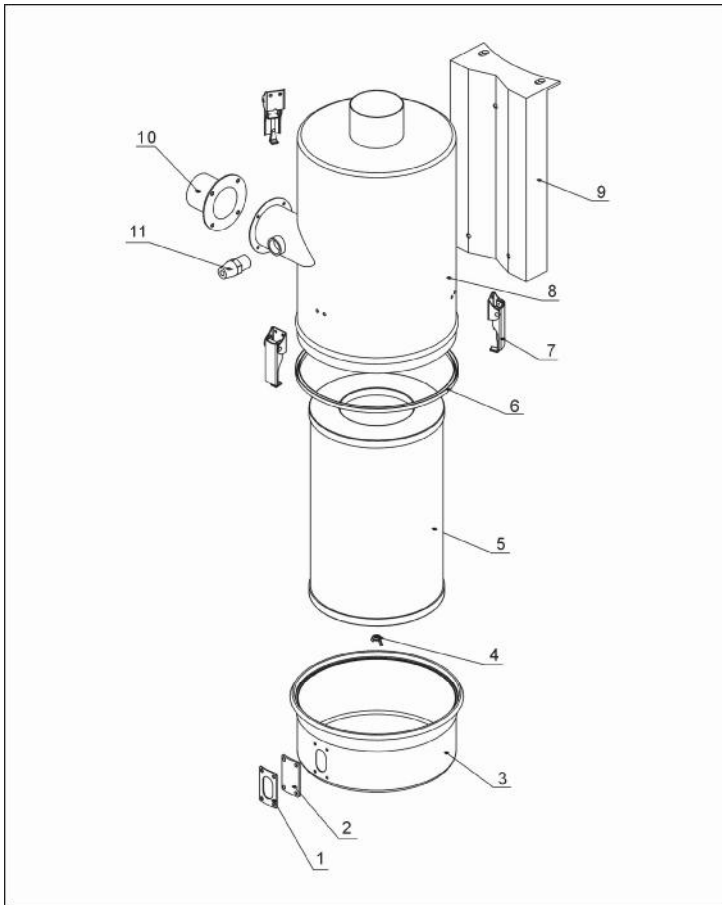

Picture 6-8: Parts Drawing of Hot-air Recycler

6.1.1 Exhaust-air Filter

Please clean the exhaust filter (as the picture 11 above) at fixed intervals and use high-pressure air to clean it from inside outwards. Screw tight the machine after the cleaning and drying are finished. It is suggested to conduct the cleaning work each week and user might increase cleaning frequency if there is too much mill dust in plastic raw materials.

6.2 GXW/GW Athermal Regeneration Type of Air Dryer

Thanks for using GXW type of air dryer. Please read carefully this instruction book before you start using it in order to give full play to this product's

performance with safe and maintenance-free operation! GXW small-sized dryer belongs to wall type of athermal, regeneration and adsorption air dryer, which utilizes pressure varying adsorption principle to dry and compress air. It introduces the packaged design and high liability of American technique to provide the advanced purifying equipment for enterprises in all industries.

6.2.1 Operation Instruction

GXW small-sized dryer realizes fully automatic operation with less maintenance. It contains two drying cylinders, two shuttle valves, two solenoid valves, one regeneration type of air control valve and the controller executes programming control. Water vapor is adsorbed when humid air enters one drying tower. At the same time, the other drying tower conducts regeneration before one pressurization process is completed and the same process is repeated at fixed interval to continuously provide purified, dry and compressed air with constant pressure.

6.2.2 Model and Specification

GXW* Model	-0.1/1	0.15/1	0.2/1	-0.3/1
Actual Handling Capacity (m ³ /min)	0.1	0.16	0.23	0.33
Caliber of Inlet & Outlet (Pipe Thread)	1/4"	1/4"	1/4"	1/4"
Length A(mm)	195	195	195	195
Width B(mm)	135	135	135	135
Height C(mm)	525	605	675	745
Mounting Hole Length D(mm)	178	178	178	178
Equipment Hole Height E(mm)	212	292	362	452
Equipment Weight (kg)	13	15	16	17

Remarks: * in GXW* models represents dew-point level. 1 stands for pressure dew-point at -70°C; 2 stands for pressure dew-point at -40°C; 3 stands for pressure dew-point at -20°C.

6.2.2.1 Operation Instruction

- 1) GXW small-sized dryer can work under pressure between 0.3 to 1.0MPa. But its dew-point guarantee value is under pressure of 0.7MPa with inlet temperature at 40°C.
- 2) Maximum inlet temperature is at 52°C but its dew-point will also rise; do not run the dryer under temperature that might freeze.

- 3) Please manually discharge water in front filter often or equip it with automatic water trap to avoid water's entering the drying tower and invalidate the dryer!
- 4) The filter cup's copper bottom valve of in front filters of LN12-0.5/1A and LN12-1/1A belongs to pressure-difference valve, which is turned off when there is pressure and is automatically turned on to discharge water when there is no pressure. Please push hard the copper bottom valve of the filter cup upwards to make it discharge water if there is water inside the filter cup when it is under continuous operation. The LN12-2/1 front filter has manual ball valve. Please discharge water at fixed intervals.
- 5) Customer may remove the muffler if the exhaust sound is to bring. Please use larger pipeline to connect with the outlet and make it extend outdoors.

6.2.2.2 Controller

- 1) Controller controls the ON/OFF of the solenoid valve with periods at 1, 2, 3 and 10. User shall select 1 or 2 minutes when dew-point is low, but the gas consumption is high at the same time. Therefore user might select five or ten minutes when the requirement is not high. It indicates one minute when the switch is on "02"; two minutes when the switch is on "ON"; five minutes when the switch is on "12"; ten minutes when the switch is on "1N".
- 2) Red light indicates power on; Flicker of left green light indicates power on in left solenoid valve; Flicker of right green light indicates power on in right solenoid valve.

6.2.3 Technical Parameter

Inlet Pressure	0.3~1.0MPa	Inlet Temperature	≤ 40℃
Dew-point Temperature	-40, -70℃	Pressure Loss	≤ 0.03MPa
Regeneration Type	Athermal Regeneration	Regeneration Air Consumption	5%~25% Rated Air Handling Capacity
Inlet Oil-bearing	≤ 0.1ppm	Adsorbent	Alumina, Molecular Sieve
Working Period	1、 2、 5、 10 Minute	Power Supply, Power Consumption	220V/50Hz, 12W

6.2.4 Maintenance

- 6.2.4.1 Filed adjustment and supervision: free from filed adjustment and any

lubrication

- 1) Pay attention to the solenoid valve in daily time. Take apart the solenoid valve body when exhaust is noisy or exhaust in left and right towers is different to check if there is any blockage caused by mill dust or to replace new solenoid valve.
- 2) Observer whether or not there is water in front filter. Please push hard the copper valve (or open the manual valve) at the filter cup's bottom to discharge water when there is water inside the filter cup.

6.2.4.2 Check after six months

- 1) It is suggested to conduct the check six months after the use of the machine. Listen to the power transformation and also the flow of regenerated air in drying tower cylinders. Check if there is too much dust and oil stain at air inlet and regeneration exhaust outlet to judge the abrasion condition of the adsorbent. Please remove the muffler, if there is any, to check if there is over-sized pressure fall. Replace new muffler if there is over-sized pressure fall.
- 2) Check the filter element of the filter. Please replace new one if it has worked for 3,000 to 4,000 hours.

6.2.4.3 Adjustment of regenerated air

If operation conditions change (such as inlet pressure, outlet flow capacity), it is necessary to adjust the regenerated air. Increase the amount of regenerated air if inlet pressure reduces, inlet temperature rises or humidity in summer is high; vice versa. User should notice that the size of regenerated air amount plays the key role in the operation of dryer. Undersized regenerated air amount might lead to the abnormal operation of the dryer.

6.2.4.4 Controller

Controller is free from maintenance and it can be replaced on site.

6.2.4.5 Drying Tower

It belongs to the welding structure and user must purchase a spare one if it is damaged.

6.2.4.6 Inappropriate Operation

E.g.: low inlet pressure, high air temperature or high outlet flow capacity, running dryer after the outlet valve has been off for several hours, over-wet regeneration drying cylinder, etc.

6.2.4.7 Oil Contamination

Oil contamination might lead to total failure of drying agent. User must replace adsorbent if there is any oil in drying tower or other spare parts, which makes the suitable maintenance of the front filter necessary.

6.2.4.8 Replacement of Absorbent

Generally speaking, the service life of adsorbent is over two years. It shall replace new one if outlet mill dust increases or dew-point remarkably descends. The following are steps for replacement:

- 1) Cut the power off and completely release the inner pressure of the dryer.
- 2) Screw off the muffler and solenoid valve.
- 3) Unscrew loose and take apart the copper pipe coupling near the regeneration air adjustment valve on top of drying tower, screw off the two oil screws both on top of and at the bottom of the drying tower.
- 4) Screw off the T-joint (four in total) on both ends of the drying tower.
- 5) Reach into the tower body from the upper end of the drying tower with the use of M6x100 bolt, make it connect with M6 nut on sieve plate, and hang tight the spring in the tower.
- 6) Screw off the diffuser at the bottom of the tower with the use of spanner, the adsorbent will flow out and empty the diffuser.
- 7) Assemble well the diffuser (as to the selection and application of adsorbent: use $\Phi 3\sim 5$ mm aluminum trioxide when dew-point requirement is at -40°C ; use $\Phi 3\sim 5$ mm13* molecular sieve when dew-point requirement is at -70°C) after refill new adsorbent.
- 8) Loosen the spring hanged tight by M6*100 bolt and confirm that the adsorbent has been well compressed.

- 9) Accomplish the assembly in opposite order.
- 10) Use soap water for air tightness test. No leakage indicates the acceptance.
Attentions: leakage might make pressure fall increase and dew-point rise.

6.2.4.9 Filter Element Replacement

1. Steps for the replacement of filter element in LN24-0.5/1A and LN24-1/1A filter:
 - 1) Totally release pressure inside the air filter.
 - 2) Take apart the automatic sewer valve (if there is any).
 - 3) Screw off filter cup's protection shield after pull down the locating block.
 - 4) Pull down the filter cup and take it off.
 - 5) Hold tight the filter element and screw off the hanger bolt. Hanger bolt and the filter element belong to one piece.
 - 6) Take out old filter element and handle it in accordance with related environment protection rules.
 - 7) Clean the inner wall of the filter cup with the use of only soap water and clean water.
 - 8) Screw tight the bolt and assemble well the new filter element.
 - 9) Check if the "O" type ring on both ends of the filter cup is in good position and insert the filter cup in the filter cup.
 - 10) Rotate it after cover it with filter cup's protection shield to make the locating block fall in the slot for locating.
2. LN24-2/1 Steps for the replacement of filter element of the filter:
 - 1) Totally release pressure inside the air filter.
 - 2) Take apart the automatic sewer valve (if there is any).
 - 3) Screw off the filter cylinder. It might use pulley wrench or spanner in order to screw off the filter cylinder.
 - 4) Loosen and take apart the hanger bolt. Hanger bolt is used for locating the filter element.
 - 5) Take out old filter element and handle it in accordance with related environment protection rules.
 - 6) Clean the inner wall of the filter cup with the use of only soap water and clean water.

- 7) Screw tight the bolt and assemble well the new filter element.
- 8) Check if the “O” type ring on both ends of the filter cup is in good position, screw tight the filter cylinder and accomplish the connection with sewer valve.

6.2.4.10 Trouble-shooting Instructions for Regeneration Type of Air Dryer

Symptom	Possible Reasons	Suggestion
A. Over-high Pressure	<ol style="list-style-type: none"> 1. Dirty or blocked front filter 2. Dirty or blocked back filter 3. Dirty or blocked diffuser 4. Over-high inlet flow capacity or gas consumption 5. Over-low inlet pressure 6. Severe damage of adsorbent 	<ol style="list-style-type: none"> 1. Replace filter element of front filter 2. Replace filter element of back filter 3. Check and clean diffuser 4. Check inlet flow capacity or gas consumption in accordance with regulated amount 5. Increase inlet pressure and make it reach regulated working pressure 6. Select and replace adsorbent
B. Error in switching the two drying towers of the dryer (shuttle valve is not switched)	<ol style="list-style-type: none"> 1. Blockage of muffler 2. Error in timing controller 3. Jamming of solenoid valve (blockage by dust powder) 4. Undersized regenerated air flow capacity 5. Inlet pressure under 0.3Mpa 6. Falling off of the sealing ring in the shuttle valve 7. Contaminated shuttle valve 8. Wire break or burned solenoid loop 	<ol style="list-style-type: none"> 1. Replace muffler 2. Please replace 3. Dismantle and sweep the solenoid valve; if the error still exists, Please replace 4. Increase the amount of regenerated air 5. Increase inlet pressure 6. Re-arrange (dip in a little glue) or replace 7. Clean, repair, replace 8. Repair or replace loop
C. High dew-point	<ol style="list-style-type: none"> 1. Insufficient or over-high regenerated air flow capacity 2. Inlet pressure is lower than the regulation 3. Inlet flow capacity is larger than the regulation 4. Fluid water enters the dryer 5. Inlet temperature is higher than the regulation 6. Dust powder in adsorbent 7. Adsorbent is contaminated by oil 8. Muffler is blocked or there is over-high back pressure during the exhaust 9. Leakage in outlet pipeline 	<ol style="list-style-type: none"> 1. Increase or reduce regenerated air amount through adjustment valve 2. Increase inlet pressure in accordance with regulation 3. Reduce inlet flow capacity in accordance with regulation 4. Check if there is any leakage in freezing pipeline of back freezer and freezing-water system 5. Check if the filter element of the filter and the bottom sealing is loosened; check if the sewer valve can normally discharge water; 6. Check back freezer and freezing-water system and adjust the inlet temperature in accordance with regulation. 7. Execute check and modification in accordance with actual requirements; check if there is any surge in pressure and flow capacity of the compressed air. 8. Check the front filter and sewer valve,

		<p>clean, repair and replace muffler. If air exhaust still does not work after dismantling the muffler, please contact equipment maintenance and repair department of SHINI.</p> <p>9. Check air pipeline and execute air leakage test with the use of soap water.</p>
--	--	--

6.3 Blower

- 1) Clean inner and outer parts (especially at blower inlet) of the blower periodically.
- 2) Remove the dusts on leaves of the fan.

6.4 Maintenance Schedule

6.4.1 About the Machine

Model _____ SN _____ Manufacture date _____

Voltage _____ Φ _____ V Frequency _____ Hz Power _____ kW

6.4.2 Installation & Inspection

- Check if the pipe joint is tightly locked by clips or not.
- Check that the material clearance door is firmly closed.
- Check that the piping system is correctly connected.

Electrical Installation

- Voltage: _____ V _____ Hz
- Fuse melt current: 1 Phase _____ A 3 Phase _____ A
- Check phase sequence of the power supply.
- Check the rotating direction of the blower.

6.4.3 Daily Checking

- Check the switches of the machine.
- Check auto-start function of the machine.

6.4.4 Weekly Checking

- Check all the electrical cables of the machine.
- Check if there are loose electrical connections.

6.4.5 Monthly Checking

- Check that the pipe heater is working properly.
- Check the performance of blower.
- Check the functions of electrical components.

6.4.6 Half-yearly Checking

- Check if there are damages of heat-resistant hose or not.
- Check the process heater.
- Check the blower.