

CU-23

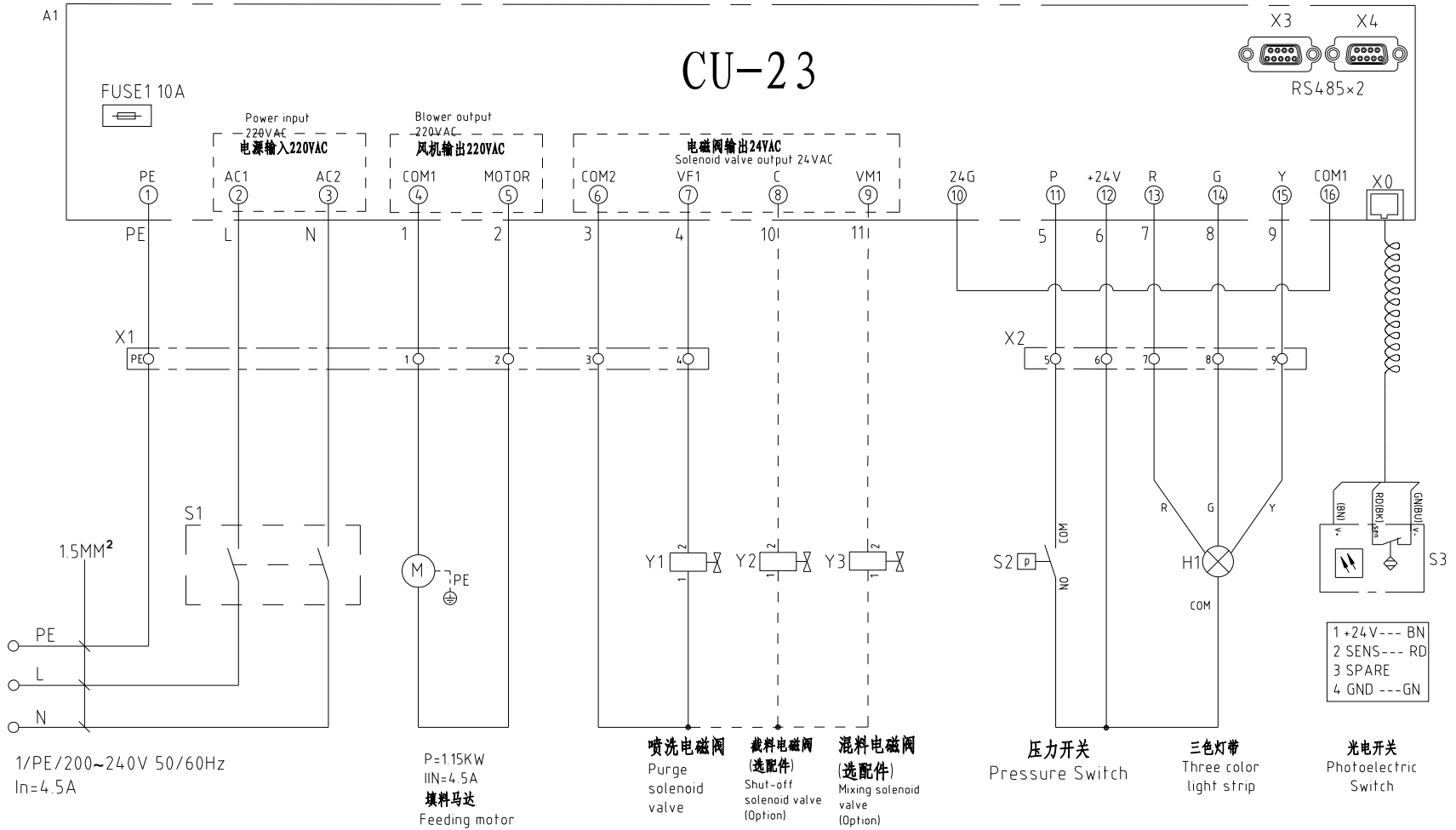

- 1 +24V --- BN
- 2 SENS --- RD
- 3 SPARE
- 4 GND --- GN

机型版本 Ver.C

接裁料阀与混料阀需要拆控制箱，从PG锁头穿过，直接接到线路板端子

The cut-off valve and mixing valve need to be disassembled from the control box, passed through the PG lock, and directly connected to the circuit board terminal

| | | | | | | | | | | | | | | | | | | | | | | | |
|----|--|--|--|--|--|-----|--|----------|--|--|--|-----------|--|--------|--|-----------------------|--|------|--|-------|--|-------|--|
| 制图 | | | | | | 版号 | | F | | 标题 | | SAL-12U-E | | 图号 | | SAL-12U-E-CE-230V-F-1 | | 比例 | | 第 1 张 | | | |
| 设计 | | | | | | 核准 | | | | 主电路图 | | | | | | | | 标准 | | CE | | 共 3 张 | |
| 校对 | | | | | | 日期 | | 20240529 | |  信易電熱機械股份有限公司 Shini Plastics Technologies, Inc. | | 机器电压 | | 1φ230V | | | | | | | | | |
| 标记 | | | | | | 更改前 | | 更改后 | | | | 更改人 | | 日期 | | 审核 | | 机器频率 | | 50HZ | | | |

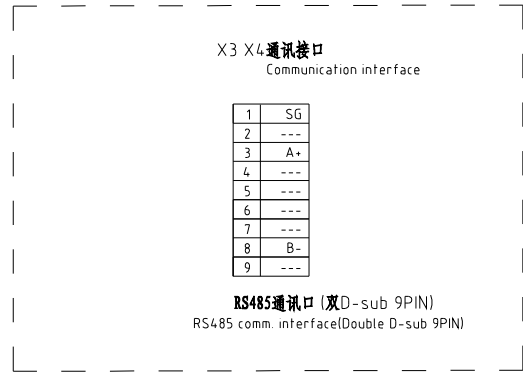
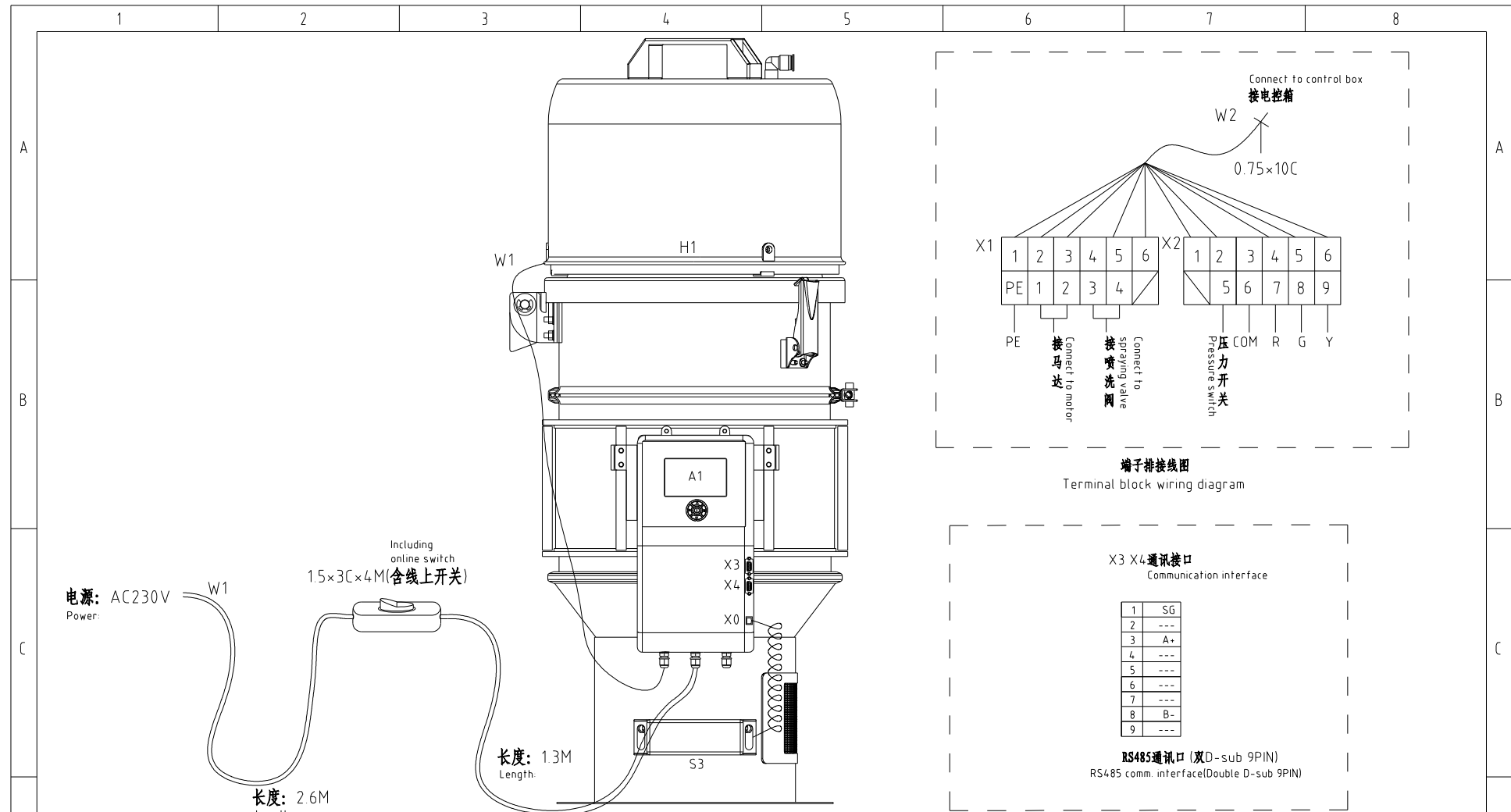

RS485 通讯接线图
RS485 Comm. wiring diagram

机型版本 Ver.C

| | | | | | | | | | | | | | |
|----|-----|-----|-----|----|----|----|----------|---|-----------|--------|-----------------------|-------|-------|
| | | | | | 制图 | 版号 | F | 标题 | SAL-12U-E | 图号 | SAL-12U-E-CE-230V-F-2 | 比例 | 第 2 张 |
| | | | | | 设计 | 核 | | 电气元件布置图 | | 标准 | CE | 共 3 张 | |
| | | | | | 校对 | 准 | | 信易電熱機械股份有限公司 Shini Plastics Technologies, Inc. | 机器电压 | 1φ230V | | | |
| 标记 | 更改前 | 更改后 | 更改人 | 日期 | 审核 | 日期 | 20240529 | | 机器频率 | 50HZ | | | |

| 1 | | 2 | | 3 | | 4 | | 5 | | 6 | | 7 | | 8 | |
|--|-----------|--|--|------------------|--|-------------|--|---|--|--------------------------|-----------|----------------------|--|-----------|--|
| 序号/NO | 符号/Symbol | 名称/Name | | 制造商/Manufacturer | | 型号/Type | | 规格/Specification | | 单位/unit | 数量/Number | 物料编号/Material number | | 备注/Remark | |
| 1 | A1 | 微电脑主板/Microcomputer Mainboard | | YUYUN | | CU-23 | | 230VAC 50/60HZ | | PCS | 1 | YE80002300300 | | | |
| 2 | X1 | 端子排/Terminal Board | | TIANDA | | PA9X | | 10A | | PCS | 2 | YE61001200000 | | (1) | |
| 3 | W2 | 電線0.75*10C*100m(9白1黃線) Wire 0.75 * 10C * 100m (9 white and 1 yellow green) | | YONGCHEN | | 0.75*10C | | M | | PCS | 0.5 | YE50751000000 | | | |
| 4 | W1 | 电源线+线上开关 Power cord+online switch | | SHINI | | --- | | 1.5*3C*4M(含线上开关) Including online switch | | PCS | 1 | BE51308400150 | | | |
| 5 | S2 | 压力开关/Pressure Switch | | SIGNAL | | IPOLE | | NO 250VAC | | PCS | 1 | YE15021500000 | | (1) | |
| 6 | S3 | 磁簧开关/Reed switch | | SONON | | T18-3MNB-PE | | 24VDC | | PCS | 1 | BE15143900300 | | (1) | |
| 7 | H1 | 三色灯带 Three color light strip | | JINRUNXING | | RGY | | 24VDC | | PCS | 1 | YE83121200100 | | (1) | |
| 8 | M | 马达/Motor | | AMETEK | | 119656-10 | | 1.15KW 230V 50/60HZ | | PCS | 1 | --- | | | |
| 9 | Y1 Y2 Y3 | 电磁阀/Solenoid Vavle | | KAIYUN | | 3/8" | | 24 VAC | | PCS | 3 | --- | | | |
| 10 | | 電纜索頭PG9 Cable lock head PG9 | | --- | | --- | | | | PCS | 1 | --- | | | |
| 11 | | 電纜索頭PG13.5 Cable lock head PG13.5 | | --- | | --- | | | | PCS | 2 | --- | | | |
| 12 | | 管形端子E1008 Tubular terminal | | | | | | | | PCS | 20 | YE60100800200 | | | |
| <p>Note: (1) Means not part of control box 注：(1) 表示非电控箱安装。</p> | | | | | | | | | | | | | | | |
| 机型版本 Ver.C | | | | | | | | | | | | | | | |
| | | | | 制图 | | 版号 F | | 标题 SAL-12U-E | | 图号 SAL-12U-E-CE-230V-F-3 | | 比例 | | 第 3 张 | |
| | | | | 设计 | | 核 准 | | 电气元件明细表 | | | | 标准 CE | | 共 3 张 | |
| | | | | 校对 | | | |  信易電熱機械股份有限公司 Shini Plastics Technologies, Inc. | | | | 机器电压 | | 1φ230V | |
| 标记 | | 更改前 | | 更改后 | | 更改人 | | | | 日期 | | 20240529 | | 机器频率 | |
| 1 | | 2 | | 3 | | 4 | | 5 | | 6 | | 7 | | 8 | |