

SAL-430/460

Self-contained Hopper Loader

Date: Aug. 2019

Version: Ver.A



Content

1. General Description	5
1.1 Coding Principle.....	5
1.2 Main Features	5
1.3 Accessory option.....	5
1.4 Technical Specifications	7
1.4.1 Outer Dimensions.....	7
1.4.2 Loading Capacity.....	8
1.5 Safety Regulations.....	9
1.6 Exemption Clause.....	10
2. Structure Characteristics and Working Principle.....	12
3. Assembly Drawing	13
3.1 Assembly Drawing (SAL-430).....	13
3.2 Parts List (SAL-430).....	14
3.3 Assembly Drawing (SAL-460).....	15
3.4 Parts List (SAL-460).....	16
4. Electrical Circuit Diagram.....	17
4.1 Main Electrical Components Description.....	29
4.1.1 Microswitch.....	29
5. Installation and Debugging	30
5.1 Installation of SAL-430 / 460	30
5.2 Installation Space	31
6. Application and Operation.....	32
6.1 Start / Stop of the Machine	32
6.2 Control Panel	33
6.3 Function Setup	34
6.3.1 Setup.....	34
6.3.2 Actions	35
6.3.3 Parameter List	38
6.3.4 Other Settings	38
7. Trouble-shooting.....	39

7.1	Trouble Shooting for SAL-430/460 Series	39
8.	Maintenance and Repair	40
8.1	Filter Bag	40
8.2	Storage Hopper.....	41
8.3	Service Life of Product Key Part	41
8.4	Maintenance Schedule	42
8.4.1	About the Machine	42
8.4.2	Check after Installation.....	42
8.4.3	Daily Checking	42
8.4.4	Weekly Checking.....	42
8.4.5	Monthly Check.....	42

Table Index

Table 1-1:	Specifications	7
Table 3-1:	Parts List.....	14
Table 3-2:	Parts List.....	16
Table 6-1:	Control Panel Description.....	32

Picture Index

Picture 1-1:	Outer Dimensions	7
Picture 1-2:	Loading Capacity	8
Picture 2-1:	Working Principle	12
Picture 3-1:	Assembly Drawing (SAL-430)	13
Picture 3-2:	Assembly Drawing (SAL-460)	15
Picture 4-1:	Photoelectrical Sensor	29
Picture 5-1:	Installation Methods (SAL-430/460)	30
Picture 5-2:	Installation Space	31
Picture 6-1:	Control Panel	32
Picture 8-1:	Filter Screen.....	40

1. General Description



Please read through this operation manual before using and installation to avoid damage of the machine and personal injuries.

The SAL-430 / 460 series use a high voltage inductive motor with low noise level and long life. It also has an automatic reversal dust cleaning device.

1.1 Coding Principle

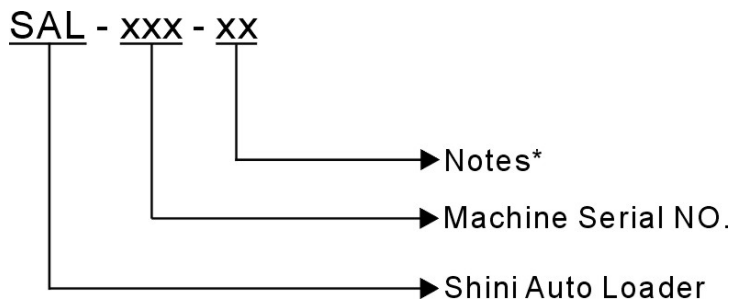

Note:*

P=For Polished Hopper Inside CE=CE Conformity

1.2 Main Features

- Stainless steel hopper, motor overload protective device.
- SAL-430/460 has standard cloth mesh filter and motor reverse cleaning function.

1.3 Accessory option

- Buzzer is an optional selection.
- Manual control switch is optional.
- Quick mixing valve can be opted to work with proportional valve to enhance mixing effect.

All service work should be carried out by a person with technical training or corresponding professional experience. The manual contains instructions for both handling and servicing.

Any modifications of the machine must be approved by SHINI in order to avoid personal injury and damage to machine. We shall not be liable for any damage caused by unauthorized change of the machine.

Our company provides excellent after-sales service. Should you have any problem during using the machine, please contact the company or the local vendor.

Headquarter and Taipei factory:

Tel: (886) 2 2680 9119

Shini Plastics Technologies (Dongguan), Inc:

Tel: (86) 769 8111 6600

Shini Plastics Technologies India Pvt.Ltd.:

Tel: (91) 250 3021 166

1.4 Technical Specifications

1.4.1 Outer Dimensions

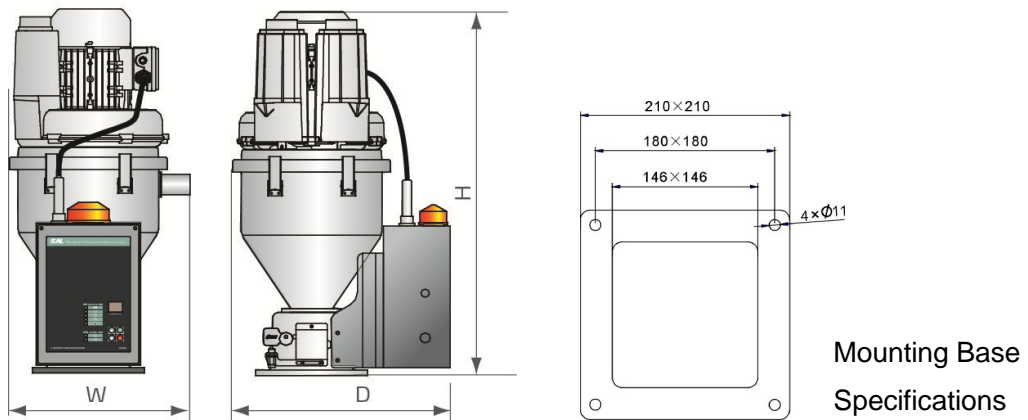

Picture 1-1: Outer Dimensions

Table 1-1: Specifications

Model	SAL-430	SAL-460
Ver.	A	A
Type	Inductive	
Blower power (kW) (50/60Hz)	0.37	0.75
Conveying pipe dia(Inch)	1.5	1.5
*Conveying capacity(kg/hr, 50Hz/60Hz)	200/220	300/330
Hopper capacity (L)	3	6
Input voltage	3Φ,400VAC,50Hz	
Material level control	Microswitch	
Cloth filter	Standard	
Auto-cleaning	Standard	
Dimensions		
H(mm)	660	735
W(mm)	310	350
D(mm)	395	420
Weight (kg)	23	26

Note: 1) For hopper inside polished ones, add "P" at model behind.

2) Test condition of conveying capacity: Plastic material of bulk density 0.65kg/L, dia. 3~5 mm, vertical conveying height: 4m, horizontal conveying distance: 1m.V.

1.4.2 Loading Capacity

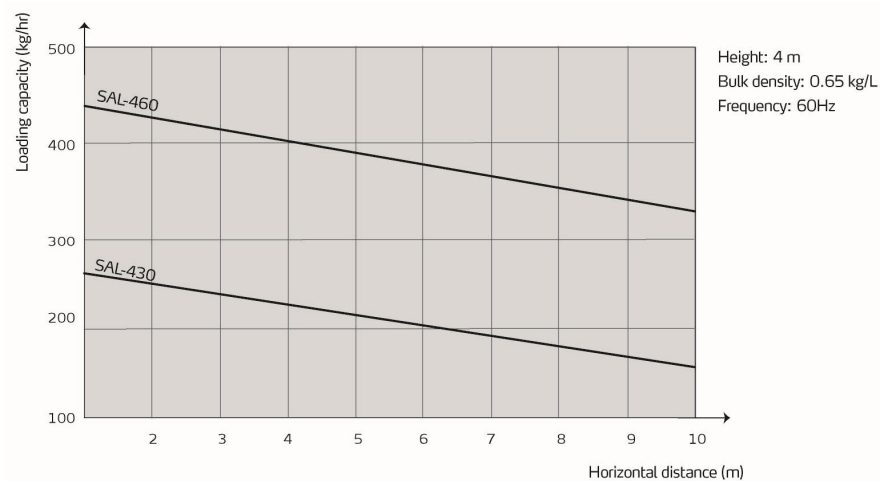

Picture 1-2: Loading Capacity

1.5 Safety Regulations

Please abide by the safety guide when you operate the machine so as to prevent damage of the machine and personal injuries.



All electrical components should be installed by qualified electricians.
Turn off main switch and control switch during repair and maintenance.



Warning! High voltage!
This mark is attached on the cover of the control box.



Warning! Be careful!
Be more careful when this mark appears.

Transportation

- 1) SAL series hopper loader are packed in paper cartons. Handle with care when to move the machine by hands.
- 2) Do not rotate the machine and avoid collision with other objects during transportation to prevent improper functioning.
- 3) The structure of the machine is well-balanced, although it should also be handled with care when lifting the machine for fear of falling down.
- 4) The machine and its attached parts can be kept at a temperature from -25°C to $+55^{\circ}\text{C}$ for long distance transportation and for a short distance, it can be transported with temperature under $+70^{\circ}\text{C}$.

Storage

- 1) SAL series hopper loader should be stored indoors with temperature kept from 5°C to 40°C and humidity below 80%.
- 2) Disconnect all power supply and turn off main switch and control switch.
- 3) Keep the whole machine, especially the electrical components away from water to avoid potential troubles caused by the water.
- 4) Plastic film should be used to protect the machine from dust and rains.

Working Environment

The machine should be operated:

Indoors in a dry environment with max. temperature +45°C and humidity no more than 80%.

Do not use the machine

- 1) If it is with a damaged cord.
- 2) On a wet floor or when it is exposed to rain to avoid electrical shock.
- 3) If it has been dropped or damaged until it is checked or fixed by a qualified serviceman.
- 4) This equipment works normally in the environment with altitude within 3000m.
- 5) At least a clearance of 1m surrounding the equipment is required during operation. Keep this equipment away from flammable sources at least two meters.
- 6) Avoid vibration, magnetic disturbance at the operation area.

Rejected Parts Disposal

When the equipment has run out its life time and can not be used any more, unplug the power supply and dispose of it properly according to local code.

Fire hazard



In case of fire, CO₂ dry powder fire extinguisher should be applied.

1.6 Exemption Clause

The following statements clarify the responsibilities and regulations born by any buyer or user who purchases products and accessories from Shini (including employees and agents).

Shini is exempted from liability for any costs, fees, claims and losses caused by reasons below:

1. Any careless or man-made installations, operation and maintenances upon machines without referring to the manual prior to machine using.
2. Any incidents beyond human reasonable controls, which include man-made vicious or deliberate damages or abnormal power, and machine faults caused by irresistible natural disasters including fire, flood, storm and earthquake.

3. Any operational actions that are not authorized by Shini upon machine, including adding or replacing accessories, dismantling, delivering or repairing.
4. Employing consumables or oil media that are not appointed by Shini.

2. Structure Characteristics and Working Principle

SAL-430 / 460 series are suitable for conveying plastic granules. The blower makes vacuum of material hopper by drawing the air out. Materials will then be sent into material hopper.

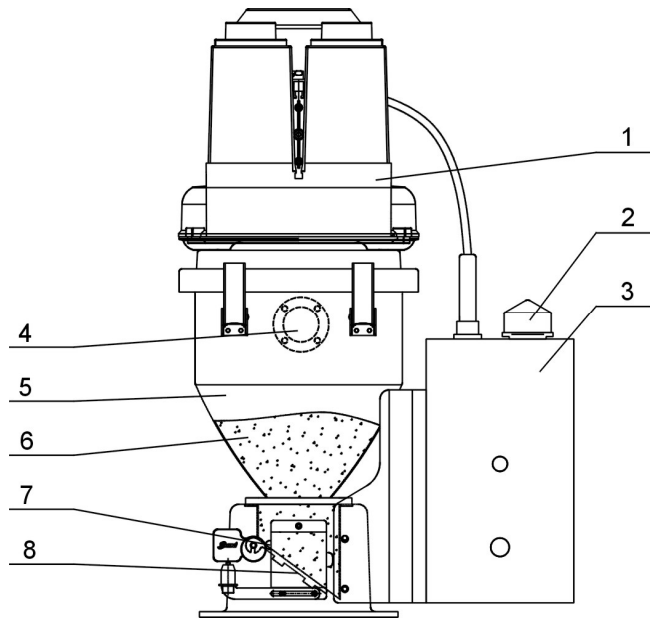

Picture 2-1: Working Principle

- | | |
|-------------------|------------------------|
| 1. Blower | 2. Alarm light |
| 3. Control box | 4. Material inlet pipe |
| 5. Storage hopper | 6. Materials |
| 7. Microswitch | 8. Discharging plate |

After starting the machine, blower(1) works, it makes the storage hopper(5) generate the vacuum, discharging plate(8) closed, materials in the silo enter into the storage hopper(5) through material inlet pipe (4) by air pressure difference. When loading is finished, blower(1) stops rotating, materials(6) drop off by gravity, when microswitch(7) detected there's no material in the hopper, blower(1) will start again. When material can't be sucked or lack of material, alarm light (2) on control box (3) will flicker for indication.

3. Assembly Drawing

3.1 Assembly Drawing (SAL-430)

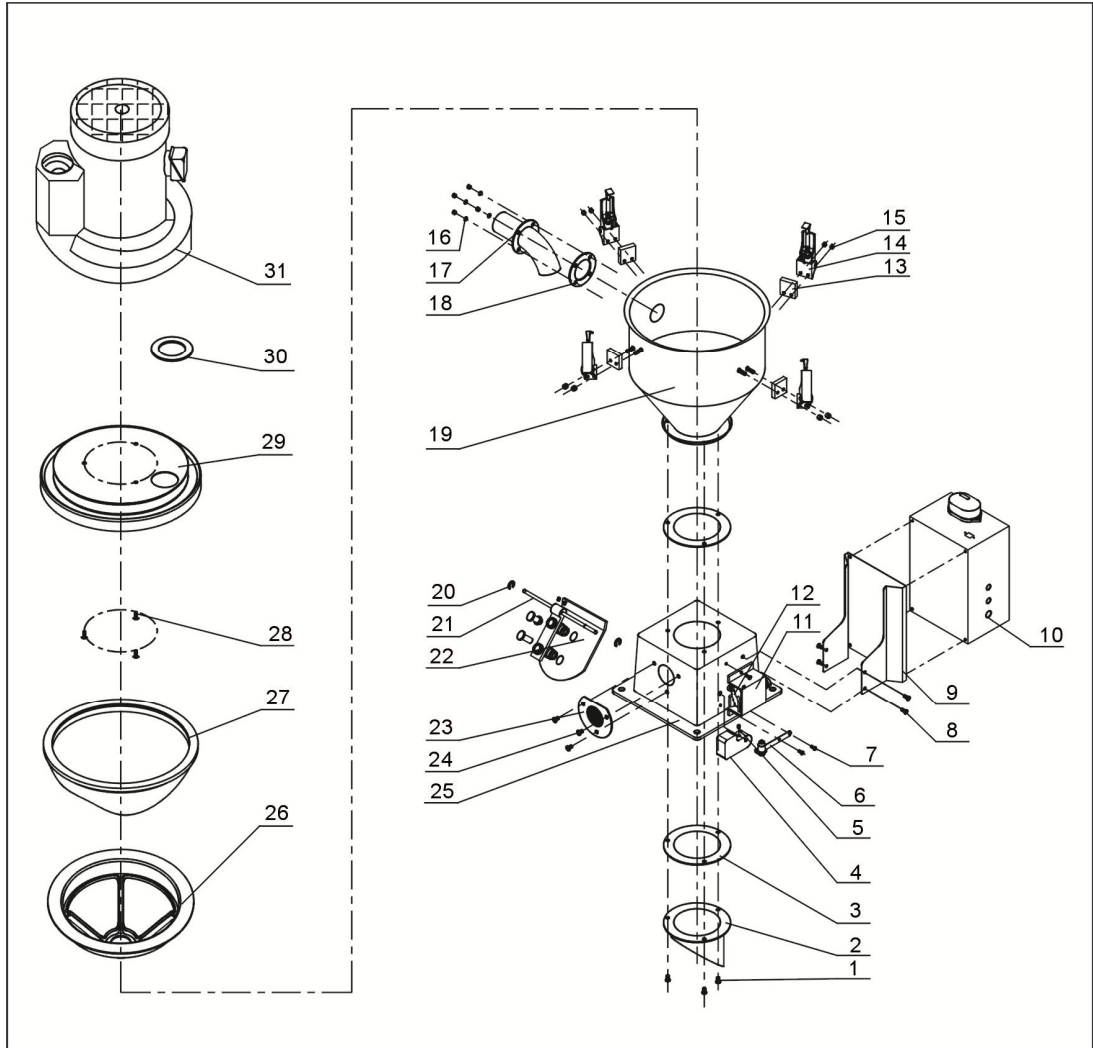

Remarks: Please refer to material list 3.2 for specific explanation of the Arabic numbers in parts drawing.

Picture 3-1: Assembly Drawing (SAL-430)

3.2 Parts List (SAL-430)

Table 3-1: Parts List

NO.	Past Name	Part NO.
1	Cross recessed pan head screw M5×20	YW62041200000
2	Discharge port	BL20333600020
3	Base seal	YR10000000600
4	Counter weight hammer	YW20602100000
5	Set screw M5×5	YW68005500000
6	Ejector rob	BH10000600050
7	Cross recessed pan head screw M4×10	YW63041000000
8	Cross recessed pan head screw M5×10	YW62051000100
9	Fixed plate of control box	-
10	Control box	-
11	Microswitch box	YR40330900000
12	Microswitch*	YE14511200000
13	Snap hook pressure block	YR40000600300
14	Snap hook	YW02003000400
15	Hexagon locknut M4×0.7	YW64040700100
16	Flat gasket 4	YW64040700100
17	Material inlet pipe	BL20006005520
18	Material inlet pipe seal	R10150300000
19	Material storage tank	-
20	E-rings	YW66000500000
21	Pontil	BH10061400040
22	Discharging plate	-
23	Air vent window	YR40002400000
24	Cross recessed pan head screw M6×10	YW62061000000
25	Square base	BA10046000010
26	Split washer of filter cloth*	YR40003000100
27	Filter bag*	BP82003000044
28	Cross recessed pan head screw M6×15	YW62061500000
29	Hopper cover	-
30	Air inlet fastener	YR10040000000
31	Blower 0.37kW**	BM30020500150

* means possible broken parts. ** means easy broken part. and spare backup is suggested.

Please confirm the version of manual before placing the purchase order to guarantee that the item number of the spare part is in accordance with the real object.

3.3 Assembly Drawing (SAL-460)

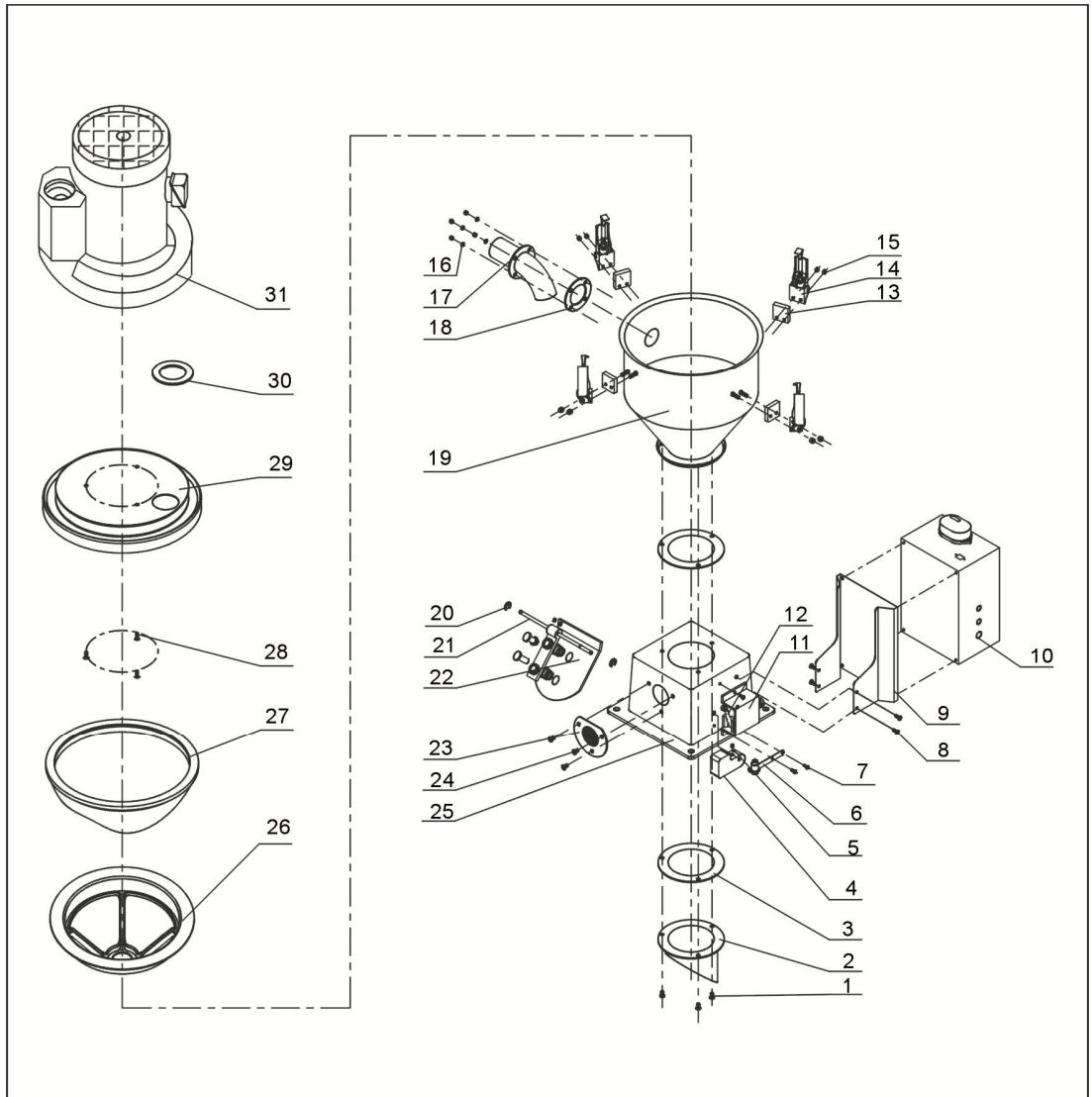

Remarks: Please refer to material list 3.4 for specific explanation of the Arabic numbers in parts drawing.

Picture 3-2: Assembly Drawing (SAL-460)

3.4 Parts List (SAL-460)

Table 3-2: Parts List

NO.	Past Name	Part NO.
1	Cross recessed pan head screw M5×20	YW62041200000
2	Discharge port	BL20333600020
3	Base seal	YR10000000600
4	Counter weight hammer	YW20602100000
5	Set screw M5×5	YW68005500000
6	Ejector rob	BH10000600050
7	Cross recessed pan head screw M4×10	YW63041000000
8	Cross recessed pan head screw M5×10	YW62051000100
9	Fixed plate of control box	-
10	Control box	-
11	Microswitch box	YR40330900000
12	Microswitch*	YE14511200000
13	Snap hook pressure block	YR40000600300
14	Snap hook	YW02003000400
15	Hexagon locknut M4×0.7	YW64040700100
16	Flat gasket 4	YW66040800000
17	Material inlet pipe	BL32000600020
18	Material inlet pipe seal	YR10061200000
19	Material storage tank	-
20	E-rings	YW66000500000
21	Pontil	BH10061400040
22	Discharging plate	-
23	Air vent window	YR40002400000
24	Cross recessed pan head screw M6×10	YW62061000000
25	Square base	BA10046000010
26	Split washer of filter cloth*	YR40006000000
27	Filter bag*	BP82006000044
28	Cross recessed pan head screw M6×15	YW62061500000
29	Hopper cover	-
30	Air inlet fastener	YR10040000000
31	Blower 0.75kW**	BM30031000050

* means possible broken parts. ** means easy broken part. and spare backup is suggested.

Please confirm the version of manual before placing the purchase order to guarantee that the item number of the spare part is in accordance with the real object.

4. Electrical Circuit Diagram

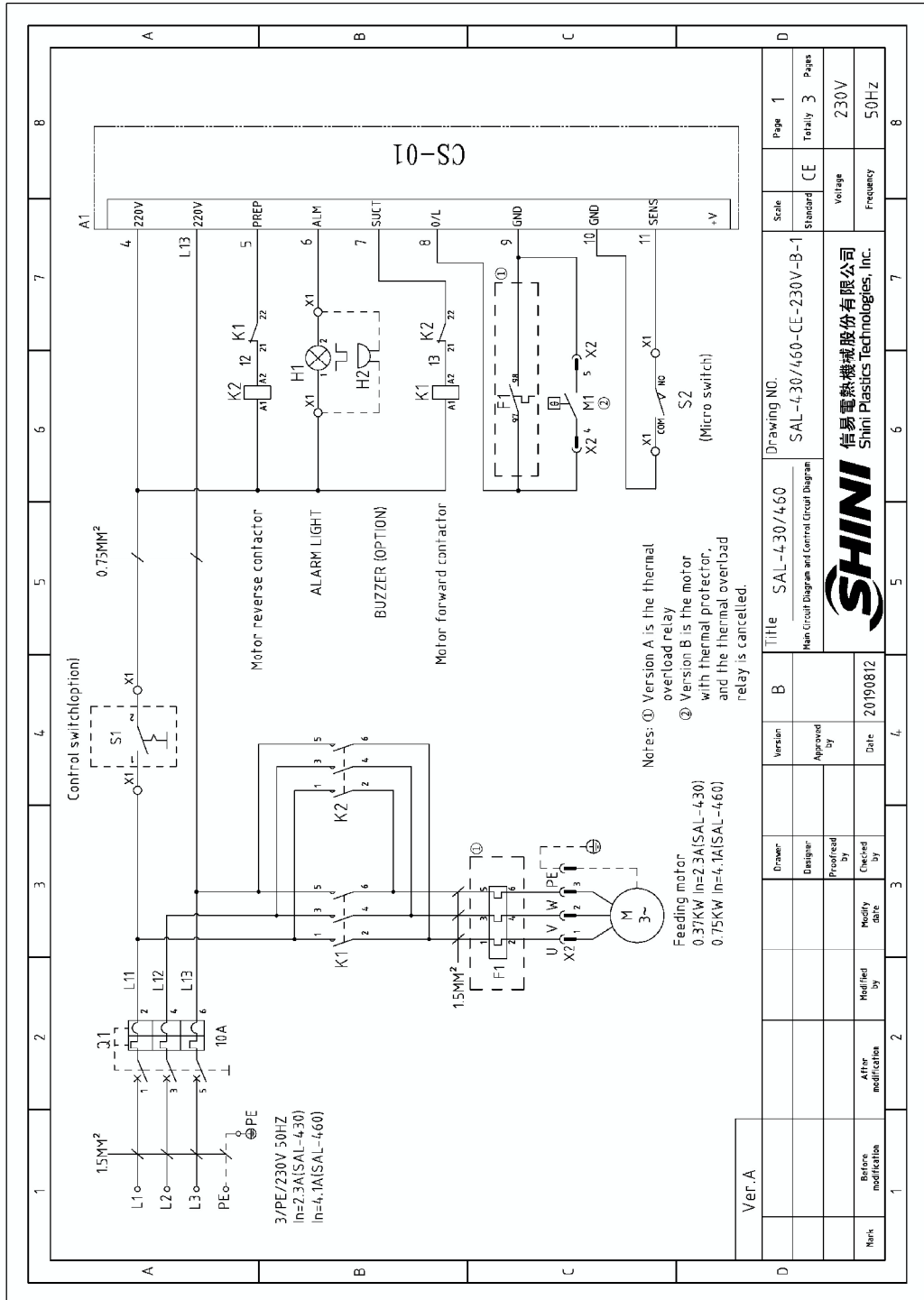

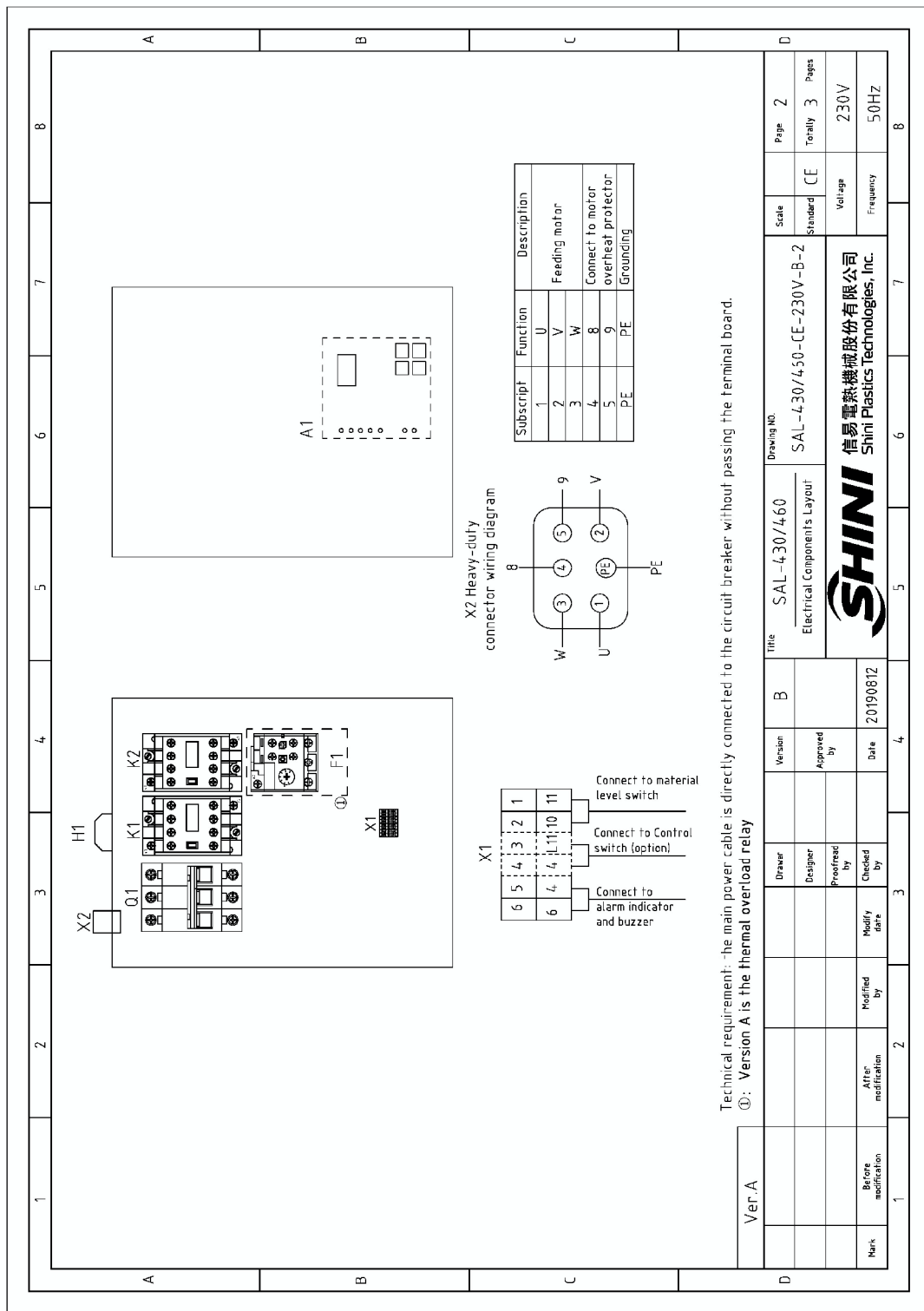

Ver.A	Drawer	Version	B	Title	SAL-430/460	Drawing NO.	SAL-430/450-CE-230V-B-2	Scale	Standard	Page	2
	Designer	Approved by		Electrical Components Layout				Standard	CE	Totally	3
	Proofread by	Date	20190812					Voltage	230V	Pages	
Mark	Before modification	After modification	Modify date					Frequency	50HZ		

1	2		3	4	5	6	7	8
No.	Symbol	Name	Manufacturer	Type	Specification	Number	Material number	Remark
1	Q1	Circuit Breaker	TECO	BM-63C/30T0S	10A	1	YE40301003000	
2	K1 K2	AC Contactor	SCHNEIDER	LC1-D09MT220V	230V 50/60HZ	2	YE00109700100	
3	F1	Thermo overload relay	SCHNEIDER	LRD-08C	2.5-4A	1	YE01025400600	①
4	S1	Control Switch	SHINI	303	250VAC 10A	1	YE10030300000	(2)
5	S2	Micro switch	JUCHE	LXW5-11G2	250V 10A	1	YE14511200000	(1)
6	H1	Alarm Light	SHINI	LTE-3051	230VAC 50/60HZ	1	YE83305100200	
7	H2	Buzzer	TEND	PF-35A	230VAC 50/60HZ	1	YE84003500000	(3)
8	A1	Microcomputer Mainboard	YUYUN	CS-01	230VAC 50/60HZ	1	YE80122000000	
9	X1	Connection terminal	HONEYWELL	SK2.5	2.5mm ²	4	YE60002503200	(2)
10		Connection terminal	HONEYWELL	SK2.5	2.5mm ²	2	YE60002503200	
11		Terminal fittings E/GK series	HONEYWELL	---	PCS	4	YE60000003900	
12	X2	Heavy duty connector	HARTING	5P+PE(socket)	Han Q5/0-F	1	YE68000501400	
13	M	Motor	SHINI	---	0.5HP	1	---	(1)SAL-430
14		Motor	SHINI	---	1HP	1	---	(1)SAL-460
B								
C								
D								
Ver. A Note: (1) Means not part of control box. (2) Optional manual control switch. (3) Means it's equipped with buzzer. (4) Version A is the thermal overload relay								
			Drawer	Version	Title		Scale	
			Designer	Approved by	SAL-430/460		Page 3	
			Prepared by		Electrical Component's List		Standard CE	
			Checked by	Date	SAL-430/460-CE-230V-B-3		Totally 3 Pages	
			Modify date	20190812	SHINI 信易電熱機械股份有限公司 Shini Plastics Technologies, Inc.		Voltage 230V	
			Modified by				Frequency 50-Hz	
			Mark					
1	2		3	4	5	6	7	8

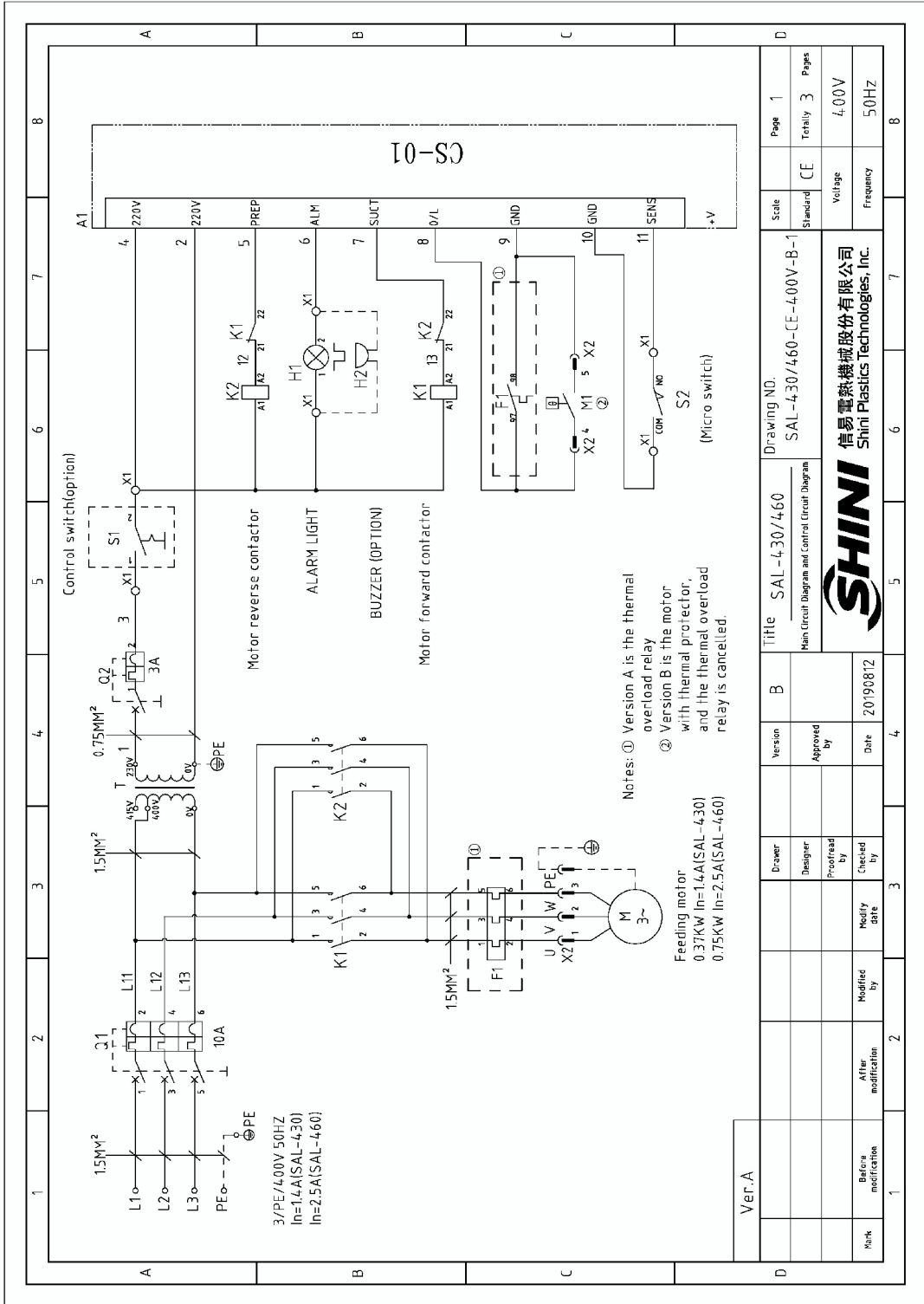

1	2	3	4	5	6	7	8
Ver.A				Title		Drawing NO.	
		Version		SAL-430/460		SAL-430/460-CE-400V-B-1	
		Designer		Main Circuit Diagram and Control Circuit Diagram		Scale	
		Approved by				Standard	
		Checked by				Voltage	
		Modify date				Frequency	
		After modification				400V	
		Modified by				50HZ	
		Checked by				Page 1	
		Date				Totally 3	
		20190812				Pages	
						400V	
						50HZ	

SHINI 信易電熱機械股份有限公司
 Shini Plastics Technologies, Inc.



1	2	3	4	5	6	7	8																					
					<table border="1" style="width: 100%; border-collapse: collapse;"> <thead> <tr> <th>Subscript</th> <th>Function</th> <th>Description</th> </tr> </thead> <tbody> <tr><td>1</td><td>U</td><td></td></tr> <tr><td>2</td><td>V</td><td>Feeding motor</td></tr> <tr><td>3</td><td>W</td><td></td></tr> <tr><td>4</td><td>8</td><td>Connect to motor overheat protector</td></tr> <tr><td>5</td><td>9</td><td></td></tr> <tr><td>PE</td><td>PE</td><td>Grounding</td></tr> </tbody> </table>			Subscript	Function	Description	1	U		2	V	Feeding motor	3	W		4	8	Connect to motor overheat protector	5	9		PE	PE	Grounding
Subscript	Function	Description																										
1	U																											
2	V	Feeding motor																										
3	W																											
4	8	Connect to motor overheat protector																										
5	9																											
PE	PE	Grounding																										
Ver.A Technical requirement: the main power cable is directly connected to the circuit breaker without passing the terminal board. ①: Version A is the thermal overload relay				Title: SAL-430/460 Electrical Components Layout		Drawing No. SAL-430/460-CE-400V-B-2 Scale: Standard Voltage: 400V Frequency: 50HZ																						
<table border="1" style="width: 100%; border-collapse: collapse;"> <thead> <tr> <th>Mark</th> <th>Before modification</th> <th>After modification</th> <th>Modified date</th> <th>Checked by</th> <th>Date</th> </tr> </thead> <tbody> <tr> <td style="text-align: center;">1</td> <td></td> <td></td> <td></td> <td></td> <td></td> </tr> </tbody> </table>				Mark	Before modification	After modification	Modified date	Checked by	Date	1						<table border="1" style="width: 100%; border-collapse: collapse;"> <thead> <tr> <th>Version</th> <th>Approved by</th> <th>Date</th> </tr> </thead> <tbody> <tr> <td style="text-align: center;">B</td> <td></td> <td style="text-align: center;">20190812</td> </tr> </tbody> </table>		Version	Approved by	Date	B		20190812	 信易電熱機械股份有限公司 Shini Plastics Technologies, Inc.	Page 2 Totally 3 400V 50HZ			
Mark	Before modification	After modification	Modified date	Checked by	Date																							
1																												
Version	Approved by	Date																										
B		20190812																										
A	B	C	Ver.A 信易電熱機械股份有限公司 Shini Plastics Technologies, Inc.																									

1		2		3		4		5		6		7		8	
NC.	Symbol	Name	Manufacturer	Type	Specification	Number	Material number	Remark							
1	Q1	Circuit Breaker	TECO	BM-63C/30T0S	10A	1	YE40301003000								
2	K1 K2	AC Contactor	SCHNEIDER	LC1-D09MT220V	230V 50/60HZ	2	YE00109700100								
3	F1	Thermo overload relay	SCHNEIDER	LRD-08C	2.5-4A	1	YE01025400600	①							
4	T	Sensor Transformer	JIUXIN	IN=400V/415V OUT=230V	300mA	1	YE70040005000								
5	Q2	Circuit Breaker	TECO	BM-63C/1003S	3A IP	1	YE40100203000								
6	S1	Control Switch	SHINI	303	250VAC 10A	1	YE10030300000	{2}							
7	S2	Micro Switch	JUCHE	LXW5-11G2	250V 10A	1	YE14511200000	{1}							
8	H1	Alarm Light	SHINI	LTE-3051	230VAC 50/60HZ	1	YE83305100200								
9	H2	Buzzer	TEND	PF-35A	230VAC 50/60HZ	1	YE84003500000	{3}							
10	A1	Microcomputer Mainboard	YUYUN	CS-01	230VAC 50/60HZ	1	YE80122000000								
B		X1	Connection terminal	HONEYWELL	SK2.5	4	YE60002503200	{2}							
B		X2	Connection terminal	HONEYWELL	SK2.5	2	YE60002503200	{2}							
B		X3	Terminal fittings E/Gk series	HONEYWELL	---	4	YE600000003900								
B		X4	Heavy duty connector	HARTING	5P+PE(Socket)	1	YE68000501400								
B		M1	Motor	SHINI	---	1	---	{1}SAL-430							
B		M2	Motor	SHINI	---	1	---	{1}SAL-460							
C															
C															
D		VER.A	Note: {1} Means not part of control box. {2}Optional manual control switch. {3}Means it's equipped with buzzer. ①: Version A is the thermal overload relay												
D			Drwer	Version	Scale	Page									
D			Designer	Approved by	Standard	Totally									
D			Prepared by	Date	CE	Voltage									
D			Checked by		Frequency										
D			Modified by												
D		Mark	After modification	Modify date											
D		1													

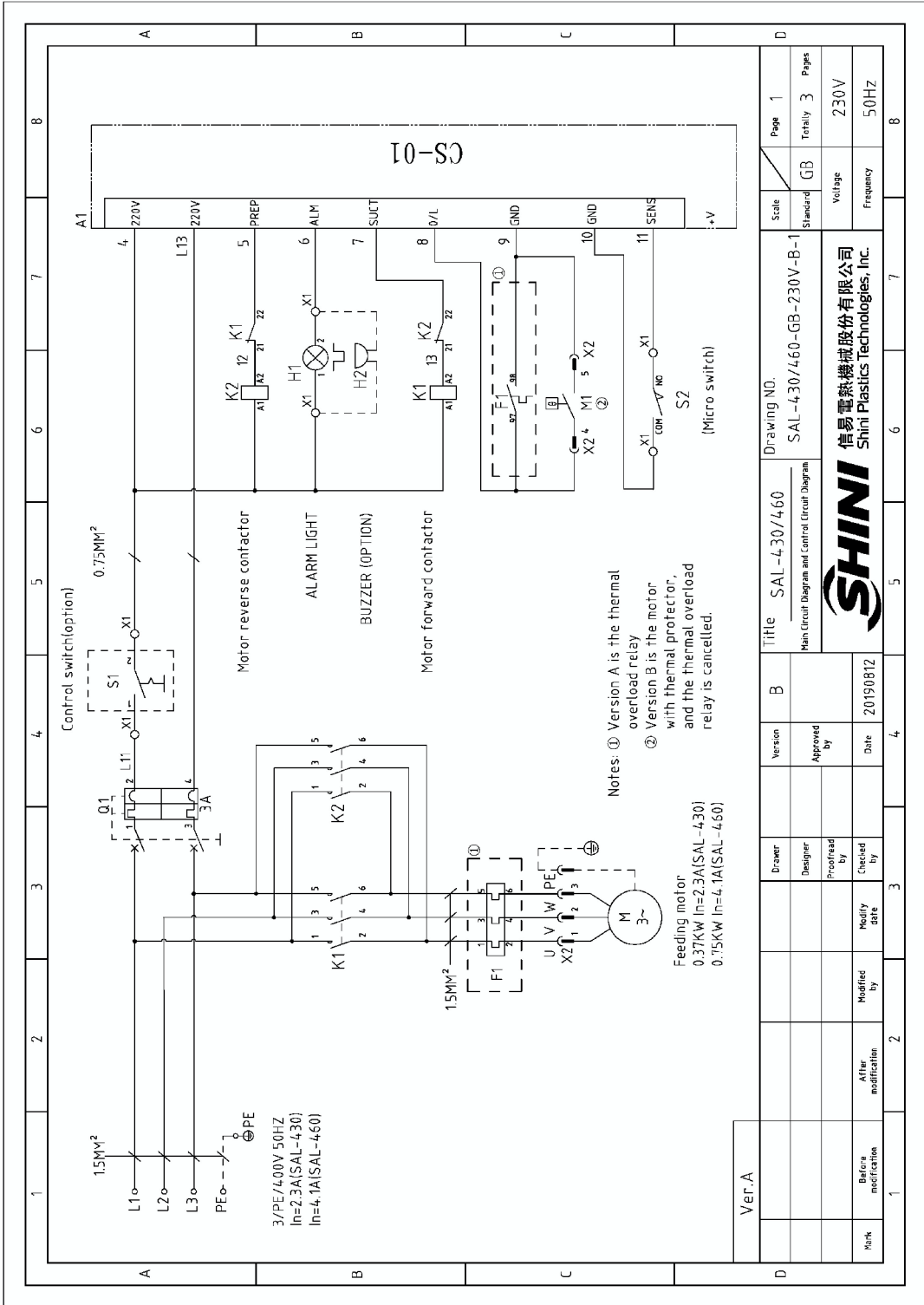

 SHINI 4.30/4.60
 SAL-4.30/4.60-CE-4.00V-B-3
 信易電熱機械股份有限公司
 Shini Plastics Technologies, Inc.

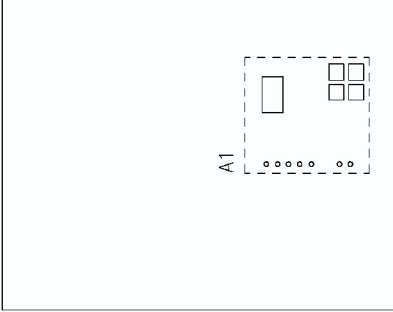
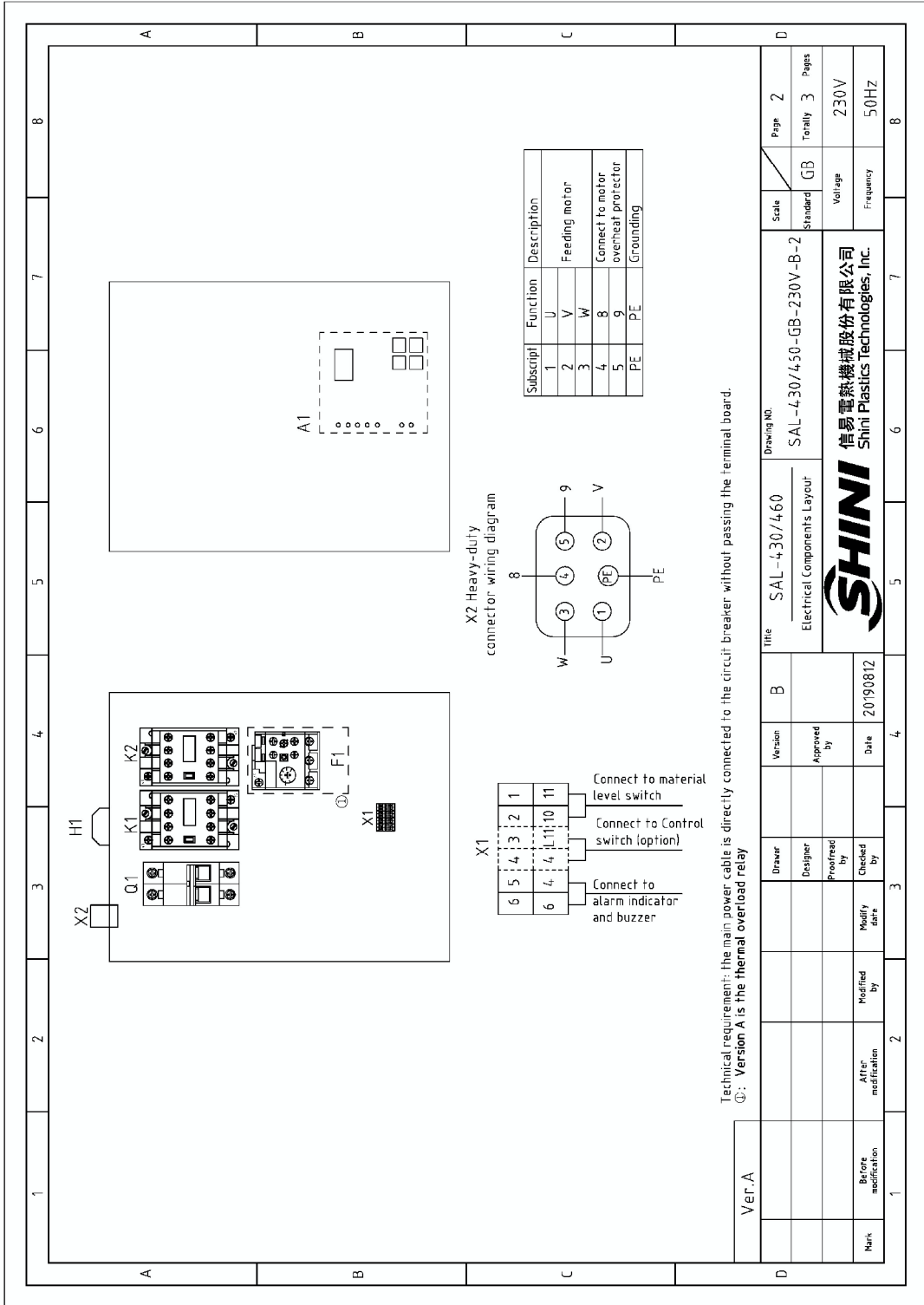

Ver.A		Title		Drawing NO.		Scale		Page 1	
		SAL-430/460		SAL-430/460-GB-230V-B-1		Standard GB		Totally 3	
		Main Circuit Diagram and Control Circuit Diagram				Voltage 230V			
		Version		Date		Frequency 50HZ			
		Approved by		20190812					
		Checked by							
		Modified by							
		After modification							
		Before modification							
		Mark							

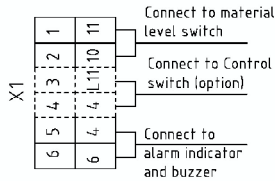
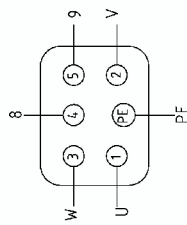

X2 Heavy-duty connector wiring diagram



Subscript	Function	Description
1	U	Feeding motor
2	V	Feeding motor
3	W	Feeding motor
4	8	Connect to motor overheat protector
5	9	Connect to motor overheat protector
PE	PE	Grounding

Technical requirement: the main power cable is directly connected to the circuit breaker without passing the terminal board.
 ①: Version A is the thermal overload relay

Ver.A									
Drawn									
Designer									
Proofread by									
Checked by									
Modified by									
Modify date									
Mark	Before modification	After modification							

Page	2	Scale	Standard	Drawing NO.	SAL-430/460	Version	B	Title	SAL-430/460 Electrical Component's Layout	Standard	GB	Totally	3	Pages
Volage	230V	Frequency	50HZ	Standard	GB	Approved by		Electrical Component's Layout		Standard	GB	Totally	3	Pages
SHINI 信易電熱機械股份有限公司 Shini Plastics Technologies, Inc.										Standard	GB	Totally	3	Pages
Mark	Before modification	After modification				Date	20190812			Standard	GB	Totally	3	Pages

1	2	3	4	5	6	7	8	
NO.	Symbol	Name	Manufacturer	Type	Specification	Number	Material number	Remark
1	Q1	Circuit Breaker	TECO	BM-63C/20035	3A, 2P	1	YE40200203000	
2	K1 K2	AC Contactor	SCHNEIDER	LC1-D09MT220V	230V 50/60HZ	2	YE00109700100	
3	F1	Thermo overload relay	SCHNEIDER	LRD-08C	2.5-4A	1	YE01025400600	①
4	S1	Control Switch	SHINI	303	250VAC 10A	1	YE10030300000	②
5	S2	Micro Switch	JUCHE	LXW5-11G2	250V 10A	1	YE14511Z00000	①
6	H1	Alarm Light	SHINI	LTE-305T	230VAC 50/60HZ	1	YE88300510200	
7	H2	Buzzer	TEND	PF-35A	230VAC 50/60HZ	1	YE84003500000	③
8	A1	Microcomputer Mainboard	YUYUN	CS-01	230VAC 50/60HZ	1	YE80122000000	
9	X1	Connection terminal	HONEYWELL	SK2.5	2.5mm ²	4	YE60002503200	
10		Connection terminal	HONEYWELL	SK2.5	2.5mm ²	2	YE60002503200	②
11		Terminal fittings E/Gk series	HONEYWELL	---	PCS	4	YE60000003900	
12	X2	Heavy duty connector	HARTING	5P+PE(Socket)	Han Q5/0-F	1	YE68000501400	
13	M	Motor	SHINI	---	0.5HP	1	---	①SAL-430
		Motor	SHINI	---	1HP	.	---	①SAL-460

Ver-A	Note: ① Means not part of control box. ② Optional manual control switch. ③ Means it's equipped with buzzer. ④: Version A is the thermal overload relay																																				
D	<table border="1"> <tr> <td>Drawer</td> <td>Designer</td> <td>Version</td> <td>B</td> </tr> <tr> <td></td> <td></td> <td>Approved by</td> <td></td> </tr> <tr> <td></td> <td></td> <td>Checked by</td> <td></td> </tr> <tr> <td></td> <td></td> <td>date</td> <td>20190812</td> </tr> </table>	Drawer	Designer	Version	B			Approved by				Checked by				date	20190812	<table border="1"> <tr> <td>Scale</td> <td>Page</td> </tr> <tr> <td>Standard</td> <td>Totally</td> </tr> <tr> <td>GB</td> <td>3</td> </tr> <tr> <td colspan="2">Electrical Components List</td> </tr> <tr> <td>SAL-430/460</td> <td>3</td> </tr> <tr> <td colspan="2">SHINI 信易電熱機械股份有限公司</td> </tr> <tr> <td colspan="2">Shini Plastics Technologies, Inc.</td> </tr> </table>	Scale	Page	Standard	Totally	GB	3	Electrical Components List		SAL-430/460	3	SHINI 信易電熱機械股份有限公司		Shini Plastics Technologies, Inc.		<table border="1"> <tr> <td>Voltage</td> <td>230V</td> </tr> <tr> <td>Frequency</td> <td>50Hz</td> </tr> </table>	Voltage	230V	Frequency	50Hz
Drawer	Designer	Version	B																																		
		Approved by																																			
		Checked by																																			
		date	20190812																																		
Scale	Page																																				
Standard	Totally																																				
GB	3																																				
Electrical Components List																																					
SAL-430/460	3																																				
SHINI 信易電熱機械股份有限公司																																					
Shini Plastics Technologies, Inc.																																					
Voltage	230V																																				
Frequency	50Hz																																				

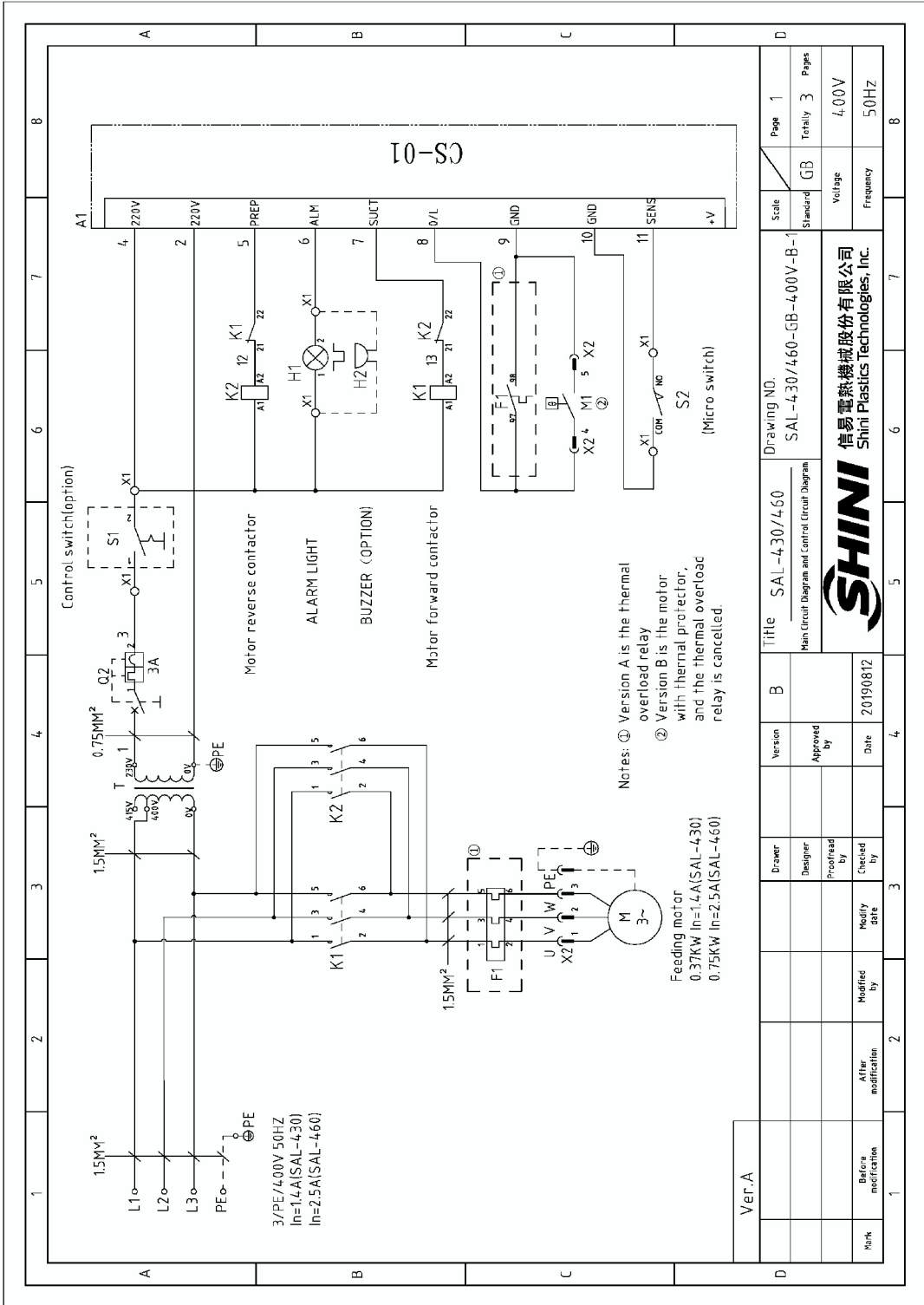

Scale	Standard	GB	Page 1	Totally 3	Pages
Voltage	4.00V				
Frequency	5.0HZ				
Title		SAL-430/460		Drawing NO.	
Main Circuit Diagram and Control Circuit Diagram		SAL-430/460-GB-4.00V-B-1		Ver.A	
Version	B	Approved by			
Checked by	20190812	Date			
Modified by		Modify date			
Before modification					
After modification					

SHINI
 信易電熱機械股份有限公司
 Shini Plastics Technologies, Inc.

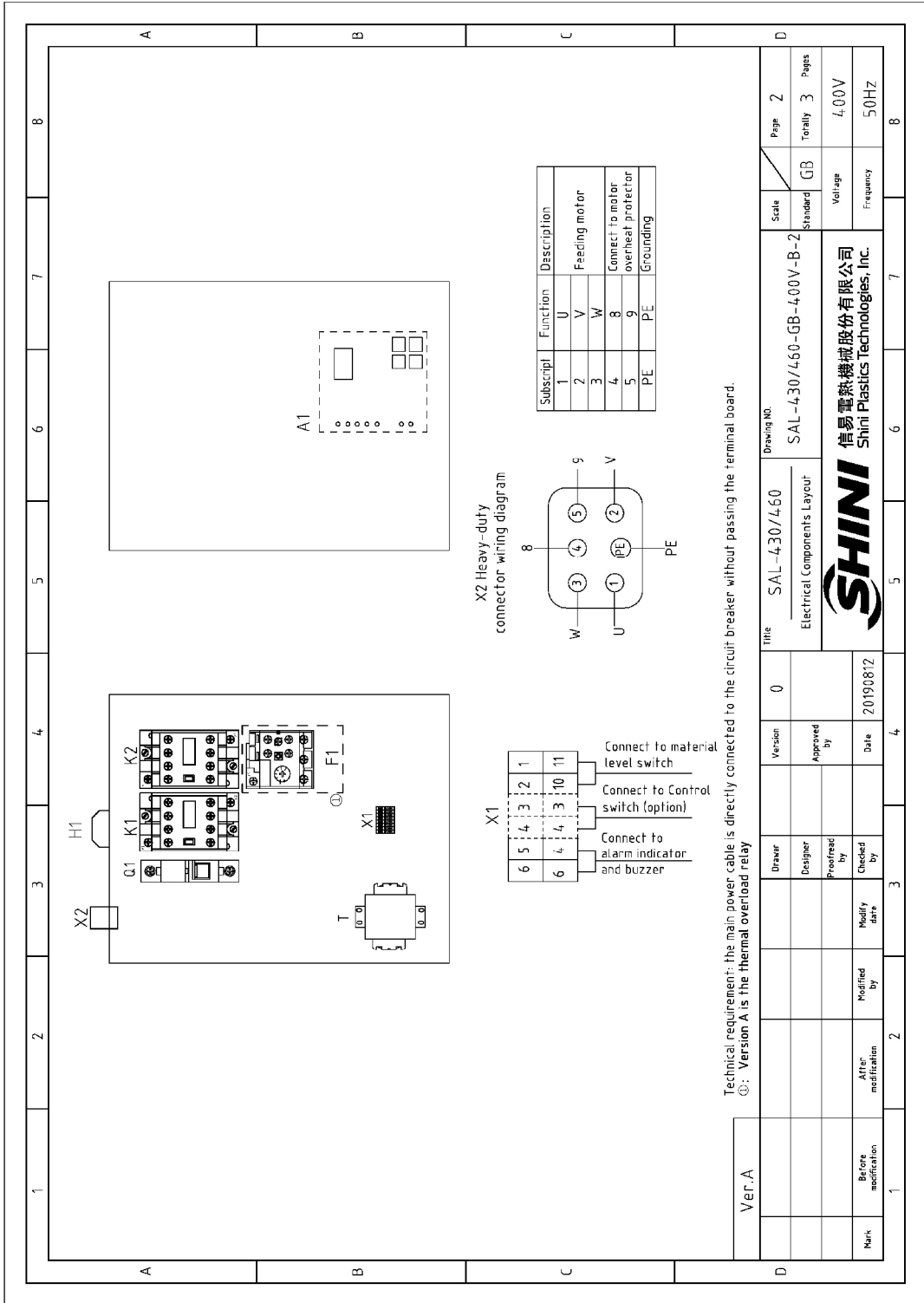

Technical requirement: the main power cable is directly connected to the circuit breaker without passing the terminal board.

⊙: Version A is the thermal overload relay

VER.A									
Mark	Before modification	After modification	Modified by	Modify date	Checked by	Specified by	Designer	Drawer	Version

0	SAL-430/460	0							
Electrical Components Layout	SAL-430/460-GB-4.00V-B-2		Scale	Standard	GB	Page	2	Totally	3
SHINI 信易電熱機械股份有限公司 Shini Plastics Technologies, Inc.			Voltage	4.00V		Frequency	5.0HZ		

1	2		3	4	5	6	7	8
NC.	Symbol	Name	Manufacturer	Type	Specification	Number	Material number	Remark
1	K1 K2	AC Contactors	SCHNEIDER	LC1-D09MT220V	230V 50/60HZ	2	YE00109700100	
2	F1	Thermo overload relay	SCHNEIDER	LRD-08C	2.5-4A	1	YE01025400600	①
3	T	Sensor Transformer	JIUJIN	IN=400V/4.15V OUT=230V	300mA	1	YE7004.0005000	A
4	Q1	Circuit Breaker	TECO	BM-63C/1003S	3A 1P	1	YE40100203000	
5	S1	Control Switch	SHINI	303	250VAC 10A	1	YE10030300000	{2}
6	S2	Micro Switch	JUCHE	LXW5-11G2	250V 10A	1	YE14511200000	{1}
7	H1	Alarm Light	SHINI	LTE-3051	230VAC 50/60HZ	1	YE83305100200	
8	H2	Buzzer	TEND	PF-35A	230VAC 50/60HZ	1	YE84003500000	{3}
9	A1	Microcomputer Mainboard	YUYUN	CS-01	230VAC 50/60HZ	1	YE80122000000	
10	X1	Connection terminal	HONEYWELL	SK2.5	2.5mm ²	4	YE60002503200	
11		Connection terminal	HONEYWELL	SK2.5	2.5mm ²	2	YE60002503200	{2}
12		Terminal fittings E/GK series	HONEYWELL	---	PCS	4	YE60000003900	
13	X2	Heavy duty connector	HARTING	5P+PE(socket)	Han Q5/0-F	1	YE680005014.00	
14	M	Motor	SHINI	---	0.5HP	1	---	{1}SAL-430
15		Motor	SHINI	---	1HP	1	---	{1}SAL-460
B								
C								
D								
Ver-A			Note: {1} Means not part of control box. {2}Optional manual control switch. {3}Means it's equipped with buzzer. ①: Version A is the thermal overload relay		Title		Scale	
			B		SAL-430/460		Page 3	
Drawer			Version		Drawing NO.		Standard	
Designer			Approved by		SAL-430/460-GB-4.00V-B-3		GB	
Prepared by			Date		Electrical Components List		Voltage	
Checked by			20190812		SHINI 信易電熱機械股份有限公司		4.00V	
Modified by			Modify date		SHINI 信易電熱機械股份有限公司		Frequency	
Before modification					SHINI 信易電熱機械股份有限公司		50-Hz	
1	2		3	4	5	6	7	8

4.1 Main Electrical Components Description

4.1.1 Microswitch

It is used to give control signals to make the motor start working after discharge of the material.

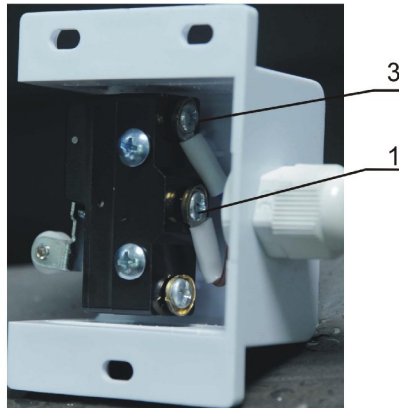

Picture 4-1: Photoelectrical Sensor

1. 3: To be connected with signal wires

5. Installation and Debugging

This series of models only could be applied in working environment with good ventilation.

Make a careful study of this chapter before installation. The machine must be installed according to the steps below.

Power supply should be connected by qualified electricians.

5.1 Installation of SAL-430 / 460

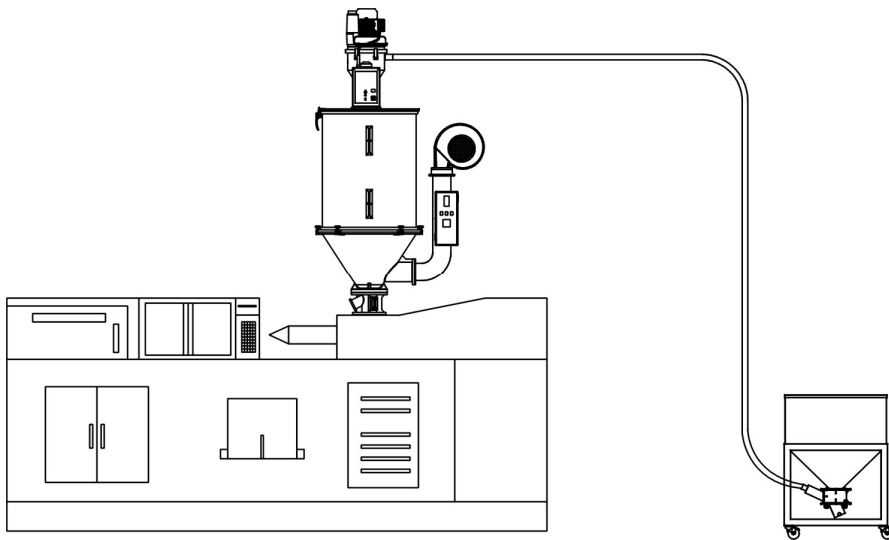

Picture 5-1: Installation Methods (SAL-430/460)

1. Notes for Installation and Positioning

- 1) Machine just can be mounted in vertical position. Make sure there's no pipe, fixed structure or other objects above the installing location and around the machine which may block machine's installation, hit objects or injure human person.
- 2) For easy maintenance, it's suggested to leave 1m space around the machine.
- 3) Machine should be placed on water-level surface. If it needs to be mounted on a higher surface (e.g. the scaffold or the interlayer), should ensure its structure and size could bear the weight and size of the machine.

2. Pipe connection

As picture, mount the loader onto the hopper dryer and lock with screws. Connect one end of the material pipe to inlet of loader and insert another side to the storage tank.

3. Electrical Circuit Connection of SAL-430 / 460

Please connect SAL-430 / 460 series 230V model of machines with AC 3 Φ , 230V 50Hz power supply and earth wire, and for SAL-430 / 460 series 400V model, please connect it with AC 3 Φ , 400V 50Hz power supply and earth wire.

Please make sure that the main power is shut off when you connect the machine with power supply!

5.2 Installation Space

During installation of the machine, keep at least 1m installation space around the machine as shown by the picture.

Do not install the machine in a position crowded with other objects. This would cause inconvenience to operation, maintenance and repair.

Do not sit on the machine.

Keep away flammable and explosive goods.

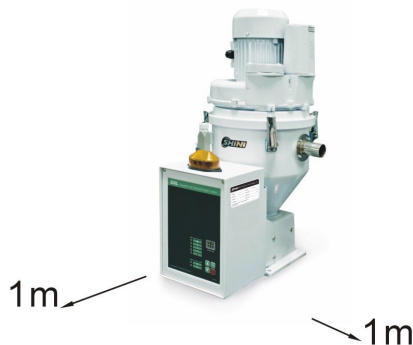

Picture 5-2: Installation Space

6. Application and Operation

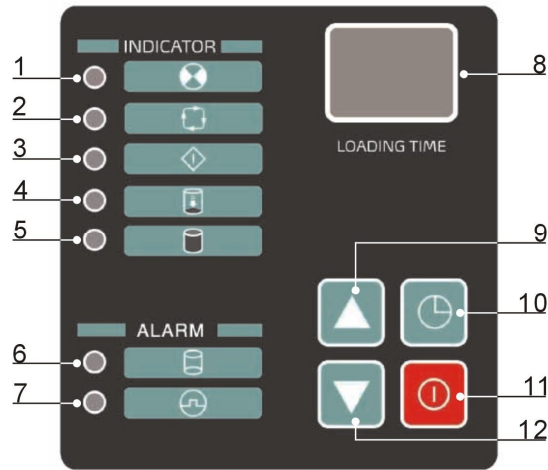

Picture 6-1: Control Panel



Table 6-1: Control Panel Description

No.	Description	Function
1	Power indicator	Machine power on
2	Operation indicator	Machine run or stop
3	Preparation indicator	Suction preparation
4	Suction indicator	Material suction
5	Full load indicator	Hopper full load
6	Shortage indicator	Material shortage
7	Overload indicator	Motor alarm
8	Increase key	Add the value
9	Time/parameter display	Display the time/parameter
10	Set key	Enter parameter setting
11	Start/stop key	Machine start/stop control
12	Decrease key	Decrease the value



6.1 Start / Stop of the Machine

The start/stop of the SAL-430 / 460 series hopper loaders are controlled by the  on the control panel.

6.2 Control Panel

1. Press  to set a proper conveying time of material. For commonly used materials, set the conveying time as 20 seconds.
2. Press  to make the machine start loading material. Press  again to stop working of the machine.



The machine will stop working and sound the alarm at the time of material shortage. Press  to switch off the machine. After adding material or fixing the problem, press  to make the machine resume working.



Please clean the filter bag periodically to keep effective suction power.

6.3 Function Setup

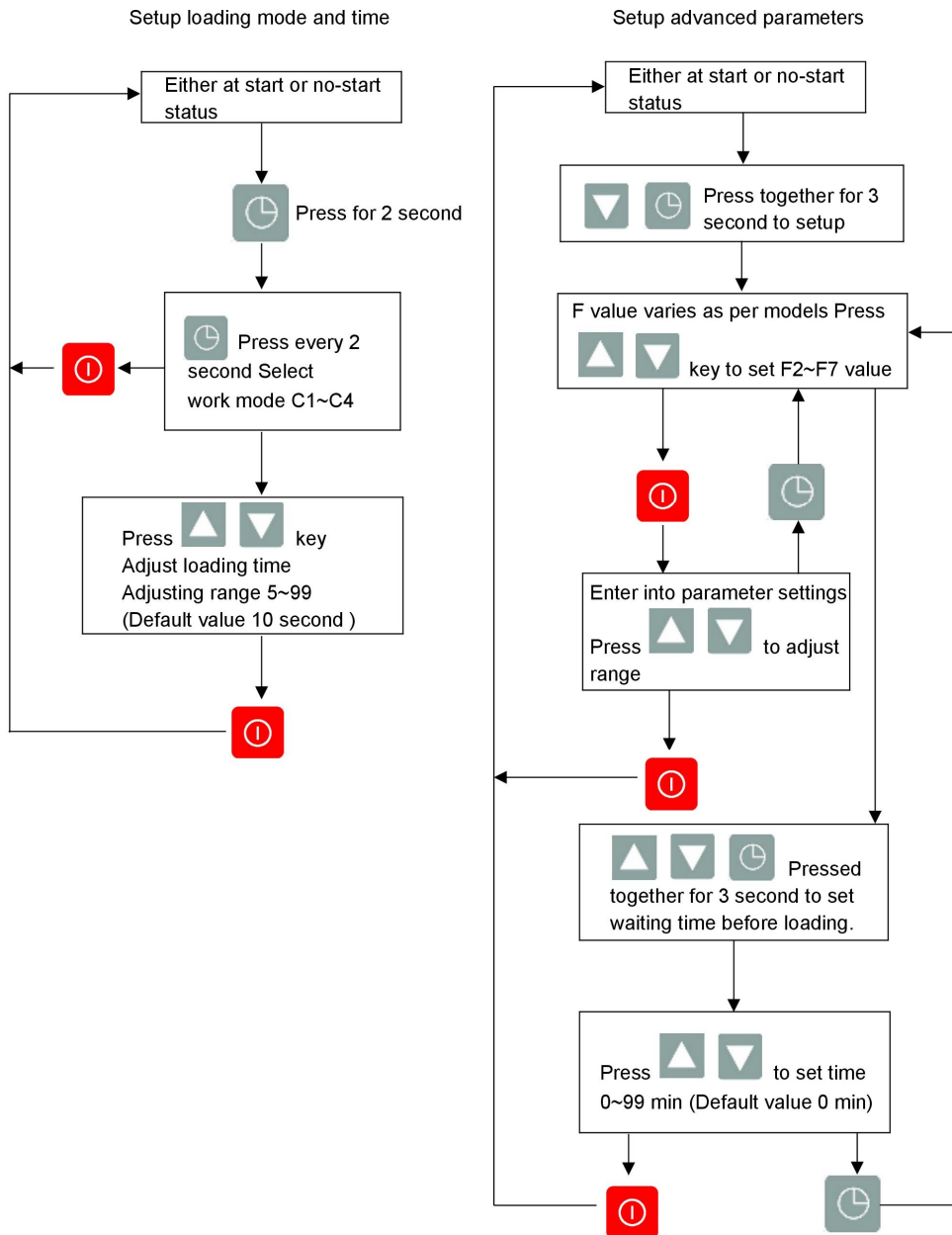
6.3.1 Setup



6.3.2 Actions

1. Press down  to switch between start / stop status.
2. Press  key to select working mode.

Mode	Meaning	Suitable model
C1	Auto loading, material shortage alarms whenever no material being loaded.	SAL-700G / 800G models
C2	After auto loading, purge as per set period and times.	SAL-330 / 360 models
C3	Motor reverse running for dust separating.	SAL-430 / 460 models
C4	Auto loading, material shortage alarms after three time no material being loaded.	SAL-700G / 800G models

3. At standby state, the seven sectional display will display loading time.
4. Action flow:

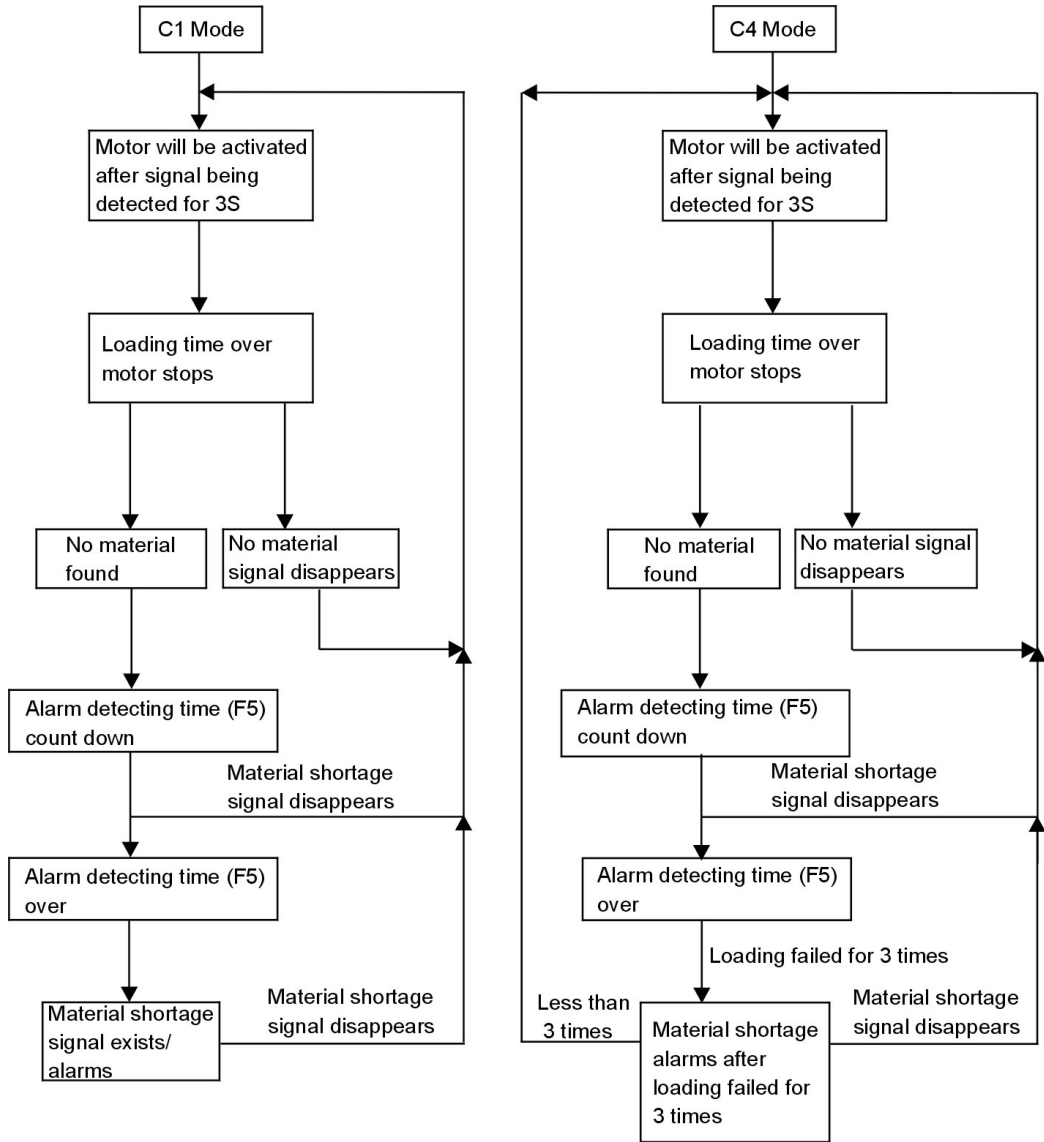

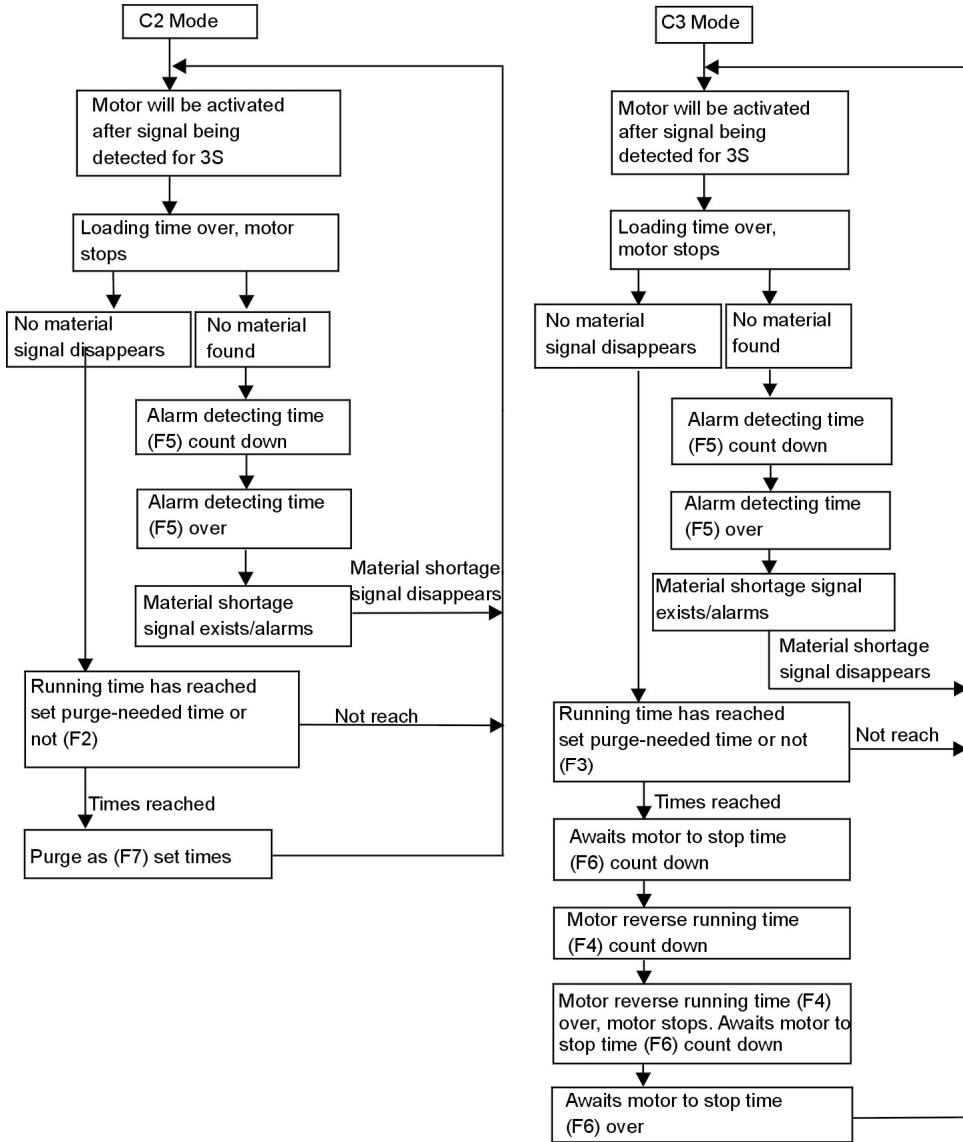

6.3.3 Parameter List

Code	Status	Default value	Adjusting range	Mode
F2	Necessary spray washing times every several times for operation	3times	1~10 times	C2
F3	Necessary cleaning times for reverse running every several times of operation	3 times	1~10 times	C3
F4	Motor reverse running time	10sec	5~30 sec	C3
F5	Alarm detecting time	20 sec	10~40 sec	C1,C2,C3,C4
F6	Awaits motor to stop time	30 sec	30~99 sec	C3
F7	Purge times	2 times	1~5 times	C2
F8	Loading latency time	0	0~99 times	C1,C2,C3,C4

6.3.4 Other Settings

1. Any setting before power on will be saved automatically and back to shut off state after 5 second of no operation.
2. Any setting after power on will be saved automatically and back to standby state after 5 second of no operation.
3. No material shortage signal is being detected even after all action is over, then if press key for 3 second, motor will perform reverse running action, when release the keys to stop motor and await the motor stop count down and back to standby state to detect material shortage signal.
4. Function of the jumper: working mode of C1, C3 and C4 will be activated when jumping out which is applicable to SAL-700G / 800G / 430 / 460. When disconnected, only working mode of C1, C2 and C4 are available which can be used for SAL-700G / 800G / 330 / 360.

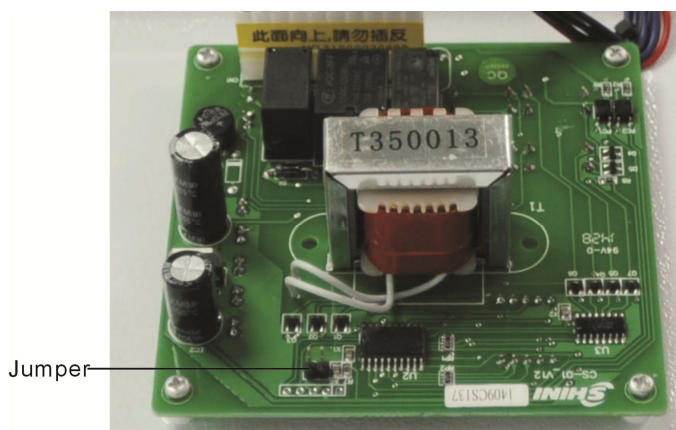

7. Trouble-shooting

7.1 Trouble Shooting for SAL-430/460 Series

Failures	Possible Causes	Solutions
Motor does not work long after material discharged.	Motor and electromagnetic contactor failure.	Repair or replace.
	Poor contact of microswitch.	Adjust or replace
	Signal wire broken.	Replace the signal wire.
Motor keep on working after loading time is running out.	Contactor malfunctions.	Repair or replace contactor
	PCB is broken	Replace
Can not full-load the material for several times or alarm indicating material shortage.	Material is used up.	Add material to storage bin.
	Leakage in conveying hose.	Lock up or replace conveying hose
	Filter is blocked.	Clear up filter screen
Motor does not work.	Short of phase or motor failures.	Repair or replace
Fuse melt after startup of the machine.	Short circuit or motor failures.	Check electrical circuit
The alarm indicating motor overload	Filter screen is blocked	After cleaning of filter screen,press Reset on the overload relay.
	Phase shortage	After fixed the circuit, press Reset on the overload relay.
Poor material liquidityin the pipe	Over or lack of air quantity	Adjust air inlet location of the suction box. Avoid small bending of the elbow.

8. Maintenance and Repair

All repair work should be done by professionals to prevent personal injuries and damages of the machine.

8.1 Filter Bag

For SAL-430/460 series, filter bag are fitted. They need to be cleaned periodically or at the time when conveying capacity of the machine decreases. Firstly, disconnect the 4P heavy-duty connector which connected the blower to control box, then loosen the snap hook of the hoop cover, take down the hopper cover, take out the filter bag. Remove all the dusts and sundries collected on the filter screen to ensure stable airflow passed through it which to improve the suction ability of the machine. For what should be paid special attention is that before taking off the blower, it must loosen the 4P heavy-duty connector firstly. When install the after cleaning, don't put your hands below the hopper cover to avoid hands nipping by the cover.

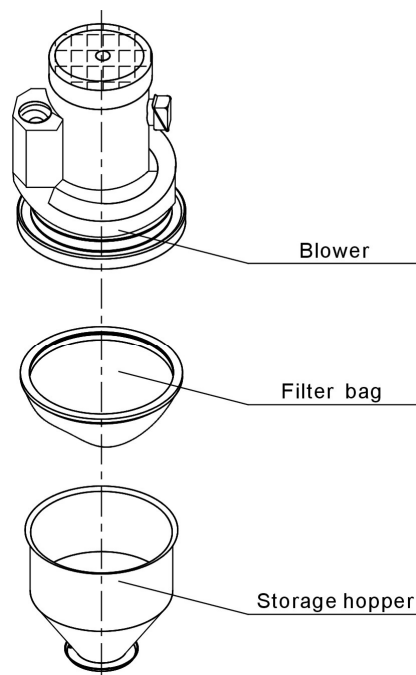

Picture 8-1: Filter Screen

- 1) Clear the blower from inside out regularly. If there are too much dirt accumulated on the blower, the function of the blower will be affected,

such as temperature rising, reduced air volume and higher noise level and vibration. All the above factors are liable to cause mechanical problems.

- 2) Check the status of blower performance. If the blower can not start or makes loud noises, repair or replace the motor.
- 3) The bearing, seal ring and silencer are consumable parts. They should be replaced after a period of time. The fans, covers, and metal screen also need to be replaced when necessary.

Note: Cut off main power when checking the electrical wire.

8.2 Storage Hopper

- 1) Loose the snap hook, and take out hopper cover.
- 2) Use high pressure air to blow away all the material remains.
- 3) Re-fix the hopper cover and fasten the snap hook.

Note: please make sure that the main switch is shut off before cleaning.

8.3 Service Life of Product Key Part

Name of the Parts	Service Life
Motor	Above 5 years
Circuit breaker	Above 100,000 act

8.4 Maintenance Schedule

8.4.1 About the Machine

Model: _____ SN: _____ Manufacturing date: _____

Voltage: _____ Φ _____ V Frequency: _____ Hz Total power: _____ kW

8.4.2 Check after Installation

- Check that the conveying hose is correctly connected.
- Check that the conveying hose is tightly connected.
- Check that the mounting base is tightly fixed.

Electrical Specifications

- Voltage: _____ V _____ Hz
- Fuse burnt current: One phase _____ A Three-phase _____ A
- Check phase sequence of power supply

8.4.3 Daily Checking

- Check main power switch
- Check filter screen
- Check motor performance

8.4.4 Weekly Checking

- Check if there are damaged electrical wires
- Check if there are loose connections of electrical components
- Check if the screws of flange at material inlet are loose or not

8.4.5 Monthly Check

- Check the spring lock on the hopper cover is loosed or not.
- Check the non-return valve is deformed or not.
- Check the performance of magnetic proximity switch/photoelectrical sensor.