

**SCD Series**  
**"All-in-One" Compact Dryer**

Date: Dec. 2018

Version: Ver.F (English)





## Contents

<b>1. General Description .....</b>	<b>7</b>
1.1 Coding Principle .....	8
1.2 Features .....	8
1.3 Technical Specifications.....	10
1.3.1 Drying Capacity .....	13
1.4 Safety Regulations .....	15
1.4.1 Safety Regulations for the Blowers.....	15
1.4.2 Safety Signs and Labels.....	16
1.4.3 Transportation and Storage of the Machine.....	16
1.5 Exemption Clause .....	18
<b>2. Structure Characteristics and Working Principle .....</b>	<b>19</b>
2.1 Working Principle .....	19
2.2 Relative Humidity and Dew-point .....	20
2.3 Why Choose "All-in-One" Compact Dryer .....	20
2.4 Options.....	21
<b>3. Installation Testing.....</b>	<b>23</b>
3.1 Machine Location .....	23
3.2 Air Pipe and Material Pipe Connection.....	24
3.3 Cooling Water Connection .....	25
3.3.1 Cooling Water Connection.....	25
3.3.2 Condensation Drainage Pipe.....	26
3.4 Power Connection.....	26
3.5 Compressed Air Supply .....	27
3.6 Option Installation .....	27
3.6.1 Installation Steps of Cyclone Dust Collector.....	27
3.6.2 Installation Steps of Oil Filter.....	28
3.6.3 Material storage bin (MST-80U-OP).....	29
<b>4. Application and Operation.....</b>	<b>30</b>
4.1 Operation Procedure for HMI .....	30
4.1.1 Description of touch screen .....	30
4.1.2 Touch panel appear error .....	30
4.1.3 Screen operation flow Table .....	31
4.1.4 Menu Particular .....	31

4.1.4.1	System Default Screen .....	31
4.1.4.2	Drying Monitoring.....	32
4.1.4.3	Conveying Monitoring (only suitable for SCD model).....	33
4.1.4.4	Parameters Setting .....	33
4.1.4.5	Alarms Fault Records.....	38
4.1.4.6	Help Screen .....	41
<b>5.</b>	<b>Trouble-shooting .....</b>	<b>42</b>
<b>6.</b>	<b>Maintenance and Repair .....</b>	<b>43</b>
6.1	Filter & Pressure Regulating Valve .....	44
6.1.1	Filter & Pressure Regulating Valve Drawing.....	44
6.1.2	Filter & Pressure Regulating Valve Operation steps.....	44
6.2	Air Filters .....	44
6.3	Blower Motors .....	45
6.3.1	Drying Blower .....	45
6.3.2	Regeneration Blower .....	45
6.3.3	Conveying Blower.....	45
6.3.4	Blower Cleaning .....	46
6.4	The Service Life of the Key Parts of the Product.....	46
6.5	Honeycomb-rotor .....	47
6.5.1	What is Honeycomb-rotor.....	47
6.5.2	Installation Steps of the Rotor.....	47
6.6	EGO .....	49
6.7	Cooler .....	49
6.8	Maintenance Schedule.....	51
6.8.1	General Machine Information .....	51
6.8.2	Installation & Inspection.....	51
6.8.3	Daily Checking.....	51
6.8.4	Weekly Checking.....	51
6.8.5	Monthly Checking .....	52
6.8.6	Half-yearly Checking .....	52
6.8.7	Yearly Checking .....	52
6.8.8	3 year Checking.....	52

Table 1-1: Specifications 1(Hermetic Design).....	10
Table 1-2: Specifications 2 (Hermetic Design).....	11
Table 1-3: Specifications (Semi-open Design).....	12
Table 1-4: Drying Capacity 1 .....	13
Table 1-5: Drying Capacity 2 .....	14
Table 4-1: Touch panel information .....	30
Table 4-2: Adjustment of proportion (P).....	35
Table 4-3: Adjustment of integral time (I).....	35
Table 4-4: Adjustment of differential time (D) .....	36
Table 4-5: Alarm Information List.....	40
Table 6-1: Filter & Pressure Regulating Valve Assembly .....	44
Table 6-2: The Service Life of the Key Parts of the Product .....	46

### Picture Index

Picture 1-1: Technical Specifications .....	10
Picture 1-2: Blower .....	15
Picture 2-1: SCD Working Principle .....	19
Picture 2-2: SCD-OP Working Principle (With plate Heat Exchanger) (Option) .....	19
Picture 3-1: Installation Drawing .....	23
Picture 3-2: Schematic Drawing of Installation (Hermetic Design).....	24
Picture 3-3: Schematic Drawing of Installation (Semi-integral Design) .....	24
Picture 3-4: Cooling Water Connection.....	25
Picture 3-5: Installation Diagram of Cyclone Dust Collector .....	28
Picture 3-6: Installation Diagram of Oil Filter .....	28
Picture 3-7: Material Stage Bin of Optical Grade MST-80U-OP .....	29
Picture 4-1: Description of touch screen .....	30
Picture 4-2: Screen operation flow table .....	31
Picture 4-3: System initial screen.....	31
Picture 4-4: Drying process screen.....	32
Picture 4-5: Conveying process screen .....	33
Picture 4-6: Password input screen .....	33
Picture 4-7: Parameters setting .....	34
Picture 4-8: Temperature parameters setting 1 .....	34

Picture 4-9: Temperature parameters setting 2 .....	34
Picture 4-10: Temperature parameters setting 3 .....	35
Picture 4-11: Conveying parameter setting.....	36
Picture 4-12: Rotor parameter screen.....	37
Picture 4-13: Time setting.....	38
Picture 4-14: PLC time setting .....	38
Picture 4-15: Alarm fault records .....	39
Picture 4-16: Help Screen.....	41
Picture 6-1: Filter & Pressure Regulating Valve Drawing.....	44
Picture 6-2: Filter Cleaning .....	45
Picture 6-3: Installation of Blowers.....	45
Picture 6-4: Conveying Blower .....	46
Picture 6-5: Blower .....	46
Picture 6-6: Honeycomb Rotor .....	47
Picture 6-7: Rotor Installation Diagram .....	48
Picture 6-8: EGO .....	49

# 1. General Description



Read this manual carefully before operation to prevent machine damage or personal injuries.

SCD Compact Dryer has three functions of dehumidification, drying and two-stage conveying, which is especially suitable for processing engineering plastics materials with high hygroscopicity, such as PA, PC, PBT, PET. The optical SCD-OP can be used for lens, LCD backlight board and discs productions that reaches the dew-point below  $-40^{\circ}\text{C}$  under ideal condition.



SCD-600U/400H-LC-D

## 1.1 Coding Principle

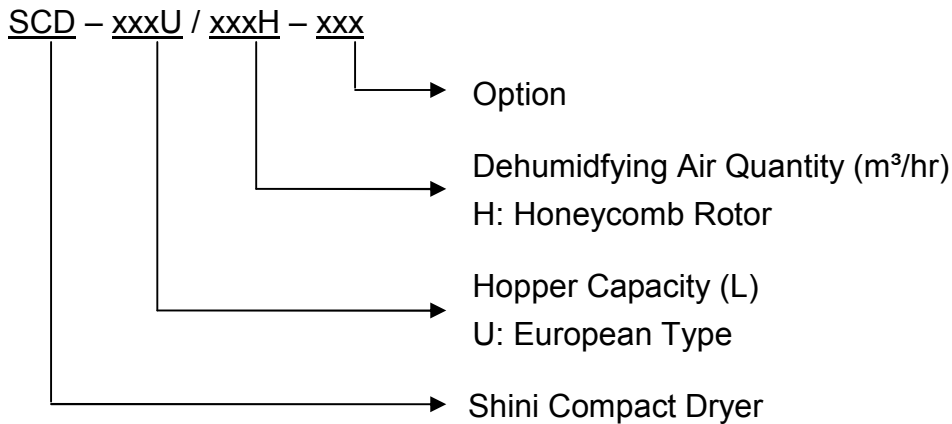

## 1.2 Features

- Combine the function of dehumidifying, drying and two-stage conveying into a single unit.
- SCD Dryer Loaders are equipped with honeycomb rotor to obtain stable low dew-point drying air, which have two models: semi-open and hermetic.
- Feeding system is equipped with shut-off valve to ensure no residuals in hopper tubes.
- Microprocessor is standard equipped for the control.
- Heat-preserved drying hopper adopts down-blow pipe design that collocates with cyclone air exhaust to avoid heat lost and improve drying efficiency.

All machine service should be performed by professional technicians. This manual is applicable to the operator and maintenance personnel on the field. The service instruction of Chapter 6 is intended for service engineers, and other chapters are for the operator.

Any modifications of the machine must be approved by SHINI in order to avoid personal injury and machine damage. We shall not be liable for any damage caused by unauthorized change of the machine.

Our company provides excellent after-sales service. If there's any problem during the application, please contact the company or local vendor.



Headquarter and Taipei factory:

Tel: (886) 2 2680 9119

Shini Plastics Technologies (Dongguan), Inc:

Tel: (86) 769 8111 6600

Shini Plastics Technologies India Pvt.Ltd.:

Tel: (91) 250 3021 166

## 1.3 Technical Specifications

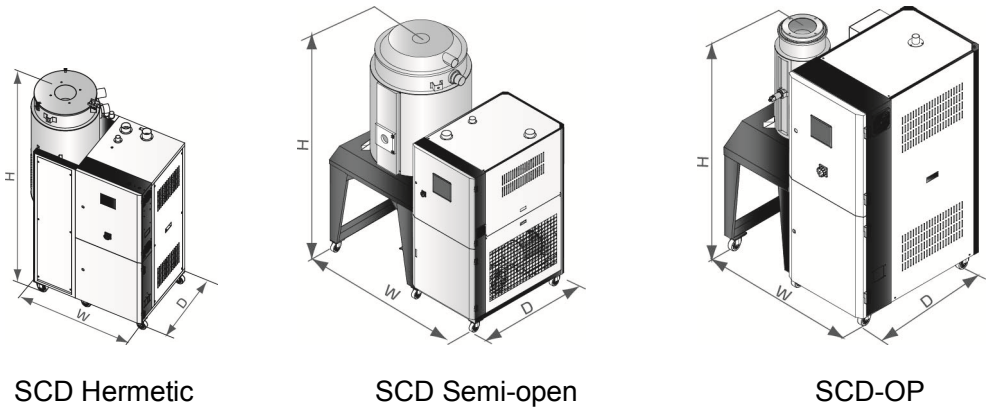

Picture 1-1: Technical Specifications

Table 1-1: Specifications 1(Hermetic Design)

Model SCD-	20U/30H-OP	40U/30H-OP	80U/50H-OP	120U/80H-OP
Version	D	D	D	D
Drying System				
Drying Heater Power (kW)	3	3	3.9	6
Drying Blower Power (kW)	0.4	0.4	0.4	0.75
Hopper Capacity (L)	20	40	80	120
Dehumidifying System				
Regenerating Heater Power (kW)	3	3	3	3
Regenerating Blower Power (kW)	0.4	0.4	0.4	0.4
Dehumidifying Air quantity (m <sup>3</sup> /hr)	30	30	50	80
Feeding System				
Feeding Blower Power (kW)	1.5	1.5	1.5	1.5
Dia. of Material Pipe (inch)	1.5	1.5	1.5	1.5
SHR-U-E Hopper (L)	3*	3*	3*	3*
SHR-U Hopper (L)	3	3	6	6
Dimensions				
H(mm)	1400	1500	1670	1710
W(mm)	1050	1050	1240	1240
D(mm)	900	900	1000	1000
Weight (kg)	235	280	330	385

Note: 1) Plastic materials can be completely dried by drying air with dew-point temperature  $\leq -20^{\circ}\text{C}$ . When the ambient temperature  $\leq -25^{\circ}\text{C}$ , and relative humidity  $\leq 60\%$ , the drying air dew-point temp.  $\leq -40^{\circ}\text{C}$ .

2) "\*" stands for hopper receiver SHR-CP-U.

3) Power supply: 3 $\Phi$ , 230 / 400 / 460 / 575VAC, 50 / 60Hz.

We reserve the right to change specifications without prior notice.

Table 1-2: Specifications 2 (Hermetic Design)

Model SCD-	40U /40H	80U /40H	120U /80H	160U /80H	160U /120H	230U /120H	300U /200H	450U /200H
Version	D	D	E	E	E	D	D	D
Drying System								
Drying Heater Power (kW)	4	4	4	4	6	6	12	12
Drying Blower Power (kW)	0.12	0.12	0.75	0.75	0.75	0.75	1.5	1.5
Hopper Capacity (L)	40	80	120	160	160	230	300	450
Dehumidifying System								
Regenerating Heater Power (kW)	3	3	3	3	4	4	4	4
Regenerating Blower Power (kW)	0.12	0.12	0.4	0.4	0.4	0.4	0.4	0.4
Dehumidifying Air quantity (m <sup>3</sup> /hr)	40	40	80	80	120	120	200	200
Feeding System								
Feeding Blower Power (kW)	1.5	1.5	1.5	1.5	1.5	1.5	1.5	1.5
Dia. of Material Pipe (inch)	1.5	1.5	1.5	1.5	1.5	1.5	1.5	1.5
SHR-U-E Hopper (L)	3	6	6	6	6	12	12	12
SHR-U Hopper (L)	3	6	6	6	6	12	12	12
Dimensions								
H(mm)	1672	1751	1957	2102	2102	2012	2160	2350
W(mm)	1051	1066	1125	1125	1125	1223	1460	1460
D(mm)	734	734	734	734	734	134	1020	1020
Weight (kg)	295	325	340	350	390	420	565	595

Note: 1) Plastic materials can be completely dried by drying air with dew-point temperature  $\leq 20^{\circ}\text{C}$ . When the ambient temperature  $\leq 25^{\circ}\text{C}$ , and relative humidity  $\leq 60\%$ , the drying air dew-point temp.  $\leq 40^{\circ}\text{C}$ .

2) "\*" stands for hopper receiver SHR-CP-U.

3) Power supply: 3 $\Phi$ , 230 / 400 / 460 / 575VAC, 50 / 60Hz.

We reserve the right to change specifications without prior notice.

Table 1-3: Specifications (Semi-open Design)

Model SCD-	600U/400H	750U/400H	900U/700H	1200U/700H
Version	C	C	F	F
Drying System				
Drying Heater Power (kW)	18	18	24	24
Drying Blower Power (kW, 50/60Hz)	3.75 / 4.5	3.75 / 4.5	7.5 / 8.6	7.5 / 8.6
Hopper Capacity (L)	600	750	900	1200
Dehumidifying System				
Regenerating Heater Power (kW)	7.2	7.2	10	10
Regenerating Blower Power (kW, 50/60Hz)	0.75 / 0.9	0.75 / 0.9	1.5 / 1.8	1.5 / 1.8
Dehumidifying Air quantity (m <sup>3</sup> /hr, 50/60Hz)	400 / 450	400 / 450	700 / 780	700 / 780
Feeding System				
Feeding Blower Power (kW)	1.5	1.5	3.75	3.75
Dia. of Material Pipe (inch)	1.5	1.5	2	2
SHR-U-E Hopper Receiver (L)	12	12	24	24
SHR-U Hopper Receiver (L)	12	12	24	24
Dimensions				
H(mm)	2380	2610	2640	3070
W(mm)	1745	1745	2140	2140
D(mm)	1255	1255	1380	1380
Weight (kg)	640	690	850	900

Note: 1) Plastic materials can be completely dried by drying air with dew-point temp.  $\leq -20^{\circ}\text{C}$ . When ambient temperature  $\leq -25^{\circ}\text{C}$ , and relative humidity  $\leq 60\%$ , the drying air dew-point temp.  $\leq -40^{\circ}\text{C}$ .

2) "\*" stands for hopper receiver SHR-CP-U.

3) Power supply: 3 $\Phi$ , 230 / 400 / 460 / 575VAC, 50 / 60Hz.

We reserve the right to change specifications without prior notice.

### 1.3.1 Drying Capacity

Table 1-4: Drying Capacity 1

Material	Drying Temp. (°C)	Drying Time (hr)	Drying Capacity (kg/hr)						
			40U /40H	80U /40H	120U /80H	160U /80H	160U /120H	230U /120H	300U /200H
ABS	80	2-3	16		27		35		105
CA	75	2-3	12		22		30		90
CAB	75	2-3	12		22		30		90
CP	75	2-3	16		27		35		106
LCP	150	4	11		20		27		80
POM	100	2	24		40		53		160
PMMA	80	3	17		29		38		115
IONOMER	90	3-4	10		17		22		66
PA6/6.6/6.10	75	4-6	9		14		19		58
PA11	75	4-5	10		17		23		69
PA12	75	4-5	10		17		23		69
PC	120	2-3	19		31		41		124
PU	90	2-3	17		29		38		115
PBT	130	3-4	13		23		31		93
PE	90	1	47		80		106		318
PEI	150	3-4	11		20		27		80
PET	160	4-6	11		19		25		75
PETG	70	3-4	11		20		27		80
PEN	170	5	13		23		30		90
PES	150	4	13		23		30		90
PMMA	80	3	17		29		28		115
PPO	110	1-2	19		33		44		133
PPS	150	3-4	11		20		27		80
PI	120	2	24		40		53		160
PP	90	1	39		66		88		265
PS(GP)	80	1	39		66		88		265
PSU	120	3-4	12		22		29		85
PVC	70	1-2	19		33		44		135
SAN(AS)	80	1-2	19		33		44		135
TPE	110	3	18		30		40		125

Note: 1) Please refer to above drying capacity of the SCD, and select right model based on material dosage and drying capacity.  
 2) Please consult Shini service staff for model selection.

Table 1-5: Drying Capacity 2

Material	Drying Temp. (°C)	Drying Time(hr)	Drying Capacity (kg/hr)			
			600U /400H	750U /400H	900U /700H	1200U /700H
ABS	80	2-3	210		355	
CA	75	2-3	180		295	
CAB	75	2-3	180		295	
CP	75	2-3	210		355	
LCP	150	4	160		365	
POM	100	2	320		530	
PMMA	80	3	230		383	
IONOMER	90	3-4	133		220	
PA6/6.6/6.10	75	4-6	115		192	
PA11	75	4-5	138		230	
PA12	75	4-5	138		230	
PC	120	2-3	250		413	
PU	90	2-3	230		383	
PBT	130	3-4	186		310	
PE	90	1	637		1062	
PEI	150	3-4	160		265	
PET	160	4-6	150		250	
PETG	70	3-4	160		265	
PEN	170	5	180		300	
PES	150	4	180		300	
PMMA	80	3	230		385	
PPO	110	1-2	265		440	
PPS	150	3-4	160		265	
PI	120	2	320		530	
PP	90	1	530		885	
PS(GP)	80	1	531		885	
PSU	120	3-4	173		290	
PVC	70	1-2	265		442	
SAN(AS)	80	1-2	265		442	
TPE	110	3	250		413	

Note: 1) Please refer to above drying capacity and material dosage to select the right model of the SCD.  
 2) Please consult Shini service staff for model selection.

## 1.4 Safety Regulations

### 1.4.1 Safety Regulations for the Blowers

- 1) Under normal operation, the blowers will generate high temperature. Do not touch blower's case to avoid any physical injury.
- 2) Under normal operation, the current loading of blower motor will increase or reduce according to air pressure's change accordingly. During the wiring, adequate motor overload protection switch should be installed with full loading test, to ensure operating safely under full-loading and avoid motor damage.
- 3) As to avoid any block materials, dust, powder, fiber particles and water drops entering the blower that cause the deficiency of its performance. This machine is designed with air filter, clean up the foreign particles in the filter (recommended to clean up this filter weekly).
- 4) Clean the internal and external parts (especially for the fan cooling path) of the blower, and remove the dust on surface if necessary. If more dusts are accumulated, it will cause ventilation deficiency, temperature rising, vacuum power reduce, vibration increase that cause machine broke down.
- 5) Ball bearing, oil seal and soundproof are the consumable parts that have life period and equire regular replacement. Meanwhile, blade, external case, and metallic screen should be replaced regularly for best performance.
- 6) Under normal operation, if the blowers are not running smoothly or abnormal noise appeared. Please immediately shut down the machine for repair.



Picture 1-2: Blower

## 1.4.2 Safety Signs and Labels



Danger!

High voltage danger!

This label is stuck on the electrical boxes.



Attention!

This label means that this area should be taken care!



Warning!

High temperature, take care of hands!

This label should be stick to the shell of heater.



Attention!

No need for regular inspection because all the electrical parts in the control unit are fixed tightly!



Note!

The EGO over-temperature protection is only for process heater protection, not for material protection usage, and the default setting should not be changed.

## 1.4.3 Transportation and Storage of the Machine

### Transportation

- 1) SCD series "All-in-one" compact dryer are packed in crates or plywood cases with wooden pallet at the bottom, suitable for quick positioning by fork lift.
- 2) After unpacked, castors equipped on the machine can be used for ease of movement.
- 3) Don't rotate the machine and avoid collision with other objects during transportation to prevent improper functioning.
- 4) The structure of the machine is well-balanced, although it should also be handled with care when lifting the machine for fear of falling down.



- 5) The machine and its attached parts can be kept at a temperature from  $-25^{\circ}\text{C}$  to  $+55^{\circ}\text{C}$  for long distance transportation and for a short distance, it can be transported with temperature under  $+70^{\circ}\text{C}$ .

#### Storage:

- 1) SCD series "All-in-One" compact dryer should be stored indoors with temperature kept from  $5^{\circ}\text{C}$  to  $40^{\circ}\text{C}$  and humidity below 80%.
- 2) Disconnect all power supply and turn off main switch and control switch.
- 3) Keep the whole machine, especially the electrical components away from water to avoid potential troubles caused by the water.
- 4) Plastic film should be used to protect the machine from dust and rains.

#### Working environment:

- 1) Indoor, in dry environment with max. temperature  $+45^{\circ}\text{C}$  and humidity no more than 80%.

#### Do not use the machine:

- 1) If it is with a damaged cord.
- 2) On a wet floor or when it is exposed to rain to avoid electrical shock.
- 3) If it has been dropped or damaged until it is checked or fixed by a qualified serviceman.
- 4) This equipment works normally in the environment with altitude within 3000m.
- 5) At least a clearance of 1m surrounding the equipment is required during operation. Keep this equipment away from flammable sources at least two meters.
- 6) Avoid vibration, magnetic disturbance at the operation area.

#### Rejected parts disposal

When the equipment has run out its life time and can not be used any more, unplug the power supply and dispose of it properly according to local code.

#### Fire hazard.



In case of fire, CO<sub>2</sub> dry powder fire extinguisher should be applied.

## 1.5 Exemption Clause

The following statements clarify the responsibilities and regulations born by any buyer or user who purchases products and accessories from Shini (including employees and agents).

Shini is exempted from liability for any costs, fees, claims and losses caused by reasons below:

- 1) Any careless or man-made installations, operation and maintenances upon machines without referring to the Manual prior to machine using.
- 2) Any incidents beyond human reasonable controls, which include man-made vicious or deliberate damages or abnormal power, and machine faults caused by irresistible natural disasters including fire, flood, storm and earthquake.
- 3) Any operational actions that are not authorized by Shini upon machine, including adding or replacing accessories, dismantling, delivering or repairing.
- 4) Employing consumables or oil media that are not appointed by Shini.

## 2. Structure Characteristics and Working Principle

### 2.1 Working Principle

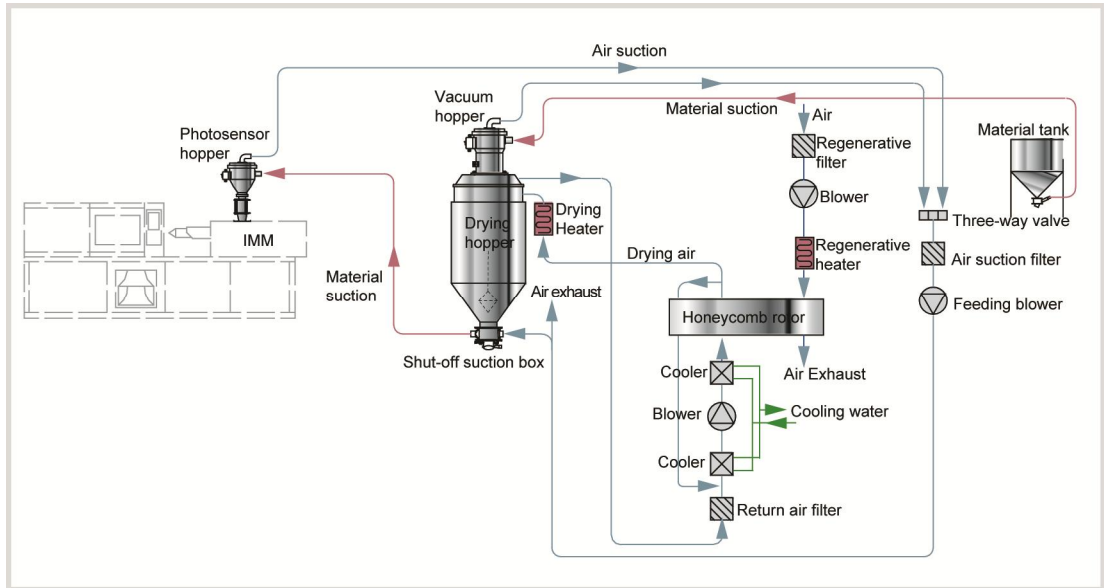

Picture 2-1: SCD Working Principle

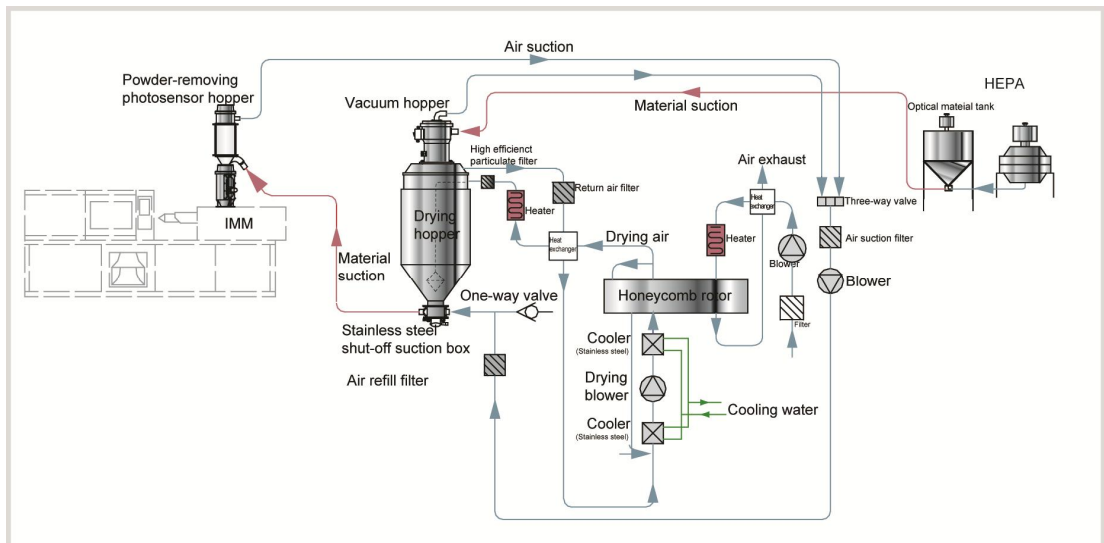

Picture 2-2: SCD-OP Working Principle (With plate Heat Exchanger) (Option)

Dehumidifying: damp and hot air from dry material barrel is blown into rotor after cooled. Moisture from the air is absorbed by rotor and is then adsorbed by

regeneration heating air. Two strands of airflow function on the rotor. And with the rotation, moisture from the air is absorbed and expelled after absorbed regeneration air to form stable low dew-point air, which is dried to the drying temperature and then is blown into material barrel to closed circle to dry material.

Suction: material is absorbed into barrel from storage barrel or other storage containers. When the magnetic reed switch detects no material, suction motor runs to produce vacuum inside vacuum hopper. Raw material in storage barrels is absorbed into suction hopper due to air pressure difference. When the time is completed, suction motor stops. Raw materials drop into drying hopper barrel due to gravity. The dried raw material after drying is taken out to the hopper by photosensor installed on molding machine or other hopper form drying hopper barrel.

## 2.2 Relative Humidity and Dew-point

Relative humidity: Relative air humidity means real vapor content to saturated vapor at the same temperature in percentage. Dew point: it means that temperature when the saturation vapor begins to dew. When the relative humidity is 100%, the ambient temperature is the dew point temperature. The lower of dew point temperature (than the ambient temperature) is, the less possible to dew, that also means the more drier the air is. The dew point will not be influenced by temperature, but influenced by pressure.

## 2.3 Why Choose "All-in-One" Compact Dryer

For these quality deficiencies as bubble, crazing, cracking, poor transparency are due to insufficient drying of plastic materials before molding, and the engineering plastics such as: PC, PA, PBT, PET, Nylon, etc. The hygroscopic materials used in the plastics industry such as PC, PA, PBT, PET, Nylon, etc. cannot be dried effectively by conventional hot air drying systems because the moisture enters inside the particles. According to suggestion of the manufacturer, the plastic materials can be completely dried by drying air with dew-point temperature  $\leq -20^{\circ}\text{C}$ . However, the SCD sufficiently dehumidifies and dries the air inside the closed-loop system, and the dry air eliminates the moisture fast and completely as to reach the drying and dehumidifying effect.

## 2.4 Options

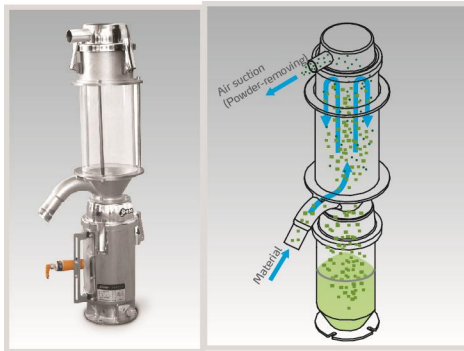

Optical Powder-removing Hopper



SCD-OP High-efficiency Filter

- Optical SCD-OP series equipped with powder-removing hopper which can avoid powders in production; material contact surfaces are stainless-steel polished that collocate conveying system with closed loop to avoid contamination and moisture regain; system has standard configuration of high-efficiency filter, which can filter tiny ion of  $0.3\mu\text{m}$  with filter ratio of 99.995%. (Only Apply to SCD-20U/30H~SCD-120U/80H)



High-efficiency Filter HEPA ( $0.3\mu\text{m}$ )



Optical Material Tank ( $5\mu\text{m}$ )

- Available to option with human-machine interface (LCD control with HMI), and add "LC" at the end of the model code.
- Built-in type, which means that dew-point monitor is installed on the machine, is convenient to monitor dew-point temperature. Add "D" at the end of the model code.
- Portable type, which means that dew-point monitor is separate from the machine, is convenient to test dew-point temperature of different machines. Add "PD" at the end of the model code.

- Optical-class models can select high-efficient filter (left) and optical-class storage hopper (right) to avoid material contamination in the conveying process.
- Built-in type, which means that dew-point monitor is installed on the machine, is convenient to monitor dew-point temperature. Add "D" at the end of the model code.



Dew-point Monitor (portable)

- For models with energy-saving drying management, add "ES" at model behind, and standard equipped with HMI touch control, which can save up to 41% of total power consumption. Volume used per hour is settable between 40~100% as drying capacity to save the total power consumption of 35%~0; Standard equipped with heat regenerative recycler which recycles the regeneration air exhausted heat via plate heat exchanger and can save 3%~6% of total power consumption.
- For models optional with drying heat recycler, add "HE" at model behind. Dehumidified low temperature air via plate heat exchanger to recycle the heat of hot-wet return air, which can higher the air temperature in drying heater and lower the power consumption of the heater, the total power consumption can save 0%~19%.
- Three-stage conveying function is available to feed two sets of injection molding machines. Add "M2" at the end of the model code.
- Three-stage conveying function is available to feed two sets of injection molding machines. Add "M2" at the end of the model code.
- Polished surface inside of hopper, Plus "P" at the end of the model code.

### 3. Installation Testing

This series of models only could be applied in working environment with good ventilation.

#### 3.1 Machine Location



Picture 3-1: Installation Drawing

#### Installation Notice:

- 1) The machine can only be installed in vertical position, make sure there's no pipeline, fixed structure and other object that may obstruct machine installation or cause item damage, human injuries above the selected location and adjacent areas.
- 2) For easy maintenance, leaving 1m space around machine is suggested.

***Important: Keep machine 2m away from the inflammable materials.***

- 3) The machine must be placed on the ground level to ensure balance state, and to remove the accumulated condensing water. If machine is need to install on a higher level (scaffolding or interlayer), it should make sure that the structure and size could withstand the machine.

### 3.2 Air Pipe and Material Pipe Connection

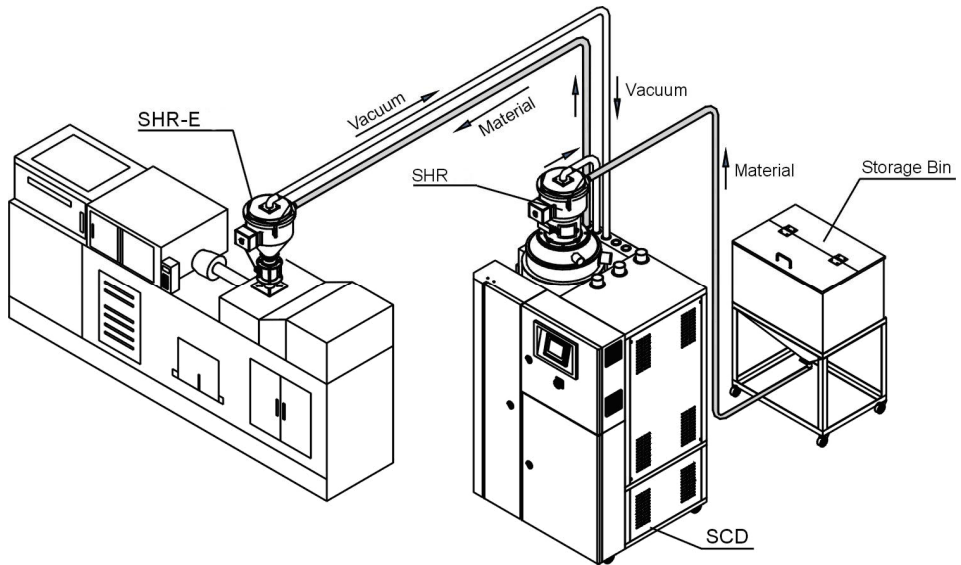

Picture 3-2: Schematic Drawing of Installation (Hermetic Design)

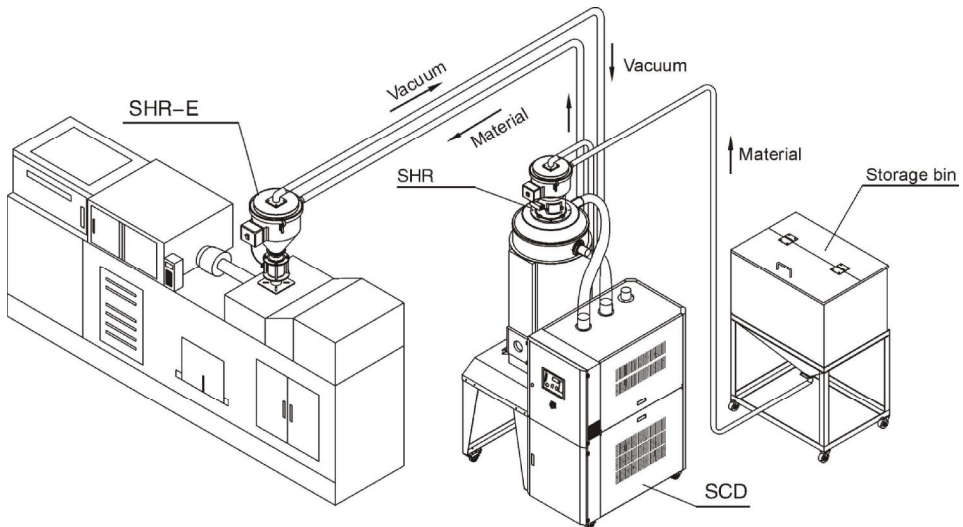

Picture 3-3: Schematic Drawing of Installation (Semi-integral Design)



### 3.3 Cooling Water Connection

Table 3-1: Cooling water connection table

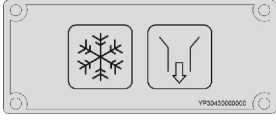
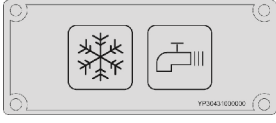
	Cooling water outlet
	Cooling water inlet

Cooling water needs to be connected the before operation. The water port is at the back of the machine.

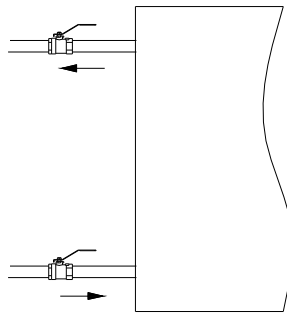

Picture 3-4: Cooling Water Connection

#### 3.3.1 Cooling Water Connection

Connect through the cooling water before machine operation. For the efficiency, please follow below suggestions:

- 1) For easy maintenance and safety, install the ball valve at cooling water inlet and outlet.
- 2) Water pipe diameter should not less than the diameter of cooling water inlet and outlet.
- 3) For water quality, it needs to sediment or filter the water before it gets into the pipe, to prevent the deposits accumulated on pipeline of cooler and performance degradation.

Table 3-2: Cooling Water Specifications

Cooling Water Specifications							
Temperature Difference between Water Inlet and Outlet		Cooling Water Pressure		Cooling Water Temperature			
5°C		3~5kgf/cm <sup>2</sup>		10~30°C			
Suggested cooling water flow rate and pipe diameter:							
Model	Flowrate of Cooling Water (L/min)	Interface specification		Model	Flowrate of Cooling Water (L/min)	Interface specification	
		Inlet	Outlet			Inlet	Outlet
30H	4	Ø23	Ø23	700H	80	Ø25	Ø25
40H	5	Ø23	Ø23	1000H	120	R <sub>2</sub> 1.5"	R <sub>2</sub> 1.5"
50H	6	Ø23	Ø23	1500H	180	R <sub>2</sub> 2"	R <sub>2</sub> 2"
120H	15	Ø23	Ø23	2000H	240	R <sub>2</sub> 2"	R <sub>2</sub> 2"
200H	30	Ø23	Ø23	3000H	360	R <sub>2</sub> 2"	R <sub>2</sub> 2"
400H	50	Ø23	Ø23	4000H	480	2X R <sub>2</sub> 2"	2X R <sub>2</sub> 2"

### 3.3.2 Condensation Drainage Pipe

During normal operation, it will generate condensation water. Connect the water pipe at drainage outlet to remove the condensation water is necessary. As to ensure high machine efficiency, following suggestions must be observed:

- 1) Drainage pipe inner diameter should not less than the diameter of drainage outlet.
- 2) Drainage pipe should be long enough to approach the drainage channel, and be the hose. Be careful not to press or bend the pipe for smooth water flow (Use the rigid pipe if there's need to press or bend the hose).
- 3) As condensation water drainage is in terms of gravity, make sure the drainage outlet is above the pipe. Otherwise the water can't be drained out and will flow back to the machine.

**Note: The size of discharging port for all models is Rc1/2" .**

### 3.4 Power Connection

- 1) Make sure the voltage and frequency of the power source comply with those indicated on the manufacturer nameplate that attached to the machine.
- 2) Power cable and earth connection should conform to your local regulations.
- 3) Use independent electrical wires and power switch. Diameter of electrical wire should not be less than those used in the control box.

- 4) The power cable connection terminals should be tightened securely.
- 5) The machine requires 3-phase 4-wire power source, connect the power lead (L1, L2, L3) to the live wires, and the earth (PE) to the ground.
- 6) Power supply requirements:  
 Main power voltage: +/- 5%  
 Main power frequency: +/- 2%
- 7) ***Please refer to electrical drawing of each model to get the detailed power supply specifications***

### 3.5 Compressed Air Supply

Table 3-4 Compressed Air Specification

Items	Value	Remark
Quality Grade	335	Solid particle content $\leq 5\text{mg/m}^3$ , dew-point temperature $< -20^\circ\text{C}$ , oil content $\leq 25\text{mg/m}^3$ , oil content $\leq 25\text{mg/m}^3$ . (Chinese standard: GB/T 13277-1991)
Air pressure (bar)	3~5bar	
Air quantity (L/hr)	~10L/hr	
Pipe dimension	PM20	Quick coupler(Chinese standard)

### 3.6 Option Installation

#### 3.6.1 Installation Steps of Cyclone Dust Collector

- 1) Connect 1 and 5 with a heat-resistant duct and fixed both the ends with stainless steel tubes.
- 2) Connect 2 and 3 with a heat-resistant duct and fixed both the ends with stainless steel tubes.
- 3) Connect 4 and 6 with a heat-resistant duct and fixed both the ends with stainless steel tubes.

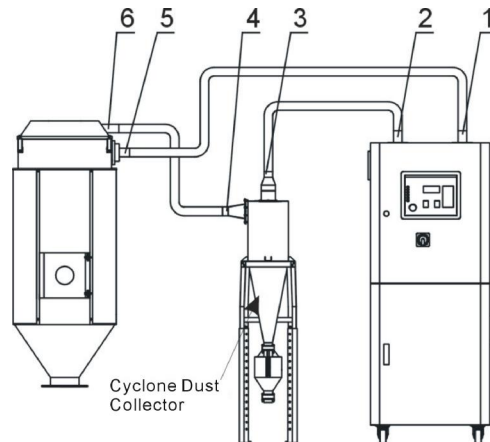

Picture 3-5: Installation Diagram of Cyclone Dust Collector

### 3.6.2 Installation Steps of Oil Filter

Oil Filter Installation Steps:

- 1) Screw the oil filter on the top plate of the honeycomb dehumidifier.
- 2) Connect 1 and 2 with a heat-resistant duct and fixed both the ends with stainless steel tubes.
- 3) Connect 3 and 4 with a heat-resistant duct and fixed both the ends with stainless steel tubes.
- 4) Connect 5 and 6 with a heat-resistant duct and fixed both the ends with stainless steel tubes.

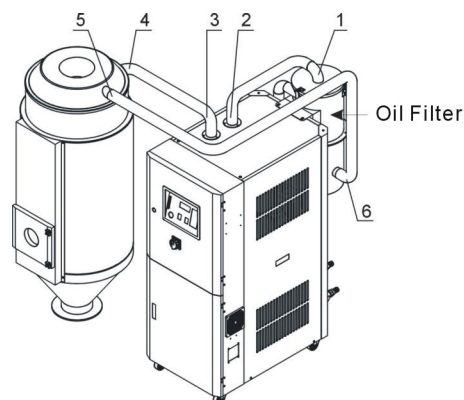

Picture 3-6: Installation Diagram of Oil Filter

### 3.6.3 Material storage bin (MST-80U-OP)

- 1) Check whether internal bin and connecting pipe are clean or not before using.
- 2) Optional with high-efficient HEPA to collocate with optional grade series.
- 3) If customer doesn't equip with HEPA, filter with accuracy of 5um is available, which is installed inside storage bin.



Picture 3-7: Material Stage Bin of Optical Grade MST-80U-OP

## 4. Application and Operation

### 4.1 Operation Procedure for HMI

- 1) Do not use keen-edged object instead of hands to operate the touch screen, and prevent violent collision of it.
- 2) In a dry environment, static electricity may accumulate on the touch screen. Use a metal wire to discharge it before operating.
- 3) Use alcohol or eleoptene to wipe off the pollutants on the screen. Other solvent may cause the color of the screen to fade out.
- 4) Do not tear down any parts of the touch screen or take away any PCBs attached to it.

#### 4.1.1 Description of touch screen



Picture 4-1: Description of touch screen

A: Display

B: Touch panel

#### 4.1.2 Touch panel appear error

Table 4-1: Touch panel information

LED indicator light	State
Green (light)	Work well
Orange (light)	Backlight lamp burning
Orange (shine)	During software startup
Red (light)	Power status
No shine	Power break off

### 4.1.3 Screen operation flow Table

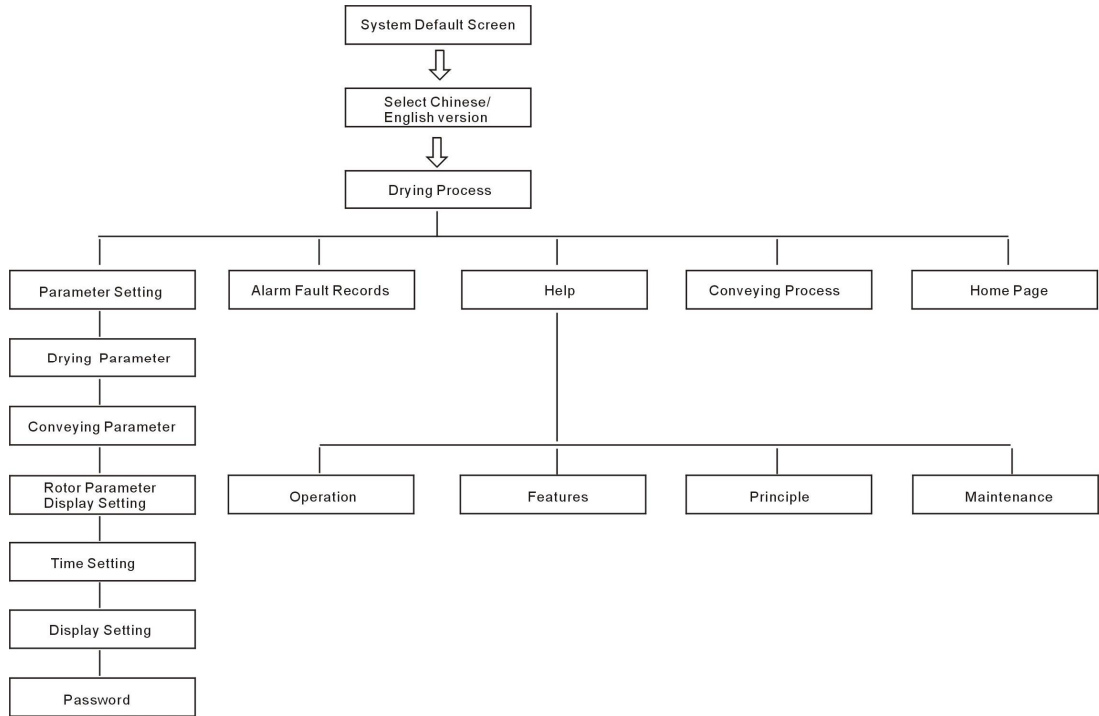

Picture 4-2: Screen operation flow table

### 4.1.4 Menu Particular

#### 4.1.4.1 System Default Screen

When the system is connected with power source, the initial default screen will display as shown below. By touching the button of "English" or "Chinese" to select either English or Chinese language in order to login "Drying Process" screen.

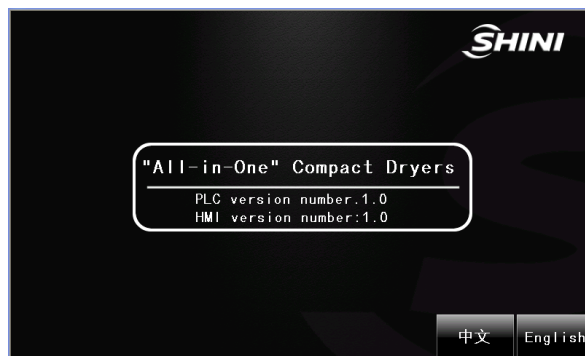

Picture 4-3: System initial screen

#### 4.1.4.2 Drying Monitoring

Drying Monitoring screen is shown as below:

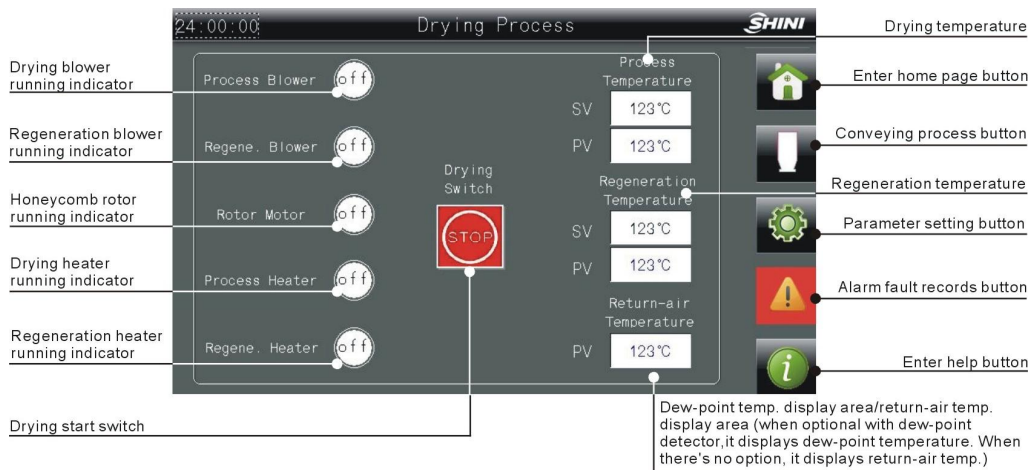

Picture 4-4: Drying process screen

#### Operation of the Menu

Start the system:

Touch the drying switch to make it show ON, then the drying and dehumidifying system starts.

Stop the system:

Touch the drying switch again to make it show OFF, then drying and dehumidifying system stops running.

(Attention: In order to prolong the life of honeycomb-rotor, it's necessary to delay the rotating time of the rotor for cooling. Set the delayed time at 3 minutes.)

Set drying temp. (Only suitable for SD-H-C, SD-H-PHC, SDD and SCD)

Touch the PV of process temp. A numerical keypad will appear. Use the keypad to input temperature values.

Touch the PV of regenerative temp. A keypad will appear. Use the keypad to input temperature values.

***Note: Drying temp. and regenerative temp. value are set within certain limits. The regenerating temp. value is already set to be 180°C before being delivered. Please don't reset it if no special occasion.***



#### 4.1.4.3 Conveying Monitoring (only suitable for SCD model)

By touching the "Conveying Process" button on the right of "Drying Process" screen, it will enter into conveying process screen as shown below:

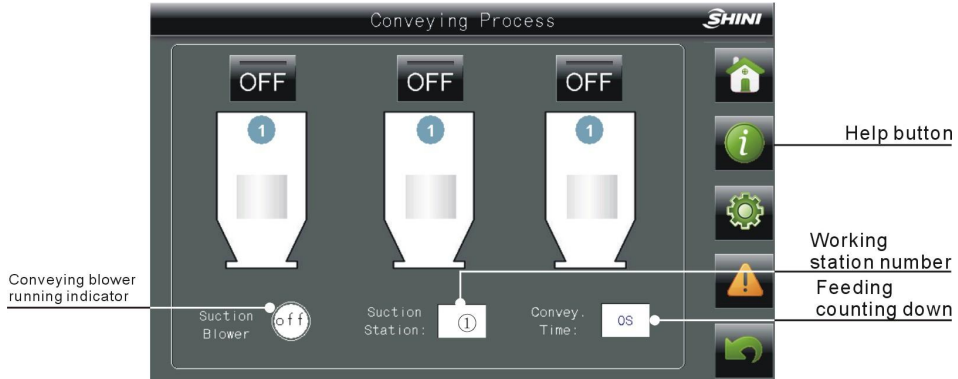

Picture 4-5: Conveying process screen

#### 4.1.4.4 Parameters Setting

Touch parameter setting button on the right of drying process screen or conveying process screen. Then, the system will pop out a password window for inputting user name: Shini, and passwords 3588. Press "ENTER" button to confirm. By then, the numeric keypad will turn off and return to the password window. After that, press "Unlock" and "Return" key by turn to go back to the drying process screen or conveying process screen. By pressing the "Parameter Setting" button again, you can log in and change parameters.

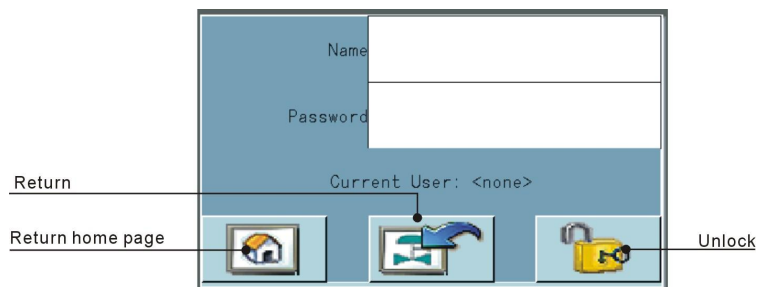

Picture 4-6: Password input screen

**Warning: Please keep this password securely and safely. If the password is missing, then the operator won't be able to log into the system parameter setting screen. It is better to let this password known only by system administrator or senior operator.**

After input correct password, the screen will show the following "Parameter Setting" screen. Shown as below:



Picture 4-7: Parameters setting

### B. Drying Parameter Setting

Click drying parameter button to enter into drying parameter screen, as below picture:



Picture 4-8: Temperature parameters setting 1

PID Setting:

By touching "PID" button, the system will pop up the PID setting screen.

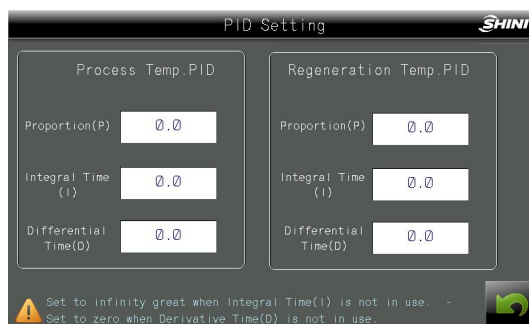

Picture 4-9: Temperature parameters setting 2

If to change any parameters, it's only need to touch the corresponding "input

area" and then a numeric keypad will pop up. Input a new parameter and press "ENTER" to confirm the new parameter.



Picture 4-10: Temperature parameters setting 3

The max. and min. display area of the numeric keypad shows the present max. and min. setting value. If the setting value exceeds the limits, it would be invalid to press "ENTER".

When temperature control is inaccurate, users can manually adjust PID parameters to achieve the best temperature control effect.

#### Adjustment of Proportion (P)

Table 4-2: Adjustment of proportion (P)

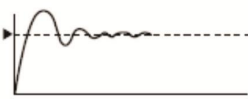
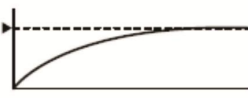
P increases		After the oscillation, the curve will be settled and back to setup point.
P decrease		The curve increases gradually in order to maintain a long reliable period against over oscillation.

#### Adjustment of Integral Time (I)

Table 4-3: Adjustment of integral time (I)

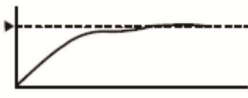
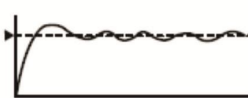
I increases		For default value requires a longer time for steady status. But, it still has over pulse/under pulse and oscillation occurs.
I decrease		After the occurrence of over pulse/under pulse and oscillation, but the curve tends to rise rapidly.

## Adjustment of Differential Time (D)

Table 4-4: Adjustment of differential time (D)

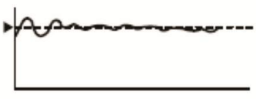
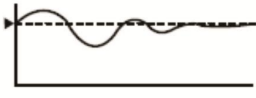
D increases		Over pulse/under pulse and steady time become less, but the curve has small oscillation.
D decrease		Over pulse/under pulse increases, the duration for setup value requires certain time.

### A. Conveying Parameter Setting (Only suitable for SCD)

Touch the "Conveying Parameter" button to enter into the conveying parameter screen. Parameters Conveying Time, Failure Alarm Counter and Shut-Off time can be set according to actual requirements.

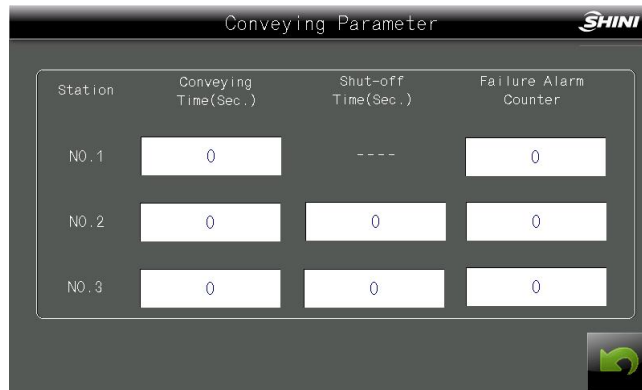

Picture 4-11: Conveying parameter setting

**Warning: All parameter default setting is done before delivery. Under normal condition, please DO NOT adjust the setting values.**

### Material feeding time (Unit: Second)

When system detects material shortage, it will count down for 3 seconds. After that, PLC will send out signals to start the suction motor for feeding the molding machine. At the same time, it will time the loading time. When the loading time is up, it will stop loading and add 1 to material loading times.

### Times of material shortage

For feeding the molding machine, it will limit the material loading times if there is still a material shortage signal. When it's up to the set loading times, the system will stop feeding the machine. Furthermore, it will send out an alarm signal of material loading fault to remind users to check whether the storage tank is lack of material or other faults caused loading failure.

Shut-off time (Unit: Second)

Shut-off time refers to opening time of relative shut-off valve. The longer the shut-off time, the more material will be discharged.

**Warning: Shut-off time should not be set for too long. Otherwise, some material will remain in the material line, which will affect the material drying effect.**

### C. Rotor Parameter

Click rotor parameter button on its setting screen to enter into this screen.

Pre-warning time is set as 5-10 mins. according to the model type.

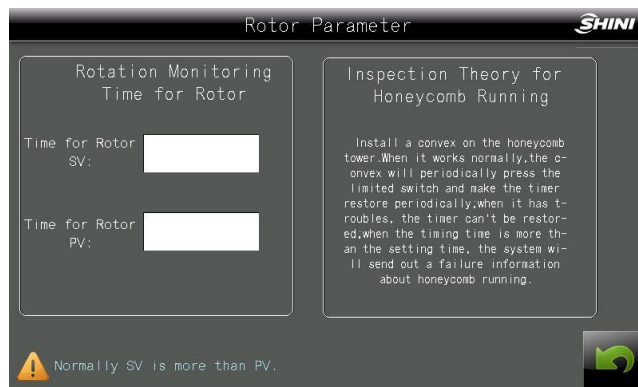

Picture 4-12: Rotor parameter screen

### D. Time Setting

Touch the " Time Setting " button to enter into Time Setting screen as shown below:



Picture 4-13: Time setting

**Note: After setting the auto-run time, pressing button "OFF" to activate one week timer. By then, the machine will run according to the set time.**

If there are some mistakes with the system date and time, touch the "PLC Time Setting" to enter into the PLC time setting screen to modify the system time. The screen is as below:

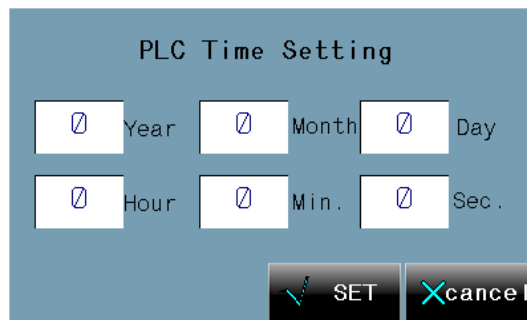

Picture 4-14: PLC time setting

After touching any parameter setting area, a numeric keypad will appear. Input each parameter and then press "SET". Then, the new setting comes into effect. The setting can be cancelled by pressing "cancel".

#### 4.1.4.5 Alarms Fault Records

Touch " Alarm Fault Records " button on the right of "Drying Process" screen or "Conveying Process" screen to enter into Alarm Fault Records screen. The screen is shown as below:



Picture 4-15: Alarm fault records

1. When alarm fault records cover more than displaying space, touch "Up" or "Down" keys to read more records.
2. According to the alarm information, the operator could get the troubleshooting information from the instruction book.
3. Press "EXIT" button to exit from this screen.

Table 4-5: Alarm Information List

Alert message	Range	Results	Possible causes
Anti-phase	SCD,SDD SD-H	System cannot operate, and the visible alarm is flickering.	Low voltage, anti-phase
Process blower overload.	SCD,SDD SD-H	Dehumidifier does not work and the visible alarm is flickering.	Incorrect motor overload setting, or motor burns out.
Regenerating blower overload.	SCD,SDD SD-H	Dehumidifier does not work and red alert light is flickering.	Incorrect motor overload setting, or motor burns out.
Conveying blower overload.	SCD	Material conveying stops and the visible alarm is flickering.	Incorrect motor overload setting, or motor burns out.
No.1 receiver suction problem	SCD	No.1 receiver stop suction function and the visible alarm is flickering.	Storage tank lacks material, suction probe problem, parameter wrongly setting, shut-off valve damaged.
No.2 receiver suction problem	SCD	No.2 receiver stop suction function and the visible alarm is flickering.	Drying hopper lacks material, suction box problem, parameter wrongly set, shut-off valve damaged.
No.3 receiver suction problem	SCD	No.3 receiver stop suction function and the visible alarm is flickering.	Drying hopper lacks material, suction box problem, parameter wrongly set, shut-off valve damaged
Process temperature overheat	SDD,SCD	Dehumidifier does not work and the visible alarm is flickering.	Temperature control parameter wrongly setup, touching pad is malfunction, process heating problem.
Regenerating temp.overheat	SCD,SDD SD-H	Alarm display on screen	1. Temperature control parameter set envi 2. Contactor fail 3. Thermocouple fail
Temp. overheat	SCD,SDD SD-H	Message display screen	No water supply or high water temperature.
Process temp. Thermople broken	SDD,SCD	Dehumidifier does not work and the visible alarm is flickering.	Thermocouple disconnected or bad contact.
Regenerating temp. Thermocouple broken	SCD,SDD SD-H	Dehumidifier does not work and the visible alarm is flickering.	Thermocouple disconnected or bad contact.
Rotor is not working	SCD,SDD SD-H	Dehumidifier stop and the visible alarm is flickering.	Rotor driving motor burnt, belt broken, micro switch fail, or incorrect rotor speed monitoring parameter setting.
PLC is not under operation mode	SCD,SDD SD-H	System stops.	PLC work mode is not in RUN mode.

- Note: 1) Overload Relay reset: Open control box, press "RESET" button on the corresponding overload relay.  
 2) Rotor Failure Alarm reset: Turn off the Drying Switch and then turn it "ON" again.  
 3) Over Temperature Alarm reset: Turn off the Drying Switch and then turn it "ON" again after the temperature drops down.



#### 4.1.4.6 Help Screen

Touch "Help" button on the right of Drying Monitoring or Conveying Monitoring screen to enter into system help menu screen. Touch the menu button to get corresponding help message.

The help screen consists of several interconnected screens:

- Help Menu:** A central menu with buttons for "Operations", "Features", "Principle", and "Maintenance".
- Operation 1:** Provides instructions for starting the system, such as switching on the power supply and setting the process temperature.
- Solution 1:** A troubleshooting table for "System Reversed Phase" and "Alarm reset".
- Maintenance 1:** Lists seven maintenance tasks, including cleaning filters and the desiccant rotor.
- Features 1:** Describes the system's design for drying hygroscopic materials, its PLC control system, and its insulated drying hopper.
- SCD Working Principle:** A detailed schematic diagram of the material flow and air handling process, showing components like the vacuum hopper, drying hopper, honeycomb rotor, and various filters.

Picture 4-16: Help Screen

## 5. Trouble-shooting

Symptom	Possible causes	Actions taken
Alarm light for high dew point	1. Return air temperature too high	1. Check cooling water temperature (below 40°C)
	2. Abnormal setting of regenerating temperature	2. Set the regenerating temperature again(Default value H5 is 180°C, H4 is 150°C)
	3. Rotation wheel blocked	3. Clean or wash rotor
	4. Filter is blocked	4. Clean or replacement
	5. Leakage of heat-resistant hose	5. Check pipe and connector
	6. Operating time is less than 30 minutes	6. Wait until 30 minutes later for confirmation
	7. Rotation wheel is not working	7. Check motor, micro switch, belt is damage or not
	8. Motor's direction is wrong	8. Check motor's direction
	9. System drying capacity insufficient	9. Replace with a large system
	10. Honey-comb upper/lower lid is leaking	10. service or change the seal components
System cannot operate	1. Main AC power supply unconnected	1. Close main AC power supply
	2. Put timer switch into ON status	2. Reset timer button and restart again
	3. Motor overload or Phase reverse	3. Check close-loop, regenerative motor and AC power source are connected correctly
Lack material for a long time but suction blower don't work	1. Main AC power source unconnected or conveying is not in ON position	1. Turn on main AC power source
	2. Photo sensor, micro switch are bad contact	2. Adjust or replace
	3. Signal cable is broken	3. Re-connect or replace
Motor does not run	1. Heat relay off load	1. Check reason and reset
	2. Connector is not working	2. Check it is burnt out or not
	3. Power source lack of phase or motor is burnt out	3. Check and replace
Material is full but suction blower still working	1. Photo sensor or micro switch is On status	1. Adjust or replace
	2. Signal's cable is broken	2. Check signal cable
	3. Mechanical problem or contactor fail	3. Repair or Replace
	4. PLC problem	4. Check and replace
Continuous running but cannot fill up hopper receiver	1. Material is empty	1. To add more materials
	2. Pipe leakage	2. Repair or replace
	3. Filter is blocked	3. Clean
	4. Diaphragm valve or shutoff valve is closed	4. Check diaphragm valve or shutoff valve's pressure, electric valve may be burnt out, circuit is well connected or not
	5. Blower blade problem	5. Check and repair

## 6. Maintenance and Repair

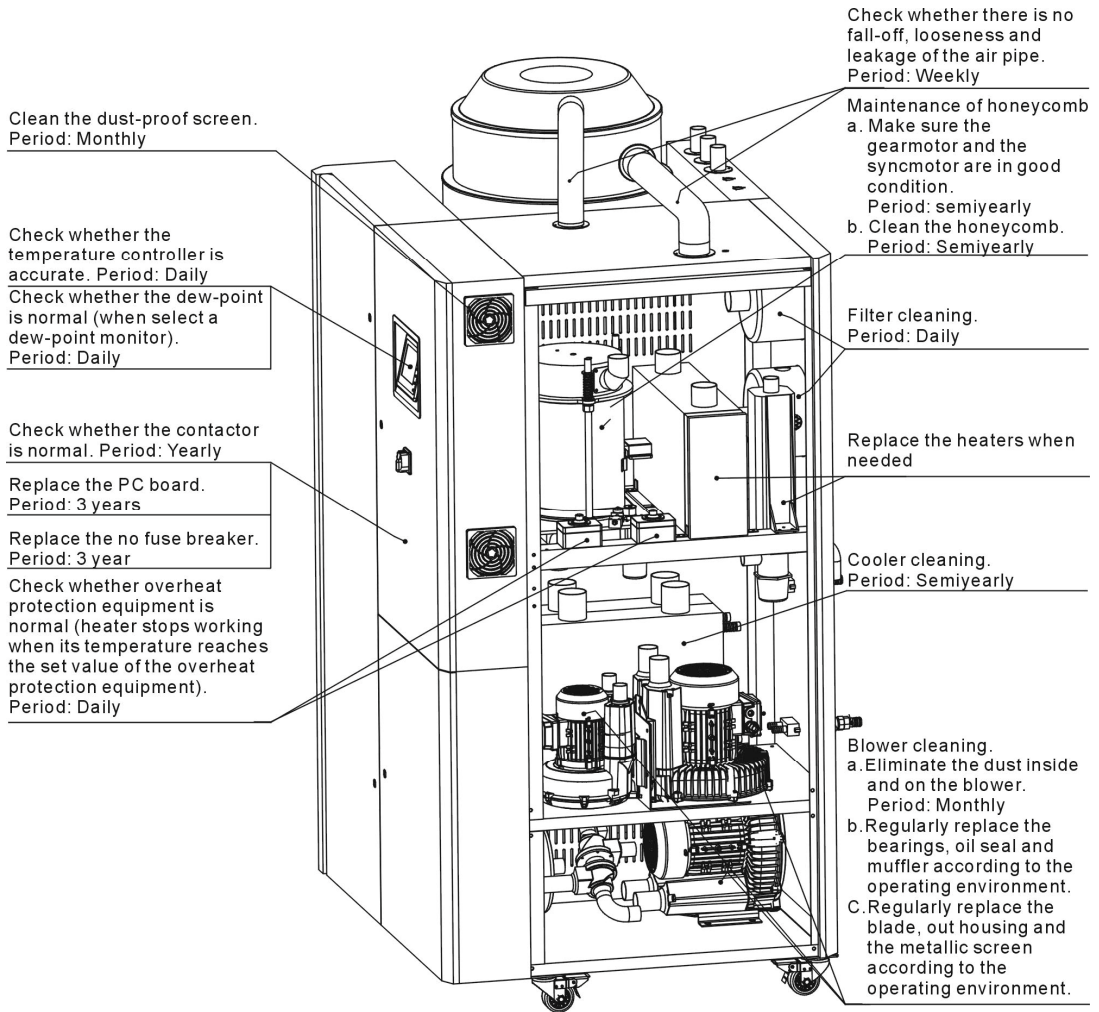

## 6.1 Filter & Pressure Regulating Valve

### 6.1.1 Filter & Pressure Regulating Valve Drawing

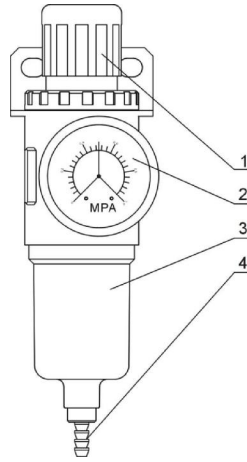

Picture 6-1: Filter & Pressure Regulating Valve Drawing

Table 6-1: Filter & Pressure Regulating Valve Assembly

No.	Component	Function
1	Pressure adjusting knob	Used for adjusting the air pressure at the outlet
2	Pressure gauge	Used for displaying air pressure at the outlet
3	Cup	Used for storage the moisture filtered from the air
4	Water outlet	Used for discharging the moisture in the glass

### 6.1.2 Filter & Pressure Regulating Valve Operation steps

- 1) Switch on the air source.
- 2) Pull the black pressure adjusting knob 1 upward and rotate it, observe the pressure gauge 2, generally a 0.5 Mpa pressure is advisable.
- 3) Push back the black knob 1.

## 6.2 Air Filters

Please periodically clean the dust on the air filters, once per week.

Cleaning steps:

- 1) Take out the air filter carefully.
- 2) Blow off the dust on the air filter screen and the cover with pressure air.
- 3) Wipe off the barrel wall of air filter with cloth.
- 4) After cleaning, place all parts in reversed order carefully.

5) Please ensure that the filter is well sealed with metal frame.



Picture 6-2: Filter Cleaning



Note!

Don't let foreign object enter into the barrel, when taking out the air filter.

## 6.3 Blower Motors

### 6.3.1 Drying Blower

- 1) Fix inlet/outlet flange of blower, and tighten four screws securely.
- 2) Connect the blower with electrical source.
- 3) Install the blower on the Machine frame.



Picture 6-3: Installation of Blowers

### 6.3.2 Regeneration Blower

- 1) Fix inlet/outlet flange of blower, and tighten 4 screws securely.
- 2) Install the blower on the machine frame.
- 3) Connect the blower with electrical source.

### 6.3.3 Conveying Blower

- 1) Fix inlet/outlet flange of blower, and tighten 4 screws securely.
- 2) Connect the blower with electrical power source.
- 3) Install the blower on the machine frame.

- 4) Fix the three-way valve (See Figure. 1).
- 5) Install the solenoid valve, and then tighten 2 screws on the machine frame (See Figure. 2).



Picture 6-4: Conveying Blower

#### 6.3.4 Blower Cleaning

- 1) To clean blower both internal and external parts (especially the fan cooling path), by removing surface dust. If more dusts are accumulated, it will cause deficiency for ventilation, temperature rising up, blower power reduced, vibration increased and so it will cause machine broke down.
- 2) Ball bearing, oil seal and sound-proof are belonging to consumable parts and so it has a life period and requires regular replacement.



Picture 6-5: Blower

## 6.4 The Service Life of the Key Parts of the Product

Table 6-2: The Service Life of the Key Parts of the Product

No.	Name of the Parts	Useful Life
1	Blower	Above 5 years
2	Process heater	Above 1 year
3	Regen. herter	Above 1 year
4	Contactora	Above 2000,000 act
5	Honeycomb	5 years
6	Filter	1 year

## 6.5 Honeycomb-rotor

### 6.5.1 What is Honeycomb-rotor

The main body of the honeycomb-rotor is a honeycomb, made by ceramic fibre and organic additives, sintered under high temperature with molecular sieve and silica gel, to be strongly bonded together and form a solid and hard surface. Not like common molecular sieve, which will produce dusts and fines to pollute raw materials when aging or become saturated requiring regular replacement, the moisture of return air is quickly absorbed by numerous tunnels before coming out of the rotor to form low dew-point air. At the same time, regenerating blower takes dry air into the honeycomb-rotor from an opposite direction to regenerate the rotor.

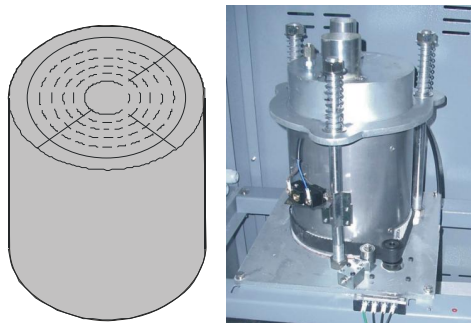

Picture 6-6: Honeycomb Rotor

### 6.5.2 Installation Steps of the Rotor

- 1) The upper and lower lid of honey-comb should install Teflon gasket (Fig. 1).
- 2) Use 4 screws to fix the rotor base on the machine frame firmly, and then install the shaft accordingly (Fig. 2).
- 3) Install the gearmotor and transmission gear (Fig. 4).
- 4) Install and fix the main support screws (Fig. 3).
- 5) Fit the transmission belt in proper position (Fig. 6).
- 6) Install the honeycomb-rotor (Fig. 9) and transmission belt (Fig. 12).
- 7) Fix the rotor top cover (Fig. 8).
- 8) Fit all springs and tighten the screws (Fig. 7).
- 9) Install both the transmission belt (Fig. 13) and belt tension regulator (Fig. 14).

10) Install micro-switch and fixed board firmly (Fig. 10).

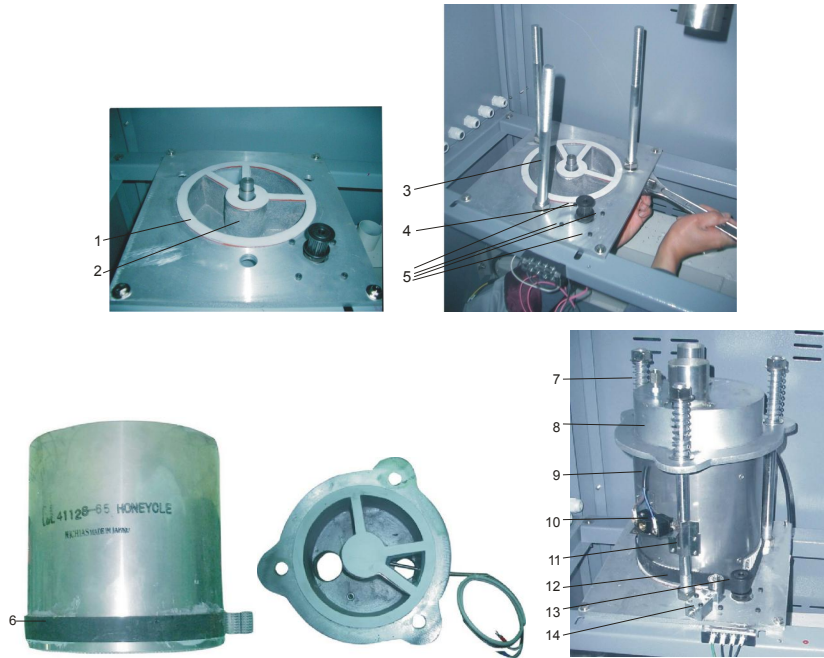

Picture 6-7: Rotor Installation Diagram

#### Honeycomb Rotor Cleaning Steps:

Use a vacuum-cleaner with brush to suck up the dust on rotor surface.

Blow off the dust in the rotor channels with compressed air.

If there is dirt sticking to the channel walls inside the rotor, cleaning steps as follows:

- 1) Saturate the rotor by blowing humid air (higher than 60%RH) through the rotor without having regeneration circuit on. This can be done by just turning the regeneration heater off and still have the process blower running if process air has high humidity. If the process air is too dry try to put a humidifier in the air stream. Do this for one hour.
- 2) Depending on the character of the dirt, sink the rotor into water with cleaning agent in it (PH value 3~2 liquid is applied to silica gel, PH value 7~10 applied to molecular valve). Greasy dirt should be put into a detergent solution with xylene. 15 minutes cleaning is suggested.
- 3) Take the rotor out of the liquid and let it rest with the channels vertically for 5 minutes so the liquid can run out.



- 4) Blow off the residual liquid in the channels with compressed air.
- 5) Put the rotor back into the dehumidifier and run the unit with regeneration circuit (the regeneration temperature between 50°C and 60°C) on for at least one hour.

**Note: In the dry air and wet air outlets, there will be high concentrations liquid out for some time. If a solvent has been used, there will be a residual smell for several days.**

**Note: For some dirt which is greasy and sticky in the rotor, 100% elimination is impossible. The only one thing you can do is to replace the rotor for the cleaned rotor performance can only be recovered partly.**

## 6.6 EGO

Table 6-3: EGO Default Value

No.	Category	Default Value
1	Drying	200°C
2	Regenerating	200°C



Picture 6-8: EGO

**Note: EGO is mainly used for protecting highest heating temperature, other than drying temperature. EGO has been set before delivery, unauthorized modification is not permitted!**

## 6.7 Cooler

- 1) Clean the cooler and eliminate the leakage regularly.
- 2) Please do the above-mentioned job once a month for cooling by chilled water.
- 3) As for the cooling by normal water, do the same job once a quarter.

## Cooler Cleaning Step

- 1) Disassemble the cooler's pipe and screw, and remove the cooler out of the chiller.
- 2) Release the fixed screw on the upper and lower cover of cooler and disassemble the cover.
- 3) Use brushes, compressed air or low pressure water to clean the dust and sundries on the cooler fan and copper pipe.
- 4) Make the cooler's upper and lower cover junction clean enough and smear the silica gel then fixed the covers with screws.
- 5) Put the cooler on the air at least four hours to make the silica gel drying enough then fix the cooler on the chiller and connect all pipes.

## 6.8 Maintenance Schedule

### 6.8.1 General Machine Information

Model \_\_\_\_\_ SN \_\_\_\_\_ Manufacture date \_\_\_\_\_

Voltage \_\_\_\_\_  $\Phi$  \_\_\_\_\_ V Frequency \_\_\_\_\_ Hz Power \_\_\_\_\_ kW

### 6.8.2 Installation & Inspection

- Check if the air pipe are tightly connected.
- Check if the material clearance door tightly closed.
- Check if the air pipes are correctly connected.
- Check if there are damages of the honeycomb.

#### Inspection of Electric Components

- Voltage \_\_\_\_\_ V \_\_\_\_\_ Hz
- Fuse melt current: 1 Phase \_\_\_\_\_ A 3 Phases \_\_\_\_\_ A
- Check phase sequence of the power supply.
- Check the rotating direction of regeneration blower.
- Check the rotating direction of conveying blower.

#### Check Air Supply of Compressor

- Compressed air pressure \_\_\_\_\_ bar
- Air flow \_\_\_\_\_ L/min
- Check if the compressed air purified or not

### 6.8.3 Daily Checking

- Check the switch of the machine.
- Check auto start-up of the machine.
- Check the temperature controller.
- Clean the filter.
- Check whether overheat protection is normal.
- Check whether dew-point is normal.

### 6.8.4 Weekly Checking

- Check all the electric wires.
- Check loose electric connections.
- Check and clean compressed air filter and regulator.
- Check magnetic valve.
- Check motor overload relay and phase-reversed prevention function.
- Check whether air pipe is shed, leaked and loose.

#### 6.8.5 Monthly Checking

- Check if the belt is loose or not.
- Check gear box working conditions.
- Check if there are leakages in the honeycomb.

#### 6.8.6 Half-yearly Checking

- Check if hot air pipe is broken or not.
- Check dehumidifier heater.
- Check regulation blower/material conveying blower/fans.
- Check whether honey-comb rotor belt is damaged.
- Clean the cooler.

#### 6.8.7 Yearly Checking

- Check whether the contactor is normal <sup>1</sup>.

#### 6.8.8 3 year Checking

- PC board renewal.
- No fuse breaker renewal.

Note: 1. Manufacturer laboratory data for AC contactor is two million times in life. we suggest service life for one million four hundred thousand times, if work eight hours per day, recommended replacing frequency is 1.5 years, if work day and night, replacement is suggested to be done every six months.