

序号	代号	名称	材质	数量	备注
30	YW640814.00000	Hex. nut GR753 M8-Longpin		4	
29	SCAD-1U-A-16	discharge port cover	SH201	1	
28	SCAD-1U-A-15	base	SH201	1	
27	YW66081900000	Flat washer GR162, 8mmpin		4	
26	YW65008000100	Standard spring washer GR793 9-Longpin		4	
25	YW61088000000	inner hexagon cylinder screw GR770 1 M8x10-12.9-Longpin		4	
24	SCAD-1U-A-05	Control box flange plate	SH201	1	
23	SCAD-1U-A-14	flint-off plate	SH201	1	
22	BR90011300110	Hopper base SCAD-1U-A-13 Ver. A (Top)up	PFB	1	
21	SCAD-1U-A-01	Hopper	Weldment	1	
20	SCAD-1U-A-12	Upper flange 2 of hopper	SH201	1	
19	BH1103300110	Connecting rod SCAD-1U-A-03 Ver. A (SH201)	SH201	4	
18	YW61062000500	inner hexagon counter-nut head screw GR770.3 M8x10-A3-19 (STD)		4	
17	YR50880700000	flow control valve with suspension mechanism in SCAD-1U-A-14 Assembly		1	
16	YR400104.00000	Flange star nut black 1/4" (Q194 hpl)		1	
15	YW70765300000	pin dia. 6x6 304(SS) steel wire pin hexagon nut-M8x10	stainless	1	
14	SCAD-1U-A-10	inner glass pipe fastener	WTF	2	
13	SCAD-1U-A-09	Flange flange plate	SH201	1	
12	YR20258900000	Rubber O-type seal ring 1.940 (sect. 61x)	rubber	1	
11	YW69616100000	head screw M6x16		3	
10	YW61051000100	inner hexagon counter-nut head screw GR770.3 M8x10-12.9-Longpin		2	
9	SCAD-1U-A-08	Filter pressure block	SH201	2	
8	BH13301000010	Hopper upper ring SCAD-1U-A-02 (G110)	AC10	1	
7	SCAD-1U-A-07	Ext. glass pipe fastener	silicon	2	
6	YR40132500000	transparent acrylic tube Ø120xØ120x1250x4.20	Acrylic	1	
5	YR20535000000	O-ring seal Øinner 81 * dia. Øouter 115 Fluoroelast.	silicon rubber	2	
4	BH1106300110	Ø120xØ120 height 120mm 1 Ø120mm for base hole of Hopper	SH201	1	
3	BR900104.00110	base ring stainless pipe M8x10-12.9-Longpin, section 1 (SH201)	PFB	1	
2	YR20101800000	O-ring 18 * 4.5 Ø 18/17.5x1.9 1000 9011000 redrub	silicon rubber	4	
1	BH11116000010	Connector SCAD-1U-A-09 (SH201-A)	SH201	2	

标记				制图	版号	标题	图号	比例	数量
更改前	更改后	更改人	日期	设计	核	SCAD-1U	SCAD-1U-A-ALL	1:4	
				校	准	干燥桶			材质
				对		SHINI 信易电热机械股份有限公司 Shini Plastics Technologies, Inc.		表面要求	
				日	日期			物料号	

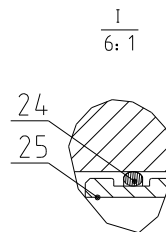
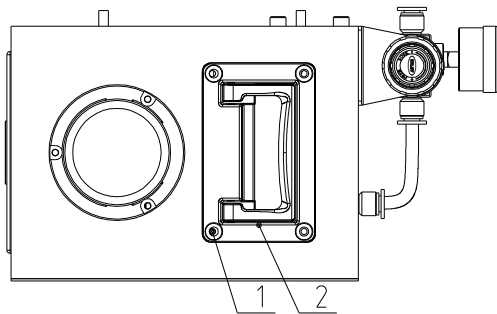
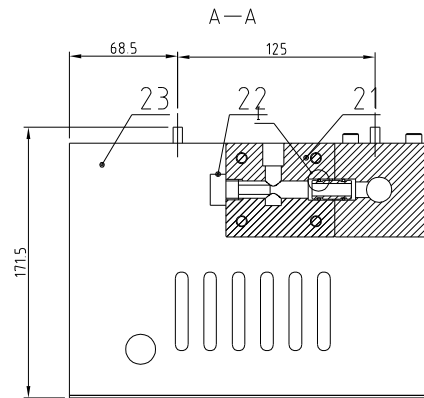
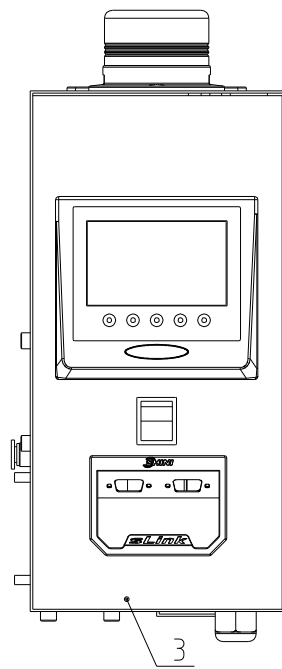
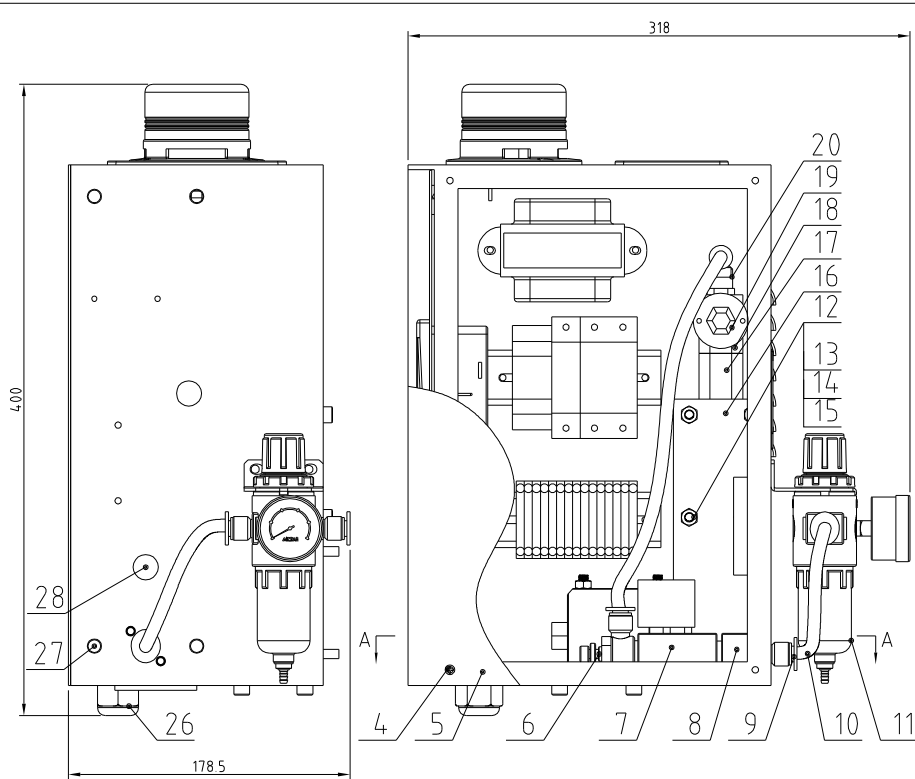

28	YR30001600000	Reserved hole plug for control box Φ 14 H7-D6	2	
27	YW61081000200	Inner hexagon cylinder screw GB/T91.1 M6x1.6-L=longpin	4	
26	YE67181500100	Agar shield hole with nut GB91.1 L4 Hx L5-L=total Brass	1	
25	BH1116000010	Connector SCAD-1U-B-03 (SUS304)	SUS304	1
24	YR20101800000	4 type seal ring 1.4140/202.5-193.011mm outer 211mm rubber	2	
23	SCAD-1U-B-10	Control box	Weldment	1
22	YE90052400300	Thermoplastic 5-6-40-1.5E 6020-212-4-27 Ver.0	Assembly	1
21	BR90010800110	Heating box II 820-10-0-01 Heating terminal A (Orfinol) PTFE	PTFE	1
20	YW80081200000	L type screw connector T18-41 1/2-0-041r YAG18 gal/pack	Assembly	1
19	YE15020400300	Pressure switch LF24C12h	Assembly	1
18	BH12111500110	Three way tee 820-10-0-11 Drawing version A B20	BS8	1
17	BH40108000050	Pipe heater SCAD-1U-B-06	Assembly	1
16	BR90101000010	Heating box SCAD-10-0-01 (version A) Orfinol	PTFE	1
15	YW69067700000	Cover socket gas head screw GB718 H8 M6x7-10g plastic-white	Assembly	8
14	YW64000600300	Hex. nut GB/T6170 M6-Longpin	Assembly	8
13	YW65006000100	Standard spring washer GB/T93 6-Longpin	Assembly	8
12	YW66061300000	Flat washer A grade GB/T97.1 6-Longpin	Assembly	8
11	YE30200020000	Filter pressure regulating valve JPR-3004	Assembly	1
10	YR60000800000	FU air pipe Φ8-Φ6 black 100W/roll	Assembly	0.5
9	YW80081400000	Thread straight hole JPC-01 1/4- 0.1 GAO 10 pieces/pack	Assembly	3
8	BH12104500110	10 barrel seal in 20 standard seal, 220-20-20-01 single valve I BS8	Assembly	1
7	YE32382400000	Shielding plate Φ40x20x2mm and 200x20x2mm stainless steel	Assembly	1
6	YW80083800000	Adjustable air pipe connector HSA-10010 gal/pack	Assembly	1
5	SCAD-1U-B-03	Slide plate	SPOC1.5	1
4	YW67051000700	Cover socket gas head self-tapping lock screw GB6199 5-14-Longpin	Assembly	6
3	SCAD-1U-B-02	Door plank	SPOC1.2	1
2	YW06387300500	Electric supply cable hole 20-20-100 100x100x100mm 10-B	Straitite	1
1	YW61041000100	Cover socket connector tank head screw GB113 M6x10-Longpin	Assembly	4

序号	代号	名称	材质	数量	备注
		标题 SCAD-1U	图号 SCAD-1U-B-ALL	比例 1:3	数量
		控制箱		材质	
				表面要求	
				物料号	

标记	更改前	更改后	更改人	日期	审核	日期

制图	版号	标题	图号	比例	数量
		SCAD-1U	SCAD-1U-B-ALL	1:3	
设计	核准	控制箱		材质	
校对	核准			表面要求	
审核	核准			物料号	

SHINI 信易电热机械股份有限公司
Shini Plastics Technologies, Inc.

Model Version	Ver B
Hopper capacity	3L
Heater power	0.3KW
Control air flow	≥100L/min
Control air pressure	6~10Mpa

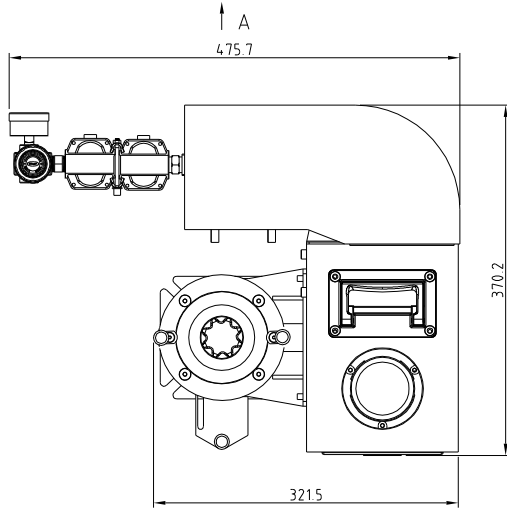
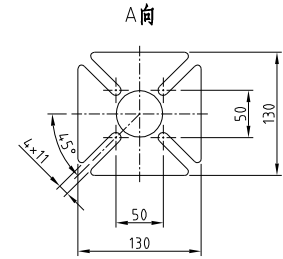
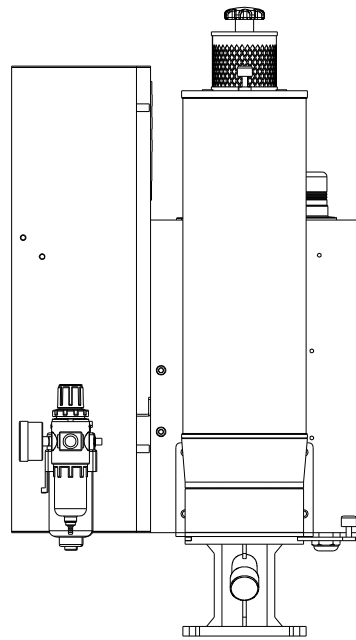
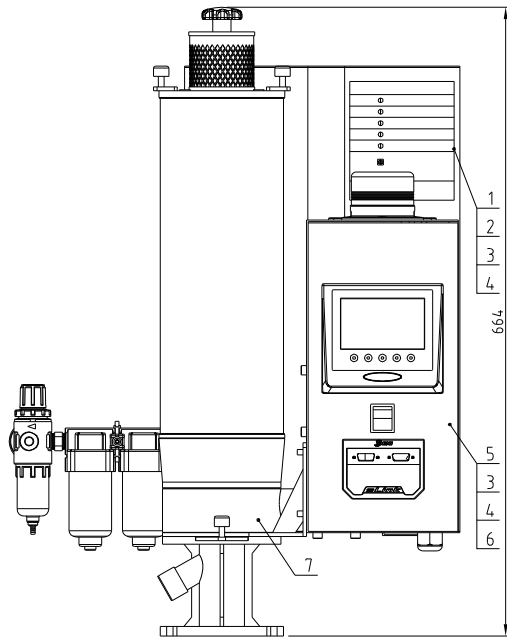

序号	代号	名称	材料	数量	备注
7	SCAD-3U-A-ALL	Drying hopper	Assembly	1	
6	YW64.008000100	Hexagon cap nut GB/T923 M8-A2-70		4	
5	SCAD-3U-HD-A-ALL	Control box	Assembly	1	
4	YW65008000100	Standard spring washer GB/T93 8-Longzine		16	
3	YW66081600000	Flat washer A grade GB/T97 18.4*16*1.6Longzine		16	
2	YW60081600100	Hexagon bolt GB/T5781 M8*16-4.8-Longzine		8	
1	SCAD-3U-HD-B-ALL	Dehumidifier assembly	Assembly	1	

标记	更改前	更改后	更改人	日期	制图	版号	标题	图号	比例	数量	备注
					设计	核准	SCAD-3U-HD		1:1	4	
					校对		空压式干燥机				
					审核		信易电热机械股份有限公司 Shini Plastics Technologies, Inc.		表面要求		
					日期			物料号			

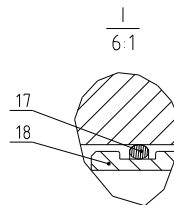
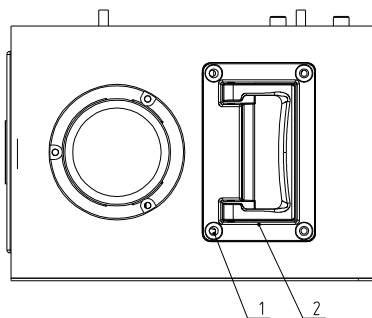
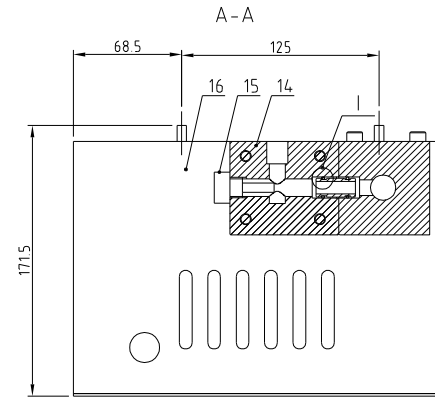
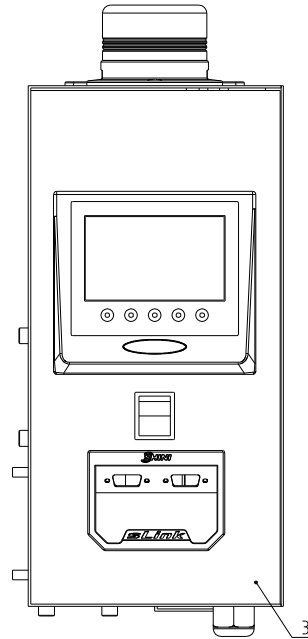
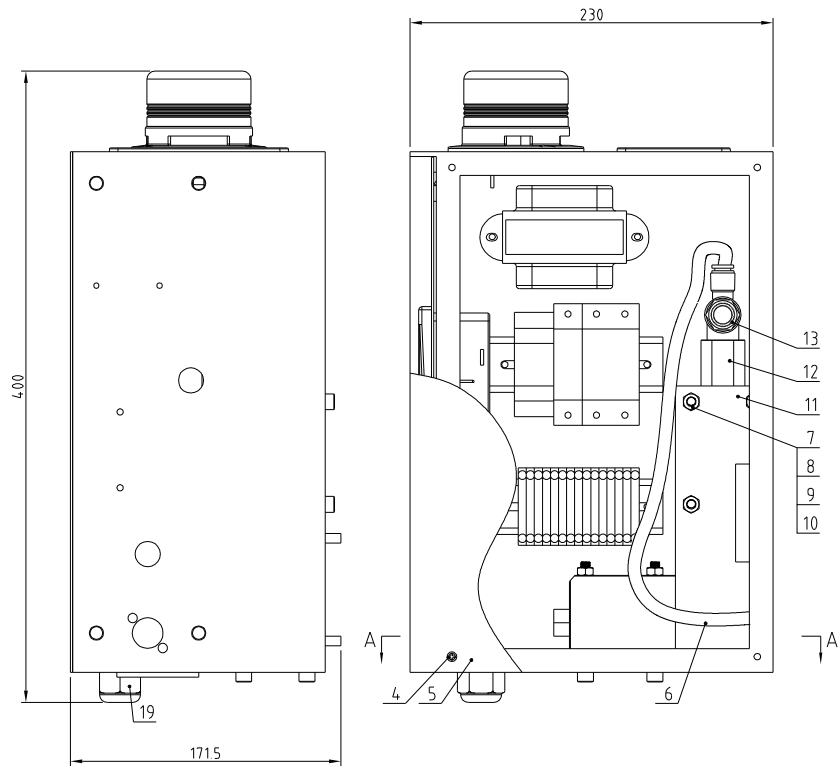

19	YE67181500100	Upper metal plate connector L10 M6 x 10 for PU cable	SUS304	1	
18	BH11116000010	connector SCAD-3U-B-09(SUS304)	SUS304	1	
17	YR20101800000	O-type seal ring 16x18.5 GB/T 3452.1-1992(Seal ring) weldment		4	
16	SCAD-3U-B-10	Control box	weldment	1	
15	YE90052400300	Thermocouple S-12-M6x1.5M SCAD-3U-B-17 Ver.01	assembly	1	
14	BR90010800110	Heating box 2 SCAD-3U-B-08 (Fluon PTFE) version A	PTFE	1	
13	YW81120800000	Label holder (ignition control valve) PU-A110-4 #1 (ign. valve)	assembly	1	
12	BH40108000050	Heater pipe SCAD-3U-B-06	assembly	1	
11	BR90101000010	heating box SCAD-3U-B-07 (Version A) (Fluon)	PTFE	1	
10	YW69067700000	Cross recessed pan head screw GB/T 818 M6x10-zinc plating-white		8	
9	YW64000600300	Hexagon nut GB/T 6170 M6-Longzinc		8	
8	YW65006000100	Standard spring washer GB/T 931.6-Longzinc		8	
7	YW66061300000	Flat washer A grade GB/T 971.1-Longzinc		8	
6	YR60805000000	air pipe M6x5mmx100ml(Air TAC)black	PU	0.5	
5	SCAD-3U-B-03	side plate	SPCC15	1	
4	YW67051000700	Cross recessed pan head self-tapping screw GB2818 5.8-Longzinc		6	
3	SCAD-3U-B-02	door plank	SPCC12	1	
2	YW06387300500	Zinc alloy zinc-nickel handle 302-407-3-2022 Hand Push position 100 x 10		1	
1	YW61041000100	Cross recessed counter sunk head screw GB2818 M6-Longzinc	steel	4	

序号	代号	名称	材质	数量	备注
		标题 SCAD-3U-HD	图号		比例
		控制箱			数量
		信易电热机械股份有限公司 Shini Plastics Technologies, Inc.	材质		
			表面要求		
标记	更改前	更改后	更改人	日期	物料号

制图	版号
设计	核准
校对	审核
标记	日期

Model Version	Ver B
Hopper capacity	3L
Heater power	0.3KW
Compressed air flow	≥ 4.0L/min
Compressed air pressure	6~10Mpa

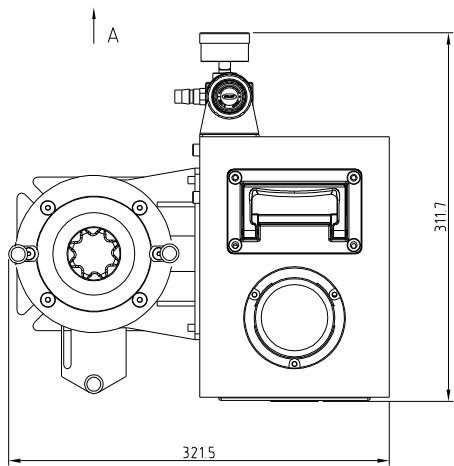
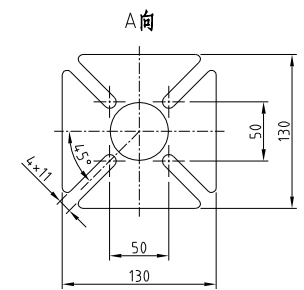
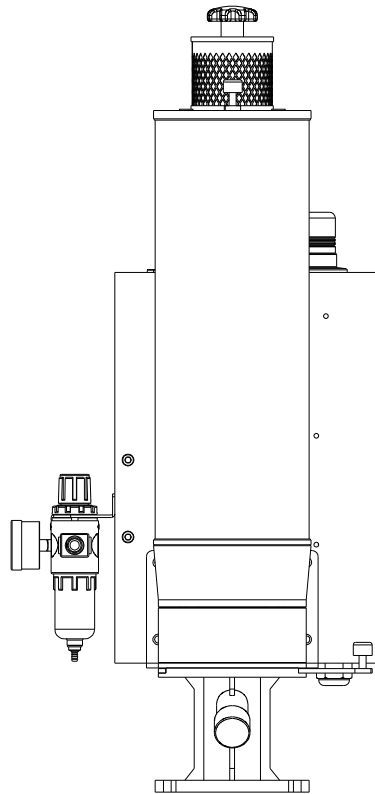
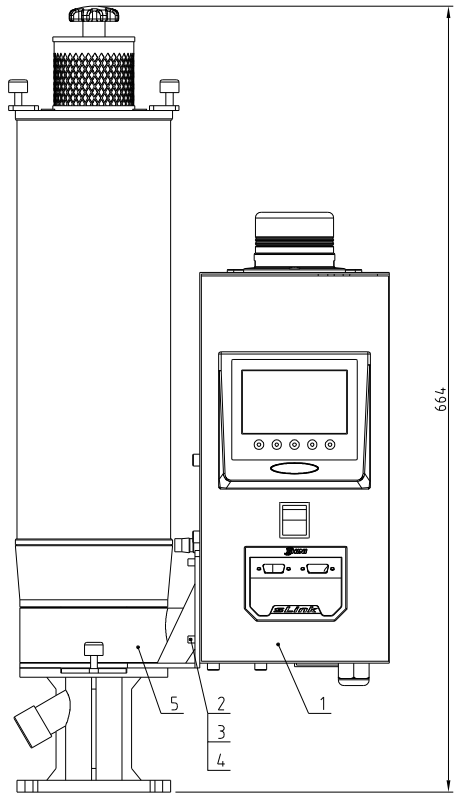

5	SCAD-3U-A-ALL	Drying hopper	Component	1	
4	YW64-008000100	Hexagon cap nut GB/T923 MB-A2-70		4	
3	YW66081900000	Flat washer A grade GB/T9711.8-Longzine		4	
2	YW65008000100	Standard spring washer GB/T93.8-Longzine		4	
1	SCAD-1U-B-ALL	Control box	Component	1	Borrowed
序号	代号	名称	材质	数量	备注

					制图	版号	标题	SCAD-3U	图号	比例	1:4	数量
					设计	核准	空压式干燥机			表面要求		材质
					校对		信易电热机械股份有限公司 Shini Plastics Technologies, Inc.			物料号		
标记	更改前	更改后	更改人	日期	审核	日期						

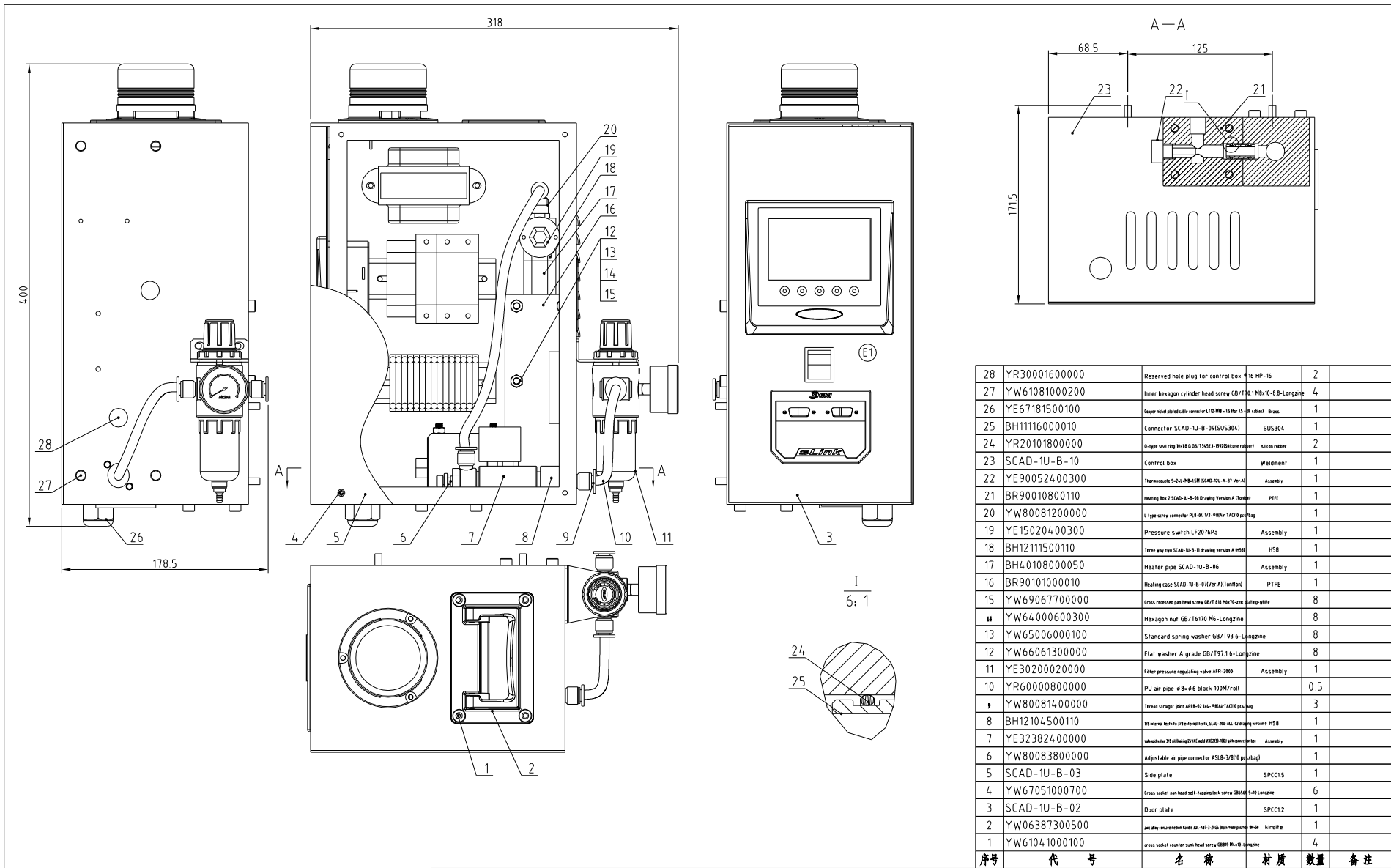

制图	版号	标题	SCAD-1U	图号		比例	1:3	数量	
设计	核准	控制箱						材质	
校对	日期			信易电热机械股份有限公司 Shini Plastics Technologies, Inc.		表面要求		物料号	
标记	更改前	更改后	更改人	日期	审核	日期			

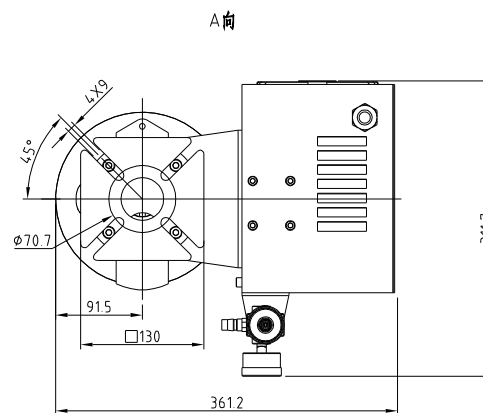
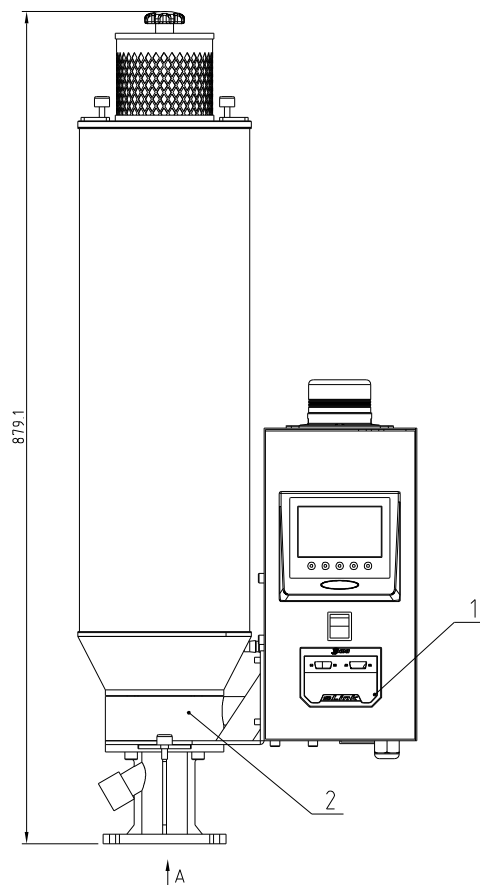

Tech. Req:
 1 Compressed air flow $\geq 60\text{L/min}$;
 2 Power: 1PH230VAC $\pm 5\%$ Hz;
 3 Before assembly, it's necessary to clean it thoroughly without scratch on the surface;
 4 The parameters are as below:
 Machine total power: 300W
 Drying hopper capacity: 6L

2	SCAD-6U-A-ALL	Drying hopper	Component	1	
1	SCAD-1U-B-ALL	Control box	Component	1	Borrowed
序号	代号	名称	材质	数量	备注

					制图	版号	标题	图号	比例	数量
					设计	核	SCAD-6U	SCAD-6U-ALL	1:1	1
					校对	准	空压式干燥机		表面要求	材质
标记	更改前	更改后	更改人	日期	审核	日期	信易电热机械股份有限公司 Shini Plastics Technologies, Inc.		表面要求	物料号

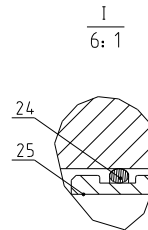
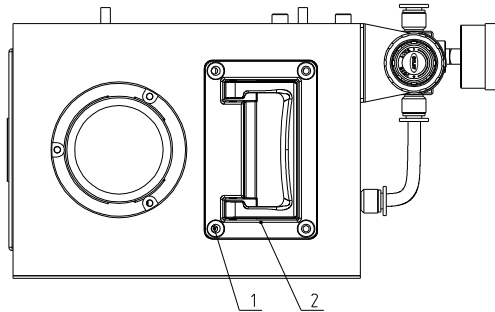
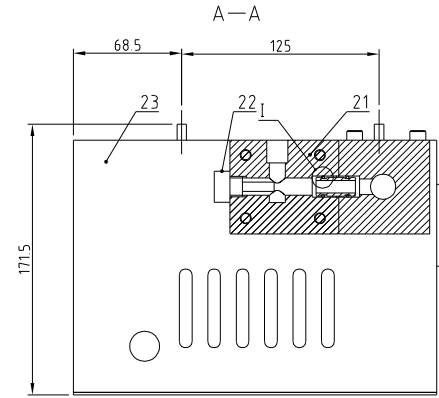
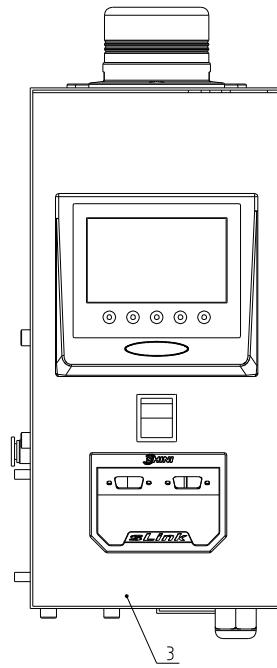
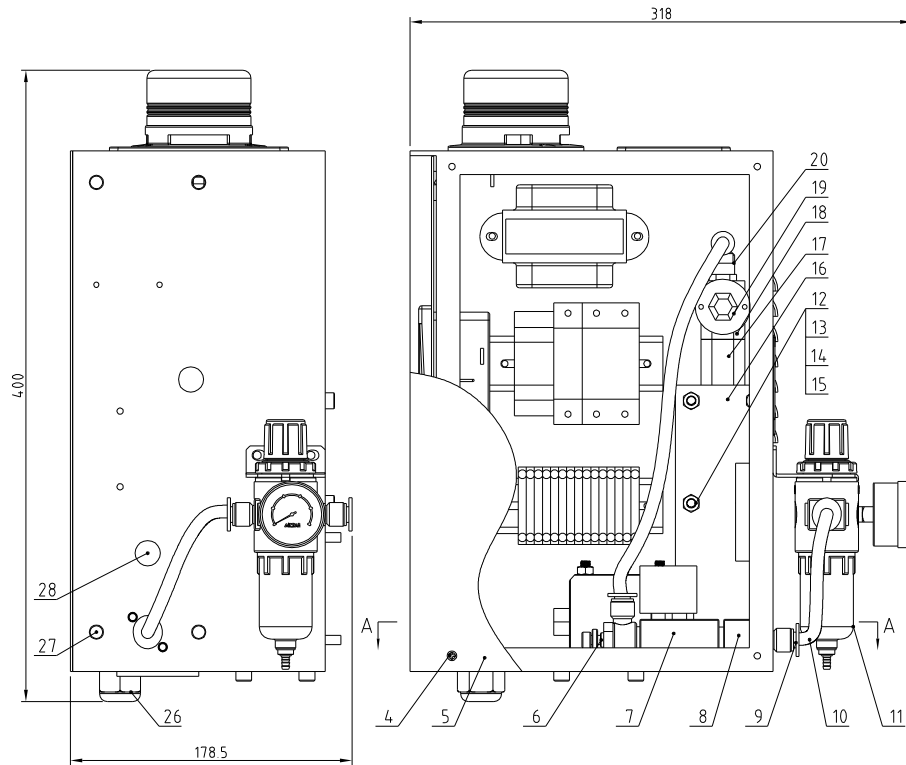

28	YR30001600000	Reserved hole plug for control box φ16 HP-16	2
27	YW61081000200	Inner hexagon cylinder head screw GB/T17116 M4×8-Longzine	4
26	YE67181500100	Copper solid plate cable connector (TIG-M) 1.5 for 15-4 cable Brass	1
25	BH11160000010	Connector SCAD-1U-B-09(SUS304) SUS304	1
24	YR20101800000	O-type seal ring 18 GB/T3652.1-1992(Silicone rubber) silicone rubber	2
23	SCAD-1U-B-10	Control box weldment	1
22	YE90052400300	Thermopipe 5x24-M4×15M SCAD-TD-A-37 Ver.01	1
21	BR90010800110	Heating box SCAD-1U-B-08 Drawing Version A1 (Heflon) PTFE	1
20	YW80081200000	L type screw connector PLB-04 1/2-#10A7-1.010 pcs/bag	1
19	YE15020400300	pressure switch LF207kPa	1
18	BH12111500110	Three way type SCAD-1U-B-11 drawing version A H588 H58	1
17	BH40108000050	Heater pipe SCAD-1U-B-06	1
16	BR90101000010	Heating box SCAD-1U-B-07 (Version A1) (Heflon) PTFE	1
15	YW69067700000	Cross recessed pan head screw GB/T 818 M4×7.0-zinc plating-white	8
14	YW64000600300	Hexagon nut GB/T6170 M6-Longzine	8
13	YW65006000100	Standard spring washer GB/T193 6-Longzine	8
12	YW66061300000	Flat washer A grade GB/T197 6-Longzine	8
11	YE30200020000	filter & pressure regulating valve AFR-2000	1
10	YR60000800000	PU air pipe φ8×φ6 black 100 M/roll	0.5
9	YW80081400000	Thread direct connector AFRB-02 1/4-#8AUC-1A(10) pcs/bag	3
8	BH12104500110	Vertical both to 5/8 external both SCAD-1U-B-02 Drawing version A H58	1
7	YE32382400000	Selected valve 3/8 type Rotapack 238C made VICTON-100 pcs/bag	1
6	YW80083800000	Adjustable air pipe connector ASB-3/8 (W) pieces/pack	1
5	SCAD-1U-B-03	Side plate SPCC15	1
4	YW67051000700	Cross socket pan head self-tapping lock screw GB6568 5×10-Longzine	6
3	SCAD-1U-B-02	Door plank SPCC12	1
2	YW06387300500	Two-way recessed hole both 02-041-2-020 brass hex pan screw M4×8	1
1	YW61041000100	cross socket counter sunk head screw GB6170 M4×8-Longzine	4

序号	代号	名称	材质	数量	备注
标题		SCAD-1U	图号 SCAD-1U-B-ALL		
设计		控制箱	比例		
校对					
审核			表面要求		
标记		更改前	更改后	更改人	日期
制图					
设计					
校对					
审核					
标记		更改前	更改后	更改人	日期

SHINI 信易电热机械股份有限公司
Shini Plastics Technologies, Inc.

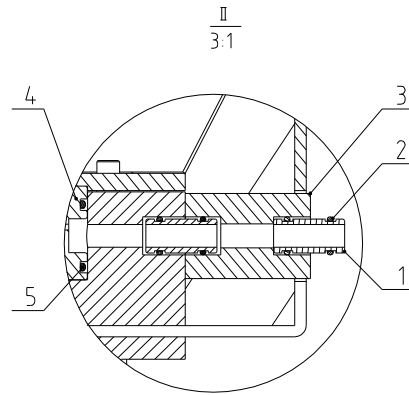
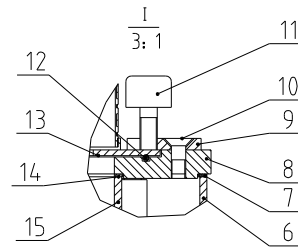
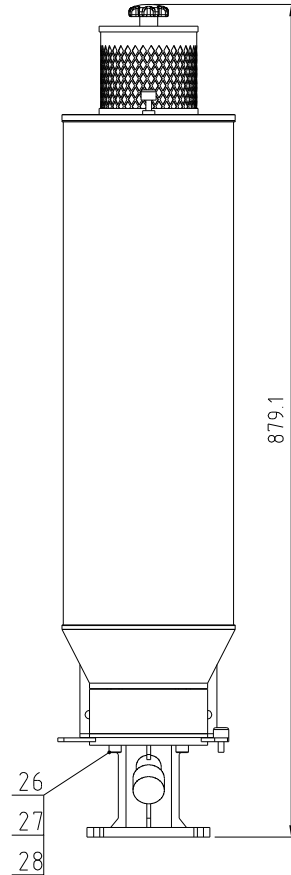
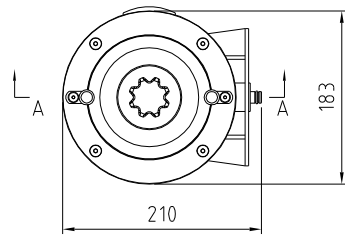
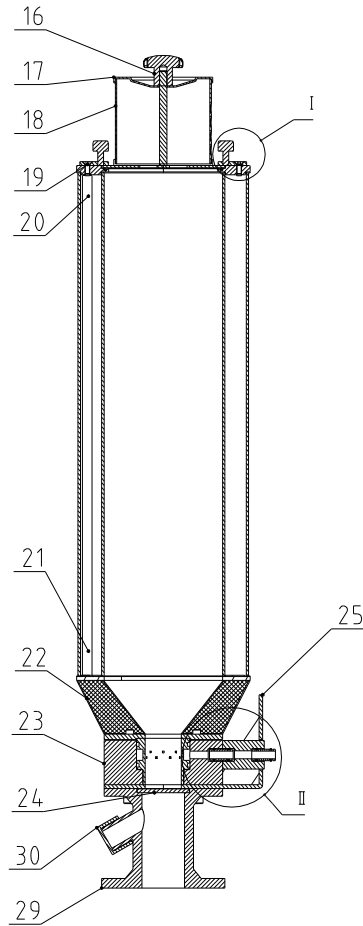

30	SCAD-1U-A-16	Discharging port cover	SUS201	1	
29	SCAD-1U-A-15	Base	SUS201	1	
28	YW66081900000	Flat washer A grade GB/T91.1 B		4	
27	YW65008000100	Standard spring washer GB/T93.8		4	
26	YW61088000000	Inner hex column head screw GB/T70.1 M5X8		4	
25	SCAD-6U-A-02	Control box fixed plate	SUS201	1	
24	SCAD-1U-A-14	Shut-off plate	SUS201	1	
23	SCAD-1U-A-13	Hopper base	PTFE	1	
22	SCAD-6U-A-01	Hopper	Assembly	1	
21	SCAD-6U-A-11	Upper flange 2 of hopper	SUS201	1	
20	SCAD-6U-A-08	Connecting rod	SUS304	4	
19	YW61062000500	Inner hexagon countersunk head screw GB/T70.3 M6X20		4	
18	YR50956000000	Filter ADC27		1	
17	SCAD-6U-A-09	Filter cover plate	SUS201	1	
16	YR400104.00000	Plastic star nut 1/4"		1	
15	YW70130125000	Glass pipe φ130Xφ125X531	Silicate	1	
14	SCAD-6U-A-06	Inner glass pipe fastener	Silica gel	2	
13	SCAD-6U-A-04	Filter fixed plate	SUS201	1	
12	YR20125300100	O type seal ring 119X3		1	
11	YW69616100000	Hand twisted screw M6X16X16		2	
10	YW61051000100	Inner hexagon countersunk head screw GB/T70.3 M5X10		2	
9	SCAD-6U-A-07	Filter pressure block	SUS201	2	
8	SCAD-6U-A-03	Hopper upper ring	ZL101	1	
7	SCAD-6U-A-10	Ext. glass pipe fastener	Silica gel	2	
6	YR40187300000	Transparent acrylic pipe φ80×φ72×1.5×30 SHM		1	
5	YR20535000000	O-type seal ring Outer diameter 50 • wire diameter 35		2	
4	SCAD-1U-A-06	Inner sleeve of hopper	SUS304	1	
3	SCAD-6U-A-05	Connecting insulation pipes	PTFE	1	
2	YR20101800000	O-type seal ring 10×18		4	
1	SCAD-1U-B-09	Connector	SUS201	2	

标记	更改前	更改后	更改人	日期	制图	设计	校对	审核	日期	版号	核准	标题	图号	比例	数量	备注
												SCAD-6U 干燥桶	SCAD-6U-A-ALL	1:1		
												SHINI 信易电热机械股份有限公司 Shini Plastics Technologies, Inc.		表面要求		
														物料号		

Compressed air flow	Drying heater power	Hopper capacity	Model Version
7m ³ /hr	600W	20L	Ver.C

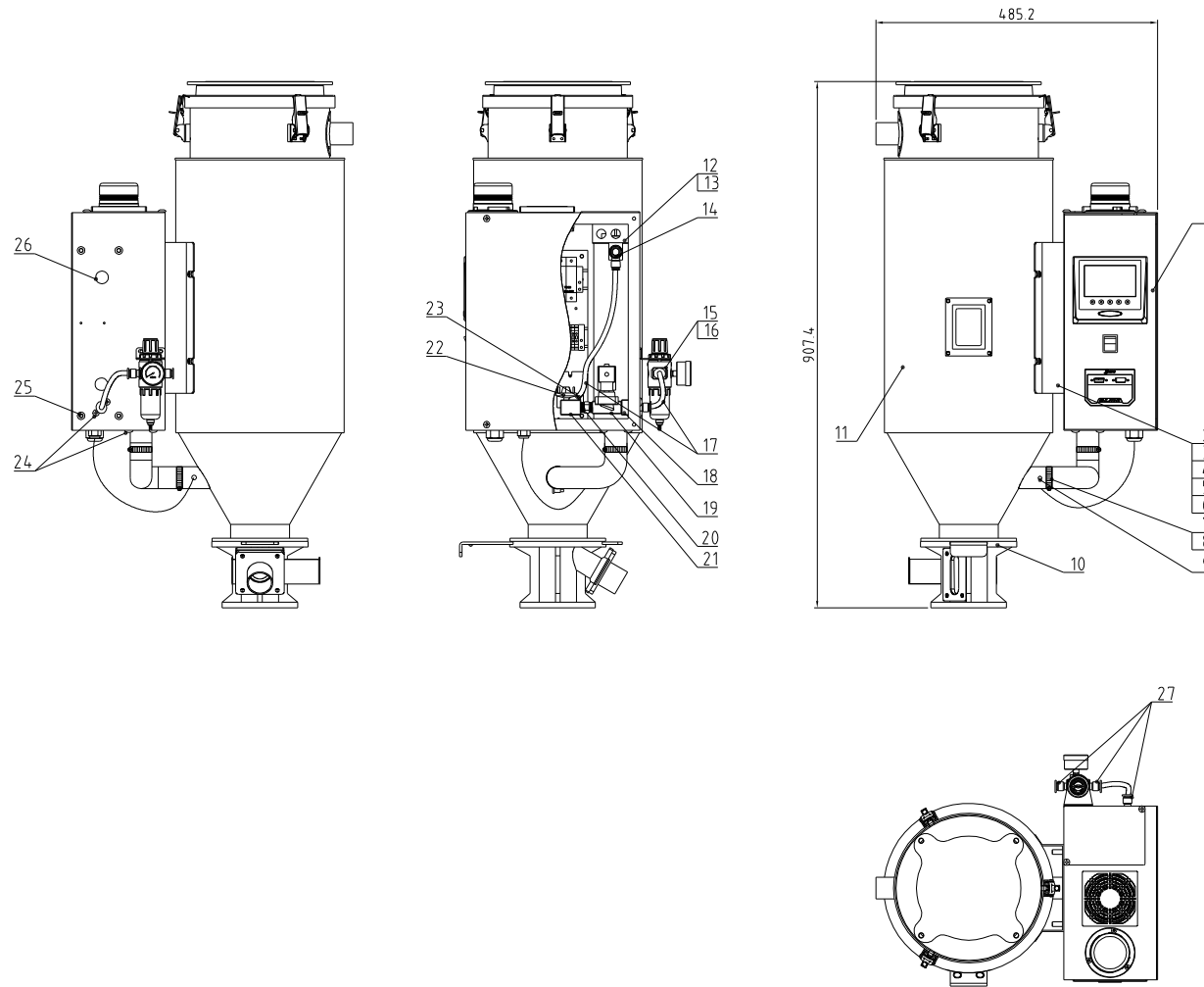

27	YW80081400000	Thread direct connector APC8-02 1/4"-8(Air TAC)		3	
26	YR30001600000	Control box reserved hole plug#16 HP-16		2	
25	YW60081200000	Inner hexagon cylindrical screw GB/T7701 M8x12-A2-70(SUS)		4	
24	YW67051000700	Cross socket pan head self-tapping lock screw GB6560 M5x10 Longzine		6	
23	YW80083800200	L thread connector APC8-03 3/8"-8(Air TAC)10pcs/pack	Assembly	1	
22	YE15020400300	Pressure switch LF20 4kPa	Assembly	1	
21	BH12126200010	Air pipe connector three way SCAD-12U-A-28(H62)	H62	1	
20	BH12030800110	Copper connector 3/8PTx3/8PT(S-07)		1	
19	YE32382400000	Solenoid valve 3/8 oil type (Kailing) 24VAC model VX02130-100J connection box	Assembly	1	
18	BH12104500110	1/8" internal depth to 3/8" external depth SCAD-20U-ALL-02 drawing version#	H58	1	
17	YR60000800000	PU air pipe ø8x6black 100M/roll			0.4 m
16	YW67040600600	Cross socket pan head self-tapping lock screw GB6560 M6x6 Longzine		2	
15	YE30200020000	Filter pressure regulating valve AFR-2000	Assembly	1	
14	YE30830000000	One-way throttle valve ASLB-03 3/8"-ø8 exhaust(Air TAC)	Assembly	1	
13	SCAD-20U-A-ALL	Heating case assembly	Assembly	1	
12	YR30000000200	Rubber plug SHD small SHD-20U-A-40(Butyl Rubber)(black)	Butyl Rubber	2	
11	SCAD-20U-B-ALL	Drying hopper assembly	Assembly	1	
10	BY10012003150	Standard base assembly HB-12(Ver.B)	Assembly	1	
9	YE90052400300	Thermocouple 5x24LxM8x15M(SCAD-12U-A-37 Ver.A)	Assembly	1	
8	YW72153600000	Heat resistant pipe 15" double layers red +3.6m	Assembly	1	0.4 m
7	YW02000200000	Steel wire hose F127-5(MM)(pipe clamp head/pipe clamp made of SUS201)	SUS201	2	
6	YW64080600000	Hexagonal nut GB/T6170 M8-Longzine		4	
5	YW65008000100	Standard spring washer GB/T93 8-Longzine		8	
4	YW66081600000	Flat washer A grade GB/T97 H8 4x16x1.6L Longzine		8	
3	YW60081600100	Hex bolt GB/T5781 M8x16-4 8-Longzine		4	
2	SCAD-20U-ALL-01	Control box fixed plate	SPCC2.0	1	
1	SCAD-20U-C-ALL	Control box	Assembly	1	

制图	版号	标题	SCAD-20U	图号	比例	数量
设计	核准	空压式干燥机			1:1	材质
校对	审核	SHINI 信易电热机械股份有限公司 Shini Plastics Technologies, Inc.			表面要求	物料号
标记	更改前		更改后	更改人	日期	审核

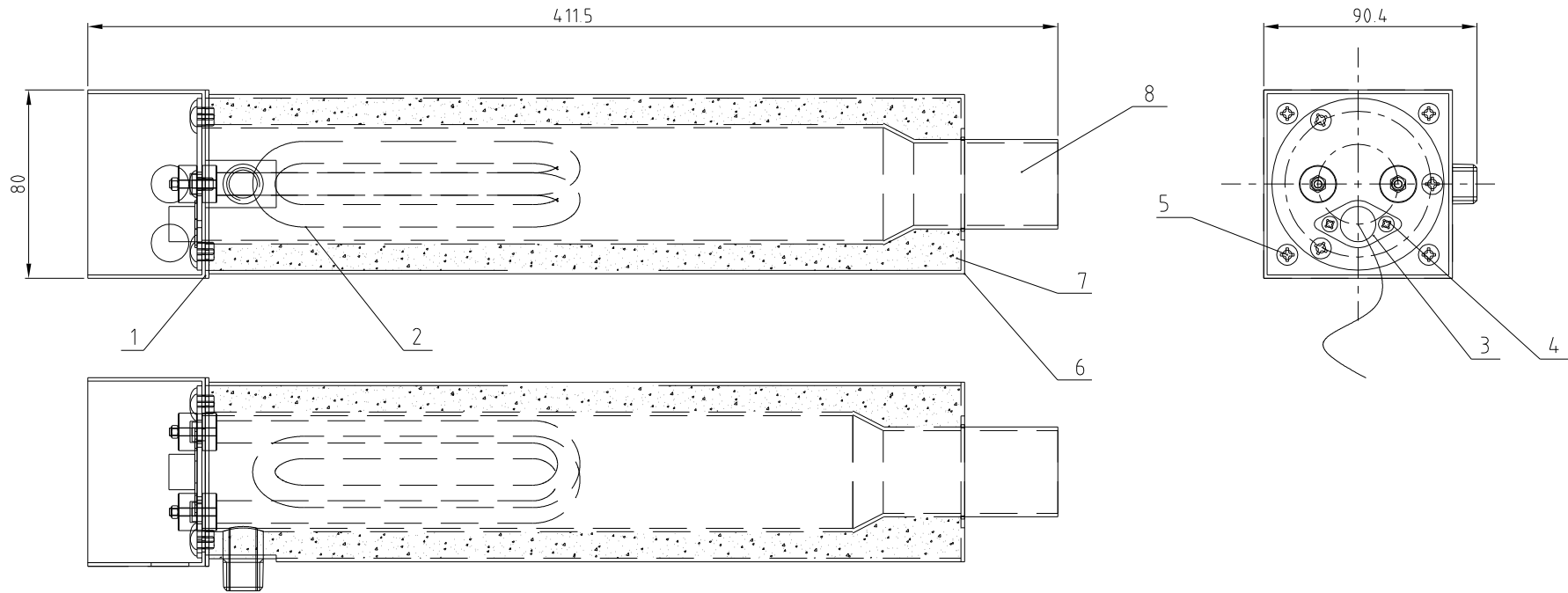

8	SCAD-20U-A-02	Heating case Inner case	Weldment	1	
7	YP60252000000	Aluminum platinum glass wool felt 25mm	Assembly	1	320mm×240mm
6	SCAD-20U-A-01	Heating case ext. case	SPCC1.5	1	
5	YW67041200600	Cross socket pan head self-tapping lock screw GB6560 M4×12 Longzine		7	
4	YW63030600000	Cross recessed pan head screw GB/T-823 M3×6-Longzine		2	
3	BE85013000550	Temp. protector K130 celsius (Length 0.5M) (heater constant open)	Assembly	1	
2	BH70402000110	Pipe heater SCAD-20U-A-0910.6KW/1φ 220V/Ver.01	Assembly	1	
1	SCAD-20U-A-04	Insulation Silica gel	Silica gel 3.0	1	
序号	代号	名称	材质	数量	备注

					制图	版号	标题	图号	比例	数量
					设计	核准	SCAD-20U 加热箱组件	SCAD-20U-A-ALL		材质
					校对		信易電熱機械股份有限公司 Shini Plastics Technologies, Inc.		表面要求	
标记	更改前	更改后	更改人	日期	审核	日期			物料号	

Compressed air flow	Drying heater power	Hopper capacity	Model Version
4.25m ³ /hr	600W	12L	Ver.C

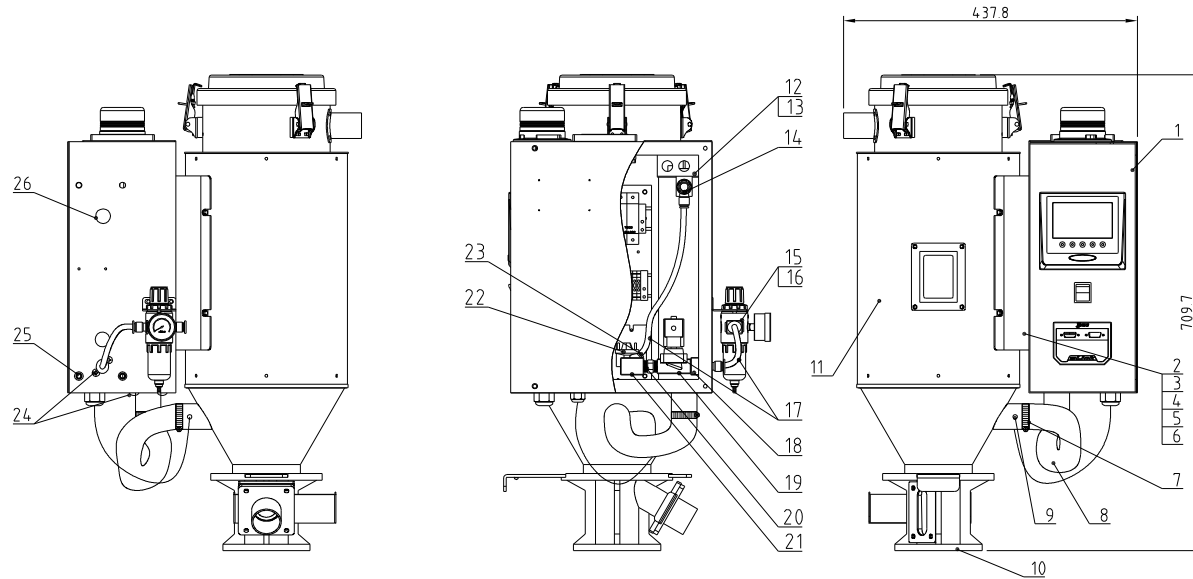

27	YW800814.00000	Thread direct connector APC8-02 1/4-#8(Air TAC)		3	
26	YR30001600000	Reserved hole plug for control box #16 HP-16		2	
25	YW60081200000	Inner hex column head screw GB/T701 M6x12-A2-70(SUS)		4	
24	YW67051000700	Cross socket pan head self-tapping lock screw GB5508 M5x10 Longzine		6	
23	YW80083800200	L thread connector AP18-03 3/8-#8(Air TAC)10 pcs/bag	Assembly	1	
22	YE150204.00300	Pressure switch LF20 4kPa	Assembly	1	
21	BH12126200010	Air pipe connector three way SCAD-12U-A-28(H62)	H62	1	
20	BH12030800110	Copper connector 3/8PT-3/8PT(S-07)		1	
19	YE323824.00000	Solenoid valve 3/8 oil type (Kai Ling) 24VAC model VXD2130-10J with connection box	Assembly	1	
18	BH12104500110	1/8 internal teeth to 3/8 external teeth SCAD-20U-ALL-02 drawing version 0	H58	1	
17	YR60000800000	PU air pipe φ8-φ6black 100M/roll		0.4m	
16	YW6704.0600600	Cross socket pan head self-tapping lock screw GB5508 M4x6 Longzine		2	
15	YE30200020000	Filter & pressure regulating valve AFR-2000	Assembly	1	
14	YE30830000000	One-way throttle valve ASL8-03 3/8-φ8 exhaust(AirTAC)	Assembly	1	
13	SCAD-20U-A-ALL	Heating case assembly	Assembly	1	
12	YR30000000200	Rubber plug SHD small SHD-20U-A-40(Butyl Rubber)(black)	Butyl Rubber	2	
11	SCAD-12U-B-ALL	Drying hopper assembly	Assembly	1	
10	BY10012003150	Standard base assembly HB-12(Ver B)	Assembly	1	
9	YE900524.00300	Thermocouple S-24L-MB415M (SCAD-12U-A-37 Ver A)	Assembly	1	
8	YW72153600000	Heat-resistant air pipe 15" double layers red-3mm	Assembly	0.4m	
7	YW02000200000	Steel wire hose 2"121-5999(pipe clamp head/pipe clamp made SUS201)	SUS201	2	
6	YW64.080600000	Hexagonal nut GB/T6170 M8-Longzine		4	
5	YW65008000100	Standard spring washer GB/T93 8-Longzine		8	
4	YW660081600000	Flat washer A grade GB/T193 18.4-16x16(L)ongzine		8	
3	YW60081600100	Hexagon bolt GB/T5781 M8x16-4.8-Longzine		4	
2	SCAD-12U-ALL-01	Control box fixed plate	SPCC2.0	1	
1	SCAD-20U-C-ALL	Control box	Assembly	1	Borrowed

序号 代号 名称 材料 数量 备注

					制图	版号	
					设计	核准	
					校对	审核	
标记	更改前	更改后	更改人	日期	审核	日期	

标题	SCAD-12U	图号		比例	数量
	空压式干燥机			1:1	材质
				表面要求	
				物料号	



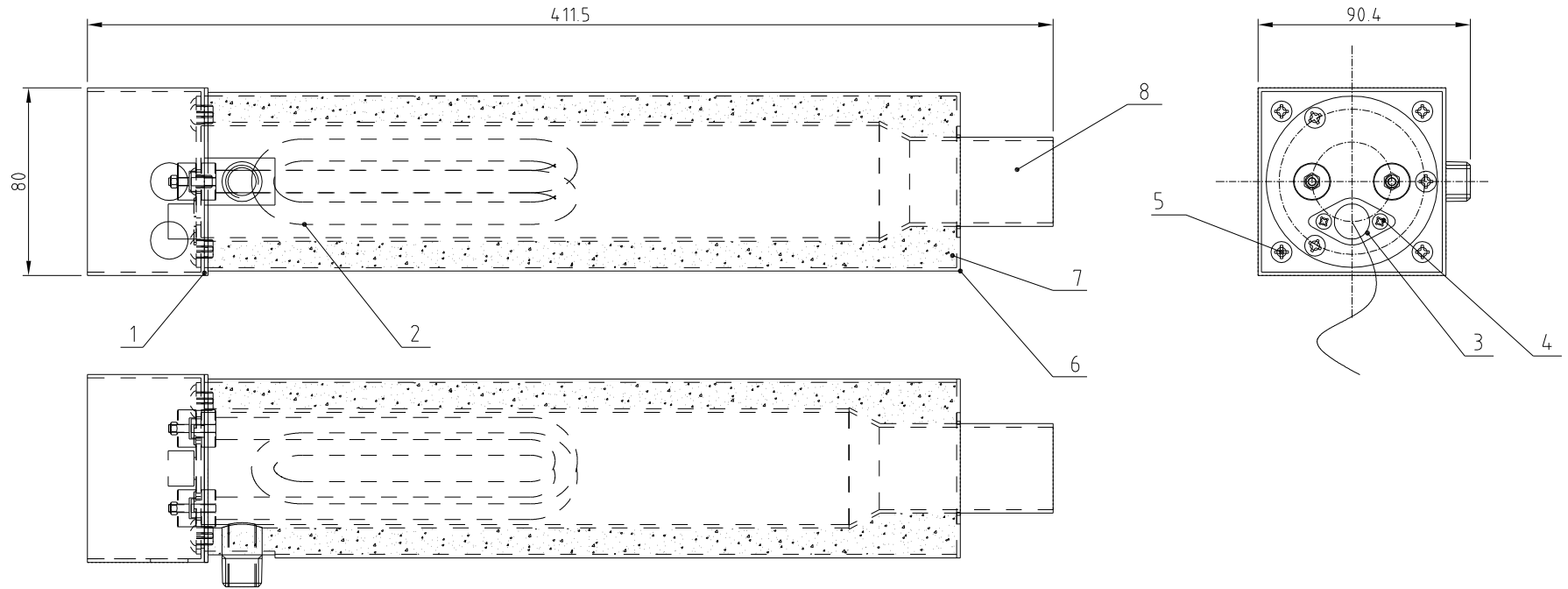

8	SCAD-20U-A-02	Heating case Inner case	Weldment	1	
7	YP60252000000	Aluminum platinum glass wool felt 25mm	Assembly	1	320mm×240mm
6	SCAD-20U-A-01	Heating case ext. case	SPCC1.5	1	
5	YW67041200600	Cross socket pan head self-tapping lock screw GB6550 M4×12 Longzine		7	
4	YW63030600000	Cross recessed pan head screw GB/T-823 M3×6-Longzine		2	
3	BE85013000550	Temp. protector K130 celsius (Length 0.5M) (heater constant open)	Assembly	1	
2	BH70402000110	Pipe heater SCAD-20U-A-0910 6KW/1φ 220V(Ver.0)	Assembly	1	
1	SCAD-20U-A-04	Insulation Silica gel	Silica gel 3.0	1	
序号	代号	名称	材质	数量	备注

					制图	版号	标题	图号	比例	数量
					设计	核准	SCAD-20U 加热箱组件	SCAD-20U-A-ALL		材质
					校对		信易電熱機械股份有限公司 Shini Plastics Technologies, Inc.	表面要求		
标记	更改前	更改后	更改人	日期	审核	日期		物料号		

Compressed air flow	Drying heater power	Hopper capacity	Model version
12m ³ /hr	600W	12L	Ver.C

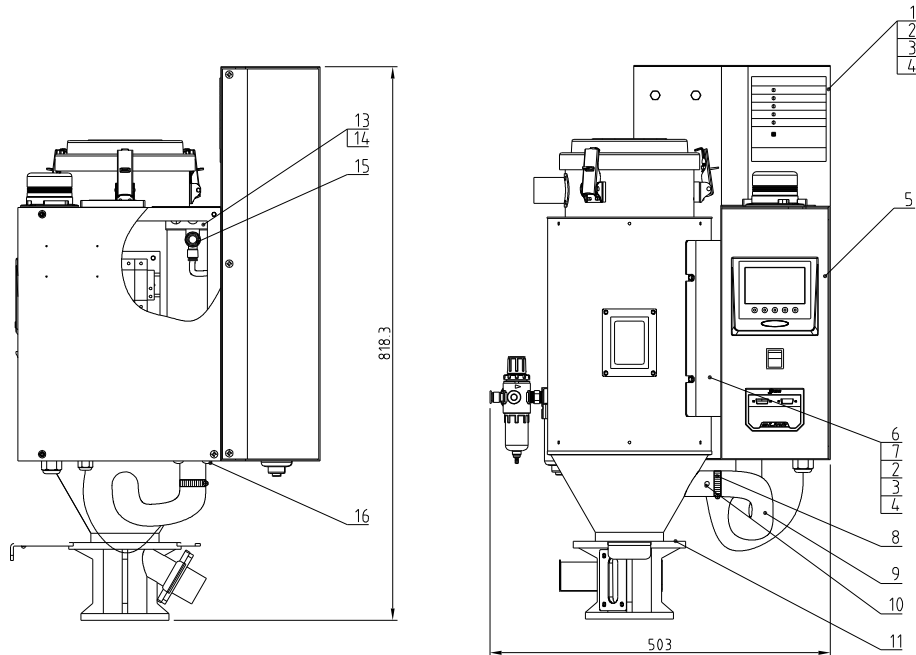

16	YW67051000700	Cross socket pan head self-lapping lock screw GB6500 M5x10 Longzine		4	
15	YE30830000000	One-way throttle valve AS18-03 3/8-g8 Exhaust(Air TAC)	Assembly	1	
14	SCAD-20U-A-ALL	Heating case assembly	Assembly	1	Borrowed
13	YR30000000200	Rubber plug SHD small SHD-20U-A-40 (Butyl Rubber)(black)	Butyl Rubber	2	
12	SCAD-12U-A-ALL	Drying hopper assembly	Assembly	1	
11	BY10012003150	Standard base assembly HB-12(Ver.B)	Assembly	1	
10	YE90052400300	Thermocouple 5x24L-M8x15M (SCAD-12U-A-37 Ver.A)	Assembly	1	
9	YW72153600000	Heat-resistant air pipe 15' double layers res-3.0H	Assembly	1	0.4m
8	YW02000200000	Stainless steel pipe clamp 2"07-5900(ope clamp head pipe clamp made of SUS201)	SUS201	2	
7	YW64080600000	Hexagonal nut GB/T6170 M8-Longzine		4	
6	SCAD-12U-ALL-01	Control box fixed plate	SPCC2.0	1	
5	SCAD-20U-C-ALL	Control box	Assembly	1	Borrowed
4	YW65008000100	Standard spring washer GB/T93 8-Longzine		12	
3	YW66081600000	Flat washer A grade GB/T97.18 4x16-16L-longzine		12	
2	YW60081600100	Hexagon bolt GB/T5781 M8x16-4.8-Longzine		8	
1	SCAD-20U-HD-A-ALL	Dehumidifier assembly	Assembly	1	Borrowed
序号	代号	名称	材料	数量	备注

				制图	版号	标题	SCAD-12U-HD	图号	比例	数量
				设计	核准	空压式干燥机				材质
				校对			信易电热机械股份有限公司		表面要求	
标记	更改前	更改后	更改人	日期	审核		日期	Shini Plastics Technologies, Inc.		物料号

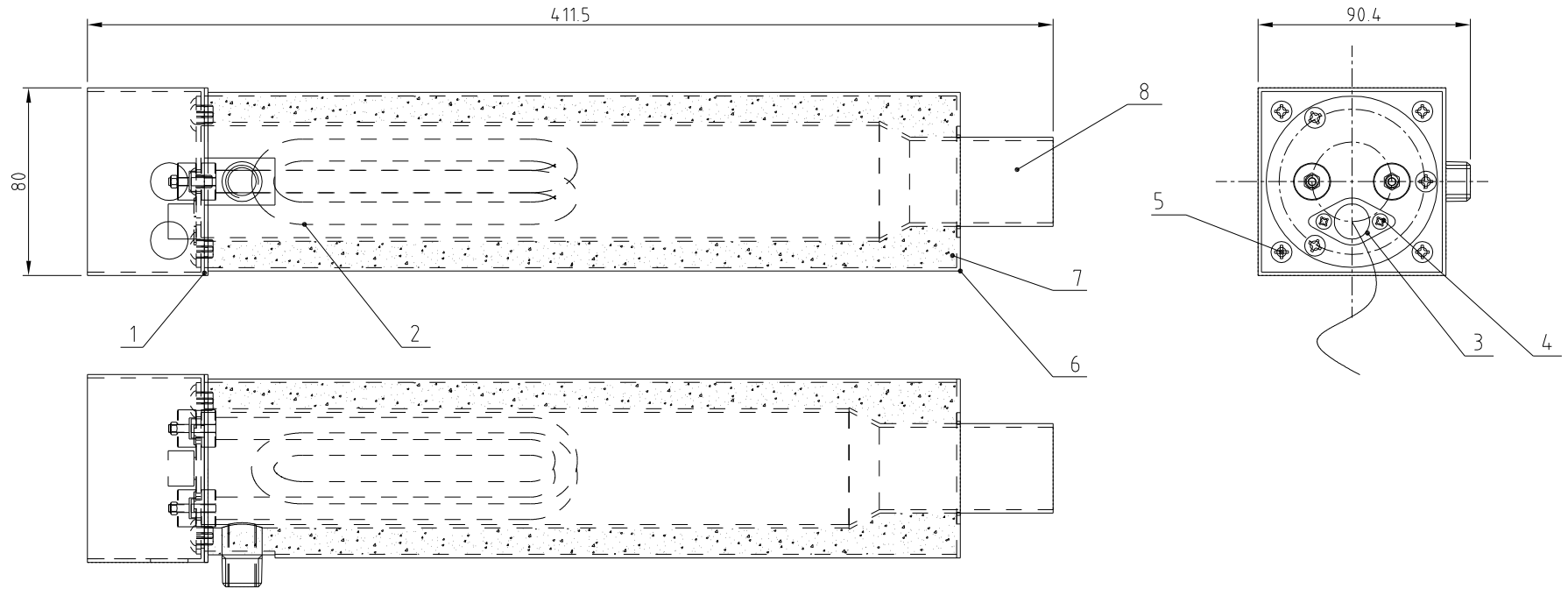

8	SCAD-20U-A-02	Heating case Inner box	Weldment	1	
7	YP60252000000	Aluminum platinum glass wool felt 25mm	Assembly	1	320mm×240mm
6	SCAD-20U-A-01	Heating case ext. box	SPCC1.5	1	
5	YW67041200600	Cross socket pan head self-tapping lock screw GB6560 M4×12 Longzine		7	
4	YW63030600000	Cross recessed pan head screw GB/T-823 M3×6-Longzine		2	
3	BE85013000550	Temp. protector K130 celsius(Length: 0.5M)(heater constant open)	Assembly	1	
2	BH70402000110	Pipe heater SCAD-20U-A-0910 6KW/1/φ 220V/Ver 01	Assembly	1	
1	SCAD-20U-A-04	Insulation Silica gel	Silica gel 3.0	1	
序号	代号	名称	材质	数量	备注

					制图	版号	标题	图号	比例	数量
					设计	核准	SCAD-20U 加热箱组件	SCAD-20U-A-ALL		材质
					校对		信易電熱機械股份有限公司 Shini Plastics Technologies, Inc.	表面要求		
标记	更改前	更改后	更改人	日期	审核	日期		物料号		

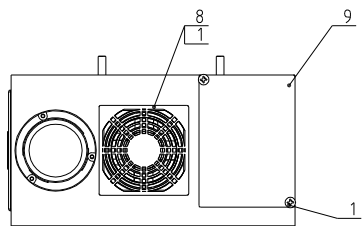
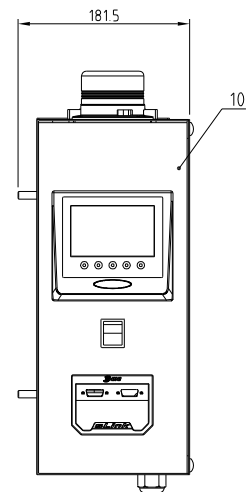
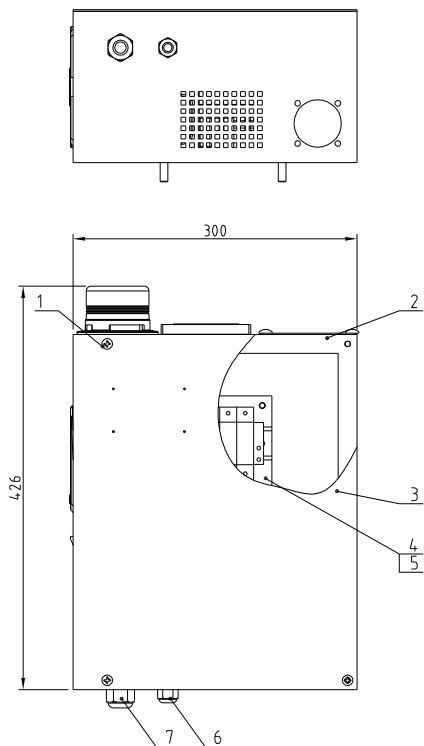

10	SCAD-20U-C-03	Control board	SPCC12	1	
9	SCAD-20U-C-05	Heating case cover	SPCC15	1	
8	YM60922500100	Exhaust fan - plastic air net 9225A1220V/240VAC50/60Hz	Assembly	1	
7	YE67181500100	Copper-nickel-plated cable joint 1.15-M8x511-3C for Cable	Assembly	1	
6	YE6700094.0000	Cable lock head PG9	Assembly	1	
5	YW64.000500000	Hexagon nut M5 anti-loose		4	
4	SCAD-20U-C-04	Electrical component installation plate	SECC15	1	
3	SCAD-20U-C-02	Control box door	SPCC15	1	
2	SCAD-20U-C-01	Control box body	SPCC15	1	
1	YW67051000700	Cross socket pan head self-lapping lock screw GB6560 M5x10 Longzine		14	
序号	代号	名称	材料	数量	备注

					制图	版号	标题	图号	比例	数量
					设计	核准	SCAD-20U	SCAD-20U-C-ALL		材质
					校对		控制箱			表面要求
标记	更改前	更改后	更改人	日期	审核	日期	信易電熱機械股份有限公司 Shini Plastics Technologies, Inc.		物料号	

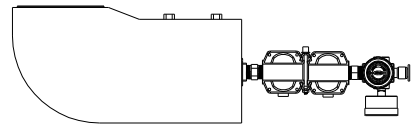
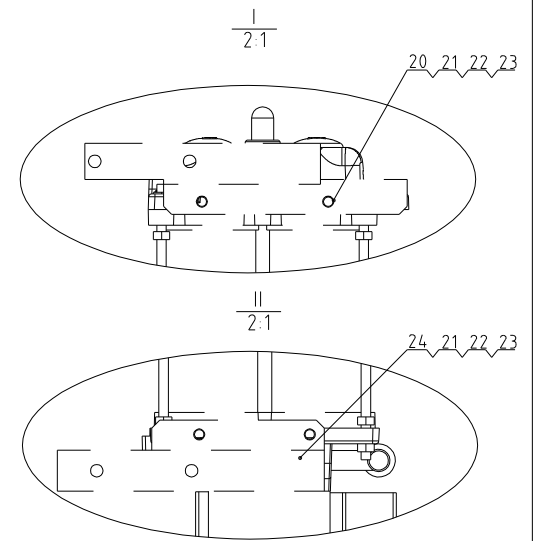
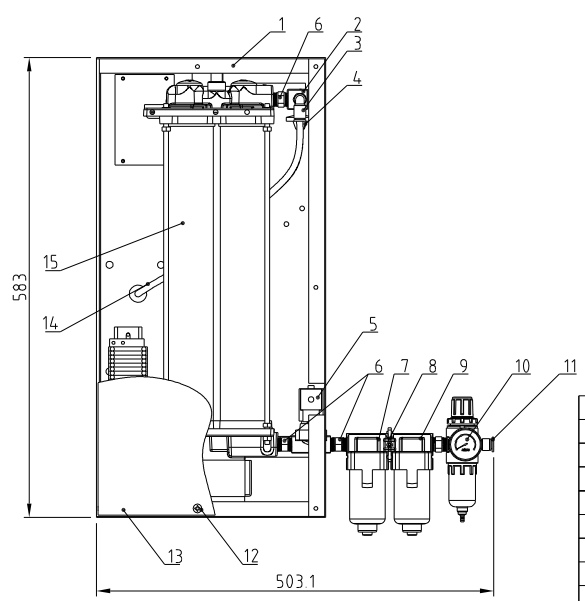
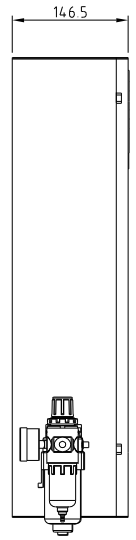
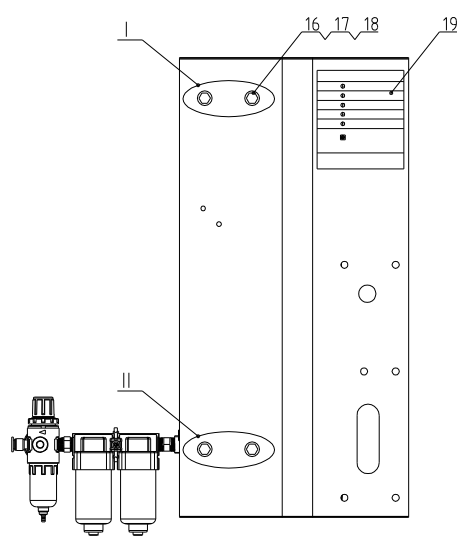

25	BH120104.00310	Copper connector 1/4T×3/8T(S-50)	H58	1	
24	SCAD-20U-HD-A-05	Lower fixed plate	SPCC3.0	1	
23	YW66061300000	Flat washer A grade GB/T9711.6-Longzine		4	
22	YW65006000100	Standard spring washer GB/T9316-Longzine		4	
21	YW61061200000	Inner hex column head screw GB/T701 M6x12-12.9-Longzine		4	
20	SCAD-20U-HD-A-04	Upper fixed plate	SPCC3.0	1	
19	YE80011800000	Heatless operation panel		1	
18	YW66081600000	Flat washer A grade GB/T9711.6-Longzine		4	
17	YW65008000100	Standard spring washer GB/T9316-Longzine		4	
16	YW60081600000	Hexagon bolt GB/T5783 M8x16-12.9-Longzine		4	
15	BY90200200150	Heatless regen air dryer 0206/SCAD-20U-HD-A-02	Assembly	1	
14	YR60000800000	PU air pipe φ8×φ6 black 100M/roll		0.4m	
13	SCAD-20U-HD-A-03	Dehumidifier fixed box plate	SPCC1.5	1	
12	YW67051000700	Cross socket pan head self-tapping lock screw GB6560 M5×10 Longzine		8	
11	YW800814.000000	Thread direct connector APCB-02 1/4-0.8(AirTAC)10 pcs/bag		1	
10	YE30200020000	Filter pressure regulating valve AFR-2000	Assembly	1	
9	YR50300300700	Oil mist separator AFM30-03D-A(SMC)	Assembly	1	
8	YW09030001500	insulated plate XIY300-A(SMC)	Assembly	1	
7	YR50300300600	Oil mist separator AFD30-03D-A(SMC)	Assembly	1	
6	BH12030800110	Copper connector 3/8PT×3/8PT(S-07)		3	
5	YE323824.000000	Solenoid valve 3/8 on type (Kaling)24VAC model VXD2130-100J with connection box	Assembly	1	
4	YE150204.003000	Pressure switch LF20 4kPa	Assembly	1	
3	YW800083800200	L thread connector APLB-03 3/8-0.8(AirTAC)10 pcs/pack	Assembly	1	
2	BH12126200010	Air pipe connector three way SCAD-12U-A-28H402	H62	1	
1	SCAD-20U-HD-A-01	Dehumidifier fixed case	SPCC1.5	1	

序号	代号	名称	材料	数量	备注
		标题 SCAD-20U-HD 除湿机组件	图号 SCAD-20U-HD-A-ALL	比例	数量
				表面要求	材质
标记	更改前	更改后	更改人	日期	审核
				日期	



Compressed air flow	Drying heater power	Hopper capacity	Model Version
14m ³ /hr	1200W	40L	Ver.B

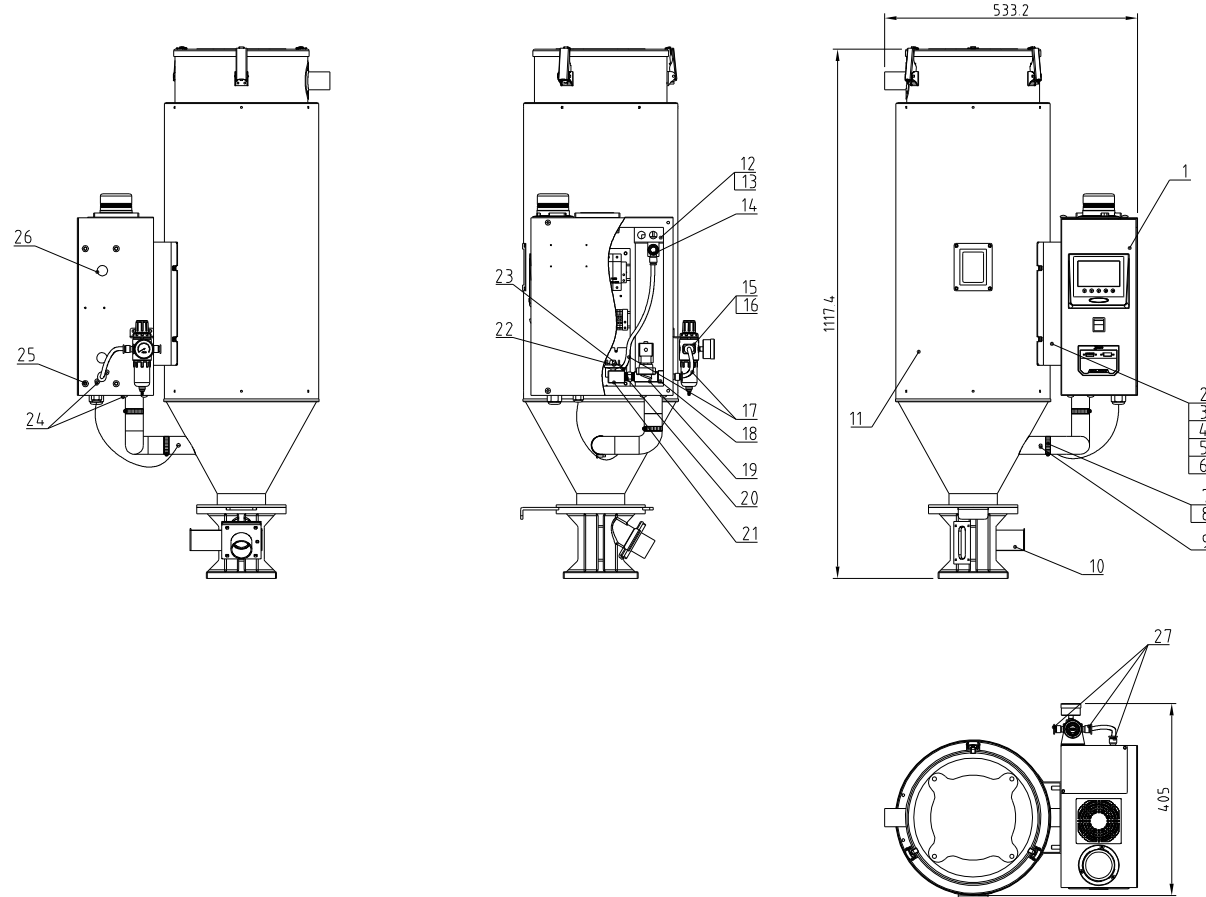

27	YW80081400000	Thread direct connector AP68-02 1/4-ø8(Air TAC)		3	
26	YR30001600000	Control box reserved hole plug#16 HP-16		2	
25	YW60081200000	Inner hexagon cylindrical screw GB/T7011 M8x12-A2-70(SUS)		4	
24	YW67051000700	Cross socket pan head self-tapping lock screw GB550 M5x10-Longzine		6	
23	YW80083800200	L thread connector AP68-03 3/8-ø8(Air TAC)10pcs/pack	组件	1	
22	YE15020400300	Pressure switch LF20 4kPa	组件	1	
21	BH12126200010	Air pipe connector three way SCAD-12U-A-28(H62)	H62	1	
20	BH12030800110	Copper connector 3/8PT*3/8PT(S-07)		1	
19	YE32382400000	Solenoid valve 3/8 oil type (Kaiting) 24VAC model VX02130-100J connection box	组件	1	
18	BH12104500110	1/8 internal teeth to 3/8 external teeth SCAD-100-AL1-02 6xamp version 8	H58	1	
17	YR60000800000	PU air pipe ø8-ø6black 16M/roll		0.4米	
16	YW67040600600	Cross socket pan head self-tapping lock screw GB550 M4x8 Longzine		2	
15	YE30200020000	Filter pressure regulating valve AFR-2000	组件	1	
14	YE30830000000	One-way throttle valve ASL8-03 3/8-ø8 exhaust(Air TAC)	组件	1	
13	SCAD-40U-A-ALL	Heating case assembly	组件	1	
12	YR30000000200	Rubber plug SHD small SHD-2WU-A-40(Butyl Rubber)(black)	丁基橡胶	2	
11	SCAD-40U-B-ALL	Drying hopper assembly	组件	1	
10	BY10050003150	Standard base HB-50	组件	1	
9	YE90052400300	Thermocouple 5x24LxMBx15M ISCAD-12U-A-37 (Ver.A)	组件	1	
8	YW72153600000	Heat resistant pipe 15" double layers red x3.6m	组件	1	0.4米
7	YW02000200000	Steel wire hose 2"127-5MM(1/2)pipe clamp head/pipe clamp made of SUS201	SUS201	2	
6	YW64080600000	Hexagonal nut GB/T6170 M8-Longzine		4	
5	YW65008000100	Standard spring washer GB/T93 8-Longzine		8	
4	YW66081600000	Flat washer A grade GB/T97 MB 4-16-1.6L,Longzine		8	
3	YW60081600100	Hex bolt GB/T5781 M8x16-4.8-Longzine		4	
2	SCAD-40U-ALL-02	Control box fixed plate	SPCC2.0	1	
1	SCAD-20U-C-ALL	Control box	组件	1	借用

序号	代号	名称	材料	数量	备注
		标题 SCAD-40U 空压式干燥机	图号	比例	数量
		信易电热机械股份有限公司 Shini Plastics Technologies, Inc.	表面要求 物料号	材质	
制图	版号				
设计	核准				
校对	日期				
审核	日期				
标记	更改前	更改后	更改人	日期	审核

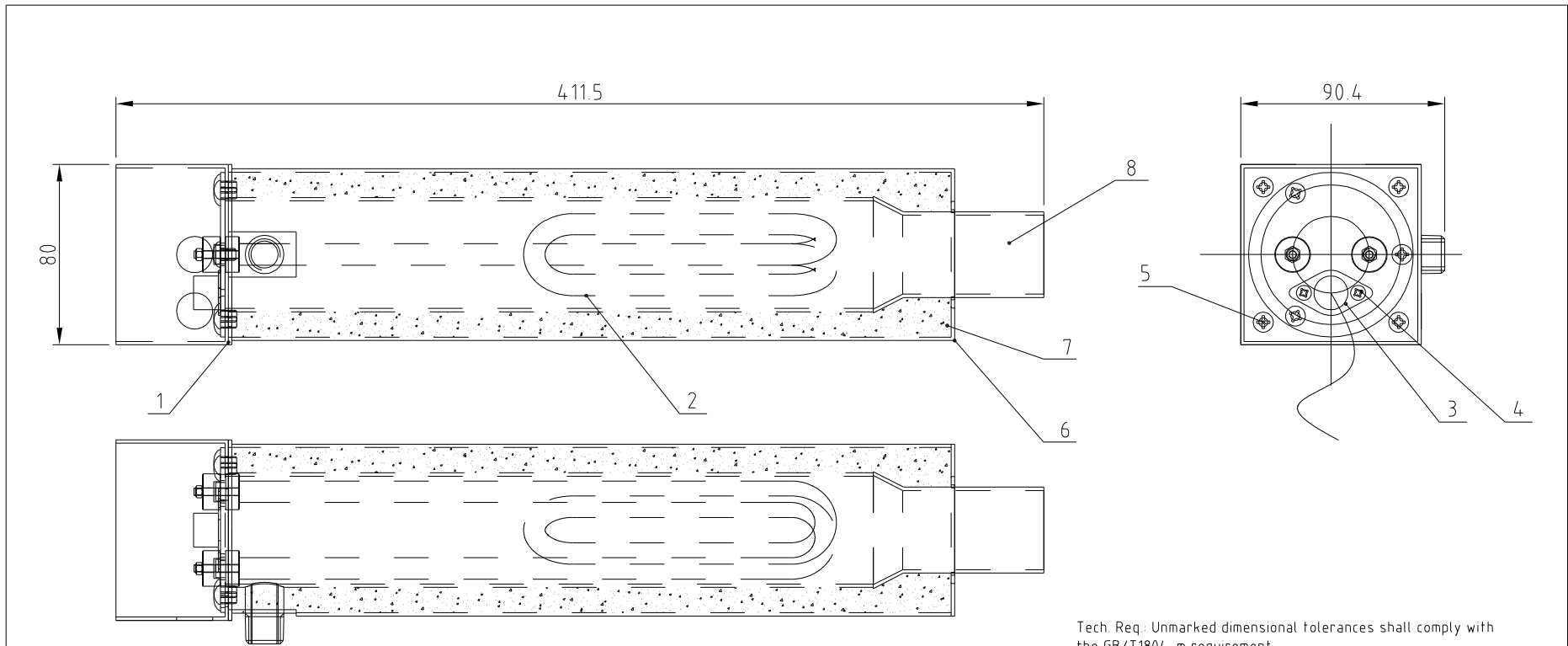

Tech. Req.: Unmarked dimensional tolerances shall comply with the GB/T1804-m requirement.

8	SCAD-20U-A-02	Heating case Inner box	Weldment	1	Assembly
7	YP60252000000	Aluminum platinum glass wool felt 25mm	Assembly	1	320mm×240mm
6	SCAD-20U-A-01	Heating case ext box	SPCC1.5	1	Assembly
5	YW67041200600	Cross socket pan head self-lapping lock screw GB6560 M4×12 Longzine		7	
4	YW63030600000	Cross recessed pan head screw GB/T-823 M3x6-Longzine		2	
3	BE85013000550	Temp. protector K130 celsius(Length: 0.5M)(heater constant open)	Assembly	1	
2	BH70400100150	Pipe heater SCAD-40U-A-0112kW/1φ 220V/II Ver. 0	Assembly	1	
1	SCAD-20U-A-04	Insulation Silica gel	Silica gel 3.0	1	Assembly
序号	代号	名称	材质	数量	备注

					制图	黄学明	版号	0	标题	SCAD-40U 加热箱组件	图号	SCAD-40U-A-ALL	比例	1:2.5	数量	1
					设计	黄学明	核 准						表面要求	物料号		
					校对											
标记	更改前	更改后	更改人	日期	审核		日期	20221125	 信易电热机械股份有限公司 Shini Plastics Technologies, Inc.							

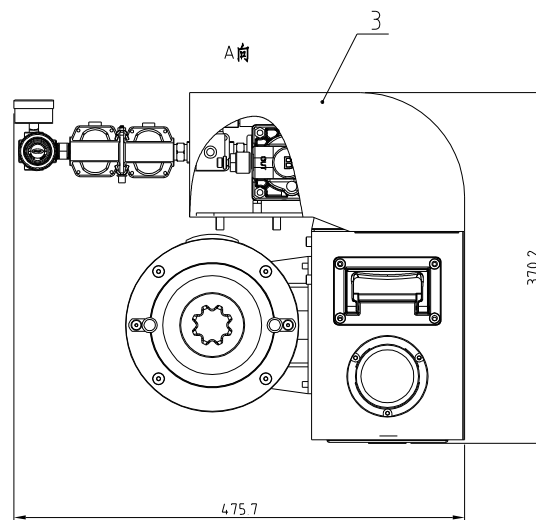
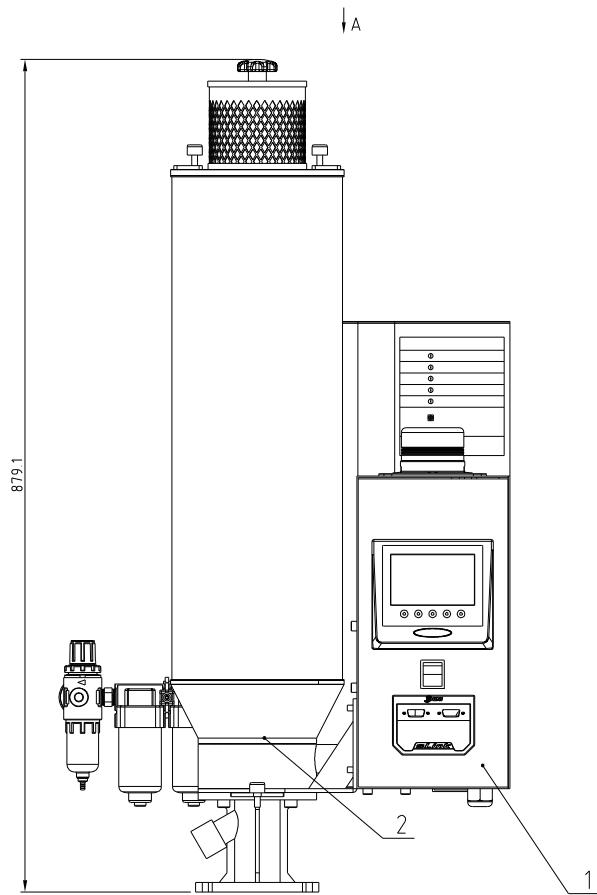

Tech. Req:
 1.Compressed air flow>100L/min;
 2.Power:1PH230VAC^{50/60}Hz;
 3.Before assembly, it's necessary to clean it thoroughly without scratch on the surface;
 4.The parameters are as below:
 Machine total power:300W
 Drying hopper capacity: 6L

3	SCAD-6U-A-ALL	Drying hopper	Component	1	
2	SCAD-3U-HD-B-ALL	Dehumidifier assembly	Component	1	Borrowed
1	SCAD-3U-HD-A-ALL	Control box	Component	1	Borrowed
序号	代号	名称	材质	数量	备注

					制图	版号	0	标题	SCAD-6U-HD	图号	SCAD-6U-HD-ALL	比例	数量
					设计	核			空压式干燥机			⊕	材质
					校对	准		信易电热机械股份有限公司 Shini Plastics Technologies, Inc.				表面要求	
标记	更改前	更改后	更改人	日期	审核	日期							物料号

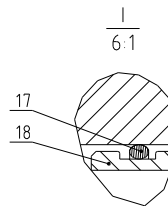
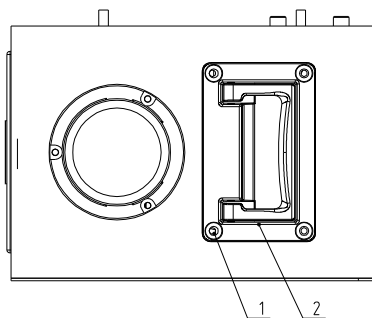
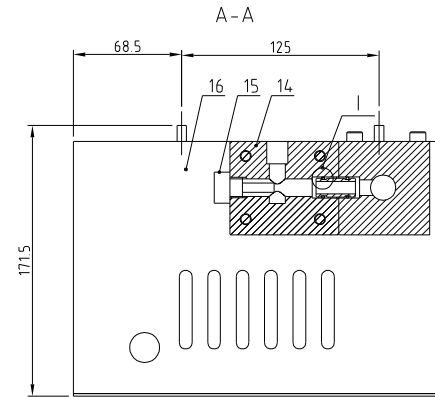
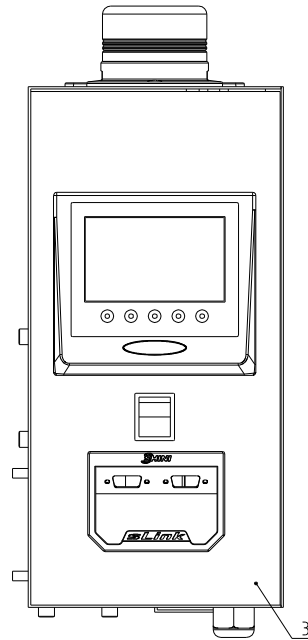
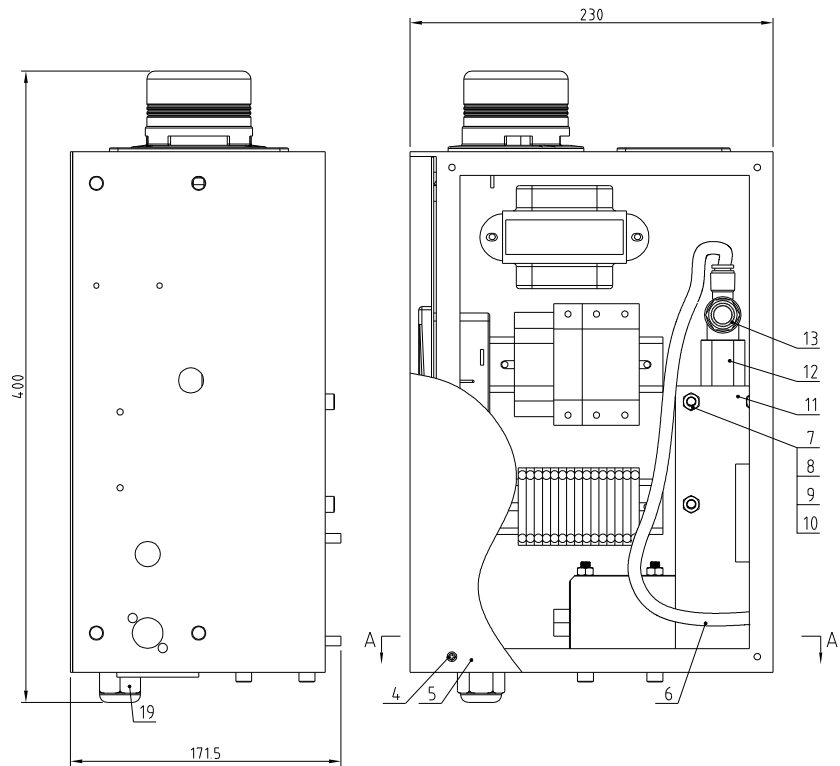

Tech Req:
Used when selecting -HD mode of the machine.

19	YE67181500100	Copper nickel plated cable connector 1/2"MH-15 for 15-8 cable SUS304	1	
18	BH11116000010	Connector SCAD-1U-B-09(SUS304) SUS304	1	
17	YR20101800000	O-type seal ring 8x18.6 GB/T3452.1-1992(Green rubber) gasket	4	
16	SCAD-1U-B-10	Control box	Weldment	1
15	YE90052400300	Thermocouple 5x24x150(SICAD-1U)-A-37 Ver A1	Assembly	1
14	BR90010800110	heating box 2 SCAD-1U-B-08(Teflon PTFE)Ver A pipe	Assembly	1
13	YW81120800000	Sealed flexible tap joint control valve P23-04 1/2" #15 for M3	Assembly	1
12	BH40108000050	Heater pipe SCAD-1U-B-06	Assembly	1
11	BR90101000010	heating box SCAD-1U-B-07(Ver A)(Teflon) PTFE	Assembly	1
10	YW69067700000	Cross recessed pan head screw GB/T 818 M6x10-zinc plating-white	8	
9	YW64000600300	Hexagon nut GB/T6170 M6-Longzine	8	
8	YW65006000100	Standard spring washer GB/T931.6-Longzine	8	
7	YW66061300000	Flat washer A grade GB/T971.6-Longzine	8	
6	YR60805000000	Air pipe M6x5mmx100(M)Air TAC(back)	PU	0.5
5	SCAD-1U-B-03	side plate	SPCC15	1
4	YW67051000700	Cross socket pan head self-tapping lock screw GB6568 5x10 Longzine	6	
3	SCAD-1U-B-02	Door plank	SPCC12	1
2	YW06387300500	Zinc alloy concealed handle 30x48.7x22.65 black/plate position NO-58	1	
1	YW61041000100	Cross socket counter sunk head screw GB6170 M6x10 Longzine	4	

序号	代号	名称	材质	数量	备注
		标题 SCAD-3U-HD	图号 SCAD-3U-HD-A-ALL	比例	数量
		控制箱			材质
		SHINI 信易电热机械股份有限公司	表面要求		
		Shini Plastics Technologies, Inc.	物料号		
制图		版号			
设计		核准			
校对		日期			
标记	更改前	更改后	更改人	日期	审核

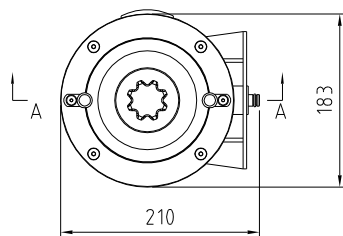
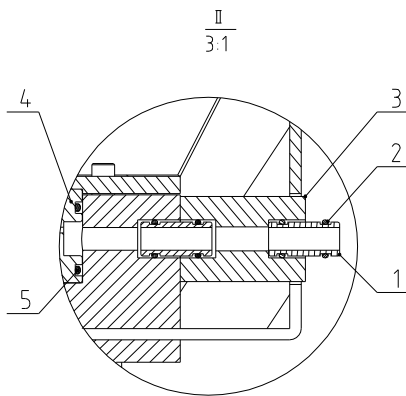
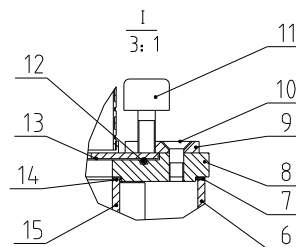
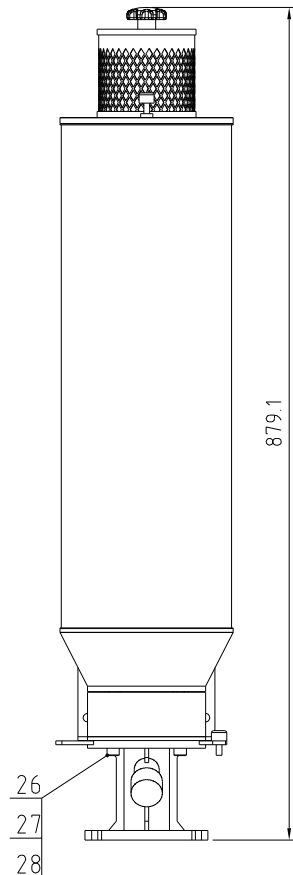
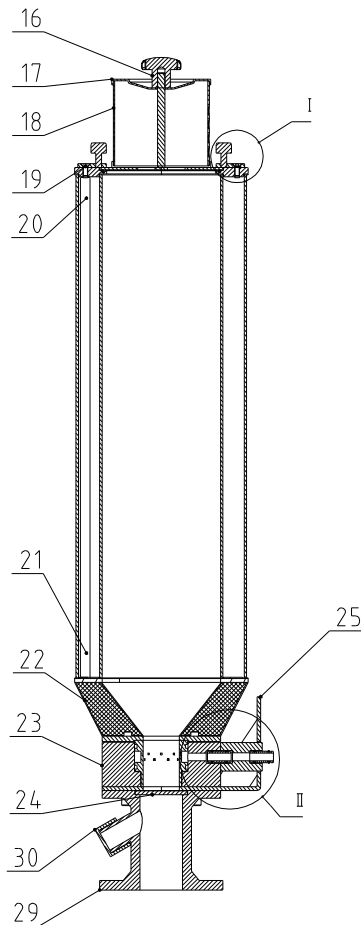

30	SCAD-1U-A-16	Discharge port cover	SUS201	1	
29	SCAD-1U-A-15	Base	SUS201	1	
28	YW66081900000	Flat washer A grade GB/T197.1.8		4	
27	YW65008000100	Standard spring washer GB/T193.8		4	
26	YW61088000000	Hexagon socket head cap screw GB/T170.3 M6x20		4	
25	SCAD-6U-A-02	Control box fixed plate	SUS201	1	
24	SCAD-1U-A-14	Shut-off plate	SUS201	1	
23	SCAD-1U-A-13	Hopper base	PTFE	1	
22	SCAD-6U-A-01	Hopper	Assembly	1	
21	SCAD-6U-A-11	Upper flange 2 of hopper	SUS201	1	
20	SCAD-6U-A-08	Connecting rod	SUS304	4	
19	YW61062000500	Inner hexagon countersunk head screw GB/T170.3 M6x20		4	
18	YR50956000000	Filter ADC27		1	
17	SCAD-6U-A-09	Filter cover plate	SUS201	1	
16	YR400104.00000	Plastic star nut black 1/4"		1	
15	YW70130125000	Glass pipe φ130×φ125×531	Silicate	1	
14	SCAD-6U-A-06	Inner glass pipe fastener	Silica gel	2	
13	SCAD-6U-A-04	Filter fixed plate	SUS201	1	
12	YR20125300100	O type seal ring 119X3		1	
11	YW69616100000	Hand twisted screw M6x16x16		2	
10	YW61051000100	Inner hexagon countersunk head screw GB/T170.3 M5x10		2	
9	SCAD-6U-A-07	Filter pressure block	SUS201	2	
8	SCAD-6U-A-03	Hopper upper ring	ZL101	1	
7	SCAD-6U-A-10	Ext. glass pipe fastener	Silica gel	2	
6	YR40187300000	Insulated pipe φ100×φ125×531		1	
5	YR20535000000	O type seal ring ext. dia. 39mm dia. 1.5		2	
4	SCAD-1U-A-06	Inner sleeve of hopper	SUS304	1	
3	SCAD-6U-A-05	Connecting insulation pipes	PTFE	1	
2	YR20101800000	O-type seal ring 10*1.8		4	
1	SCAD-1U-B-09	Connector	SUS201	2	

标记	更改前	更改后	更改人	日期	制图	设计	校对	制图日期	版号	核准	日期	标题	图号	比例	数量	备注
												SCAD-6U	SCAD-6U-A-ALL	1:1		
												干渠桶				
												SHINI 信易电热机械股份有限公司 Shini Plastics Technologies, Inc.				
														表面要求		
														物料号		

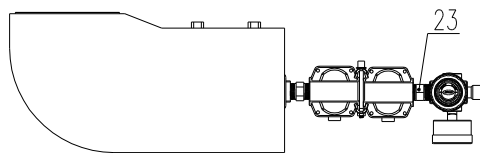
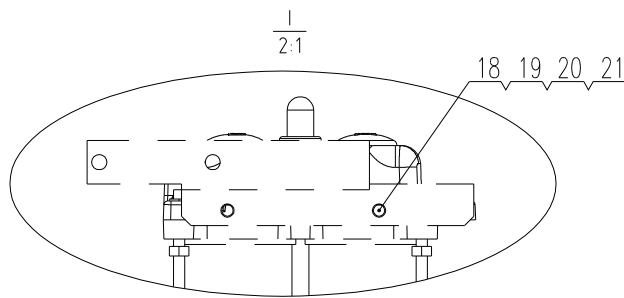
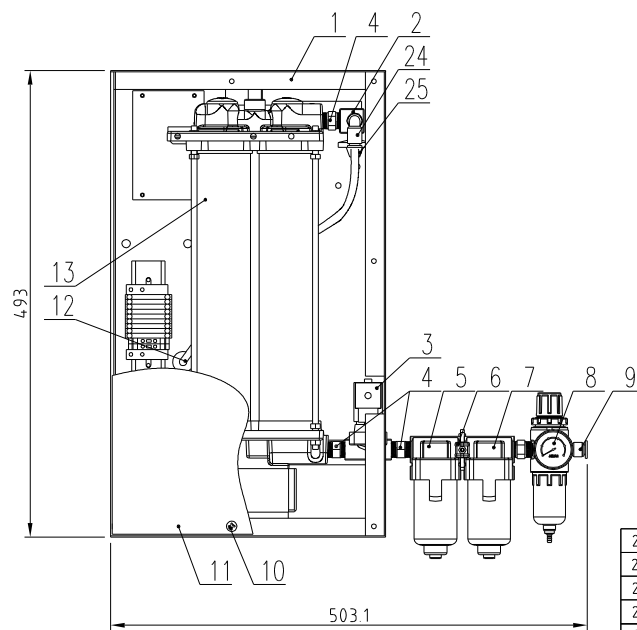
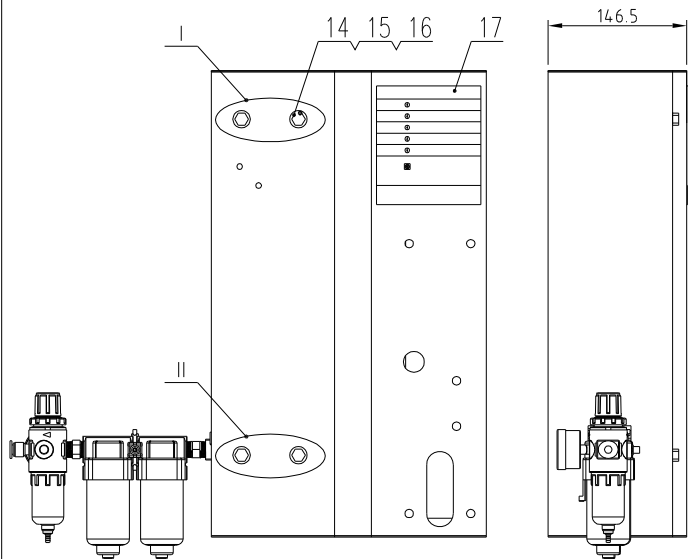

25	YE15020400300	Pressure switch LF20 4kPa	Assembly	1	
24	YW80083800200	L type screw connector APL8-03 3/8-#8/Air TAC10 pcs/bag	Assembly	1	
23	BH120104.00310	Copper connector 1/4T×3/8TIS-50	H58	1	
22	SCAD-20U-HD-A-05	Lower fixing plate	SPCC3.0	1	
21	YW66061300000	Flat washer A grade GB/T9711 6-Longzine		4	
20	YW65006000100	Standard spring washer GB/T93 6-Longzine		4	
19	YW61061200000	Hexagon socket head cap screw GB/T701 M6x12-12.9-Longzine		4	
18	SCAD-20U-HD-A-04	Upper fixing plate	SPCC3.0	1	
17	YE80011800000	Heatless operation panel		1	
16	YW66081600000	Flat washer A grade GB/T9711 8.4×16×1.6-Longzine		4	
15	YW65008000100	Standard spring washer GB/T93 8-Longzine		4	
14	YW60081600000	Hexagon bolt GB/T5783 M6x16-12.9-Longzine		4	
13	BY90010600150	Heatless regen. air dryer 0106/SCAD-3U-HD-B-02	Assembly	1	
12	YR60000800000	PU air pipe #8×#6 black 100M/roll		0.4M	
11	SCAD-3U-HD-B-03	Dehumidifier fixed box plate	SPCC1.5	1	
10	YW67051000700	Cross socket pan head self-tapping lock screw GB6560 M5×10-Longzine		8	
9	YW800814.00000	Thread direct connector APC8-02 1/4-#8/Air TAC10 pcs/bag		1	
8	YE30200020000	Filter pressure regulating valve AFR-2000	Assembly	1	
7	YR50300300700	Oil mist separator AFM30-03D-AISMCI	Assembly	1	
6	YW09030001500	Baffle plate IXIY300-A(ISMC)	Assembly	1	
5	YR50300300600	Oil mist separator AFD30-03D-AISMCI	Assembly	1	
4	BH12030800110	Copper connector 3/8PT×3/8PTIS-07		3	
3	YE323824.00000	Solenoid valve 3/8 oil type (Kalmig) 24VAC model VXD2130-100J with junction box	Assembly	1	
2	BH12126200010	Air pipe connector three way SCAD-12U-A-2BH62	H62	1	
1	SCAD-3U-HD-B-01	Dehumidifier fixed case	SPCC1.5	1	

标记	更改前	更改后	更改人	日期	制图	设计	校对	审核	版号	核准	日期	标题	图号	比例	数量	材质	表面要求	物料号
												SCAD-3U-HD	SCAD-3U-HD-B-ALL	1:1				
												除湿机组件						
												SHINI	信易电热机械股份有限公司 Shini Plastics Technologies, Inc.					

Compressed air flow	Drying heater power	Hopper capacity	Model Version
21m ³ /hr	1200W	40L	Ver.B

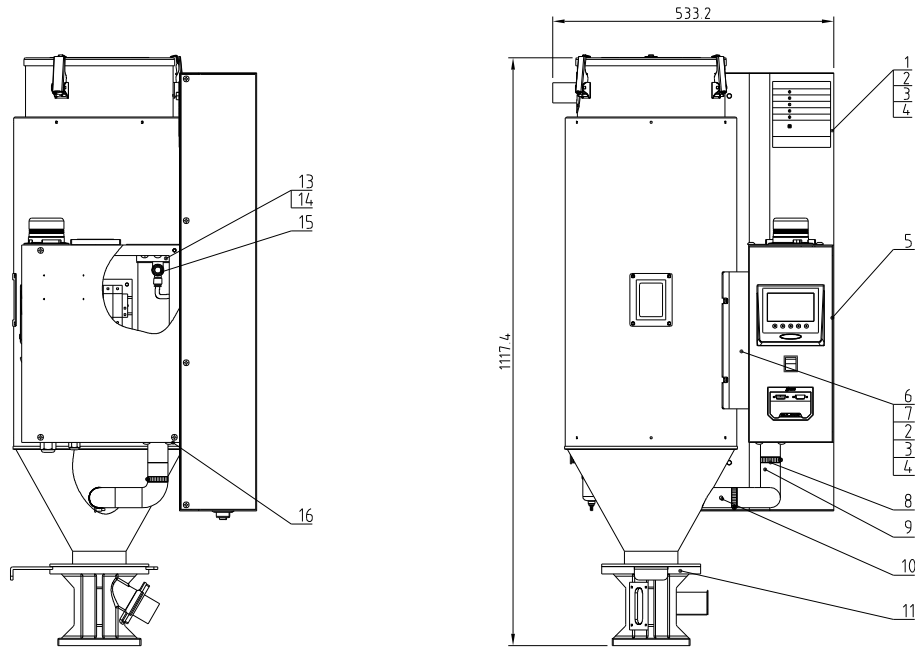

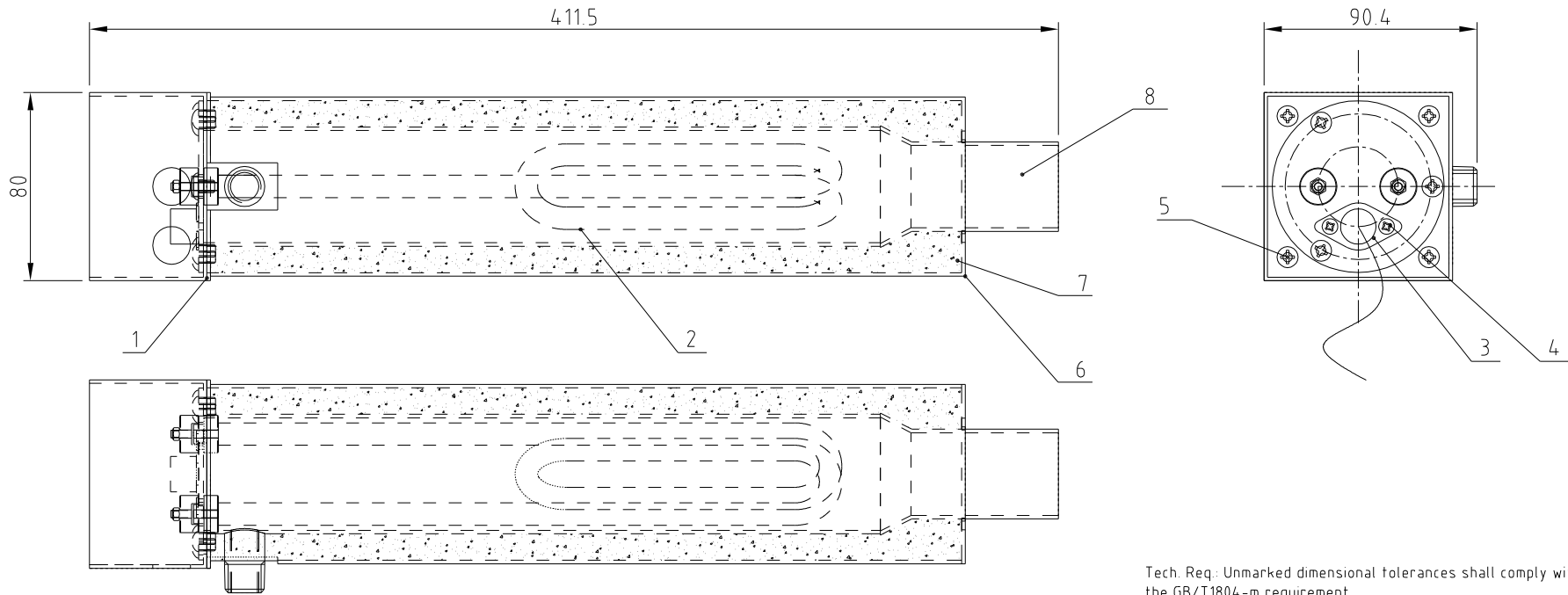

16	YW67051000700	Cross socket pan head self-lapping lock screw GB6560 M5×10 Longzinc		4	
15	YE30830000000	One-way throttle valve ASLB-03 3/8-g8exhaust(Air/FAC)	Assembly	1	
14	SCAD-40U-A-ALL	Heating case assembly	Assembly	1	
13	YR3000000200	Rubber plug SHD small SHD-20U-A-40 (Butyl Rubber/Black)	Butyl Rubber	2	
12	SCAD-40U-B-ALL	Drying hopper assembly	Assembly	1	
11	BY10050003150	Standard base HB-50	Assembly	1	
10	YE90052400300	Thermocouple 5×24L×HB×15M (SCAD-12U-A-37 Ver.A)	Assembly	1	
9	YW72153600000	Heat-resistant air pipe 15" double layers red×1.6m	Assembly	1	0.4m
8	YW02000200000	Stainless steel pipe clamp 2" (27.5MM) (pipe clamp head/pipe clamp made of SUS201)	SUS201	2	
7	YW64080600000	Hexagonal nut GB/T6170 M8-Longzinc		4	
6	SCAD-40U-ALL-02	Control box fixed plate	SPCC2.0	1	
5	SCAD-20U-A-ALL	Control box	Assembly	1	
4	YW65008000100	Standard spring washer GB/T93 8-Longzinc		12	
3	YW66081600000	Flat washer A grade GB/T93 18×16×1.6L-Longzinc		12	
2	YW60081600100	Hexagon bolt GB/T5781 M8×16-4.8-Longzinc		8	
1	SCAD-40U-HD-A-ALL	Dehumidifier assembly	Assembly	1	
序号	代号	名称	材料	数量	备注

					制图	版号	标题	图号	比例	数量
					设计	核准	SCAD-40U-HD		1:1	1
					校对		空压式干燥机			材质
标记	更改前	更改后	更改人	日期	审核	日期	SHINI	信易电热机械股份有限公司 Shini Plastics Technologies, Inc.	表面要求	物料号



Tech. Req: Unmarked dimensional tolerances shall comply with the GB/T1804-m requirement.

8	SCAD-20U-A-02	Heating case Inner box	Weldment	1	Assembly
7	YP60252000000	Aluminum platinum glass wool felt 25mm	Assembly	1	320mm×240mm
6	SCAD-20U-A-01	Heating case ext box	SPCC1.5	1	Assembly
5	YW67041200600	Cross socket pan head self-tapping lock screw GB6560 M6×12 Longzine		7	
4	YW63030600000	Cross recessed pan head screw GB/T-823 M3×6-Longzine		2	
3	BE85013000550	Temp protector K130 celsius(Length: 0.5M)(heater constant open)	Assembly	1	
2	BH70400100150	Pipe heater SCAD-40U-A-0112kW/1φ 220V/Ver.0	Assembly	1	
1	SCAD-20U-A-04	Insulation Silica gel	Silica gel 3.0	1	Assembly
序号	代号	名称	材质	数量	备注

					制图	黄学明	版号	0	标题	SCAD-40U 加热箱组件	图号	SCAD-40U-A-ALL	比例	1:2.5	数量	1
					设计	黄学明	核 准		 信易电热机械股份有限公司 Shini Plastics Technologies, Inc.				 表面要求			
					校对											物料号
标记	更改前	更改后	更改人	日期	审核		日期	20221125								

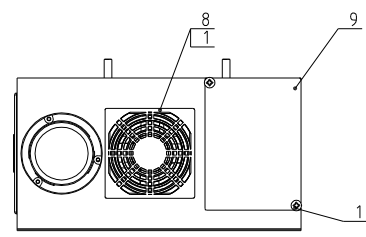
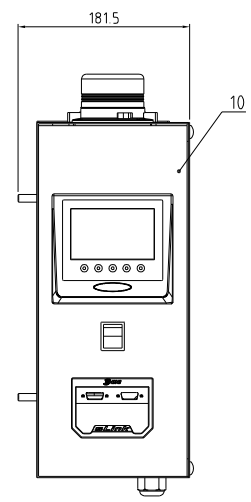
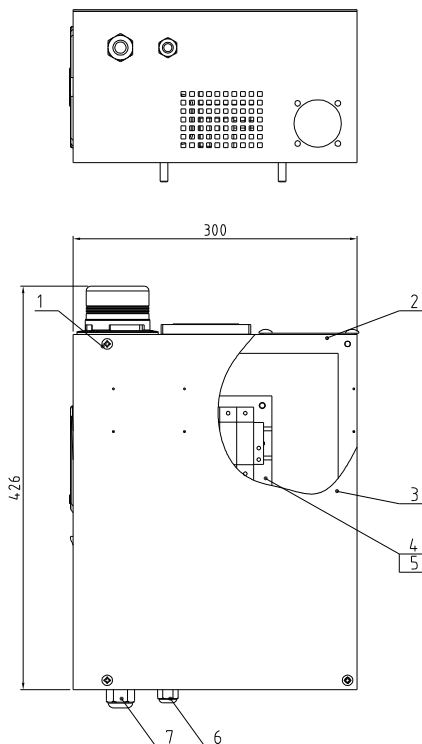

10	SCAD-20U-C-03	Control board	SPCC12	1	
9	SCAD-20U-C-05	Heating case cover	SPCC15	1	
8	YM60922500100	Exhaust fan - plastic air net 9225A1220V/240VAC50/60Hz	Assembly	1	
7	YE67181500100	Copper-nickel-plated cable joint 1.15-M8x15(15-3C for Cable)	Assembly	1	
6	YE6700094.0000	Cable lock head PG9	Assembly	1	
5	YW64.000500000	Hexagon nut M5 anti-loose		4	
4	SCAD-20U-C-04	Electrical component installation plate	SECC15	1	
3	SCAD-20U-C-02	Control box door	SPCC15	1	
2	SCAD-20U-C-01	Control box body	SPCC15	1	
1	YW67051000700	Cross socket pan head self-lapping lock screw GB6560 M5x10 L:Longzine		14	
序号	代号	名称	材料	数量	备注

					制图	版号	标题	图号	比例	数量
					设计	核准	SCAD-20U	SCAD-20U-C-ALL	1:1	1
					校对		控制箱		表面要求	材质
标记	更改前	更改后	更改人	日期	审核	日期	信易电热机械股份有限公司 Shini Plastics Technologies, Inc.		物料号	

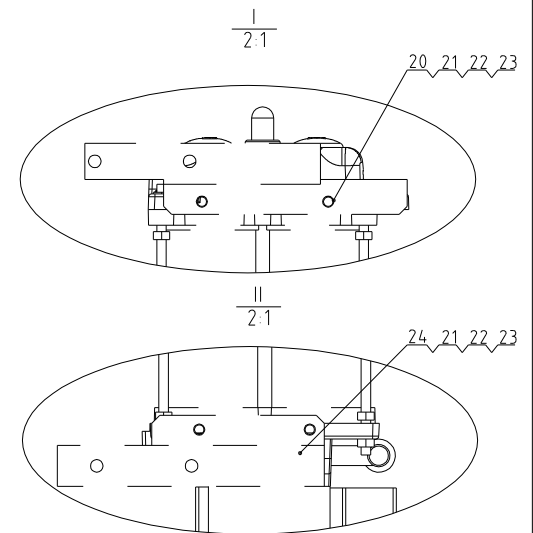
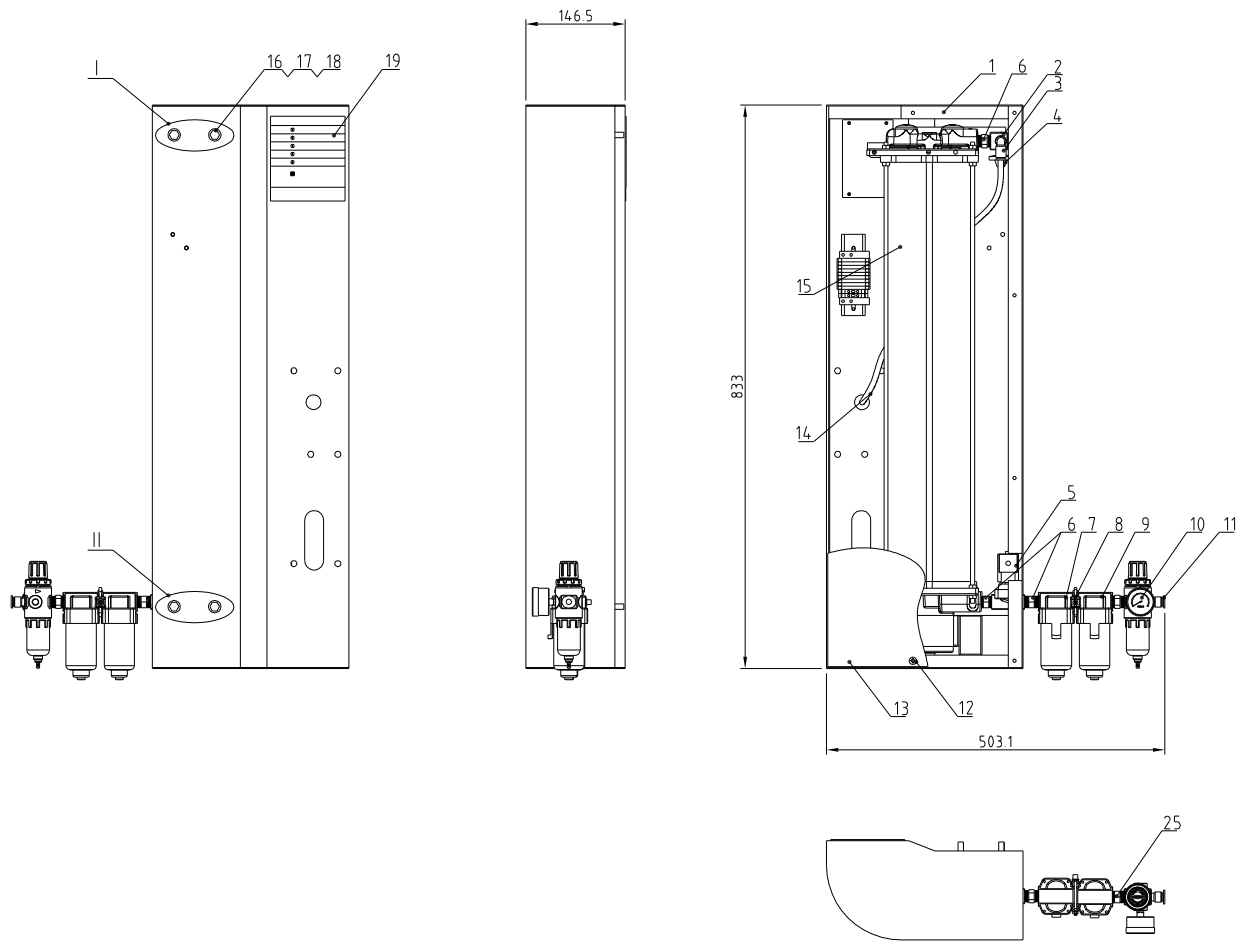

25	BH120104.00310	Copper connector 1/4T×3/8T(S-50)	H58	1	
24	SCAD-20U-HD-A-05	Lower fixed plate	SPCC3.0	1	
23	YW66061300000	Flat washer A grade GB/T97.16-Longzine		4	
22	YW65006000100	Standard spring washer GB/T93.6-Longzine		4	
21	YW61061200000	Hexagon socket head cap screw GB/T70.1 M6x12.9-Longzine		4	
20	SCAD-20U-HD-A-04	Upper fixed plate	SPCC3.0	1	
19	YE80011800000	Heatless operation panel		1	
18	YW66081600000	Flat washer A grade GB/T97.16 L×16×16/Longzine		4	
17	YW65008000100	Standard spring washer GB/T93.6-Longzine		4	
16	YW60081600000	Hex bolt GB/T5783 M8x16-12.9-Longzine		4	
15	BY90035600150	Heatless regen air dryer 0356/SCAD-40U-HD-A-02	Assembly	1	
14	YR60000800000	PU air pipe φ8×φ6 black 100M/roll		1	0.4m
13	SCAD-40U-HD-A-03	Dehumidifier fixed box plate	SPCC1.5	1	
12	YW67051000700	Cross socket pan head self-tapping lock screw GB6560 M5×10 Longzine		8	
11	YW80081400000	Thread direct connector APC8-02 1/4-118/Air TAC10(pcs/bag)		1	
10	YE30200020000	Filter pressure regulating valve AFR-2000	Assembly	1	
9	YR50300300700	Oil mist separator AFM30-03D-A(SMC)	Assembly	1	
8	YW09030001500	Baffle plate IXIY300-A(SMC)	Assembly	1	
7	YR50300300600	Oil mist separator AFD30-03D-A(SMC)	Assembly	1	
6	BH12030800110	Copper connector 3/8PT-3/8PT(S-07)		3	
5	YE32382400000	Solenoid valve 3/8 oil type (Kailing)24VAC model VXD130-10DJ with connection box	Assembly	1	
4	YE15020400300	Pressure switch LF20 4kPa	Assembly	1	
3	YW80083800200	L thread connector APL8-03 3/8-118/Air TAC10 pcs/pack	Assembly	1	
2	BH12126200010	Air pipe connector three way SCAD-12U-A-28(H6Z)	H6Z	1	
1	SCAD-40U-HD-A-01	Dehumidifier fixed case	SPCC1.5	1	

序号	代号	名称	材料	数量	备注
		标题 SCAD-40U-HD	图号 SCAD-40U-HD-A-ALL	比例	数量
		除湿机组件			材质
			信易电热机械股份有限公司 Shini Plastics Technologies, Inc.	表面要求	物料号
制图	设计	校对	审核	日期	日期
标记	更改前	更改后	更改人	日期	日期

Compressed air flow	Drying heater power	Hopper capacity	Model Version
12m ³ /hr	600W	20L	Ver.C

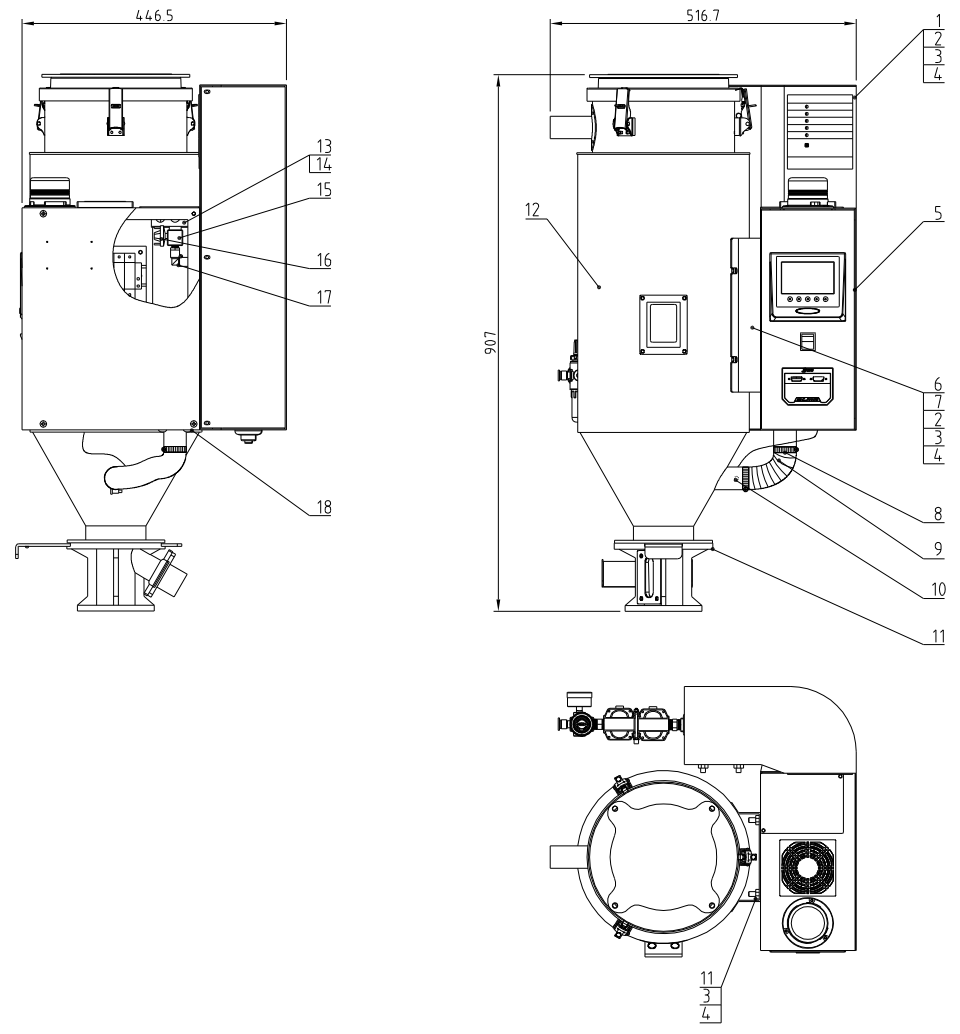

18	YW67051000700	Cross socket pan head self-tapping lock screw GB8560 M5x10 L=10.5mm		4	
17	YW80083800200	L thread connector APLB-03 3/8"-0.8(Air TAC110 pcs/pack)	Assembly	1	
16	YE1520400300	Pressure switch LP20 4kPa	Assembly	1	
15	BH12126200010	Air pipe connector three way SCAD-12U-A-28H62	H62	1	
14	SCAD-20U-D-ALL	Heating case assembly	Assembly	1	
13	YR3000000200	Rubber plug SHD small SHD-20U-A-40 (Butyl Rubber/Nitrile)	Butyl Rubber	2	
12	SCAD-20U-B-ALL	Drying hopper assembly	Assembly	1	
11	BY10012003150	Standard base assembly HB-12(Ver.B)	Assembly	1	
10	YE90052400300	Thermocouple S-24L-MB-15M (SCAD-12U-A-37 Ver.A)	Assembly	1	
9	YW72153600000	Heat-resistant air pipe 15" double layers rad=3.6m	Assembly	1	0.4m
8	YW02000200000	Stainless steel pipe clamp 2"127-5MM(pipe clamp head/pipe clamp made of SUS201)	SUS201	2	
7	YW64080600000	Hexagonal nut GB/T6170 MB-Longzinc		4	
6	SCAD-20U-ALL-01	Control box fixed plate	SPCC2.0	1	
5	SCAD-20U-C-ALL	Control box	Assembly	1	
4	YW65008000100	Standard spring washer GB/T93 8-Longzinc		12	
3	YW66081600000	Flat washer A grade GB/T97.118 4-16-16L Longzinc		12	
2	YW60081600100	Hexagon bolt GB/T5781 M8x16-4-8-Longzinc		8	
1	SCAD-20U-HD-A-ALL	Dehumidifier assembly	Assembly	1	

序号	代号	名称	材料	数量	备注
		SCAD-20U-HD 空压式干燥机	SCAD-20U-HD-ALL	18	数量 1
					材质
					表面要求
					物料号

制图	黄学明	版号	0
设计	黄学明	核准	
校对		审核	
标记	更改前	更改后	更改人
			日期
			日期

SHINI 信易电热机械股份有限公司
Shini Plastics Technologies, Inc.

标题 SCAD-20U-HD
空压式干燥机

图号 SCAD-20U-HD-ALL

比例 18
数量 1
材质
表面要求
物料号

20221125

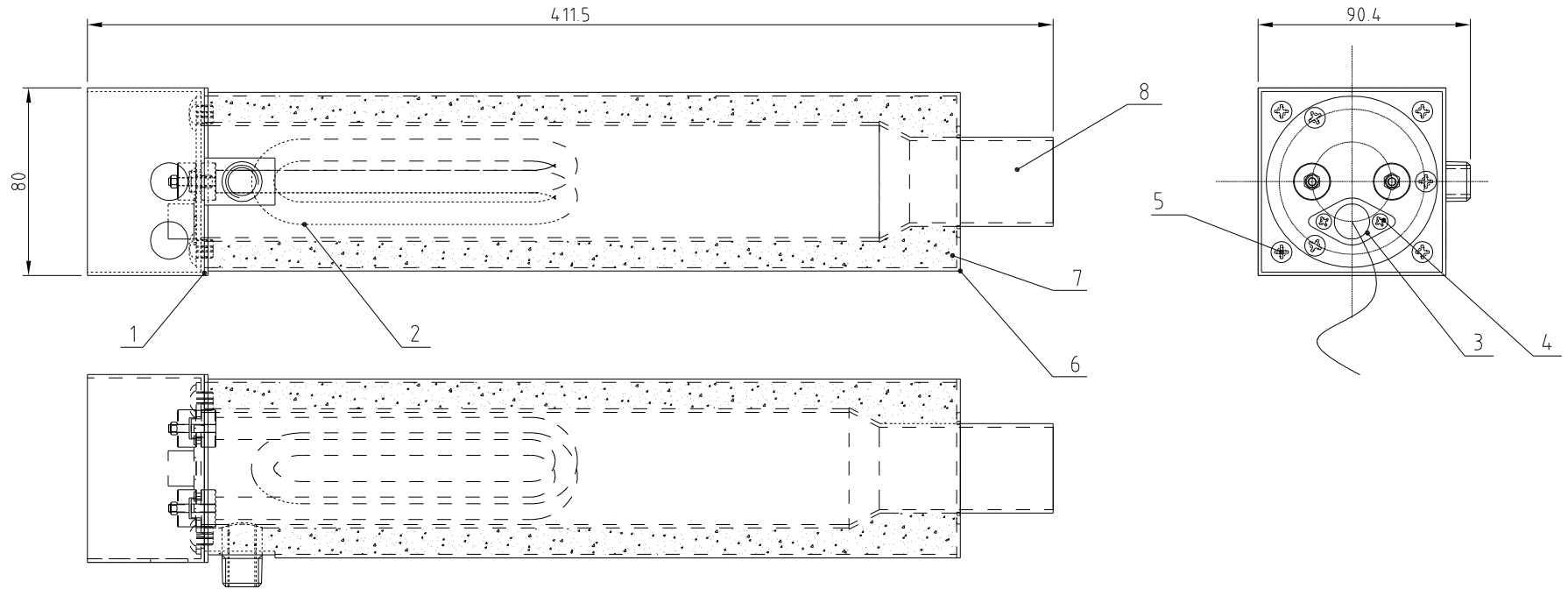

8	SCAD-20U-A-02	Heating case Inner box	Weldment	1	
7	YP60252000000	Aluminum platinum glass wool felt 25mm	Assembly	1	320mm×240mm
6	SCAD-20U-A-01	Heating case ext box	SPCC1.5	1	
5	YW67041200600	Cross socket pan head self-lapping lock screw GB6560 M4×12 Longzine		7	
4	YW63030600000	Cross recessed pan head screw GB/T-823 M3×6-Longzine		2	
3	BE85013000550	Temp. protector K130 celsius(Length 0.5M)(heater constant open)	Assembly	1	
2	BH70402000110	Pipe heater SCAD-20U-A-0910 6KW/1φ 220V(Ver 0)	Assembly	1	
1	SCAD-20U-A-04	Insulation Silica gel	Silica gel 3.0	1	
序号	代号	名称	材质	数量	备注

					制图	版号	标题	图号	比例	数量
					设计	核准	SCAD-20U 加热箱组件	SCAD-20U-A-ALL		材质
					校对		信易電熱機械股份有限公司 Shini Plastics Technologies, Inc.	表面要求		
标记	更改前	更改后	更改人	日期	审核	日期		物料号		

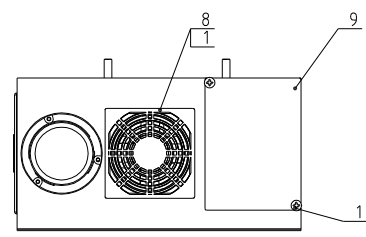
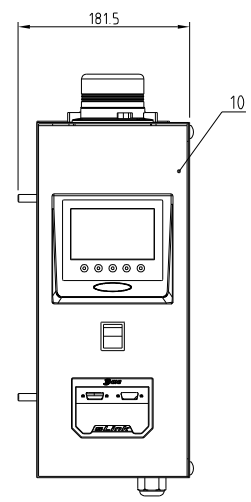
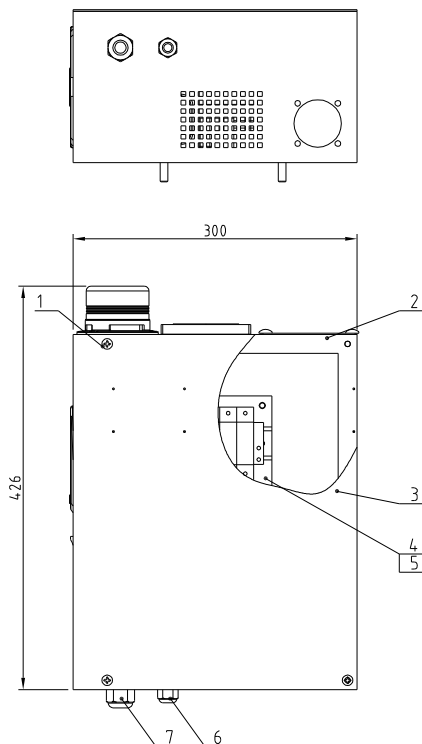

序号	代号	名称	材料	数量	备注
10	SCAD-20U-C-03	Control board	SPCC12	1	
9	SCAD-20U-C-05	Heating case cover	SPCC15	1	
8	YM60922500100	Exhaust fan - plastic air net 9225A1220V/240VAC50/60Hz	Assembly	1	
7	YE67181500100	Copper-nickel-plated cable joint 1.15-M8x5115-3C for Cable	Assembly	1	
6	YE6700094.0000	Cable lock head PG9	Assembly	1	
5	YW64.000500000	Hexagon nut M5 anti-loose		4	
4	SCAD-20U-C-04	Electrical component installation plate	SECC15	1	
3	SCAD-20U-C-02	Control box door	SPCC15	1	
2	SCAD-20U-C-01	Control box body	SPCC15	1	
1	YW67051000700	Cross socket pan head self-lapping lock screw GB6560 M5x10 L:Longzine		14	

标记	更改前	更改后	更改人	日期	制图	版号	标题	图号	比例	数量	备注
					设计	核准	SCAD-20U 控制箱	SCAD-20U-C-ALL	1:1	1	材质
					校对		信易电热机械股份有限公司 Shini Plastics Technologies, Inc.	表面要求			
					审核	日期		物料号			

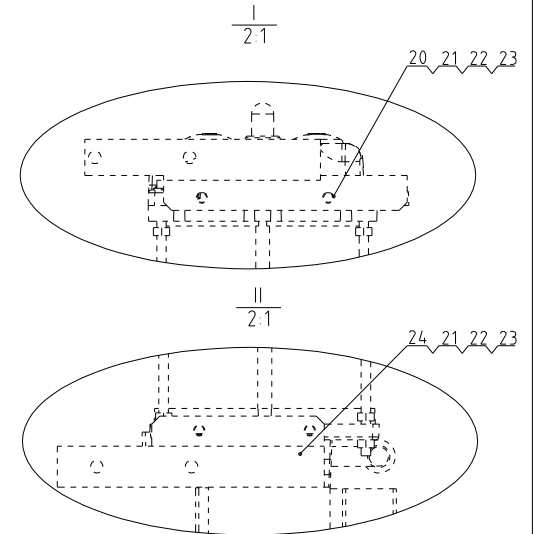
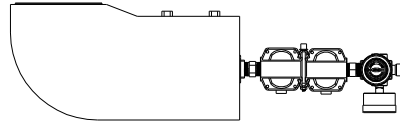
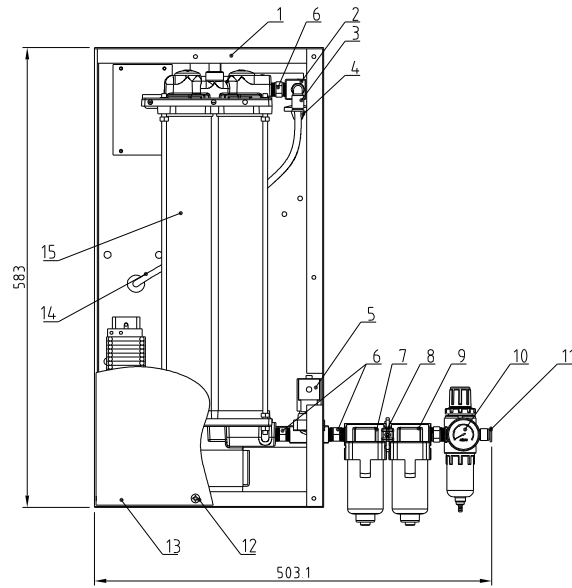
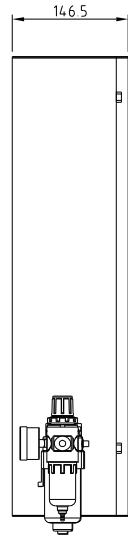
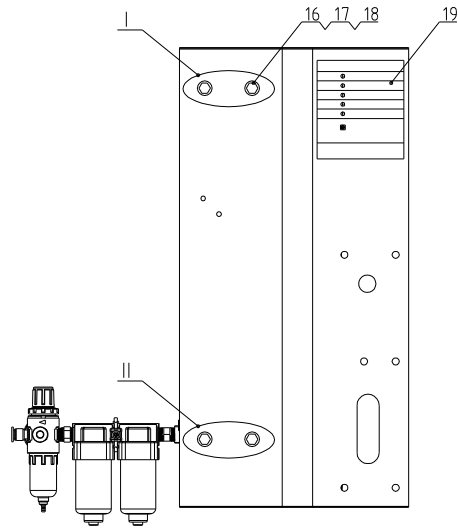

25	BH120104.00310	Copper connector 1/4T×3/8T(S-50)	H58	1	
24	SCAD-20U-HD-A-05	Lower fixed plate	SPCC3.0	1	
23	YW66061300000	Flat washer A grade GB/T9711.6-Longzine		4	
22	YW65006000100	Standard spring washer GB/T93 6-Longzine		4	
21	YW61061200000	Inner hex column head screw GB/T70.1 M6x12-12.9-Longzine		4	
20	SCAD-20U-HD-A-04	Upper fixed plate	SPCC3.0	1	
19	YE80011800000	Heatless operation panel		1	
18	YW66081600000	Flat washer A grade GB/T9711.6-Longzine		4	
17	YW65008000100	Standard spring washer GB/T93 8-Longzine		4	
16	YW60081600000	Hexagon bolt GB/T5783 M8x16-12.9-Longzine		4	
15	BY90200200150	Heatless regen air dryer 0206/SCAD-20U-HD-A-02	Assembly	1	
14	YR60000800000	PU air pipe φ8×φ6 black 100M/roll		0.4m	
13	SCAD-20U-HD-A-03	Dehumidifier fixed box plate	SPCC1.5	1	
12	YW67051000700	Cross socket pan head self-tapping lock screw GB6560 M5×10 Longzine		8	
11	YW800814.000000	Thread direct connector APC8-02 1/4-0.8(AirTAC)10 pcs/bag		1	
10	YE30200020000	Filter pressure regulating valve AFR-2000	Assembly	1	
9	YR50300300700	Oil mist separator AFM30-03D-A(SMC)	Assembly	1	
8	YW09030001500	insulated plate XIY300-A(SMC)	Assembly	1	
7	YR50300300600	Oil mist separator AFD30-03D-A(SMC)	Assembly	1	
6	BH12030800110	Copper connector 3/8PT×3/8PT(S-07)		3	
5	YE323824.000000	Solenoid valve 3/8 on type (Kaling)24VAC model VXD2130-100J with connection box	Assembly	1	
4	YE150204.003000	Pressure switch LF20 4kPa	Assembly	1	
3	YW800083800200	L thread connector APLB-03 3/8-0.8(AirTAC)10 pcs/pack	Assembly	1	
2	BH12126200010	Air pipe connector three way SCAD-12U-A-28H402	H62	1	
1	SCAD-20U-HD-A-01	Dehumidifier fixed case	SPCC1.5	1	

序号	代号	名称	材料	数量	备注
		标题 SCAD-20U-HD	图号 SCAD-20U-HD-A-ALL	比例	数量
		除湿机组件		1:1	材质
			SHINI 信易电热机械股份有限公司 Shini Plastics Technologies, Inc.	表面要求	
标记	更改前	更改后	更改人	日期	审核
					日期