

BCF

Belt Conveyor

Date: Jun, 2016

Version: Ver.A (English)



Contents

1. General Description	7
1.1 Coding Principle.....	8
1.2 Feature	8
1.3 Technical Specifications	10
1.3.1 Dimensions.....	10
1.4 Safety Regulations.....	11
1.4.1 Safety Signs and Labels.....	11
1.5 Exemption Clause.....	13
2. Structural Features and Working Principle.....	14
2.1 Function Description	14
2.1.1 Working Principle.....	14
2.2 Assembly Drawing	16
2.2.1 Assembly Drawing.....	16
2.2.2 Parts list.....	17
2.2.3 Holder Parts	19
2.2.4 Pedestal Parts	20
2.3 Electrical Circuit Diagram.....	21
2.3.1 Main Electrical Circuit.....	21
2.3.2 Electrical Components List	22
3. Installation Testing.....	23
3.1 Positioning	23
3.2 Power Connections.....	24
4. Use and operation	26
4.1 Operation instructions.....	26
4.2 Main Parameter List of the Speed Regulator	28
5. Trouble Shooting.....	30
6. Service and Maintenance	31
6.1 Repair	31
6.2 Maintenance	31
6.2.1 Maintenance of the Gear Motor.....	31

6.2.2 Clearance of the Machine.....	32
6.2.3 Lubricate the Bearing	33
6.3 Adjusting the Central Postion of the PU Belt.....	34
6.4 Maintenance Schedule	35
6.4.1 About the Machine.....	35
6.4.2 Check After Installation.....	35
6.4.3 Daily Checking	35
6.4.4 Weekly Checking.....	35

Table index

Table 1-1: Dimensions List	10
Table 2-1: Parts List (BCF-3650)	17
Table 2-2: Parts List (BCF-3675/ 4360)	17
Table 2-3: Parts List (BCF-4390/5080/7090/6080S)	18
Table 2-4: Parts List (BCF-50110/70120/75120S)	18
Picture 2-3: Holder Parts.....	19
Table 2-5: Parts List.....	19
Table 2-6: Parts List.....	20

Picture index

Picture 1-1: Dimensions.....	10
Picture 2-1: Working Principle.....	14
Picture 2-2: Assembly Drawing.....	16
Picture 2-3: Holder Parts.....	19
Picture 2-4: Pedestal Parts	20
Picture 2-5: Main Electrical Circuit	21
Picture 2-6: Electrical Components List	22
Picture 3-1: Horizontal Installation	23
Picture 3-2: Power Connections	24
Picture 3-3: Machine Installation Drawing.....	25
Picture 6-1: Gear Motor	32
Picture 6-2: Bearing Lubricate Brawing.....	33

Picture 6-3: PVC Adjusting Drawing34

1. General Description



Please read this manual carefully before using this machine in order to operate correctly against any damage caused due to improper operation.



Forbidden to process flammable or toxic material!

Shini has specially designed the BCF series Belt Conveyor to collocate with the Granulator, which can easily convey the material to the cutting chamber for granulating with the BCF Belt Conveyor.



Model: BCF-5080

1.1 Coding Principle

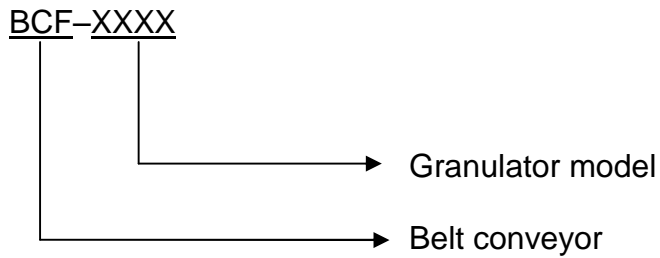

1.2 Feature

- PVC belt is adopted for smooth and efficient conveying.
- Can optionally material fence to facilitate regrind conveying.
- Sidewalls for 75 mm respectively.
- Equipped with speed regulators as standard. The safe regulating range for normal use is 3~6m/min.

All service work should be carried out by a person with technical training or corresponding professional experience. The manual contains instructions for both handling and servicing. Chapter 6, which contains service instructions intended for service engineers. Other chapters contain instructions for the daily operator.

Any modifications of the machine must be approved by SHINI in order to avoid personal injury and damage to machine. We shall not be liable for any damage caused by unauthorized change of the machine.

Our company provides excellent after-sales service. Should you have any problem during using the machine, please contact the company or the local vendor.

Headquarter and Taipei factory:

Tel: (886) 2 2680 9119

Shini Plastics Technologies (Dongguan), Inc:

Tel: (86) 769 8111 6600

Shini Plastics Technologies India Pvt.Ltd. :

Tel: (91) 250 3021 166

1.3 Technical Specifications

1.3.1 Dimensions

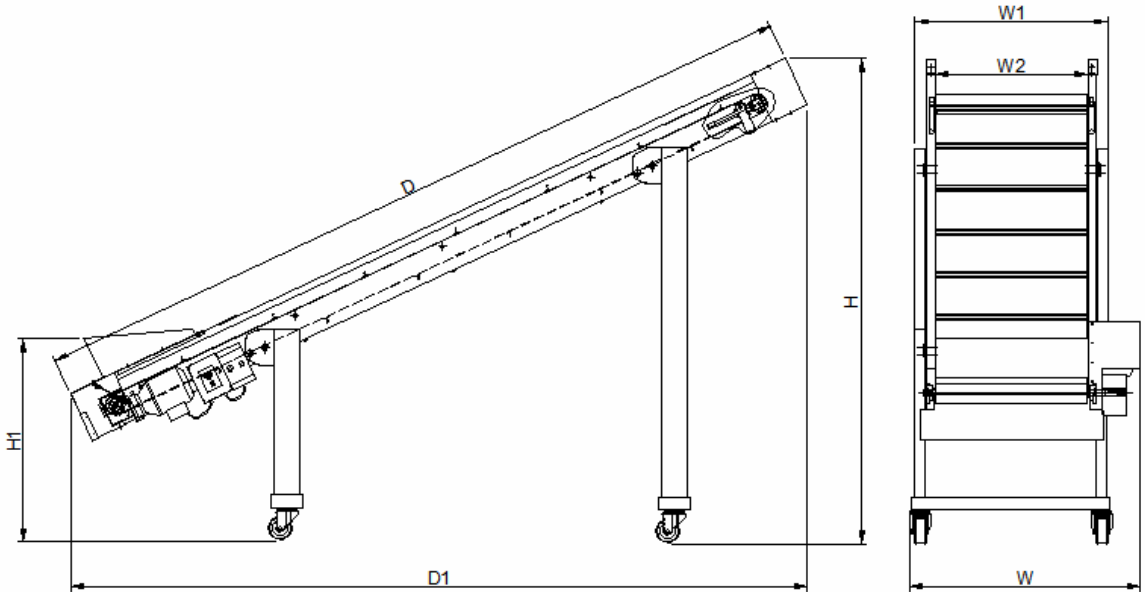

Picture 1-1: Dimensions

Table 1-1: Dimensions List

Model BCF	3650	3675	4360	4390	5080	50110	7090	70120	6080S	75120S
W (mm)	805	905	905	1105	1105	1305	1105	1305	1105	1305
W1 (mm)	571	671	671	871	871	1071	871	1071	871	1071
W2 (mm)	500	600	600	800	800	1000	800	1000	800	1000
D (mm)	3092	3092	3092	3092	4092	4092	5092	5092	4092	5092
D1 (mm)	2887	2887	2777	2777	3643	3643	4509	4509	3643	4509
H(mm)	1864	1894	2033	2033	2509	2509	3173	3173	2659	2973
H1(mm)	771	794	705	705	681	681	846	846	681	646

We reserve the right to change specifications without prior notice.

1.4 Safety Regulations

To avoid any body injures and damages of the machine, please obey the regulations in this manual. When operating this machine, please obey the regulations as follows.

1.4.1 Safety Signs and Labels



Electrical installation should be done by qualified electricians. Turn off the main switch and control switch before servicing and maintenance.



Warning!

The sound level produced by the machine is < 85dB (max) at the position of the operator.



Notice:

Noise level test refers to the following conditions: 1m around the machine, 1.6m above the machine.



Warning!

- 1) Don't use the machine and don't try to repair it before carefully read this manual and understood all its parts completely.
- 2) In particular, it is important to adopt the precaution listed in section a 'safety instruction'.
- 3) It is forbidden to use the machine in any condition or for any use different from what is indicated in the manual. SHINI has no responsibility for breakdowns, trouble, or injuries caused by improper operation.



Attention!

No need for regular inspection because all the electrical parts in the control unit are fixed tightly!



Attention!

The maximum weight of the pieces to be carried on the conveyor belt must not be over 56kg in total (Conveying capacity is less than 56kg as the set value of the regulator is smaller than 4.5m/min).

The conveyor belts are not suitable to transport loose material.



Attention!

These conveyor belts can be easily used by all of the personnel of the plant they are installed in, and they do not present any risk for the operator, if used properly.

Therefore, it is recommended to read the manual carefully before using the machine.



Attention!

SHINI claims no responsibility when:

- 1) Use of the conveyor belt is in any way openly opposed to what is indicated in the present instruction manual.
- 2) There are feeding defects.
- 3) There is a serious deficiency of the foreseen maintenance.
- 4) Non-authorized changes are adopted.
- 5) Spare parts that are non-authorized or not suitable for the actual model are used.



Danger!

Risk of fire: Risk of fire is present whenever the conditions of the conveyor belts are not suitable for the operation they are used for (in particular: temperature of the pieces carried). Adjust the condition of the conveyor belt according to the table shown here below.



Risks of high temperature: These conveyor belts are designed for transporting molded parts, i.e. hot pieces. If you need to operate on the conveyor belt, use safety gloves (in particular where the parts fall on the belt).

Type of belt	Max. temp. of parts
PVC	80°C



Attention!

The packing material must not be left around, and it must be disposed of according to the regulations in force. It is possible to lift the conveyor with a fork lift.



Danger!

To protect the operator's safety, and the integrity of the machine, assure the stable lifting of the conveyor. Once the conveyor belt is running, it is necessary to fix the machine by locking the castors.

1.5 Exemption Clause

The following statements clarify the responsibilities and regulations born by any buyer or user who purchases products and accessories from Shini (including employees and agents).

Shini is exempted from liability for any costs, fees, claims and losses caused by reasons below:

1. Any careless or man-made installations, operation and maintenances upon machines without referring to the Manual prior to machine using.
2. Any incidents beyond human reasonable controls, which include man-made vicious or deliberate damages or abnormal power, and machine faults caused by irresistible natural disasters including fire, flood, storm and earthquake.
3. Any operational actions that are not authorized by Shini upon machine, including adding or replacing accessories, dismantling, delivering or repairing.
4. Employing consumables or oil media that are not appointed by Shini.

2. Structural Features and Working Principle

2.1 Function Description

BCF Belt Conveyor collocated with the Granulator directly, with stable performance and easy of operation.

2.1.1 Working Principle

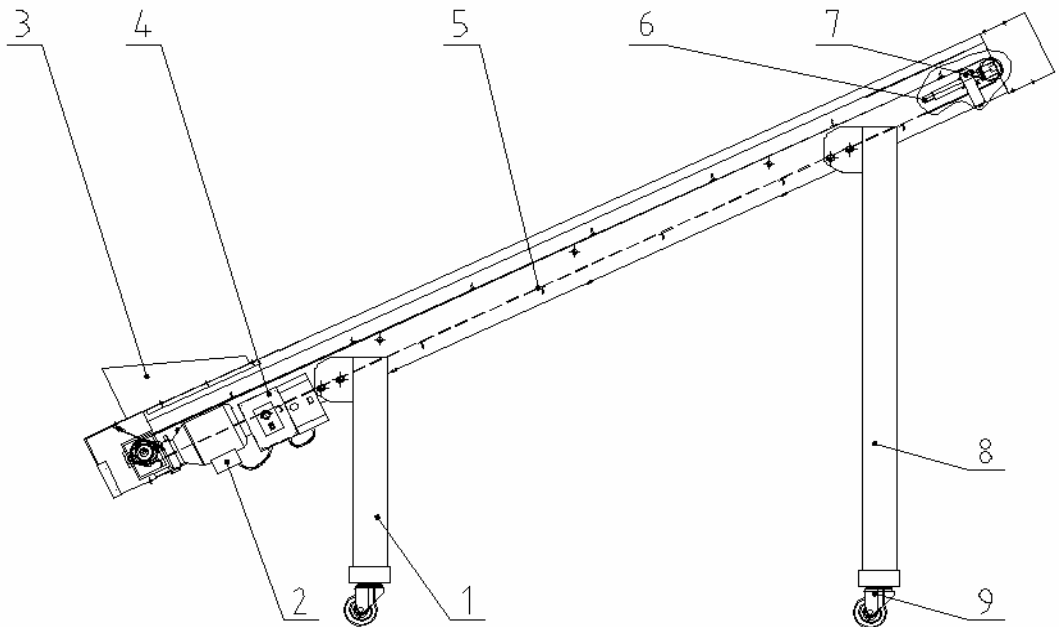

Parts name:

- | | | | |
|----------------------|------------------|------------------------|------------------|
| 1. Base1 | 2. Gear motor | 3. Barrier | 4.Speed governor |
| 5. PVC belt | 6. Plug in screw | 7. Adjusting screw nut | 8. Base2 |
| 9. Castor with brake | | | |

Picture 2-1: Working Principle

The conveyor belts of this series are made up of:

The base 1 and base 2 (1) (8), each with 2 with locking casters (9), the conveyor belt can be easily moved to the working area.

The conveying rotor located on the first end is directly connected to the gear motor (2).

Matched with the motor, there is a speed regulator (4) which has the function to start, stop and regulate the belt. The screw nut (7) connected to the butterfly screw (6), is used for adjusting the height of conveyor, and there are two knobs will be used for controlling the moving direction and tightness degree.

2.2 Assembly Drawing

2.2.1 Assembly Drawing

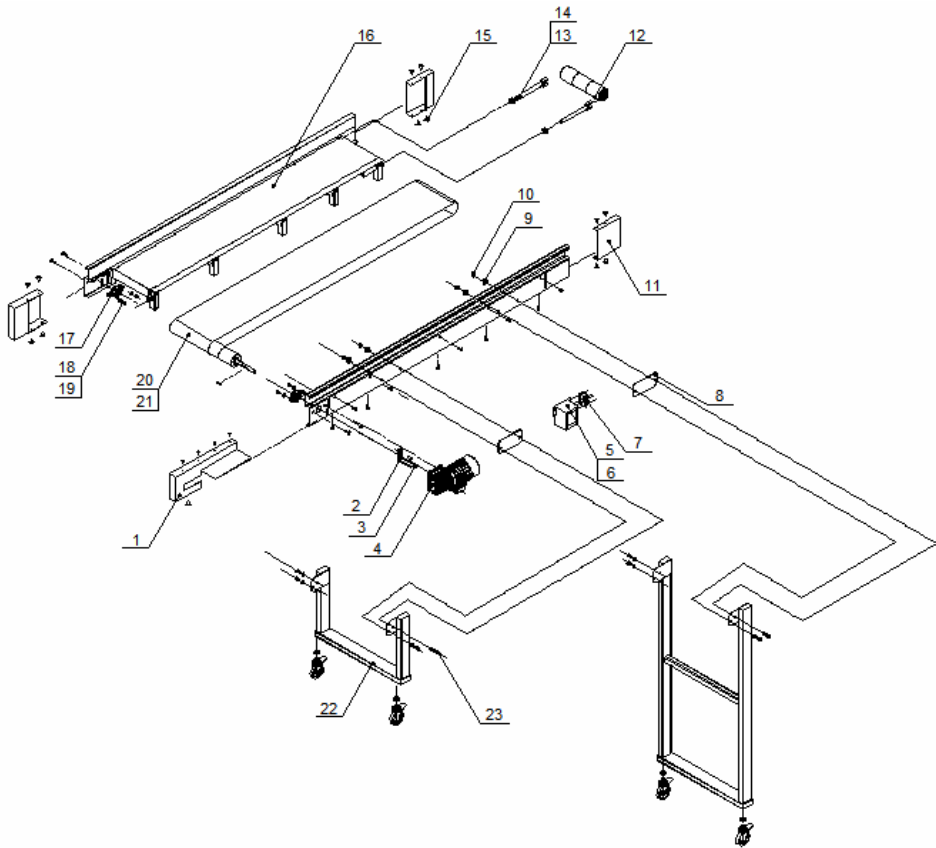

Note: Please refer to 2.2.2 material list about the parts code.

Picture 2-2: Assembly Drawing

2.2.2 Parts list

Table 2-1: Parts List (BCF-3650)

No.	Name	Part No.	No.	Name	Part No.
1	End cover 2	BL56000042020	13	Butterfly screw	BH10401101140
2	Motor holder	BL56000000420	14	Hexagon thin nut	YW64200100000
3	Hexagon screw bolt	YW60082500300	15	Hexagon self-tapping screw	YW66061210000
4	Gear motor	YM50102500000	16	Conveying belt assembly map	-
5	Speed governor shell	BL56000240020	17	Bearing block parts	YW11205100100
6	Speed governor cover	BL56000140020	18	Flat gasket	YW66122400000
7	Speed governor	YE80200000100	19	Star screw nut	YW64012100000
8	Holder pad	BL56004300020	20	Conveying belt	YR00520000200
9	Gasket	YW66122400000	21	Conveying wheel	YW08044501700
10	Star screw nut	YW64012100000	22	Exploded view of pedestal	-
11	End cover 1	BL56000041020	23	Hexagon screw bolt	YW60122500100
12	Iron stick	YW08050600600			

Table 2-2: Parts List (BCF-3675/ 4360)

No.	Name	Part No.	No.	Name	Part No.
1	End cover 2	BL56000042020	13	Butterfly screw	BH10401101140
2	Motor holder	BL56000000420	14	Hexagon thin nut	YW64200100000
3	Hexagon screw bolt	YW60082500300	15	Hexagon self-tapping screw	YW66061210000
4	Gear motor	YM50102500000	16	Conveying belt assembly map	-
5	Speed governor shell	BL56000240020	17	Bearing block parts	YW11205100100
6	Speed governor cover	BL56000140020	18	Flat gasket	YW66122400000
7	Speed governor	YE80200000100	19	Star screw nut	YW64012100000
8	Holder pad	BL56004300020	20	Conveying belt	YR00620000200
9	Gasket	YW66122400000	21	Conveying wheel	YW08046004500
10	Star screw nut	YW64012100000	22	Exploded view of pedestal	-
11	End cover 1	BL56000041020	23	Hexagon screw bolt	YW60122500100
12	Iron stick	YW09502800000			

* means possible broken parts.

** means easy broken part. and spare backup is suggested.

Please confirm the version of manual before placing the purchase order to guarantee that the item number of the spare part is in accordance with the real object.

Table 2-3: Parts List (BCF-4390/5080/7090/6080S)

No.	Name	Part No.	No.	Name	Part No.
1	End cover 2	BL56000042020	13	Butterfly screw	BH10401101140
2	Motor holder	BL56000000420	14	Hexagon thin nut	YW64200100000
3	Hexagon screw bolt	YW60082500300	15	Hexagon self-tapping screw	YW66061210000
4	Gear motor	YM50102500000	16	Conveying belt assembly map	-
5	Speed governor shell	BL56000240020	17	Bearing block parts	YW11205100100
6	Speed governor cover	BL56000140020	18	Flat gasket	YW66122400000
7	Speed governor	YE80200000100	19	Star screw nut	YW64012100000
8	Holder pad	BL56004300020	20	Conveying belt	YR00420007500
9	Gasket	YW66122400000	21	Conveying wheel	YW08047004500
10	Star screw nut	YW64012100000	22	Exploded view of pedestal	-
11	End cover 1	BL56000041020	23	Hexagon screw bolt	YW60122500100
12	Iron stick	YW08047007800			

Table 2-4: Parts List (BCF-50110/70120/75120S)

No.	Name	Part No.	No.	Name	Part No.
1	End cover 2	BL56000042020	13	Butterfly screw	BH10401101140
2	Motor holder	BL56000000420	14	Hexagon thin nut	YW64200100000
3	Hexagon screw bolt	YW60082500300	15	Hexagon self-tapping screw	YW66061210000
4	Gear motor	YM50102500000	16	Conveying belt assembly map	-
5	Speed governor shell	BL56000240020	17	Bearing block parts	YW11205100100
6	Speed governor cover	BL56000140020	18	Flat gasket	YW66122400000
7	Speed governor	YE80200000100	19	Star screw nut	YW64012100000
8	Holder pad	BL56004300020	20	Conveying belt	YR00420008500
9	Gasket	YW66122400000	21	Conveying wheel	YW08048004500
10	Star screw nut	YW64012100000	22	Exploded view of pedestal	-
11	End cover 1	BL56000041020	23	Hexagon screw bolt	YW60122500100
12	Iron stick	YW08047008800			

* means possible broken parts.

** means easy broken part. and spare backup is suggested.

Please confirm the version of manual before placing the purchase order to guarantee that the item number of the spare part is in accordance with the real object.

2.2.3 Holder Parts

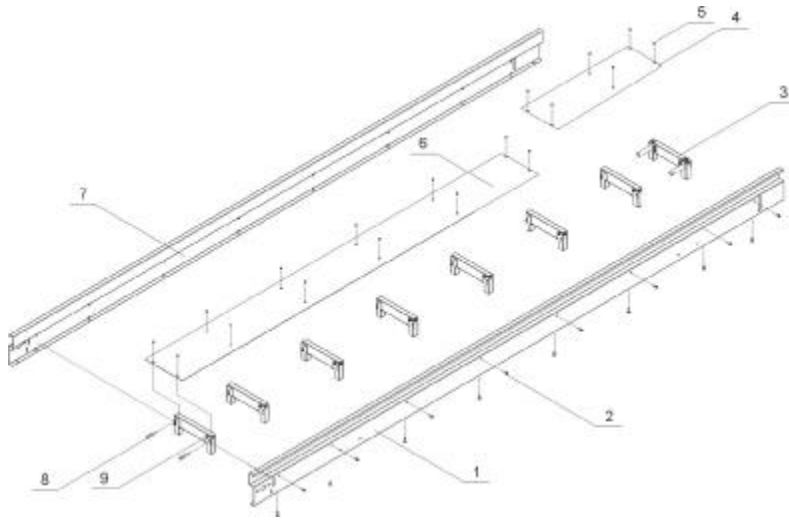

Picture 2-3: Holder Parts

Table 2-5: Parts List

No.	Name	Part No.
1	Side plate	-
2	Hexagon screw bolt	YW60082500100
3	Assembly drawing of beam 2	-
4	Plate 2	-
5	cross socket counter sunk head screw	YW69042310001
6	Plate 1	-
7	Side plate2	-
8	Hexagonal screw	-
9	Assembly drawing of beam 1	-

2.2.4 Pedestal Parts

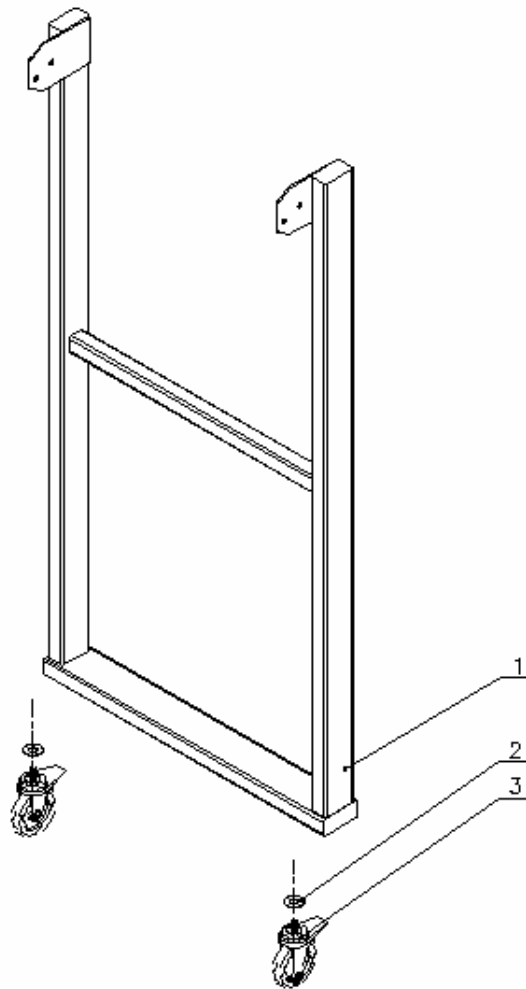

Picture 2-4: Pedestal Parts

Table 2-6: Parts List

No.	Name	Part No.
1	Base	-
2	Flat gasket	YW0301000000
3	Castor	YW66123200100

2.3 Electrical Circuit Diagram

2.3.1 Main Electrical Circuit

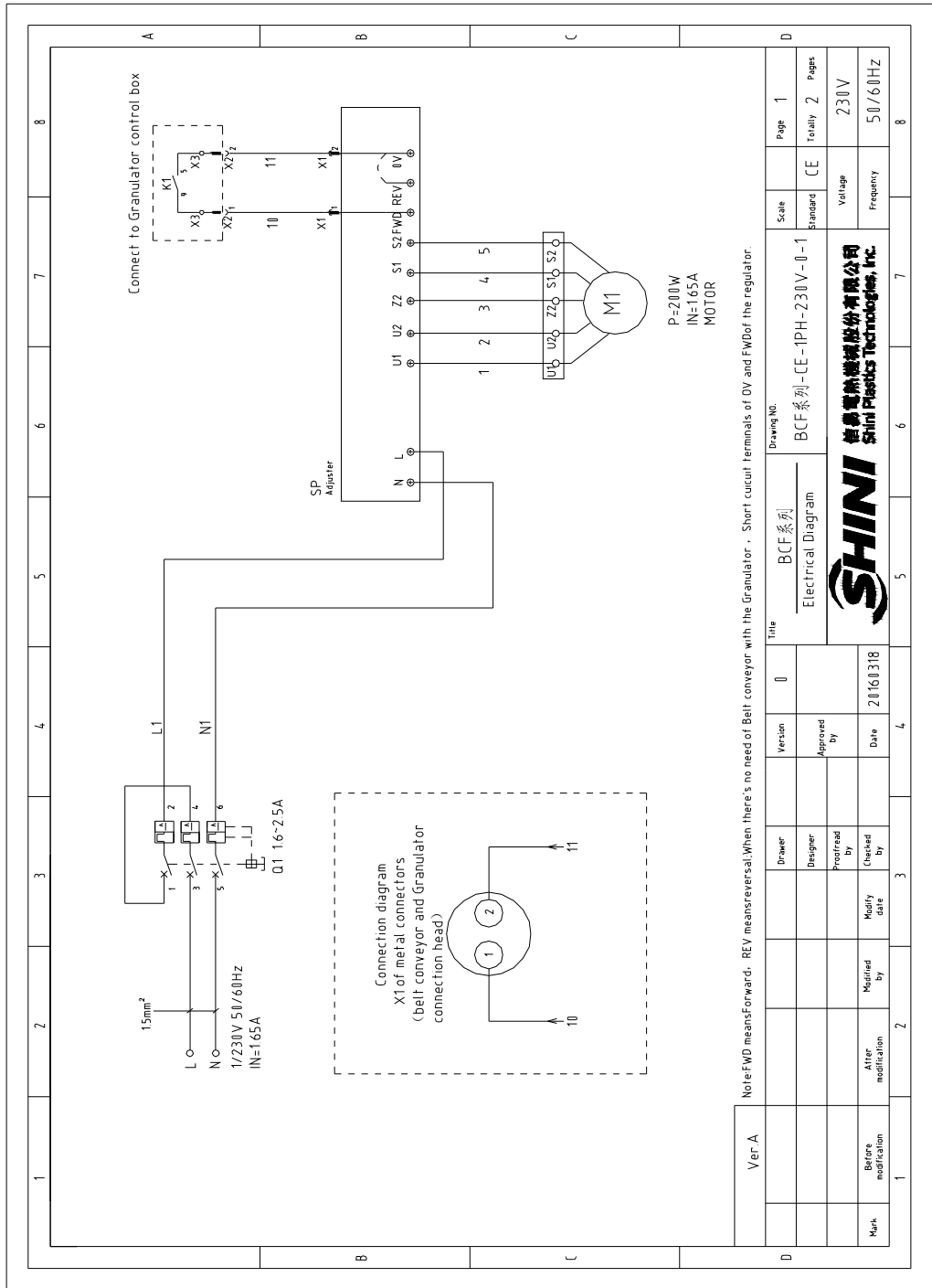

Picture 2-5: Main Electrical Circuit

2.3.2 Electrical Components List

1		2		3		4		5		6		7		8	
NO	Symbol	Name	Manufacturer	Type	Specification	Number	Material number	Remark							
1	Q1	Thermomagnet circuit breaker	CHNT	NSZ-25	1.6-2.5A	1	YE10162500100								
2		Waterproof-box	CHNT	NSZ-MC	----	1	YR4.001200000								
3	X1	Metal joint	SHINI	PLT-162-RRIM	2P	1	YE68016200100		A						
4	X2		SHINI	PLT-162-PRIFEI	2P	1	YE68016200000	[1]							
5			SHINI	PLT-162-PRIFEI	2P	1	YE68016200000	[1]							
6	SP	Speed governor	JSCC	SF210E	231V 50/60HZ 200W	1	YE8200000100								
7	M1	Motor	JSCC	100YT200GV11	231V 200W 50/60HZ	1	-----	[1]							
Notes: [1]Means it's not the material inside the control box															
Ver. A		Notes: [1]Means it's not the material inside the control box		Drawer		Version		Title		Drawing No.		Scale		Page	
				Designer		Approved by		BCF系列 Electrical Components List 1		BCF系列-CE-IPH-231V-0-2		Standard		Totaly 2	
				Proofread by		Date		SHINI 信譽電機機械股份有限公司 Shini Electric Technology, Inc.		Voltage		CE		2	
Mark		Before modification		Modified by		Modify date		20160318		Frequency		50/60HZ		8	

Picture 2-6: Electrical Components List

3. Installation Testing

Read this chapter carefully before installation, Must observe the installation steps as follows!



The connection of the power supply should be done by qualified electricians only!

3.1 Positioning

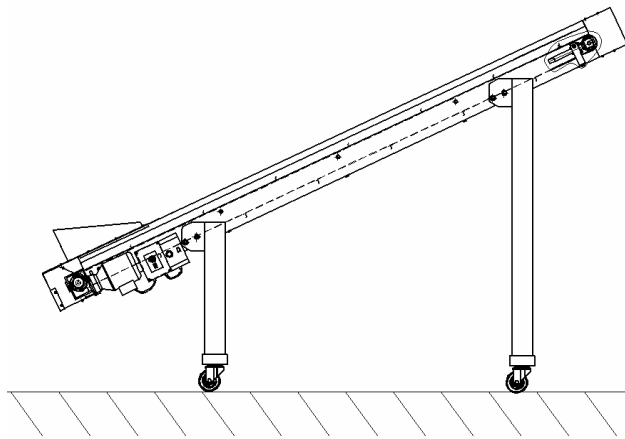

Picture 3-1: Horizontal Installation

Conveyor don't require any particular preliminary operation before starting-up. This machine should be mounted on horizontal plane. The machine would be shifting if there's large incline on the ground.

3.2 Power Connections

Specific power access specifications, please refer to the models of the circuit diagram

- 1) Verify that the power supply corresponds to the specifications of the plate near the controls of the conveyor.
- 2) Connect the power cable and the PE wire according to the local regulations.
- 3) Use independent power cable and switch, Make sure that the diameter of the cable is not smaller than the cable used in the control box.
- 4) The connection end of the power cable should be safely and tightly.
- 5) This series use the power with single-phase and 3 wire, (L, N) connect to the live wire of the power and zero line, and the PE should be connected.
- 6) Power supply requirement:

Main power voltage: $\pm 10\%$

Main power frequency: $\pm 2\%$

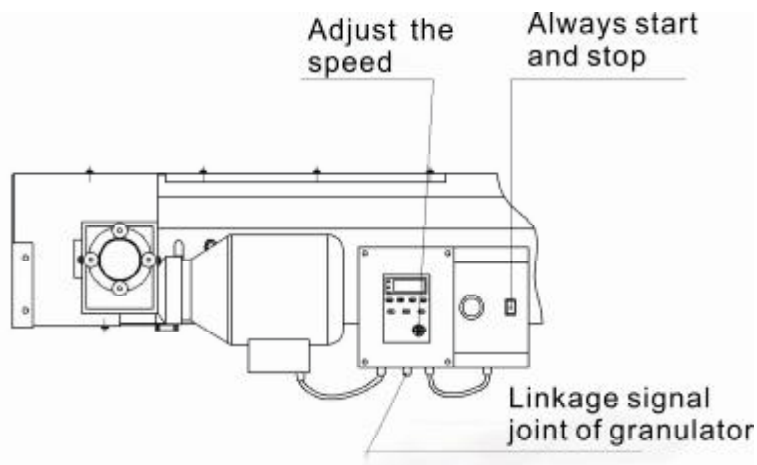

Picture 3-2: Power Connections

**Attention!**

1. After the power connected, check the direction of the motor rotation, if the motor reverses, the changing of running direction, please refer to parameter F-04 and F-05.
2. When belt conveyor requires to control the start/stop independently (without coordinated control of granulator), The switching of speed-regulator control mode, please refer to parameter F-03.
3. The detailed information about speed-regulator parameters and setting method, please refer to the Operation in Chapter 4.



Picture 3-3: Machine Installation Drawing

4. Use and operation

4.1 Operation instructions

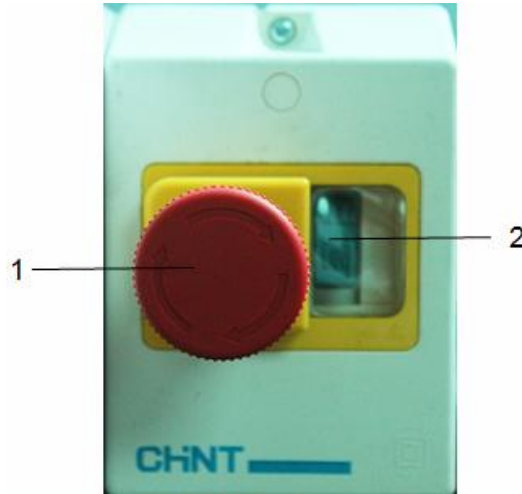

No.	Name	Function Description	Remark and Notice
1	Emergency stop button	Cut off power supply	Press the button, then according the arrow to rotate the button clockwise and reset it.
2	Start button	Turn on power supply	

- 1) Power on the control box of conveyor belt;
- 2) Press the start button and power on;
- 3) Press FWD button, and the conveyor belt runs forward;
- 4) Press STOP button, and the conveyor belt stops running;
- 5) Press REV button, the conveyor belt runs reversely (Default: The reverse running is forbidden. If it needs changing, please refer to parameter F-04).
- 6) Under emergency situation, press emergency stop button to cut off the power supply, the conveyor belt stops running.
- 7) Adjust the speed button of the speed regulator to change the speed of the conveyor belt.



The normal use and safety adjusting range is 3~6m/min (the corresponding speed adjusting panel graduation is 4.5~10).



No.	Name	Function Description	Remark and Notice
1	Forward Running indicator	It displays the forward state of the belt.	Red light on means running state. Red light off means stop state.
2	Reverse Running indicator	It displays the reverse state of the belt.	Red light on means running state. Red light off means stop state.
3	Stop indicator	It displays the stop state of the belt.	Red light on means running state. Red light off means stop state.
4	Mode key	Enter or exit the parameter setting mode	
5	Decrease key	Decrease the parameter	
6	Reverse Running key	Confirm reverse running of the belt.	At stop state, press the belt Reverse Running key.
7	Stop key	Control the machine stop.	At running state, press the Stop key.
8	Motor speed display area	Display motor speed	
9	Enter key	Confirm input value	
10	Increase key	Display actual regen. temp. or parameter code or parameter code	When drying heater is optional, it displays drying temp.
11	Forward running key	Confirm forward running of the belt.	At stop state, press the belt forward running key.
12	Speed adjusting button	Adjust the running speed of the belt.	

4.2 Main Parameter List of the Speed Regulator

Code	Parameter Function	Setting Range	Function Description	Default	Setting Value
F-01	Display content	1.Motor speed value 2.Rate speed value	Rate speed value=motor speed value÷rate	1	
F-02	Rate setting	1.0~999.9	Rate	1.0	
F-03	Running control mode	1. Operation panel 2.External terminal, panel STOP key is invalid 3. External terminal, panel STOP key is valid.	When operation panel is selected, the motor is controlled by the panel key. When external terminal is selected, the motor is controlled by the FWD, REV external switch K1, K2.	1	3
F-04	Running mode	1.Permit forward and reverse running 2.Permit forward running, forbid reverse running 3.Permit reverse running, forbid forward running	Restrict motor running direction to prevent malfunction or accident.	1	2
F-05	Running direction	1.No reverse running 2.With reverse running	Without changing of motor connection, it can easily change motor rotation to make it conform to custom or requirement.	1	2
F-06	Speed adjusting method	1.Panel ▲▼key 2.Panel button	Press ▲▼key within the min. and max. speed range, and adjust the button on motor speed panel to match 0~max. speed automatically.	1	2
F-07	Max. speed	500~3000	Restrict motor max. speed to prevent over speed, damage or accident.	1400	
F-08	Min. speed	120~1000	Restrict motor min. speed to prevent motor unstable speed, overheat or overload resulting from motor low speed.	150	
F-09	Acceleration time of forward start running	0.0~3.0 secs.	Long time, motor start slowly in long time; Short time, motor start swiftly in short time;	0.0	
F-10	Forward running stop method	1.Free deceleration stop 2.Slow deceleration stop	When selecting free deceleration stop, the motor stops swiftly. When selecting slow deceleration stop, change F-11 value, change the speed of slow deceleration stop.	1	

F-11	Slow deceleration time when forward running stops	0.0~3.0 secs.	When F-10 selecting 2 hours, the menu is valid.	1.0	
F-12	Acceleration time of reverse running start	0.0~3.0 secs.	Long time, motor start slowly in long time; Short time, motor start swiftly in short time;	0.0	
F-13	Reverse running stop method	1. Free deceleration stop 2. Slow deceleration stop	When selecting free deceleration stop, the motor stops swiftly. When selecting slow deceleration stop, change F-14 value, change the speed of slow deceleration stop.	1	
F-14	Slow deceleration time when reverse running stops	0.0~3.0 secs.	When F-13 selecting 2 hours, the menu is valid.	1.0	
F-29	Factory reset	1.No reset 2.Factory reset		1	
F-30	Program version	Code +version		01.10	

Fault alarm: Err-1: 1) Overload is block

2) Speed regulator is disconnected with motor or working capacitance.

Trouble-shooting: 1) Check and repair. 2) Re-connect and release the alarm.

5. Trouble Shooting

Failures	Solutions
Connect the power, rotate the motor protector knob and turn on the RUN / STOP switch of the speed regulator, the motor doesn't run.	<ol style="list-style-type: none">1. Check the speed regulator to see if the knob is pointing to 0, if so, adjust the speed knob.2. Check the circuit according to wiring diagram, the possible reasons can be as follows:<ol style="list-style-type: none">a: The power is failure.b: The circuit is disconnected.c: The motor protector is damaged.d: The motor is failure.
The circuit breaker often trips off.	Check the circuit according to wiring diagram, the possible reasons can be as follows: <ol style="list-style-type: none">a: The setting value of the breaker was too low, adjust the value to 1.1 times of the current one.b: Short circuit may exist.c: The motor protector is damaged.d: The motor is failure.

6. Service and Maintenance

Check whether there is oil leakage of the gear motor. Period: Daily
The lubricate oil in the gears box should be replaced after it has been run 400hr at the beginning, and after that the oil replacing periods is about 4,000hr. The lubricate oil in the gear motor must be sufficient. Replenishment or renewal must be done when there is oil leakage or lube degeneration. Period: Monthly

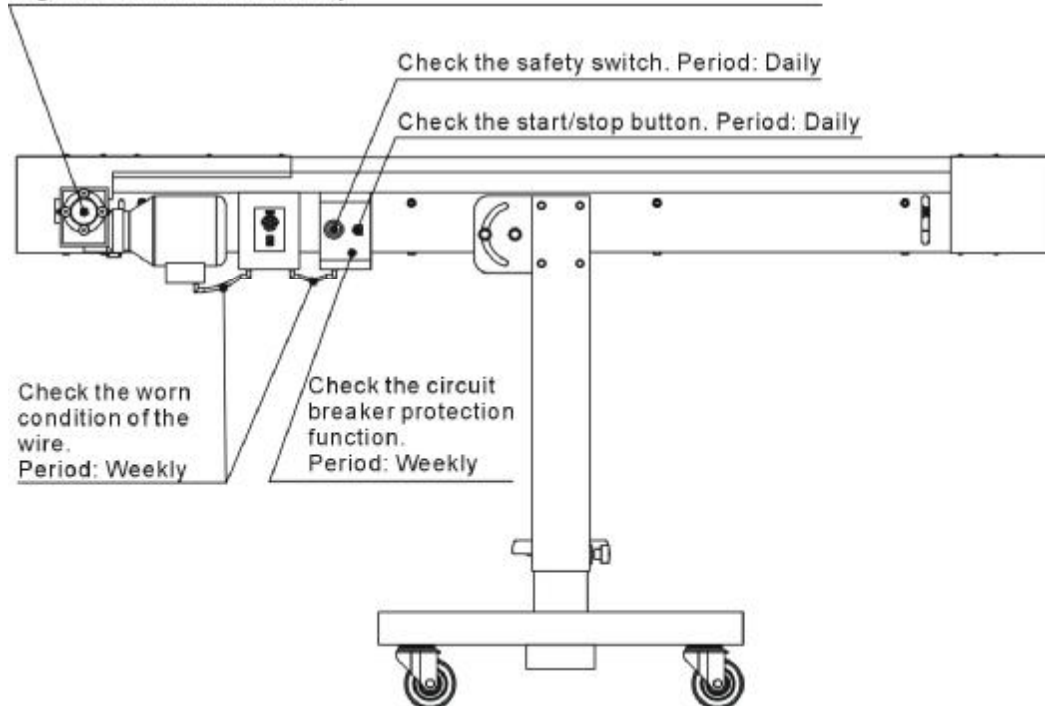

6.1 Repair

To avoid any body injury and damage of the machine, all of the repair work should be done by professional person only.

It is the duty of the operator to keep the machine clean from foreign matter, such as deposits, oil, or other materials. So it is necessary to clean the machine at the end of every working shift. This must be performed when the machine is stopped, in stable starting of the machine.

6.2 Maintenance

6.2.1 Maintenance of the Gear Motor

Check if the reduced gears box is oil leaking and it should be examined periodicity. When you find that the oil is reduced or the colour of it changed dark and black, you must complement it or replace it immediately. Please be noticed that keep the surface of the gear motor cleaning. Move away the dust and the

contamination in time so as to keep a good distribute of the heat.



Picture 6-1: Gear Motor



Danger!

Operating temperature range of gear motor is: 20°C-60°C.

6.2.2 Clearance of the Machine

Please keep the machine clean from foreign matter, such as deposits, oil, or other materials. Do the cleanly work everyday.



It is forbidden to use flammable liquids during the cleaning operation. Periodically check the status of the PU belt, and replace it, if necessary. Once the machine has been cleaned, the operator must check for worn out or damaged parts (in which case, he must replace it immediately), or for parts which are not firmly fixed (in which case, he should fix them, if this is possible).



The machine protection and safety devices must not be removed, unless a specific repair and/or maintenance action is required. These protections must be put back as soon as the reason for their removal has disappeared, in any case, they must be installed before starting the machine.



If using compressed air, the operator must wear safety glasses, and make sure that nobody is near the machine, because they may be hit by materials and dust.

6.2.3 Lubricate the Bearing

On a monthly basis lubricate the two supporters near the unloading area of the conveyor, below the protection cover, as indicated by the drawing.

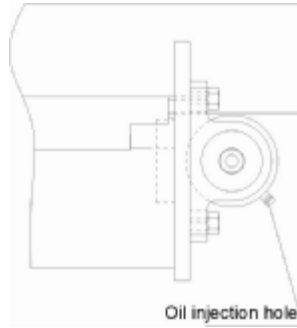

Picture 6-2: Bearing Lubricate Brawing



Stop the machine and unplug the power supply before doing the repair or maintenance work.

6.3 Adjusting the Central Position of the PU Belt

Rotate this nut to adjust the central space of the PU Belt

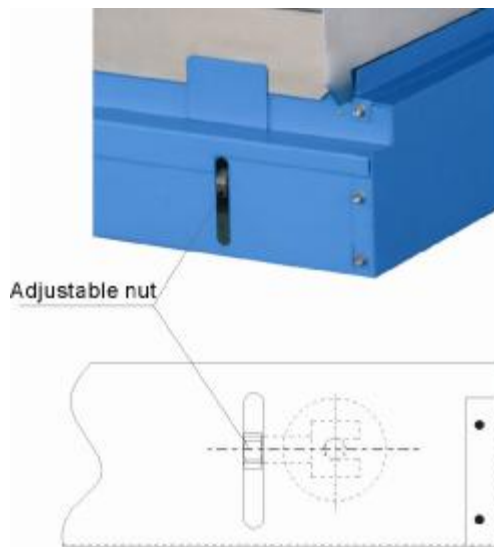

Picture 6-3: PVC Adjusting Drawing



Danger!

To check the proper centering it is necessary to make the machine run. However, the adjustment must be done when the machine is stopped, and then the belt must be made to run only for the time necessary to verify its proper centering.



Attention!

On a monthly basis verify that the external temperature of the motor and gearbox is not too high (it should be between 60 and 20°C). In case it is different, contact the technicians at SHINI directly.



Attention!

- 1) The maximum weight of the pieces to be carried on the conveyor belt must not be over 56kg in total(Conveying capacity is less than 56kg as the set value of the regulator is smaller than 4.5m/min)..
- 2) Not suitable to transport loose material.
- 3) PVC soft point temperature 80°C。



The operator, or the maintenance technician, must wear suitable work clothes, without free parts. They must not wear chains, bracelets, or other objects which may be caught by mechanical parts in movement. In case of long hair, special hairnets must be used, to avoid the risk of being caught.

6.4 Maintenance Schedule

6.4.1 About the Machine

Model _____ SN _____ Manufacture date _____

Voltage _____ Φ _____ V Frequency _____ Hz Power _____ kW

6.4.2 Check After Installation

- Check if the body of the machine installed horizontal
- Check for eventual leaks of lubricant from the reduction gear
- Check the status about the PU belt

Electrical installation

- Voltage _____ V _____ Hz
- Check if the power connection of the control box is correctly

6.4.3 Daily Checking

- Check the switches of the machine.
- Check if the reduction gears is oil leaking leaking.
- Check the function of the safety switch.

6.4.4 Weekly Checking

- Check all the electrical wires.
- Check the protection function of the breaker.