

SAC Belt Conveyor

User Manual

Date: Apr. 2021

Version: A (English)



Contents

1. General Description	5
1.1 Coding Principle.....	6
1.2 Features.....	6
1.3 Technical Specifications	8
1.3.1 SAC Specification.....	8
1.4 Safety Regulations.....	9
1.5 Exemption Clause.....	12
2. Structure Characteristics and Working Principle	13
2.1 Function Description	13
3. Installation and Debugging.....	14
3.1 Horizontal Installation.....	14
3.2 Power Connections.....	14
3.3 Expansion Diagram.....	16
3.4 Belt Regulation Method.....	18
4. Operation.....	19
4.1 Belt Conveyor Adjustment	19
4.2 Adjustment of the Conveyor's Inclination	19
4.3 Belt Position Adjustment	20
5. Trouble-shooting	22
6. Repair and Maintenance	23
6.1 Repair	23
6.2 Maintenance	23
6.2.1 Maintenance of the Gear Motor	23
6.2.2 Clearance of the Machine.....	24
6.3 Maintenance Schedule	25
6.3.1 General Machine Information	25
6.3.2 Installation & Inspection.....	25
6.3.3 Daily Checking	25
6.3.4 Weekly Checking.....	25

Table Index

Table 1-1: SAC Specification	8
Table 5-1: Trouble-shooting Specification 1	22
Table 5-2: Trouble-shooting Specification 2.....	22

Picture Index

Picture 1-1: Belt Conveyor SAC-400W	5
Picture 1-2: SAC Specification.....	8
Picture 2-1: Working Principle.....	13
Picture 3-1: Installation Diagram.....	14
Picture 3-2: Power Connections	15
Picture 3-3: Wing Screw Position Diagram	17
Picture 3-4: Belt Regulation Diagram.....	18
Picture 3-5: Diagram of M8 Long Screw on the End Face.....	18
Picture 4-1: Connecting Rod Diagram	19
Picture 4-2: Conveyor Adjustment	19
Picture 4-3: Belt Position Adjustment.....	20
Picture 6-1: Gear motor	24

1. General Description



Please read this manual carefully before using this machine in order to operate correctly against any damage caused due to improper operation



Picture 1-1: Belt Conveyor SAC-400W

1.1 Coding Principle

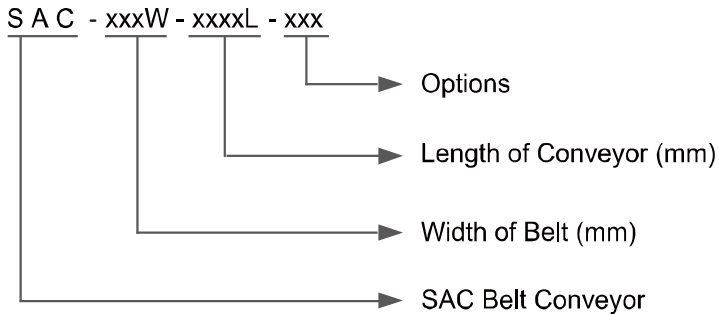

1.2 Features

- Employ high precision aluminum alloy profile, elegant appearance.
- The belt is made of high quality PVC material, improve the appearance and wearable;
- Traditional screw rods collocated with hand wheel in ascend and descend mode is integrated into the floor stand, which can adjust the height according to needs, and the compact size is made easy for assembly and storage;
- Control speed through hidden knob speed governor, easily and conveniently;
- With automatic and manual function, working with robot or independently;
- Trapezoidal flat belt pulley and idler pulley can effectively prevent the flat belt deviation;
- The max. load is 20kg;
- The standard variable speed control, under regular usage, has the safe speed regulation range from 3~6 m/min;

All service work should be carried out by a person with technical training or corresponding professional experience. The manual contains instructions for both handling and servicing. Chapter 6, which contains service instructions intended for service engineers. Other chapters contain instructions for the daily operator.

Any modifications of the machine must be approved by SHINI in order to avoid personal injury and damage to machine. We shall not be liable for any damage caused by unauthorized change of the machine.

Our company provides excellent after-sales service. Should you have any problem during using the machine, please contact the company or the local vendor.

Service Hotline:

Shini Hotline Service:

Headquarter and Taipei factory:

Tel: + 886 (0)2 2680 9119

Shini Plastics Technologies (Dongguan), Inc.:

Tel: +86 (0)769 8331 3588

Shini Plastics Technologies (Pinghu), Inc.:

Tel: +86 (0)573 8522 5288

Shinden Precision Machinery (Chongqing), Inc.:

+86 (0)23 6431 0898

1.3 Technical Specifications

1.3.1 SAC Specification

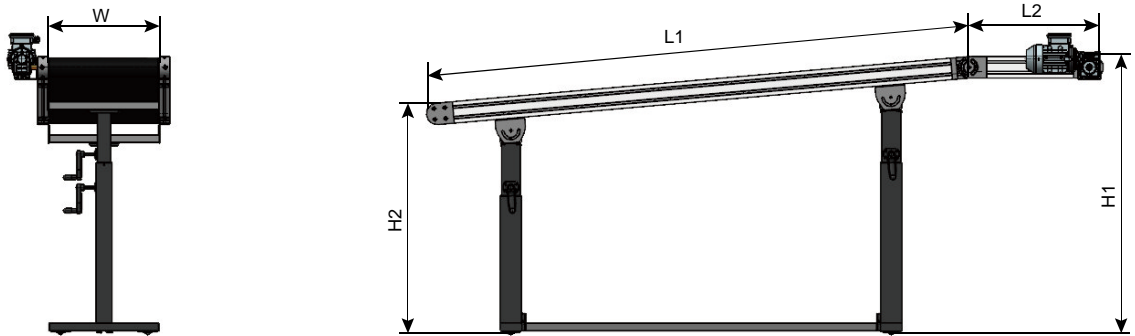

Picture 1-2: SAC Specification

Table 1-1: SAC Specification

Model	SAC-200W	SAC-300W	SAC-400W	SAC-500W	SAC-600W
Width of Belt W(mm)	200	300	400	500	600
Length of Horizontal Plane L2 (mm)	400/500/600				
Total Length L1+L2 (mm)	2500/3500/4000/4500			5500/6500	
Height of Higher End H1(mm)	1000~1500				
Height of Lower End H2 (mm)	900~1200				
Max Loading (with fixture) (Kg)	20(Uniform)				
Standard Speed (m/min)	2~6				
Belt Description	Material: PVC / Thickness: 2mm/Color: Black Rating of Temperature:-10°C~+80°C				
Motor Rated Power (KW)	0.09			0.25	
Power	3Φ400V AC 50/60Hz				

We reserve the right to change specifications without prior notice.

1.4 Safety Regulations

Pay attention to this Safety Regulations to prevent personnel injuries and machine damages.

It must observe the following safety regulations before machine operation.



All electrical components should be installed by qualified electricians.

Turn off main switch and control switch during repair and maintenance.



Warning!

The sound level produced by the machine is $\leq 70\text{dB}$ (max.) at the position of the operator.



Notice!

Noise level test refers to the following conditions: 1m around the machine, 1.6m above the machine.



Caution!

Don't use the machine and don't try to repair it before carefully read this manual and understood all its parts completely.

In particular, it is important to adopt the precaution listed in section a:'safety instruction';

It is forbidden to use the machine in any condition or for any use different from what is indicated in the manual.

SHINI has no responsibility for breakdowns, trouble, or injuries caused by improper operation.



Attention!

No need for regular inspection because all the electrical parts in the control unit are fixed tightly!



Attention!

The maximum weight of the pieces to be carried on the conveyor belt must not be over 20kg in total (Conveying capacity is less than 20kg as the set value of the regulator is smaller than 4.5m/min).

The conveyor belts are not suitable to transport loose material.



Attention!

These conveyor belts can be easily used by all of the personnel of the plant they are installed in, and they do not present any risk for the operator, if used properly.

Therefore, it is recommended to read the manual carefully before using the machine.



Attention!

SHINI claims no responsibility when:

- 1) Use of the conveyor belt is in any way openly opposed to what is indicated in the present instruction manual.
- 2) There is a serious deficiency of the foreseen maintenance.
- 3) Non-authorized changes are adopted.
- 4) Spare parts that are non-authorized or not suitable for the actual model are used.



Danger!

Risk of fire: Risk of fire is present whenever the conditions of the conveyor belts are not suitable for the operation they are used for (in particular: temperature of the pieces carried).



Risks of high temperature: These conveyor belts are designed for transporting molded parts, i.e. hot pieces. If you need to operate on the conveyor belt, use safety gloves (in particular where the parts fall on the belt);



Attention!

The packing material must not be left around, and it must be disposed of according to the regulations in force. It is possible to lift the conveyors with a fork lift.



Danger!

To protect the operator's safety, and the integrity of the machine, assure the stable lifting of the conveyor. Once the conveyor belt is running, it is necessary to fix the machine by locking the castors. Moreover, suitable slings or fixtures must be attached, to keep it steady during transportation.

1.5 Exemption Clause

The following statements clarify the responsibilities and regulations born by any buyer or user who purchases products and accessories from Shini (including employees and agents).

Shini is exempted from liability for any costs, fees, claims and losses caused by reasons below:

1. Any careless or man-made installations, operation and maintenances upon machines without referring to the Manual prior to machine using.
2. Any incidents beyond human reasonable controls, which include man-made vicious or deliberate damages or abnormal power, and machine faults caused by irresistible natural disasters including fire, flood, storm and earthquake.
3. Any operational actions that are not authorized by Shini upon machine, including adding or replacing accessories, dismantling, delivering or repairing.
4. Employing consumables or oil media that are not appointed by Shini.

2. Structure Characteristics and Working Principle

2.1 Function Description

SAC series belt conveyor can be connected with ST3 series or ST5 series or used as an assembly conveying line, and the angle can be adjusted according to customer's demands to ensure stable performance and convenient operation.

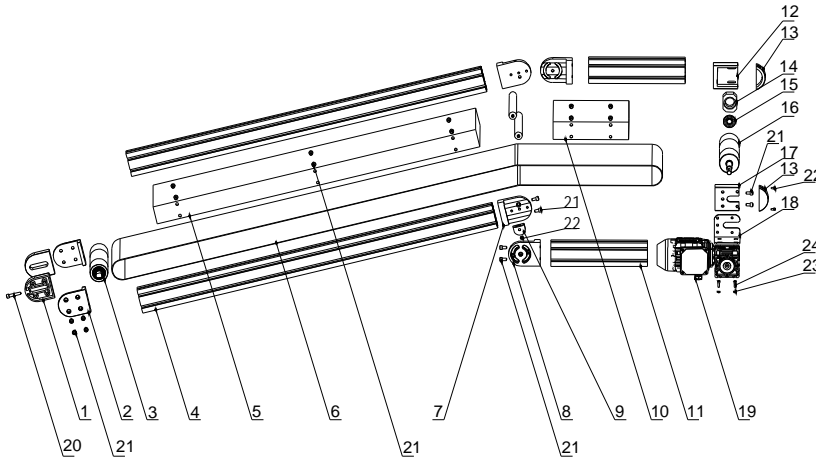

- | | | |
|-------------------------------------|------------------------------------|-------------------------------------|
| 1.Driven part | 2.Driven part | 3.Driven roller |
| 4.Plane guide rail | 5.Electrolytic plate | 6.Belt |
| 7.Semicircle inner alu. seat | 8.Semicircle ext. alu. Seat | 9. Adjusting plate |
| 10.Electrolytic plate | 11. Inclined guide rail | 12.Driving roller right alu. bottom |
| 13.Driving roller alu. bottom cover | 14. Bearing socket | 15. Self-aligning bearing |
| 16.Driving roller | 17.Driving roller left alu. bottom | 18.Motor plate |
| 19.Motor | | |

Picture 2-1: Working Principle

The conveyor belts of this series are made up of:

Equipped with a 4 swivel castors and the locking facility base, the conveyor belt can be easily moved to the working area. The driving roller (16) is directly connected to the motor (19) at the end. Equipped with stepless speed governor, the conveying speed can be adjusted and the belt center position and tightness can be changed by adjusting the M8 screw on the end face (13). Moreover, the belt conveyor is connected to the floor stand, so it is possible to change its inclination by adjusting the height through external rods on the floor stand.

Generally, the operator stands at the conveyor top end (discharging area). The controlling parts are located here as well.

3. Installation and Debugging

Read this chapter carefully before installation, Must observe the installation steps as follows!

This series of models are used in a well ventilated working environment.



The connection of the power supply should be done by qualified electricians only!

3.1 Horizontal Installation

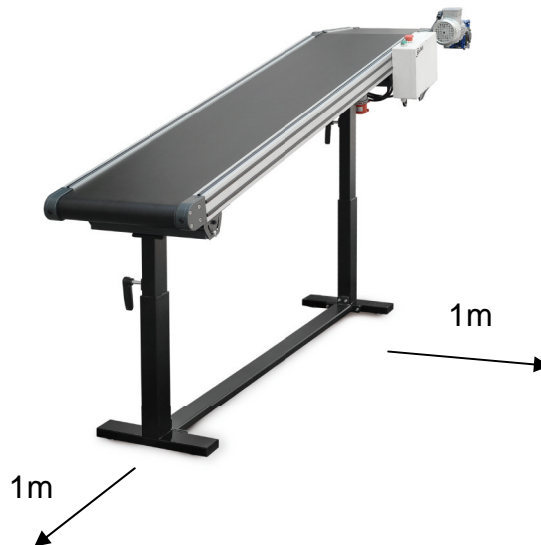

Picture 3-1: Installation Diagram

Note: Keep the machine 1m away from inflammables.

Conveyors don't require any particular preliminary operation before starting-up.

With reference to the layout of the cables, make sure that they are protected against damage and that they don't hamper the operators.

3.2 Power Connections

The wire of the inclined belt conveyor, speed regulator and motor protector should be connected strictly comply with the wiring diagram.

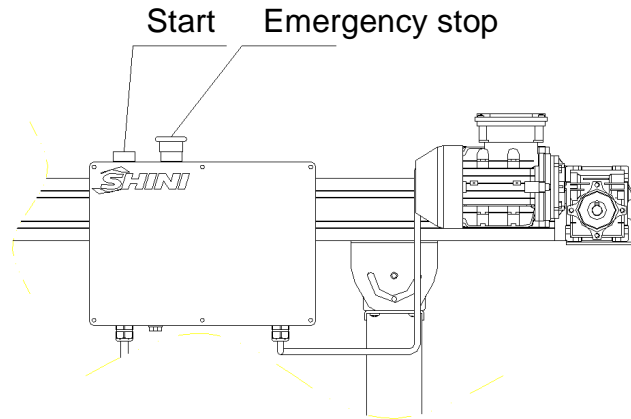

Picture 3-2: Power Connections

- 5) Verify that the power supply corresponds to the specifications of the plate near the controls of the conveyor.
- 6) Connect the power cable and the PE wire according to the local regulations.
- 7) Use independent power cable and switch, Make sure that the diameter of the cable is not smaller than the cable used in the control box.
- 8) The connection end of the power cable should be safely and tightly.
- 9) This series use the power with single phase and 3 wires, (L) connect to the live wire of the power, and the PE should be connected.
- 10) Power supply requirement:
Main power voltage: $380V \pm 10\%$
Main power frequency: $50Hz \pm 2\%$
- 7) ***Please refer to electrical drawing of each model to get the detailed power supply specifications.***

3.3 Expansion Diagram

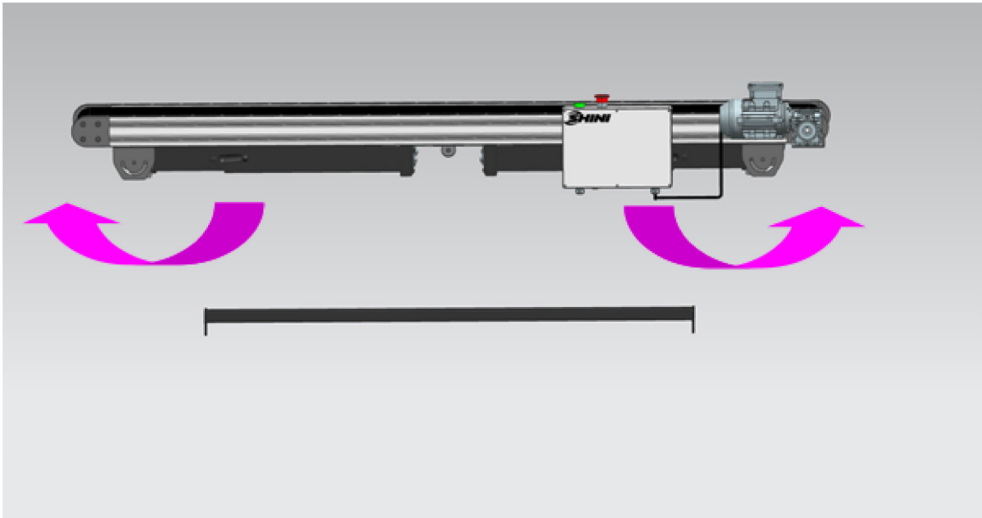

The 1st step: Take the belt conveyor out of the package and place it on the ground.

The 2nd step: Put the wood on the ground.

The 3rd step: Put the belt conveyor on the wood.

The 4th step: Open the floor stand to 90° degree.

The 5th step: Install the beam

The 6th step: Lock the wing screw.

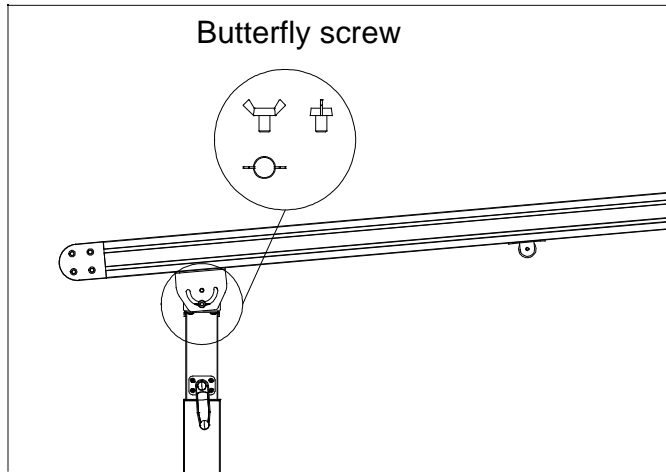

Picture 3-3: Wing Screw Position Diagram

3.4 Belt Regulation Method

If the belt deviates to the right, the roller will tighten the screws to the right in belt forward direction, or loosen the screws on the left, and so on.

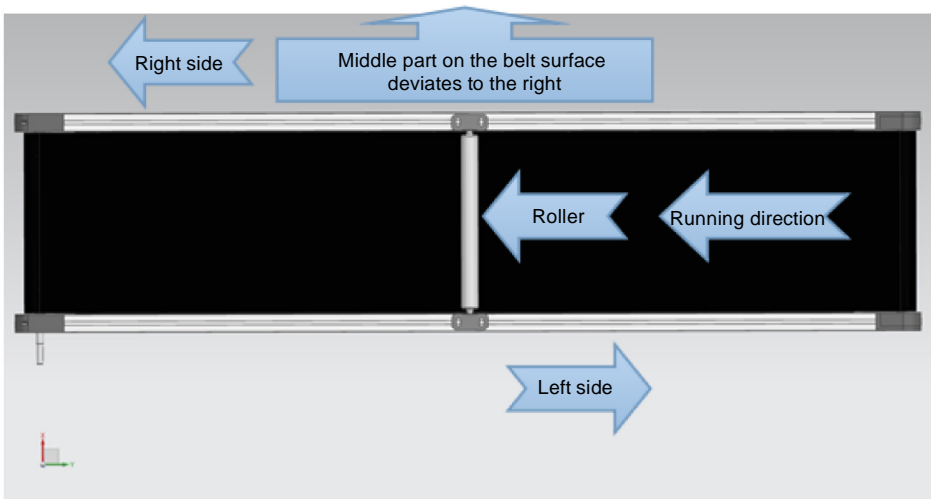
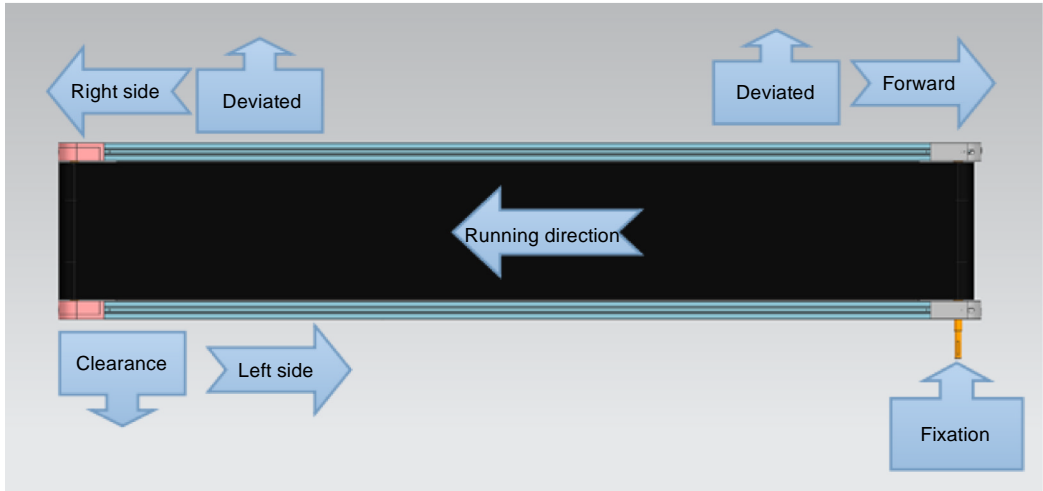

Picture 3-4: Belt Regulation Diagram

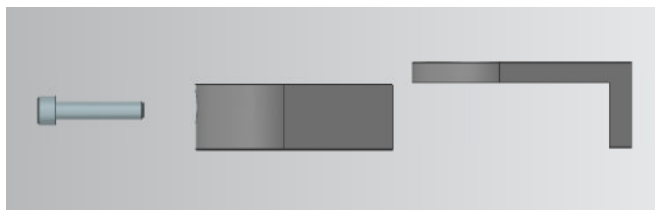

Picture 3-5: Diagram of M8 Long Screw on the End Face

4. Operation

4.1 Belt Conveyor Adjustment

Rotate the connecting rod, adjust the belt conveyor to the height on demand, and then tighten the wing screw.

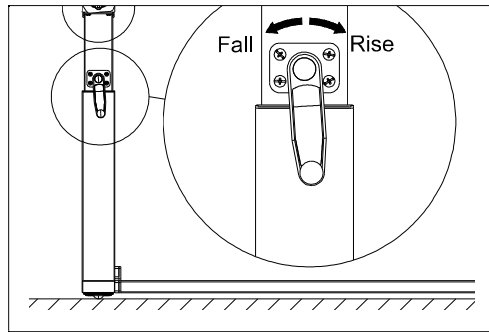

Picture 4-1: Connecting Rod Diagram

Note: Please lift hard or support the conveyor when adjusting the height to prevent personal or machine damage caused by dropping.

4.2 Adjustment of the Conveyor's Inclination

Loosen the locked wing screw, adjust the conveyor to the inclination on demand, and then lock the wing screw.

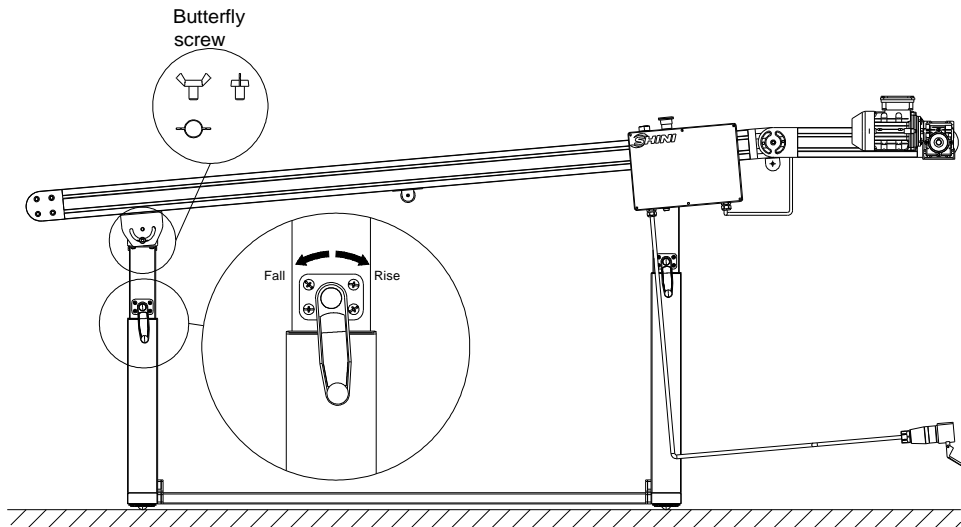

Picture 4-2: Conveyor Adjustment

Note: The machine's adjustable angle is 0°~25° !

4.3 Belt Position Adjustment

Rotate this screw to adjust the belt center position.

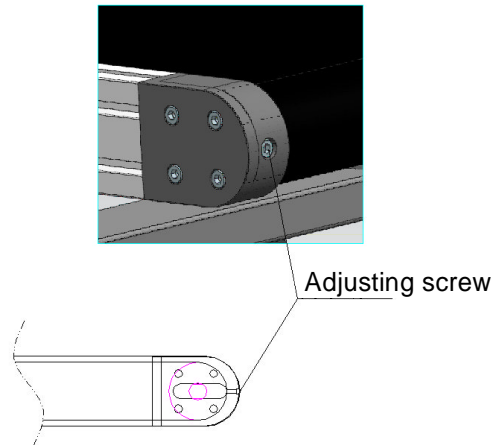

Picture 4-3: Belt Position Adjustment



Danger!

To check the proper centering it is necessary to make the machine run. However, the adjustment must be done when the machine is stopped, and then the belt must be made to run only for the time necessary to verify its proper centering.



Attention!

On a monthly basis verify that the external temperature of the motor and gearbox is not too high (it should be between 60 and 20°C). In case it is different, contact the technicians at SHINI directly.



Attention!

- 1) The maximum weight of the pieces to be carried on the conveyor belt must not be over 20kg in total.
- 2) Not suitable to transport loose material.
- 3) The maximum resistant temperature of PU belt is 120°C.



The operator, or the maintenance technician, must wear suitable work clothes, without free parts. They must not wear chains, bracelets, or other objects which may be caught by mechanical parts in movement. In case of long hair, special hairnets must be used, to avoid the risk of being caught.

5. Trouble-shooting

Table 5-1: Trouble-shooting Specification 1

Failures	Solutions
Connect the power, rotate the motor protector knob and turn on the RUN / STOP switch of the speed regulator, the motor doesn't run.	1. Check the circuit according to wiring diagram, the possible reasons can be as follows: a: The power is failure. b: The circuit is disconnected. c: The motor protector is damaged. d: The motor is failure. Check the cause, repair the circuit and replace the broken electrical components.
The circuit breaker often trips off.	Check the circuit according to wiring diagram, the possible reasons can be as follows: a: The setting value of the breaker was too low, adjust the value; b: Short circuit may exist. c: The motor protector is damaged. d: The motor is failure. e: If the setting value of stepless speed governor is too small, adjust the value;

Table 5-2: Trouble-shooting Specification 2

No.	Type	Symptom	Reasons	Solutions
1	Belt deviation and edging	Belt deviated, and wear of belt edge after operation	Uncorrected frame and roller	Recalibrate the position and remove the surface cohesive materials.
2	Belt slip	Belt slip, and it doesn't run	Small roller and belt friction coefficient, and too loose of the tensioning device.	Increase the friction coefficient and tighten the screws
3	Roller doesn't run	Roller doesn't run or inflexible	Dirt and bearing damage	Keep the roller clean and replace the bearing or roller
4	Belt stuck Start difficulty	The belt can't start	Overload running	Reduce the load

6. Repair and Maintenance

Check whether the gear motor leaks lubricating oil.

Period: daily.

Check whether the gear of the gear motor leaks lubricating oil;

The lubricating oil must be replaced when it runs 400 hrs. from its initial start. After it, the oil replacing cycle is 4000 hrs., and it must leave enough lubricating oil inside the case of the gear motor, and check it regularly.

When the oil quantity is reduced or the oil quality turned bad, it must refill or replace the lubricating oil.

Period: monthly.

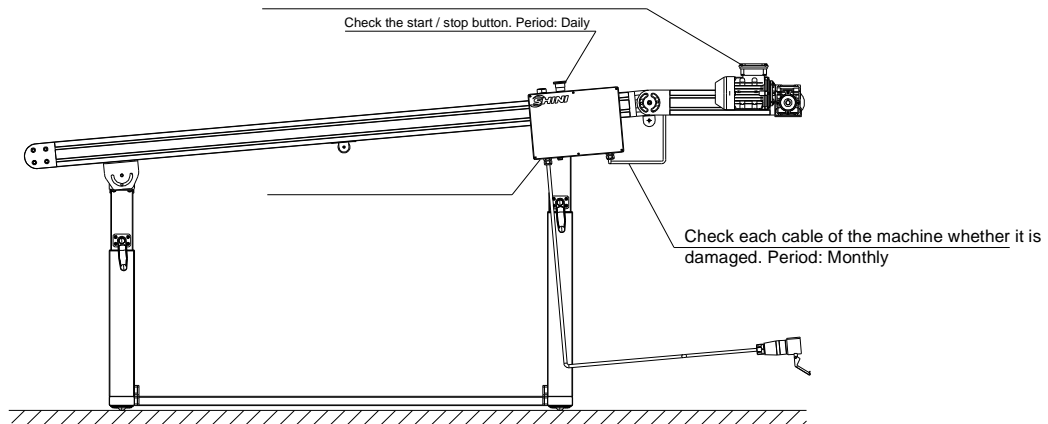

6.1 Repair

To avoid any body injury and damage of the machine, all of the repair work should be done by professional person only.

It is the duty of the operator to keep the machine clean from foreign matter, such as deposits, oil, or other materials.

So it is necessary to clean the machine at the end of every working shift.

This must be performed when the machine is stopped, in stable starting of the machine.

6.2 Maintenance

6.2.1 Maintenance of the Gear Motor

Check whether the gear of the gear motor leaks lubricating oil, and the lubricating oil must be replaced when it runs 400 hrs. from its initial start. After it, the oil replacing cycle is 4000 hrs., and it must leave enough lubricating oil inside the case of the gear motor, and check it regularly. When the oil quantity is reduced or the oil quality turned bad, it must refill or replace the lubricating oil.

Note: Keep the motor and gear motor clean, and remove the dust and dirt in time for good heat dissipation.

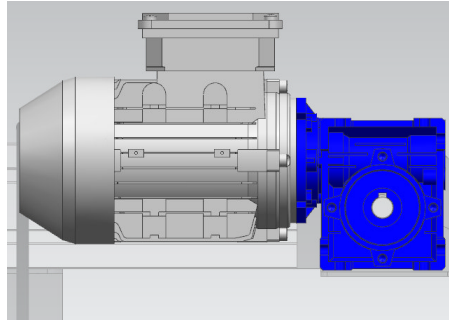

Picture 6-1 : Gear motor



Danger!

Operating temperature range of gear motor is: 20°C-60°C.

6.2.2 Clearance of the Machine

Please keep the machine clean from foreign matter, such as deposits, oil, or other materials. Do the cleanly work every day.



It is forbidden to use flammable liquids during the cleaning operation. Periodically check the status of the PU belt, and replace it, if necessary. Once the machine has been cleaned, the operator must check for worn out or damaged parts (in which case, he must replace it immediately), or for parts which are not firmly fixed (in which case, he should fix them, if this is possible).



The machine protection and safety devices must not be removed, unless a specific repair and/or maintenance action is required. These protections must be put back as soon as the reason for their removal has disappeared, in any case, they must be installed before starting the machine.



If using compressed air, the operator must wear safety glasses, and make sure that nobody is near the machine, because they may be hit by materials and dust.

6.3 Maintenance Schedule

6.3.1 General Machine Information

Model _____ SN _____ Manufacture date _____
Voltage _____ Φ _____ V Frequency _____ Hz Power _____ kW

6.3.2 Installation & Inspection

- Check whether the machine is installed horizontally.
- Check whether the gear motor leaks lubricating oil.
- Check the PVC belt condition

Electrical Installation

- Voltage _____ V _____ Hz
- Check whether the wiring of power in the control box is correct.

6.3.3 Daily Checking

- Check the start/stop button.
- Check whether the gear motor leaks lubricating oil.
- Check the PVC belt condition.
- Check the function of the safety switch.
- Check whether there's abnormal noise.

6.3.4 Weekly Checking

- Check all cables of the machine whether they are broken.
- Check the circuit breaker's protective function.
- Check whether the control box is normal.