

机型版本 Ver.A

| | | | | | | | | |
|----|-----|-----|-----|----|----|--|----|-----------|
| | | | | | 制图 | | 版号 | A |
| | | | | | 设计 | | 核准 | |
| | | | | | 校对 | | 核准 | |
| 标记 | 更改前 | 更改后 | 更改人 | 日期 | 审核 | | 日期 | 202312314 |

标题 SG-M18
电气原理图一

图号 SG-M18-GB-400V-A-1



信易电热机械股份有限公司
Shini Plastics Technologies, Inc.

| | | |
|------|--------|-------|
| 比例 | GB | 第 1 张 |
| 标准 | | 共 3 张 |
| 机器电压 | 3φ400V | |
| 机器频率 | 50Hz | |

1 2 3 4 5 6 7 8

1/PE/230V 50/60Hz

注：VR立即回收装置须单独接230V电源

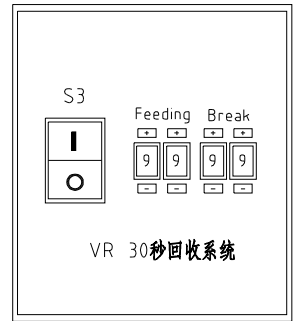
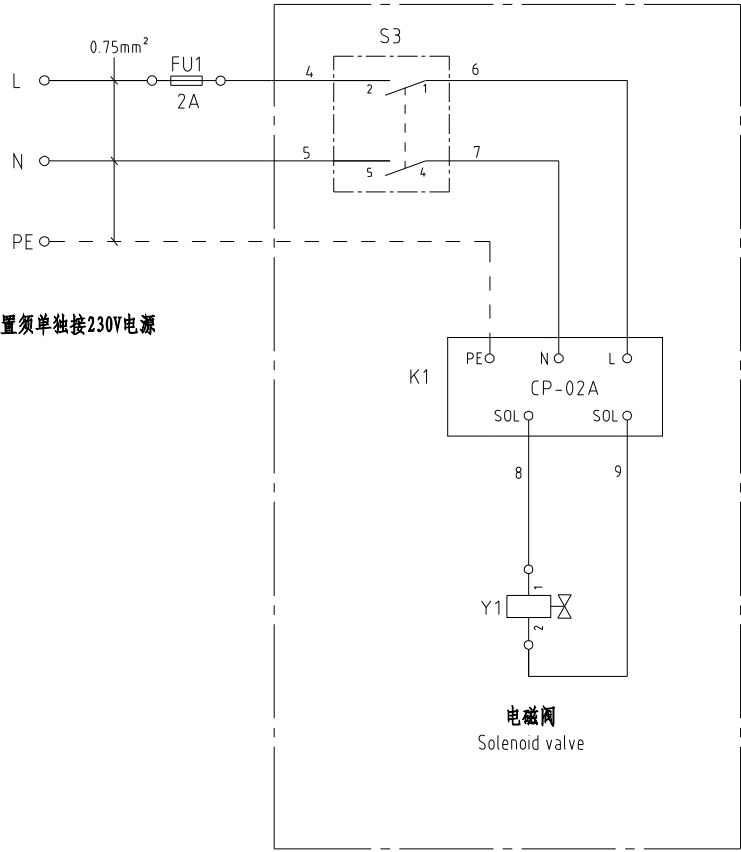

| | | | | | | | | | | | | | | | |
|-------------|-----|-------------|-----|----|----|----|-----------|---|-----------|------|-----------------------|------|--------|-------|--|
| 机型版本 Ver. A | | 选配VR立即回收装置。 | | | | 制图 | | 版号 A | 标题 SG-M18 | | 图号 SG-M18-GB-400V-A-2 | | 比例 | 第 2 张 | |
| | | | | | | 设计 | | 核准 | 电气原理图二 | | 标准 GB | | 共 3 张 | | |
| | | | | | | 校对 | | | | | 机器电压 | | 3φ400V | | |
| 标记 | 更改前 | 更改后 | 更改人 | 日期 | 审核 | 日期 | 202312314 | SHINI 信易电热机械股份有限公司 Shini Plastics Technologies, Inc. | | 机器频率 | | 50Hz | | | |
| 1 | 2 | 3 | 4 | 5 | 6 | 7 | 8 | | | | | | | | |

| 1 | | 2 | | 3 | | 4 | | 5 | | 6 | | 7 | | 8 | | |
|-------|------------|----------------------|---|------------------|-----------|---------|--------------|------------------|-----------------|---|-----------|---|---------------|-----------|--------|--|
| 序号/NO | 符号/Symbol | 名称/Name | | 制造商/Manufacturer | | 型号/Type | | 规格/Specification | | 单位/unit | 数量/Number | 物料编号/Material number | | 备注/Remark | | |
| A | 1 | Q1 | 热磁断路器/Circuit-breaker | | CHNT | | NS2-25 | | 4-6.3A | | PCS | 1 | YE40406300000 | | (1) | |
| | 2 | | 欠压脱扣器/Undervoltage release | | CHNT | | NS2-UV220 | | 220V | | PCS | 1 | YE40222000900 | | (1) | |
| | 3 | | 防水安装盒/Waterproof-box | | CHNT | | NS2-MC01 | | ---- | | PCS | 1 | YR40012000000 | | (1) | |
| | 4 | Q2 | 热磁断路器/Circuit-breaker | | CHNT | | NS2-25 | | 1.1-1.6A | | PCS | 1 | YE10011600000 | | (1)(2) | |
| | 5 | | 防水安装盒/Waterproof-box | | CHNT | | NS2-MC01 | | ---- | | PCS | 1 | YR40012000000 | | (1)(2) | |
| | 6 | S1 | 安全开关/Safety switch | | SCHMERSRC | | TEND/TZ-9212 | | AZ-15 | | PCS | 1 | YE16921200000 | | (1) | |
| | 7 | S2 | 切替开关/Safety switch | | ---- | | R210-C5LBW4P | | 10A 250V | | PCS | 1 | YE10210400000 | | (1)(3) | |
| B | 8 | K1 | VR拨码器/Time Dialer | | YUYUN | | CP-02A | | AC220V | | PCS | 1 | YE80222000600 | | (1)(3) | |
| | 9 | | 电线0.75*1C*200M红色 | | | | | | | | M | 3 | YE50750100000 | | (1) | |
| | 10 | | 端子1.25-4Y(1000PCS/包) | | | | | | | | PAC | 0.016 | YE60100440200 | | (1) | |
| | 11 | | 管形端子E1008 | | | | | | | | PCS | 8.000 | YE60100800200 | | (1) | |
| | 12 | | 电缆锁头PG9 | | | | | | | | PCS | 1 | YE67000940000 | | (1) | |
| | 13 | | 电缆线1.5*4C*1.1M | | | | | | | | BA | 1 | BE51150403250 | | (1) | |
| | 14 | | 电缆线1.5*5C*4M | | | | | | | | BA | 1 | BE51154700050 | | (1) | |
| | 15 | | 电线0.75*3C*4M(中性线(零线)使用蓝色) | | | | | | | | M | 4 | YE50050300100 | | (1) | |
| C | 16 | | 电缆线1.5*4C*1.1M | | | | | | | | BA | 1 | BE51150403250 | | (1)(2) | |
| | 17 | | 电线0.75*3C*4M(中性线(零线)使用蓝色) | | | | | | | | M | 4 | YE50050300100 | | (1)(3) | |
| | 1 | FU | 线型保险/Fuse Box | | SHINI | | ---- | | 2A | | PCS | 1 | YE46000200000 | | (3) | |
| | 18 | Y | 电磁阀/Solenoid valve | | AIRTAC | | ---- | | 4V210-08/AC220V | | PCS | 1 | ---- | | (3) | |
| | 19 | M1 | 粉碎电机/Granulating Motor | | SHIYUAN | | 2.2KW | | 400V 50Hz | | PCS | 1 | ----- | | (1) | |
| 20 | M2 | 吸料风机/Solution blower | | REXCHIP | | 0.55KW | | 400V 50Hz | | PCS | 1 | ----- | | (1)(2) | | |
| D | 机型版本 Ver.A | | 注：(1)表示非电控箱安装；(2)表示送料风机选配件；(3)选配VR立即回收装置。 | | | | | | | | | | | | | |
| | | | | | 制图 | | 版号 | A | 标题 | SG-M18 | 图号 | SG-M18-GB-400V-A-3 | | 比例 | 第 3 张 | |
| | | | | | 设计 | | 核准 | | 电气元件明细表 | | | | 标准 | GB | 共 3 张 | |
| | 标记 | 更改前 | 更改后 | 更改人 | 日期 | 审核 | | 日期 | 202312314 |  | | 信易电热机械股份有限公司 Shini Plastics Technologies, Inc. | | 机器电压 | 3φ400V | |
| | | | | | | | | | | | | | | 机器频率 | 50Hz | |
| 1 | | 2 | | 3 | | 4 | | 5 | | 6 | | 7 | | 8 | | |

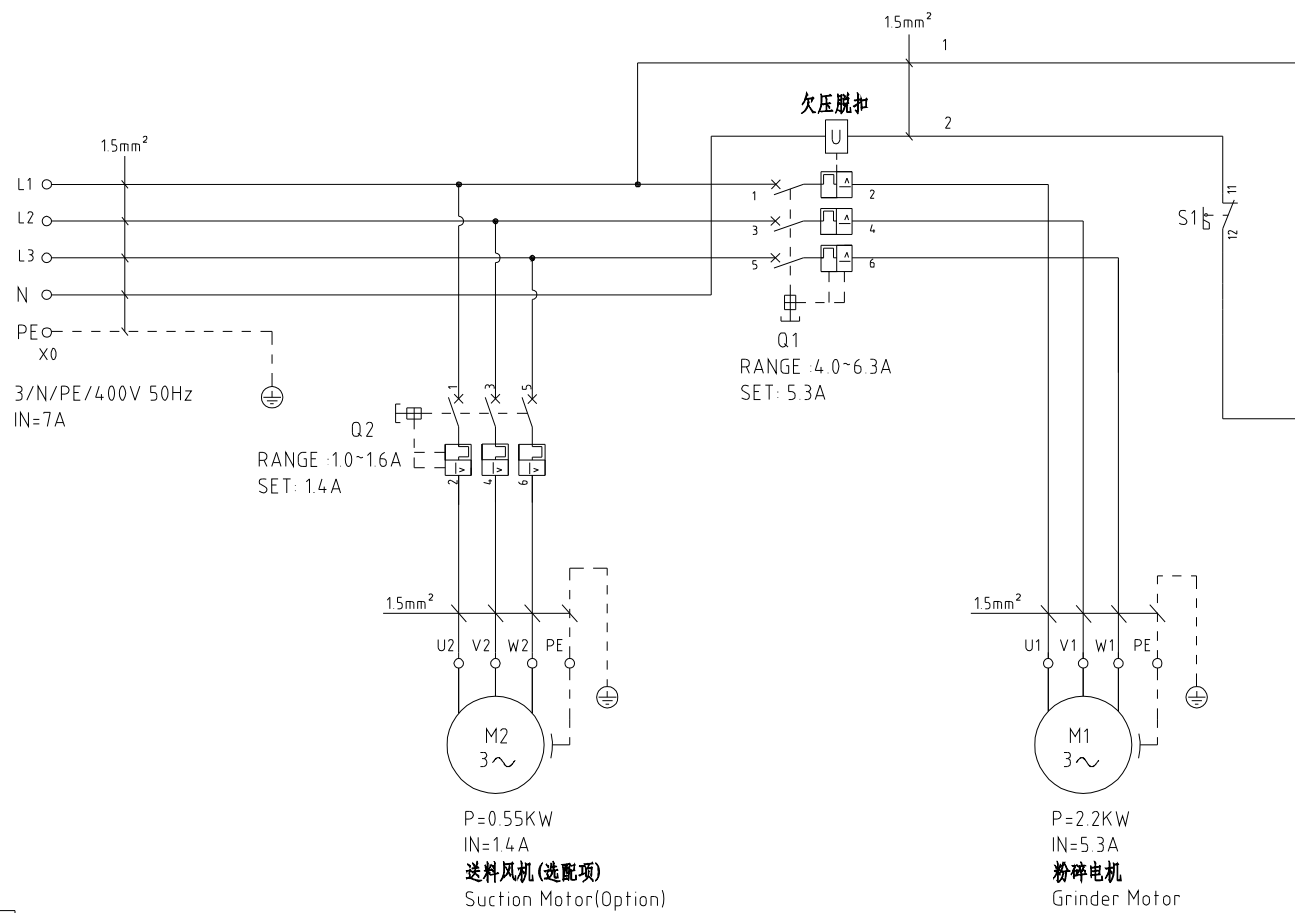

机型版本 Ver.A

| | | | | | | | | |
|----|-----|-----|-----|----|----|--|----|----------|
| | | | | | 制图 | | 版号 | 0 |
| | | | | | 设计 | | 核准 | |
| | | | | | 校对 | | 核准 | |
| 标记 | 更改前 | 更改后 | 更改人 | 日期 | 审核 | | 日期 | 20230529 |

标题 SG-M29
电气原理图一

图号 SG-M29-400V-0-1

| | |
|-------|-------|
| 比例 | 第 1 张 |
| 标准 GB | 共 3 张 |

SHINI 信易电热机械股份有限公司
Shini Plastics Technologies, Inc.

| | |
|------|--------|
| 机器电压 | 3φ400V |
| 机器频率 | 50Hz |

1 2 3 4 5 6 7 8

1 2 3 4 5 6 7 8

A

B

C

A

B

C

1/PE/230V 50/60Hz

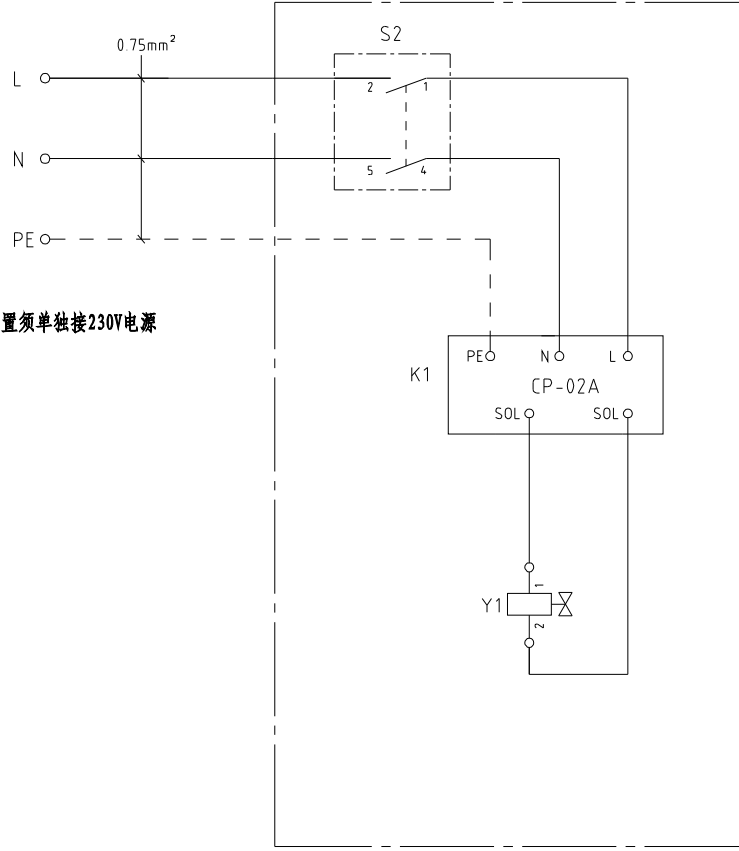

注：VR立即回收装置须单独接230V电源

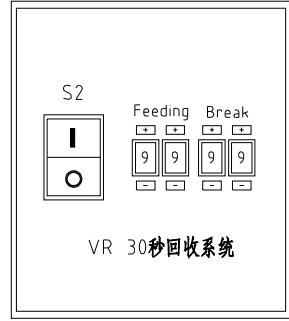

机型版本 Ver.A 选配VR立即回收装置。

| | | | | | | | | | | | |
|----|---|-----|---|--------|---|-----------------------------------|---|-------|--|--------|--|
| 制图 | | 版号 | | 标题 | | 图号 | | 比例 | | 第 2 张 | |
| 设计 | | 核准 | | SG-M29 | | SG-M29-400V-0-2 | | 标准 GB | | 共 3 张 | |
| 校对 | | 日期 | | 电气原理图二 | | 信易電熱機械股份有限公司 | | 机器电压 | | 3φ400V | |
| 标记 | | 更改后 | | 日期 | | Shini Plastics Technologies, Inc. | | 机器频率 | | 50Hz | |
| 1 | 2 | 3 | 4 | 5 | 6 | 7 | 8 | | | | |

1 2 3 4 5 6 7 8

| 1 | | 2 | | 3 | | 4 | | 5 | | 6 | | 7 | | 8 | |
|--|-----------|----------------------------|--|------------------|--|--------------|--|------------------|--|---|-----------|----------------------|--|-----------|--|
| 序号/NO | 符号/Symbol | 名称/Name | | 制造商/Manufacturer | | 型号/Type | | 规格/Specification | | 单位/unit | 数量/Number | 物料编号/Material number | | 备注/Remark | |
| 1 | Q1 | 热磁断路器/Circuit-breaker | | CHNT | | NS2-25 | | 4-6.3A | | PCS | 1 | YE40406300000 | | (1) | |
| 2 | | 欠压脱扣器/Undervoltage release | | CHNT | | NS2-UV220 | | 220V | | PCS | 1 | YE40222000900 | | (1) | |
| 3 | | 防水安装盒/Waterproof-box | | CHNT | | NS2-MC01 | | ---- | | PCS | 1 | YR40012000000 | | (1) | |
| 4 | Q2 | 热磁断路器/Circuit-breaker | | CHNT | | NS2-25 | | 1.1-1.6A | | PCS | 1 | YE10011600000 | | (1)(2) | |
| 5 | | 防水安装盒/Waterproof-box | | CHNT | | NS2-MC01 | | ---- | | PCS | 1 | YR40012000000 | | (1)(2) | |
| 6 | S1 | 安全开关/Safety switch | | SCHMERSRC | | TEND/TZ-9212 | | AZ-15 | | PCS | 1 | YE16921200000 | | (1) | |
| 7 | S2 | 切替开关/Safety switch | | ---- | | R210-C5LBW4P | | 10A 250V | | PCS | 1 | YE10210400000 | | (1)(3) | |
| 8 | K1 | VR拨码器/Time Dialer | | YUYUN | | CP-02A | | AC220V | | PCS | 1 | YE80222000600 | | (1)(3) | |
| 9 | | 电线0.75*1C*200M红色 | | | | | | | | M | 3 | YE50750100000 | | (1) | |
| 10 | | 端子1.25-4Y(1000PCS/包) | | | | | | | | PAC | 0.016 | YE60100440200 | | (1) | |
| 11 | | 管形端子E1008 | | | | | | | | PCS | 8.000 | YE60100800200 | | (1) | |
| 12 | | 电缆锁头PG9 | | | | | | | | PCS | 1 | YE67000940000 | | (1) | |
| 13 | | 电缆线1.5*4C*1.1M | | | | | | | | BA | 1 | BE51150403250 | | (1) | |
| 14 | | 电缆线1.5*5C*4M | | | | | | | | BA | 1 | BE51154700050 | | (1) | |
| 15 | | 电线0.75*3C*4M(中性线(零线)使用蓝色) | | | | | | | | M | 4 | YE50050300100 | | (1) | |
| 16 | | 电缆线1.5*4C*1.1M | | | | | | | | BA | 1 | BE51150403250 | | (1)(2) | |
| 17 | | 电线0.75*3C*4M(中性线(零线)使用蓝色) | | | | | | | | M | 4 | YE50050300100 | | (1)(3) | |
| 18 | Y | 电磁阀/Solenoid valve | | AIRTAC | | ---- | | 4V210-08/AC220V | | PCS | 1 | ---- | | (3) | |
| 19 | M1 | 粉碎电机/Granulating Motor | | SHIYUAN | | 2.2KW | | 400V 50Hz | | PCS | 1 | ----- | | (1) | |
| 20 | M2 | 吸料风机/Solution blower | | REXCHIP | | 0.55KW | | 400V 50Hz | | PCS | 1 | ----- | | (1)(2) | |
| 机型版本 Ver.A 注: (1)表示非电控箱安装; (2)表示送料风机选配件; (3)选配VR立即回收装置. | | | | | | | | | | | | | | | |
| 制图 | | 设计 | | 校对 | | 审核 | | 日期 | | 标题 | | 图号 | | 比例 | |
| | | | | | | 版号 | | 0 | | SG-M29 | | SG-M29-400V-0-3 | | 第 3 张 | |
| | | | | | | 核准 | | | | 电气元件明细表 | | | | 共 3 张 | |
| | | | | | | | | | |  信易電熱機械股份有限公司 Shini Plastics Technologies, Inc. | | 机器电压 | | 3φ400V | |
| 标记 | | 更改前 | | 更改后 | | 更改人 | | 日期 | | | | 20230529 | | 机器频率 | |
| 1 | | 2 | | 3 | | 4 | | 5 | | 6 | | 7 | | 8 | |

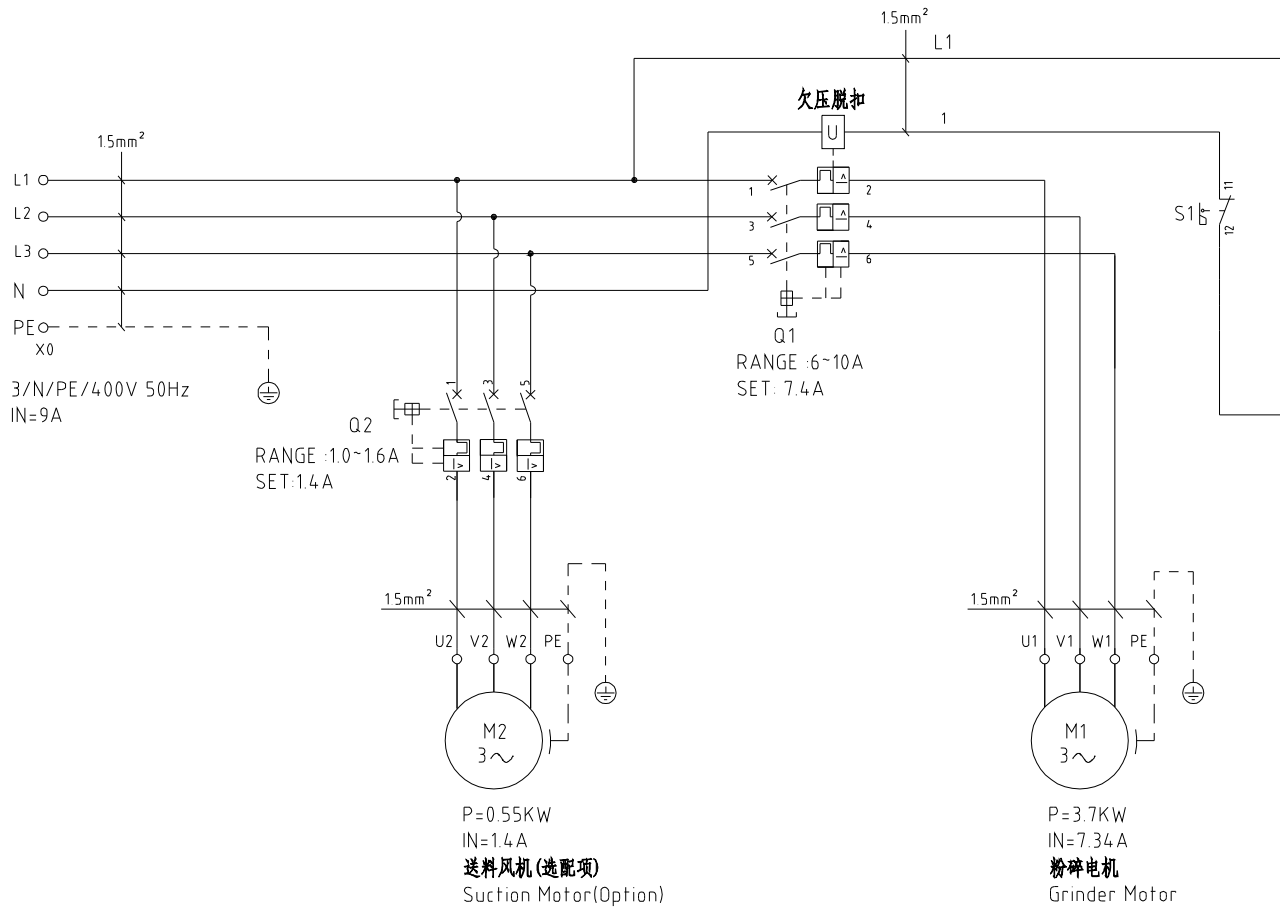

机型版本 Ver.A

| | | | | | | | | |
|----|-----|-----|-----|----|----|--|----|----------|
| | | | | | 制图 | | 版号 | 0 |
| | | | | | 设计 | | 核准 | |
| | | | | | 校对 | | 核准 | |
| 标记 | 更改前 | 更改后 | 更改人 | 日期 | 审核 | | 日期 | 20230831 |

标题 SG-M43
电气原理图

图号 SG-M43-400V-0-1



信易电热机械股份有限公司
Shini Plastics Technologies, Inc.

| | | |
|------|--------|-------|
| 比例 | GB | 第 1 张 |
| 标准 | | 共 3 张 |
| 机器电压 | 3φ400V | |
| 机器频率 | 50Hz | |

1 2 3 4 5 6 7 8

1 2 3 4 5 6 7 8

A

B

C

A

B

C

1/PE/230V 50/60Hz

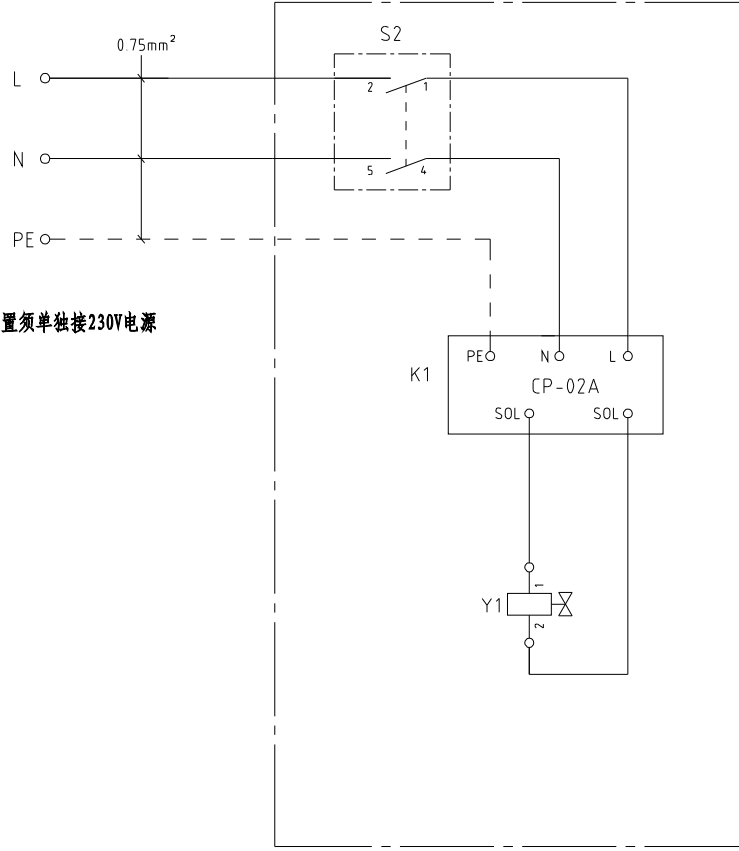

注：VR立即回收装置须单独接230V电源

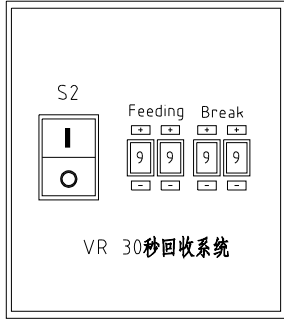

机型版本 Ver.A 选配VR立即回收装置。

| | | | | | | | | | | | |
|----|---|----|---|----------|---|---|---|-------|--|--------|--|
| 制图 | | 版号 | | 标题 | | 图号 | | 比例 | | 第 2 张 | |
| 设计 | | 0 | | SG-M43 | | SG-M43-400V-0-2 | | 标准 GB | | 共 3 张 | |
| 校对 | | 核准 | | 电气元件明细表 | | SHINI 信易電熱機械股份有限公司 Shini Plastics Technologies, Inc. | | 机器电压 | | 3φ400V | |
| 标记 | | 日期 | | 20230831 | | | | 机器频率 | | 50Hz | |
| 1 | 2 | 3 | 4 | 5 | 6 | 7 | 8 | | | | |

| 1 | | 2 | | 3 | | 4 | | 5 | | 6 | | 7 | | 8 | | | | | | | | | | | | | | | | | | | | | | | | | | | | | | | | | | | | | | | | | | | | | | | | | | | | | | | | | | | | | | | | | | | | | | | | | | | | | | | | | | | | | | | | | | | | | | | |
|---|-----------|--|------------------|--------------|------------------|---------|-----------|---|-----------|--------------------|--|----------|--|-------|--|------------|--|--|--|--|--|--|--|--|--|--|--|--|--|--|--|--|--|--|--|----|--|------|--|-----------|--|--------------------|--|----|--|-------|--|--|--|--|--|----|--|-----|--|---------|--|--|--|-------|--|-------|--|--|--|--|--|----|--|--|--|---|--|------|--|--------|--|----|--|-----|--|-----|--|-----|--|----|--|----------|--|------|--|------|--|---|--|---|--|---|--|---|--|---|--|---|--|---|--|---|--|
| 序号/NO | 符号/Symbol | 名称/Name | 制造商/Manufacturer | 型号/Type | 规格/Specification | 单位/unit | 数量/Number | 物料编号/Material number | 备注/Remark | | | | | | | | | | | | | | | | | | | | | | | | | | | | | | | | | | | | | | | | | | | | | | | | | | | | | | | | | | | | | | | | | | | | | | | | | | | | | | | | | | | | | | | | | | | | | | | | | | | | |
| 1 | Q1 | 热磁断路器/Circuit-breaker | CHNT | NS2-25 | 6-10A | PCS | 1 | YE40022501100 | (1) | A | | | | | | | | | | | | | | | | | | | | | | | | | | | | | | | | | | | | | | | | | | | | | | | | | | | | | | | | | | | | | | | | | | | | | | | | | | | | | | | | | | | | | | | | | | | | | | | | | | | |
| 2 | | 欠压脱扣器/Undervoltage release | CHNT | NS2-UV220 | 220V | PCS | 1 | YE40222000900 | (1) | | | | | | | | | | | | | | | | | | | | | | | | | | | | | | | | | | | | | | | | | | | | | | | | | | | | | | | | | | | | | | | | | | | | | | | | | | | | | | | | | | | | | | | | | | | | | | | | | | | | |
| 3 | | 防水安装盒/Waterproof-box | CHNT | NS2-MC01 | ---- | PCS | 1 | YR40012000000 | (1) | | | | | | | | | | | | | | | | | | | | | | | | | | | | | | | | | | | | | | | | | | | | | | | | | | | | | | | | | | | | | | | | | | | | | | | | | | | | | | | | | | | | | | | | | | | | | | | | | | | | |
| 4 | Q2 | 热磁断路器/Circuit-breaker | CHNT | NS2-25 | 1.1-1.6A | PCS | 1 | YE10011600000 | (1) (2) | | | | | | | | | | | | | | | | | | | | | | | | | | | | | | | | | | | | | | | | | | | | | | | | | | | | | | | | | | | | | | | | | | | | | | | | | | | | | | | | | | | | | | | | | | | | | | | | | | | | |
| 5 | | 防水安装盒/Waterproof-box | CHNT | NS2-MC01 | ---- | PCS | 1 | YR40012000000 | (1) (2) | | | | | | | | | | | | | | | | | | | | | | | | | | | | | | | | | | | | | | | | | | | | | | | | | | | | | | | | | | | | | | | | | | | | | | | | | | | | | | | | | | | | | | | | | | | | | | | | | | | | |
| 6 | S1 | 安全开关/Safety switch | SCHMERSRC | TEND/TZ-9212 | AZ-15 | PCS | 1 | YE16921200000 | (1) | | | | | | | | | | | | | | | | | | | | | | | | | | | | | | | | | | | | | | | | | | | | | | | | | | | | | | | | | | | | | | | | | | | | | | | | | | | | | | | | | | | | | | | | | | | | | | | | | | | | |
| 7 | S2 | 切替开关/Safety switch | ---- | R210-C5LBW4P | 10A 250V | PCS | 1 | YE10210400000 | (1) (3) | | | | | | | | | | | | | | | | | | | | | | | | | | | | | | | | | | | | | | | | | | | | | | | | | | | | | | | | | | | | | | | | | | | | | | | | | | | | | | | | | | | | | | | | | | | | | | | | | | | | |
| 8 | K1 | VR拨码器/Time Dialer | YUYUN | CP-02A | AC220V | PCS | 1 | YE80222000600 | (1) (3) | B | | | | | | | | | | | | | | | | | | | | | | | | | | | | | | | | | | | | | | | | | | | | | | | | | | | | | | | | | | | | | | | | | | | | | | | | | | | | | | | | | | | | | | | | | | | | | | | | | | | |
| 9 | | 电线0.75*1C*200M红色 | | | | M | 3 | YE50750100000 | (1) | | | | | | | | | | | | | | | | | | | | | | | | | | | | | | | | | | | | | | | | | | | | | | | | | | | | | | | | | | | | | | | | | | | | | | | | | | | | | | | | | | | | | | | | | | | | | | | | | | | | |
| 10 | | 端子1.25-4Y(1000PCS/包) | | | | PAC | 0.016 | YE60100440200 | (1) | | | | | | | | | | | | | | | | | | | | | | | | | | | | | | | | | | | | | | | | | | | | | | | | | | | | | | | | | | | | | | | | | | | | | | | | | | | | | | | | | | | | | | | | | | | | | | | | | | | | |
| 11 | | 管形端子E1008 | | | | PCS | 8 | YE60100800200 | (1) | | | | | | | | | | | | | | | | | | | | | | | | | | | | | | | | | | | | | | | | | | | | | | | | | | | | | | | | | | | | | | | | | | | | | | | | | | | | | | | | | | | | | | | | | | | | | | | | | | | | |
| 12 | | 电缆锁头PG9 | | | | PCS | 1 | YE67000940000 | (1) | | | | | | | | | | | | | | | | | | | | | | | | | | | | | | | | | | | | | | | | | | | | | | | | | | | | | | | | | | | | | | | | | | | | | | | | | | | | | | | | | | | | | | | | | | | | | | | | | | | | |
| 13 | | 电缆线1.5*4C*1.1M | | | | BA | 1 | BE51150403250 | (1) | | | | | | | | | | | | | | | | | | | | | | | | | | | | | | | | | | | | | | | | | | | | | | | | | | | | | | | | | | | | | | | | | | | | | | | | | | | | | | | | | | | | | | | | | | | | | | | | | | | | |
| 14 | | 电缆线1.5*5C*4M | | | | BA | 1 | BE51154700050 | (1) | | | | | | | | | | | | | | | | | | | | | | | | | | | | | | | | | | | | | | | | | | | | | | | | | | | | | | | | | | | | | | | | | | | | | | | | | | | | | | | | | | | | | | | | | | | | | | | | | | | | |
| 15 | | 电线0.75*3C*4M(中性线(零线)使用蓝色) | | | | M | 4 | YE50050300100 | (1) | C | | | | | | | | | | | | | | | | | | | | | | | | | | | | | | | | | | | | | | | | | | | | | | | | | | | | | | | | | | | | | | | | | | | | | | | | | | | | | | | | | | | | | | | | | | | | | | | | | | | |
| 16 | | 电缆线1.5*4C*1.1M | | | | BA | 1 | BE51150403250 | (1) (2) | | | | | | | | | | | | | | | | | | | | | | | | | | | | | | | | | | | | | | | | | | | | | | | | | | | | | | | | | | | | | | | | | | | | | | | | | | | | | | | | | | | | | | | | | | | | | | | | | | | | |
| 17 | | 电线0.75*3C*4M(中性线(零线)使用蓝色) | | | | M | 4 | YE50050300100 | (1) (3) | | | | | | | | | | | | | | | | | | | | | | | | | | | | | | | | | | | | | | | | | | | | | | | | | | | | | | | | | | | | | | | | | | | | | | | | | | | | | | | | | | | | | | | | | | | | | | | | | | | | |
| 18 | Y | 电磁阀/Solenoid valve | AIRTAC | ---- | 4V210-08/AC220V | PCS | 1 | ---- | (3) | | | | | | | | | | | | | | | | | | | | | | | | | | | | | | | | | | | | | | | | | | | | | | | | | | | | | | | | | | | | | | | | | | | | | | | | | | | | | | | | | | | | | | | | | | | | | | | | | | | | |
| 19 | M1 | 粉碎电机/Granulating Motor | SHIYUAN | 3.7kW | 400V 50Hz | PCS | 1 | ---- | (1) | | | | | | | | | | | | | | | | | | | | | | | | | | | | | | | | | | | | | | | | | | | | | | | | | | | | | | | | | | | | | | | | | | | | | | | | | | | | | | | | | | | | | | | | | | | | | | | | | | | | |
| 20 | M2 | 吸料风机/Solution blower | REXCHIP | 0.55KW | 400V 50Hz | PCS | 1 | ----- | (1) (2) | | | | | | | | | | | | | | | | | | | | | | | | | | | | | | | | | | | | | | | | | | | | | | | | | | | | | | | | | | | | | | | | | | | | | | | | | | | | | | | | | | | | | | | | | | | | | | | | | | | | |
| <table border="1" style="width:100%; border-collapse: collapse;"> <tr> <td colspan="2">机型版本 Ver A</td> <td colspan="14">注: (1)表示非电控箱安装; (2)表示送料风机选配件; (3)选配VR立即回收装置.</td> </tr> <tr> <td colspan="2"></td> <td colspan="2"></td> <td colspan="2">制图</td> <td colspan="2">版号 0</td> <td colspan="2">标题 SG-M43</td> <td colspan="2">图号 SG-M43-400V-0-3</td> <td colspan="2">比例</td> <td colspan="2">第 3 张</td> </tr> <tr> <td colspan="2"></td> <td colspan="2"></td> <td colspan="2">设计</td> <td colspan="2">核 准</td> <td colspan="2">电气元件明细表</td> <td colspan="2"></td> <td colspan="2">标准 GB</td> <td colspan="2">共 3 张</td> </tr> <tr> <td colspan="2"></td> <td colspan="2"></td> <td colspan="2">校对</td> <td colspan="2"></td> <td colspan="2" rowspan="2" style="text-align: center;">  信易電熱機械股份有限公司 Shini Plastics Technologies, Inc. </td> <td colspan="2">机器电压</td> <td colspan="2">3φ400V</td> </tr> <tr> <td colspan="2">标记</td> <td colspan="2">更改前</td> <td colspan="2">更改后</td> <td colspan="2">更改人</td> <td colspan="2">日期</td> <td colspan="2">20230831</td> <td colspan="2">机器频率</td> <td colspan="2">50Hz</td> </tr> <tr> <td colspan="2">1</td> <td colspan="2">2</td> <td colspan="2">3</td> <td colspan="2">4</td> <td colspan="2">5</td> <td colspan="2">6</td> <td colspan="2">7</td> <td colspan="2">8</td> </tr> </table> | | | | | | | | | | | | | | | | 机型版本 Ver A | | 注: (1)表示非电控箱安装; (2)表示送料风机选配件; (3)选配VR立即回收装置. | | | | | | | | | | | | | | | | | | 制图 | | 版号 0 | | 标题 SG-M43 | | 图号 SG-M43-400V-0-3 | | 比例 | | 第 3 张 | | | | | | 设计 | | 核 准 | | 电气元件明细表 | | | | 标准 GB | | 共 3 张 | | | | | | 校对 | | | |  信易電熱機械股份有限公司 Shini Plastics Technologies, Inc. | | 机器电压 | | 3φ400V | | 标记 | | 更改前 | | 更改后 | | 更改人 | | 日期 | | 20230831 | | 机器频率 | | 50Hz | | 1 | | 2 | | 3 | | 4 | | 5 | | 6 | | 7 | | 8 | |
| 机型版本 Ver A | | 注: (1)表示非电控箱安装; (2)表示送料风机选配件; (3)选配VR立即回收装置. | | | | | | | | | | | | | | | | | | | | | | | | | | | | | | | | | | | | | | | | | | | | | | | | | | | | | | | | | | | | | | | | | | | | | | | | | | | | | | | | | | | | | | | | | | | | | | | | | | | | | | | | | | | |
| | | | | 制图 | | 版号 0 | | 标题 SG-M43 | | 图号 SG-M43-400V-0-3 | | 比例 | | 第 3 张 | | | | | | | | | | | | | | | | | | | | | | | | | | | | | | | | | | | | | | | | | | | | | | | | | | | | | | | | | | | | | | | | | | | | | | | | | | | | | | | | | | | | | | | | | | | | | | | |
| | | | | 设计 | | 核 准 | | 电气元件明细表 | | | | 标准 GB | | 共 3 张 | | | | | | | | | | | | | | | | | | | | | | | | | | | | | | | | | | | | | | | | | | | | | | | | | | | | | | | | | | | | | | | | | | | | | | | | | | | | | | | | | | | | | | | | | | | | | | | |
| | | | | 校对 | | | |  信易電熱機械股份有限公司 Shini Plastics Technologies, Inc. | | 机器电压 | | 3φ400V | | | | | | | | | | | | | | | | | | | | | | | | | | | | | | | | | | | | | | | | | | | | | | | | | | | | | | | | | | | | | | | | | | | | | | | | | | | | | | | | | | | | | | | | | | | | | | | | | |
| 标记 | | 更改前 | | 更改后 | | 更改人 | | | | 日期 | | 20230831 | | 机器频率 | | 50Hz | | | | | | | | | | | | | | | | | | | | | | | | | | | | | | | | | | | | | | | | | | | | | | | | | | | | | | | | | | | | | | | | | | | | | | | | | | | | | | | | | | | | | | | | | | | | | |
| 1 | | 2 | | 3 | | 4 | | 5 | | 6 | | 7 | | 8 | | | | | | | | | | | | | | | | | | | | | | | | | | | | | | | | | | | | | | | | | | | | | | | | | | | | | | | | | | | | | | | | | | | | | | | | | | | | | | | | | | | | | | | | | | | | | | | |
| D | | D | | | | | | | | | | | | | | | | | | | | | | | | | | | | | | | | | | | | | | | | | | | | | | | | | | | | | | | | | | | | | | | | | | | | | | | | | | | | | | | | | | | | | | | | | | | | | | | | | | | | | | | | | | | |