

HAD

Heatless Air Dryer

Date: Sep., 2020

Version: Ver.A (English)



Contents

1. General Description	5
1.1 Coding Principle.....	6
1.2 Features.....	6
1.3 Technical Specifications	8
1.3.1 Outline Drawing.....	8
1.4 Safety Regulations.....	10
1.4.1 Security Labels.....	10
1.4.2 Transportation and Storage.....	11
1.5 Exemption Clause.....	13
2. Structure Features and Working Principle.....	14
2.1 Working Principle Diagram	14
2.2 Circuit Diagram	15
2.2.1 Control Board of HAD (AF-01).....	15
3. Installation and Debugging	17
3.1 Important Notices for Installation.....	17
4. Application and Operation.....	19
4.1 Panel Instruction	19
4.2 Device Operation Procedures.....	20
5. Trouble-shooting.....	23
6. Repair and Maintenance	25
6.1 Daily Inspection.....	25
6.2 Parts Replacement	26
6.3 Maintenance Schedule	31
6.3.1 About the Machine	31
6.3.2 Electrical Installation.....	31
6.3.3 Daily Check	31
6.3.4 Weekly Check	31

Table Index

Table 1-1: Specifications	9
---------------------------------	---

Picture Index

Picture 1-1: Outline Drawing	8
Picture 2-1: Working Principle Diagram	14
Picture 2-2: Control Board of HAD (AF-01)	15
Picture 2-3: Sequence Chart of the Solenoid Valve	16
Picture 4-1: Operation Panel	19
Picture 6-1: Absorbent Replacement Diagram	27
Picture 6-2: Adsorption Barrel	28
Picture 6-3: Dew Point Indicator	29
Picture 6-4: Muffler	29
Picture 6-5: Orifice	30
Picture 6-6: Valve Sheet, O-ring and Check Valve	30

1. General Description



Please read this manual carefully before installation and operation to prevent accidents and damages of the machine.



Forbidden to process toxic or flammable materials!

When collocating with SHD-U (combined as SHD-U-HD model), it is suitable for drying engineering plastics with a certain requirement for moisture content such as ABS, PC, PE and PVC. When collocating with SCAD in use with low dew-point dried air, it can dry material more easily.



Model: HAD0106-06

1.1 Coding Principle

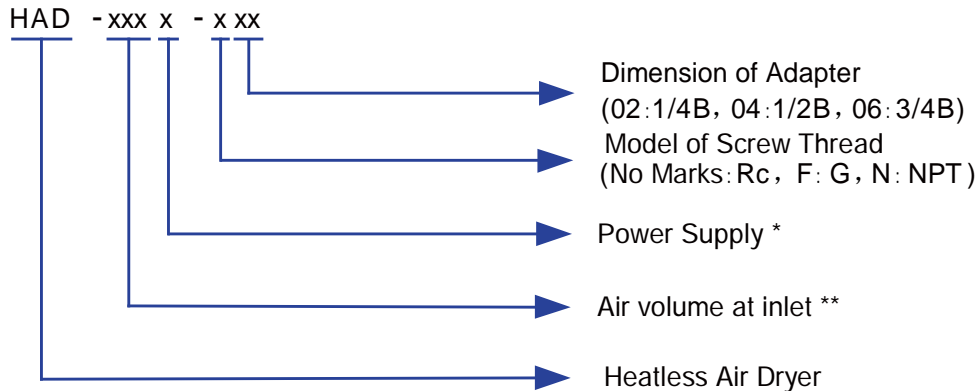

Note: *

*0: 1 AC100V(50Hz) AC100~110V(60Hz) 1: 1 AC110V(50Hz)

5: 1 AC200V(50Hz) AC200~220V(60Hz) 1: 1 AC220V(50Hz)

**0106: 0.106m³/min 0206: 0.206 m³/min 0.356: 0.356 m³/min

1.2 Features

- With compact structure and stable operation, the range of dew-point variation is $\pm 3^{\circ}\text{C}$ and the noise level is lower than 85dB.
- Auto circuit control and safety devices are simple and stable. After operation for 5,000~10,000 hours, the indicator light calls for renewal of corresponding parts to ensure safe handling with optimal performance.
- High-quality absorbent of 4A molecular sieve.
- Aluminum alloy die-casting is adopted which offers good shape, convenience for disassembling and maintenance.
- The throughput is 0.1~0.35m³/min, working pressure is 0.39~0.98MPa and the dew-point can reach -40°C ~-60 $^{\circ}\text{C}$.
- The rational tank design makes the contact time of compressed air and absorbent adjustable which reaches the required dew-point of finished compressed air.
- The amount of regenerative air is adjustable according to operating load of the dryer to make optimal the velocity and time of the flowing air passing through the absorbent coat and bring the performance of the absorbent into full play.
- Rational system configuration makes it possible to remove oil and heavy pollutant in the air before it enters the drying tank.

- High-quality SMC solenoid valve and microprocessor have the function of automatic timing and task switching between the two tanks.

All service work should be carried out by professional maintenance personnel. This manual contains instructions for both operation and Maintenance. Chapter 6, which contains service instructions, is intended for maintenance staff. Other chapters contain instructions are for the operator.

Any modifications of the machine must be approved by SHINI in order to avoid personal injury or damages to machine. Warranties are inapplicable once unauthorized retrofit is done to the machine.

Our company provides excellent after-sales service. Should you have any problem during using the machine, please contact Shini Company or your dealer.

Headquarter and Taipei factory:

Tel: (886) 2 2680 9119

Shini Plastics Technologies (Dongguan), Inc:

Tel: (86) 769 8111 6600

Shini Plastics Technologies India Pvt.Ltd.:

Tel: (91) 250 3021 166

1.3 Technical Specifications

1.3.1 Outline Drawing

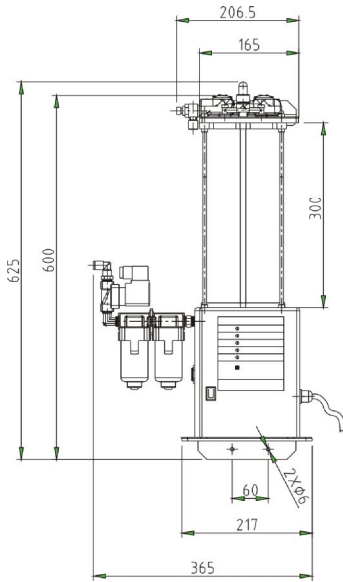

HAD-0106-06

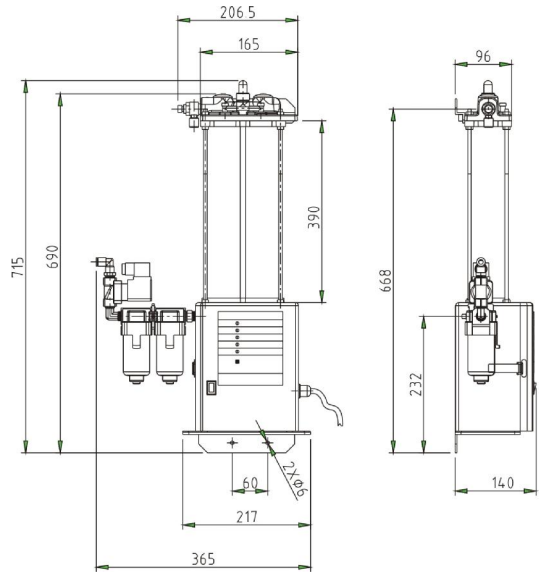

HAD-0206-06

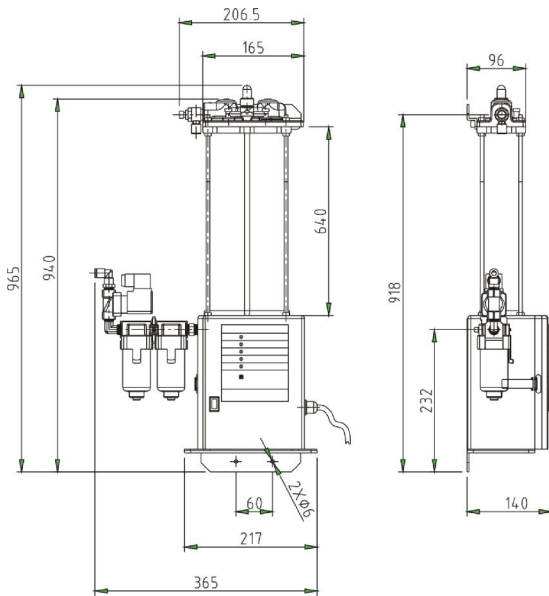

HAD-0356-06

Picture 1-1: Outline Drawing

Table 1-1: Specifications

Model		HAD-0106 -06	HAD-0206 -06	HAD-03506 -06
Processing capacity	Air volume at inlet (m ³ /min)	0.10	0.20	0.35
	Air volume at outlet (m ³ /min)	0.086	0.172	0.30
	Regenerated air flow (m ³ /min)	0.014	0.028	0.05
Range of application	Applicable medium	Compressed air		
	Allowable pressure (MPa)	0.39~0.98		
	Inlet air temperature (°C/%)	5~50 / Not saturated (no droplet exists)		
	Ambient temperature (°C)	2~40		
	Dew point of outlet air (°C)	4~6kg (-40~-60 at atmospheric pressure)		
Electric rating	1Φ 230V 50Hz			
Dimensions	External dimensions (mm)	625×217	715×217	965×217
	Pipe diameter	Rc 3/8		
	Mass (kg)	7.7	9.2	12.2
Equipment specifications	Desiccant. Regeneration method	Pressure Swing Method		
	Desiccant. Regeneration cycle time	2 min. (4, 6, 8 min. Switching)		
	Inlet filter / Element (Filtration)	0.01μm		
	Outlet filter / Element (Filtration)	1μm		

Notes: The air tightness test should conform to testing standard of JIS Z 2332.

1.4 Safety Regulations

1.4.1 Security Labels

Operation should be in accordance with safety guidelines in the manual to avoid bodily injury and damage to the machine.

The user must conform to the following safety rules when operating the machine.



Installation of the device is allowed only to the professional electrician.

Before maintaining and repairing the device, be sure to turn off the main switch and control switch.



Warning! High Voltage!

This label is posted on enclosure of the electrical control cabinet!



Attention!

Don't try to use any unauthorized fluid, and the fluid applicable is compressed air only. If any fluid other than compressed air is used, the device can be damaged resulting in bodily injury or gas leakage.

Don't try to use a pressure beyond the maximum pressure allowed, the maximum pressure is 0.98MPa. If the working pressure exceeds the maximum pressure, this device may be damaged or resulted in gas leakage etc.

Don't place anything on the device, otherwise the device can turn over or fall down resulting in personal injury.

Don't use flammable sprays in vicinity of the device. Area adjacent to the device must be free from flammable materials. Otherwise they can be ignited, for instance, by switch sparks resulting in fire hazards.

Don't use the device for medical purposes, especially for purposes directly influencing the human organs such as respiratory organs.



Attention!

Regular inspections are not essential because all the electrical components in the electrical control cabinet have been tightly installed.

Before cleaning, maintaining or inspecting the device, be sure to turn the source power off.

It may cause burns.

When transferring the device to a third person, be sure to attach this manual with it to ensure the safety of the new operator.

1.4.2 Transportation and Storage

- 1) After unpacking the device, check the product contained against the specification plate to make sure that it is what you have ordered.
- 2) Check if the product suffered damage or deformation during transportation. May any failure is found, please contact your dealer.

Precautions when transferring in the device

- 1) Be careful.
- 2) Don't hold the tension bolts fastening the adsorption barrel when moving the device.
- 3) Do not rotate the machine and avoid collision with other objects during transportation to prevent improper functioning.
- 4) Although the structure of the machine is well-balanced, it should also be handled with care when lifting the machine for fear of falling down.

Important Notes

It is prohibited to place the device upside down in case failure should occur.

Storage (When the device is not going to be used for a long time)

- 1) Turn power off
- 2) Turn off the source power.
- 3) Discharge drain water
- 4) Discharge the drain water in the attached air filter via the auto drain trap.

- 5) Storing the device
- 6) Make sure that the device is protected from foreign substances such as dusts, dirt, rain, water and snow. Close the inlet and outlet valves.
- 7) Resuming the device operation
- 8) Check each component on the air dryer for any trouble, and then start the device according to the procedures provided in “Application and Operation”.
- 9) Two insert adsorption barrel assemblies, element assembly set (one LSF and MSF) , one check valve assembly set, one muffler and replacement pericualr sheet are attached to 10,000 hours assembly set.
- 10) The spare parts set assembly for 5,000 or 10,000 hours encloses a check label. When the spare parts have been replaced, please write the next time for replacement on the label and then stick it on the device, and it is also a standard of maintenance time.

Don't use the device under the following conditions:

- 1) Cable is damaged.
- 2) When the device is placed on wet floor or exposed to rain.
- 3) When the machine is disassembled or damaged and no inspection and installation is executed.
- 4) Surrounding space of the device is less than 1m or flammable objects are located within 2m of the device.
- 5) Vibration and magnetic effect exist in the working area.

Scraping

When the equipment has run out and can not be used any more, unplug the power supply and dispose it properly according to local code.

Fire Alarm



In case of fire, CO₂ dry powder fire extinguisher should be applied.

1.5 Exemption Clause

The following statements clarify the responsibilities and regulations born by any buyer or user who purchases products and accessories from Shini (including employees and agents).

Shini is exempted from liability for any costs, fees, claims and losses caused by reasons below:

1. Any careless or man-made installations, operation and maintenances upon machines without referring to the Manual prior to machine using.
2. Any incidents beyond human reasonable controls, which include man-made vicious or deliberate damages or abnormal power, and machine faults caused by irresistible natural disasters including fire, flood, storm and earthquake.
3. Any operational actions that are not authorized by Shini upon machine, including adding or replacing accessories, dismantling, delivering or repairing.
4. Employing consumables or oil media that are not appointed by Shini.

2. Structure Features and Working Principle

2.1 Working Principle Diagram

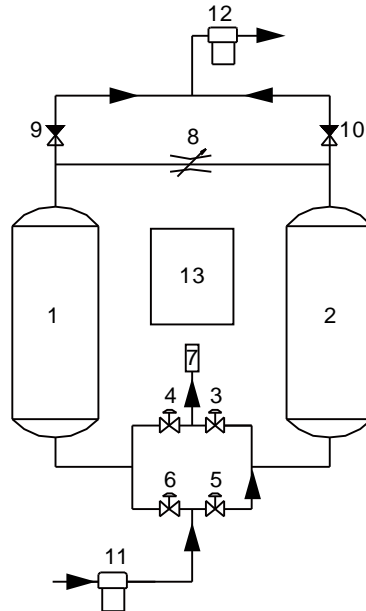

Picture 2-1: Working Principle Diagram

Heatless regenerative air dryer takes advantage of theory of Pressure Swing Adsorption. Desiccant adsorbs moisture under pressure and releases moisture under reduced pressure. The compressed air after passing through inlet filter 11 enters into dry barrel 1 (or dried barrels 2) through pneumatic control valve 6 (or 5). Then it make absorption dry with desiccant bed layer, and later exist from non-return valve 9 (or 10) to enter outlet filter 12 to be filtered, finally exist from the outlet to dry and purify air. A part of dry air (about 15%) enters dry barrel 2 (or dried barrel 1) through current limitation pipe 8 to blow and regenerate desiccants with saturated water, then air passes through pneumatic control valves 3 (or 4) to exist out of muffler 7. Drying barrel 1, 2 work alternately to regenerate.

2.2 Circuit Diagram

2.2.1 Control Board of HAD (AF-01)

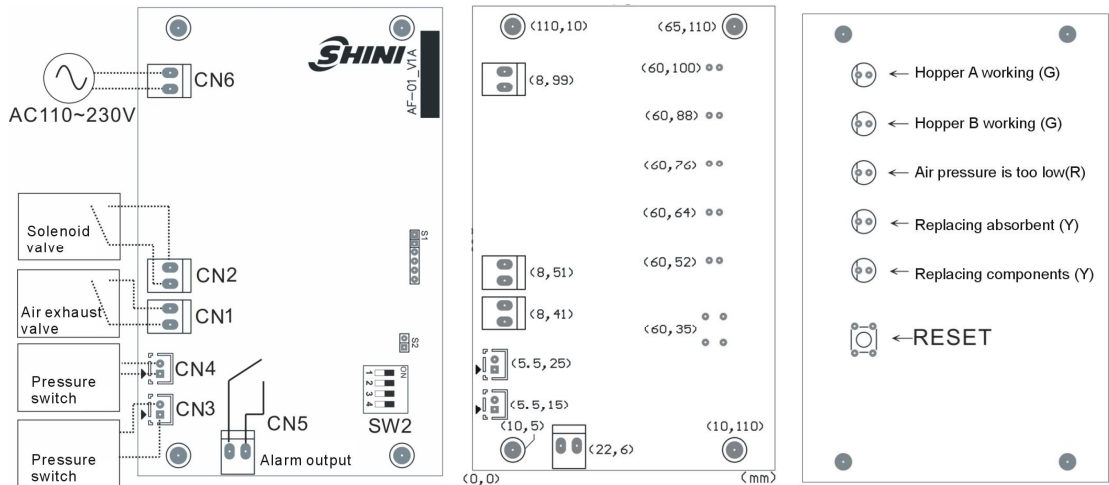

Picture 2-2: Control Board of HAD (AF-01)

Instructions for CN1~CN6 are shown in the above picture.

SW2 indicates working time setting.

Short these two terminals on S2 to cancel the pressure monitor.

- 1) SW2 setting (time of sequence chart “a” of control solenoid valve, terminal 3 and 4 are reserved).

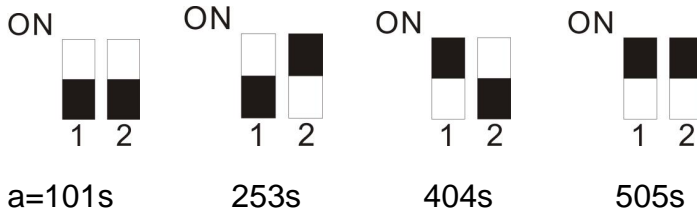

- 2) The green lamp is highlighted when adsorption barrel A and B are in operation.
- 3) After the running time reaches to 5,000hrs, the alternate indicator of input and output will be light; the lamp indicates absorbent replacement will be highlighted as the time reaches 10,000 hours.
- 4) Press the reset switch for three seconds, the yellow lamp glitters which indicates the cumulative running time is cleared to 0.

- 5) When the external pressure switch undergoes low pressure, the red lamp is highlighted and the alarm signal is sent out. However, the solenoid valve keeps working.

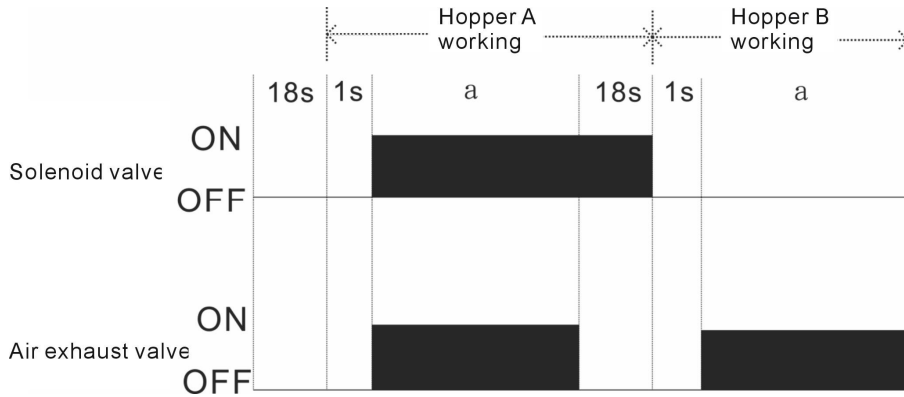

Picture 2-3: Sequence Chart of the Solenoid Valve

3. Installation and Debugging

Please install HAD at the place where makes it easy to maintain.

3.1 Important Notices for Installation

- 1) Maker's warranty is not applicable to any trouble resulting from unauthorized retrofit.
- 2) This device must not be installed in a place where leakage of flammable gases can occur. Otherwise, the device can be ignited.
- 3) The device must not be installed in a place covered by water to prevent electric shock or fire hazard (excepting models manufactured to the water proof specifications).
- 4) Don't use the device for medical purposes.
- 5) Don't use the device for purpose directly influencing the human body such as respiratory organs.
- 6) Installation must be implemented in compliance with the procedures and requirements stated in this construction manual. Improper installation can result in electric shock or fire hazard.
- 7) Contact your dealer or specialized sub-contactor for the device installation. Don't try to install the device by yourself, because electric shock or fire hazard may occur.
- 8) Electric work must be done in accordance with instruction manual. A special circuit must be provided for the device. If capacity of the circuit is not sufficient or its installation is inappropriate, electric shock or fire hazard may result.
- 9) Specified cable must be used for the wiring. Cable used must be positively fixed so that the terminal connection may not be exposed to external force from the cable. Improper or insufficient connection or fixing can result in electric shock, undesirable heat build-up or fire hazard.
- 10) Grounding must be provided

Grounding cable must not be connected to the gas pipe, water pipe or lighting rod. If the device is improperly grounded, electric shock may result.



Attention

If the device is inappropriately used, serious personal injury of the user or property damage can result.

- 1) It is prohibited to step on or place things on the device. Such practices can result in personal injury due to the overturned, broken or fallen device.
- 2) The device must be installed in a place that can sufficiently support the weight. It also must be placed horizontally and means for preventing its overturn must be provided. Inappropriate installation can result in gas leakage and personal injury due to the overturned device or device damage.
- 3) An earth leakage breaker must be provided. If it is not provided, electric shock can result. Appropriate drain piping must be done. If appropriate piping is not provided, property damage can result from leaked water.

4. Application and Operation

4.1 Panel Instruction



Picture 4-1: Operation Panel

Item	Indicator	Content	Alarm Content	Reset Alarm
Operation indicator of adsorption barrel A (start/stop)	On	The device is in operation		
	Off	The device is in regeneration process or stops		
Operation indicator of adsorption barrel B (start/stop)	On	The device is in operation		
	Off	The device is in regeneration process or stops		
Lower air pressure indicator (alarm)*	On	Low pressure	Regulate the pressure	
	Off	Normal pressure		
Absorbent replacement indicator (alarm)*	On	Operating time reaches 10,000 hours	Replace absorbent and check valve	Refer to reset switch
	Off	Calculating operation time		
Components replacement indicator (alarm)*	On	Operating time reaches 5,000 hours	Replace inlet, outlet filter and muffler	Refer to reset switch
	Off	Calculating operation time		
	Off	Adsorption barrel switches normally		
	Off	running time in memory is normal		
Reset switch	Keep pressing down the reset switch for 3s until the indicator light again to clear the accumulated running time of absorbent or components.			

Notice: * means that only activate alarm while not stop the unit.

Optional pressure sensor is installed to monitor switching status of the adsorption barrel. For details please contact your dealer.

4.2 Device Operation Procedures

For turning on the device for the first time or after a long time of storage

Warning

- 1) Don't try to operate the device with wet hands, nor try to touch electric parts with wet hands. Otherwise, electric shock can result.
- 2) Don't try to operate the device when the cabinet is open.
- 3) Don't expose the device or machine room, nor wash them with water. Otherwise, electric or fire hazard can result.
- 4) If a failure is detected on the device, stop the device, turn off the source power and contact your dealer or specialized sub-contractor.

Important Notices

- 1) The device after its initial installation or replacement of absorbent may contains moisture. If so, turn on regenerative operation of the device for 4 to 5 hours according to the following procedures. (Regeneration time varies with conditions)
- 2) Feed the compressed air gradually. If it is fed abruptly at a higher flow rate, drain water may be whirled up and internal parts may be damaged.
 1. Close the inlet, outlet and bypass valve.
 2. Open the inlet valve gradually so that compressed air may be fed to the device. During this process, you may hear air leakage sound. It is caused by regenerated air flowing out and you don't have to worry about it.
 3. Turn on the power as the device is pressurized. (Make sure that the operation lamp is turned on. If the lamp is turned off, press the operation switch.)
 4. Make sure that the adsorption barrel A and B are alternately turned on in certain intervals repeating absorption and regeneration. Considering the initial regeneration, this unit can work normally in running 10minutes.
 5. When the regenerative operation is complete, open the outlet valve gradually to bleed compressed air.

Stopping / Alarm Signals / Output

Stopping

Important Notices:

- 1) Don't operate the switches frequently to avoid failure of the device.
- 2) Close the outlet valve while operation of the device is being interrupted.
- 3) If the inlet and outlet valves are left open, the absorbent can absorb moisture in the pipe and a sufficiently low dew point can't be obtained when the device starts again.
 1. Close the outlet valve.
 2. Implement regenerative operation for approximately 10 minutes. (This operation will not only ensure smooth starting of the device when you re-start it but also is effective in expanding the service life of the absorbent.)
 3. Turn off the device power.
 4. Make sure that the operation lamp is turned off.
 5. Close the inlet valve.
 6. Stop the air compressor.

Alarm Signals / Output

Alarm signals and output

- 1) Absorbent replacement alarm (signals / output)
 1. The device will sound alarm of absorbent (adsorption barrel) and check valve (check valve assembly) replacement when total running time reaches 10,000 hours.
 2. Continues operating.
 3. Reset the alarm.
- 2) Components replacement alarm (signals / output)
 1. The device will sound alarm of components and muffler replacement when total running time reaches 5,000 hours.
 2. Continues operating.
 3. Reset the alarm.

- 3) Both adsorption barrel A and B switch abnormally (option) (signals / output)
 1. Both adsorption barrel A and B switch abnormally per 2min, the alarm will be activated.
 2. After return to normal operation, it will be automatically reset.
- 4) Memory error (signals / output)
 1. When accumulated time in memory calculates abnormally, the alarm will be active. The running time can not be calculated if the controller works abnormally. Continuously for a long time, components and absorbent replacement alarm can not be active after running designed time (5,000 or 10,000hrs)
 2. Continues operating.
 3. Turn off the power and turn it on again to delete the error. For any problem please contact your dealer.

Resetting an Alarm

As the element replacement lamp comes on, replace the element, then press the reset switch for at least 3 seconds. The lamp will be turned off and cumulative running time will also be cleared to 0.

Important Notices

When the same alarm recurs, there must be some problems in the device operating conditions. Contact your dealer as soon as possible.

The device keeps operating as alarm signal is sent out.

5. Trouble-shooting

Warning

Before taking any remedial action, be sure to bleed compressed air in the device. Otherwise, residual compressed air may burst out and results in bodily injury.

If a trouble is detected, stop the operation and turn off the source power, then contact your dealer or specialized sub-contractor. If the operation is continued without eliminating the trouble, electric shock and fire hazard can occur.

Before taking any remedial action, stop the air compressor and turn off the power. Otherwise, electric shock may occur.

Quick Reference for Failures and Errors

The device doesn't operate when switching on:

State	Possible causes	Solutions
The operation lamp is not on.	Failure of the switch; Failure of the controller; Supply voltage is inappropriate; Power is not connected.	Replacement; Replacement; Adjust voltage to the specified level; Feed the specified power. (It must be within $\pm 10\%$ of the rating)

The device operates with the following troubles:

State	Possible causes		Solutions
Dew point indicator is lighted in pink.	Water or oil droplets are presented in the device	At inlet side	Protect the device from water or oil droplets: Check and, if necessary, repair the drain trap on the inlet side. Check and, if necessary, replace the filter element.
		At inlet side	Install a freezing type dryer. Add a drain filter.
	Operating pressure is lower than the specified level.	Increase the operating pressure above the allowable minimum level.	
	Air volume to be processed is excessive.	Reduce the air volume below the rating.	
	Inlet humidity is too high.	Reduce the inlet humidity below the rating.	
	Absorbent is deteriorated.	Replace the absorbent.	
Switching between operations is not available.	Muffler is clogged.	Replace the muffler.	
	Failure of the controller.	Contact your dealer.	
	Orifice is clogged.	Dismount the orifice and air-blow it.	
	Inlet valve is inoperable	Contact your dealer.	
	Failure of the exhaust valve.		
	Muffler is clogged	Replace the muffler.	
Failure of the check valve.	Contact your dealer.		

6. Repair and Maintenance

6.1 Daily Inspection

Warning

- 1) Before cleaning, maintaining or inspecting the device, be sure to bleed compressed air in the device. Otherwise, residual compressed air can burst out resulting in personal injury.
- 2) When you have dismantled the cabinet for inspection or cleaning, be sure to mount it after the work. If operation is turned on when the cabinet is open or dismantled, personal injury or electric shock can result from accidentally touching internal part of the device.
- 3) Make sure that the device or machine room is not exposed to water and it mustn't be cleaned with water. Otherwise, personal injury or electric shock can result.
- 4) Before cleaning, maintaining or inspecting the device, make sure that the source power is turned off. Otherwise, electric shock or personal injury can result.
- 5) Please clean up foreign substances on the blades of the blower regularly to prevent damages to the blower.

Daily Inspection

- 1) Check the operating pressure
If the device operating pressure is lower than that of the orifice used, the intended performance can be adversely affected because sufficient volume of regenerated air is unavailable. The device operating pressure must be always higher than that of the orifice used.
- 2) Check color of the dew point indicator
As long as it is lighted in blue, you can be sure that normal operation is maintained. If dew point at the outlet goes higher, the indicator will come on in pink or white. In that case, please replace it.

Inlet Air Dew Point	Color of Indicator
-30°C and below -30°C	Dark blue
-18°C	Light blue
-10°C	Light pink
-5°C	Pink

Notice: The color of the indicator is tested under pressure of 0.7MPa and at 30°C

- 3) Make sure that switching of operations between adsorption barrel A and B is normally performed

The intended performance may not be maintained if switching between “Suction” and “Regeneration” is not done smoothly. You can be sure that switching of operations is normally performed when exhausting sound is audible once every two minutes or so.

- 4) Check the filter drain trap

If water or oil droplets enter the device due to inadequate drainage, service life of an absorbent can be significantly affected. Check and make sure that the drain traps for the after cooler, refrigerating air dryer, air tank and filter being located between the air compressor and the device work normally.

6.2 Parts Replacement

Warning

Before starting inspection, be sure to bleed compressed air and turn off the source power. For the replacement parts, contact your dealer.

Identify parts replacement timing

Name of Part	Replacement Timing
Adsorption barrel	The absorbent replacement lamp comes on after operating 10,000 hours. Additional, if the dewpoint indicator shows gray or achromaticity, please change it simultaneously.
Element	Every 5,000 hours or 1 year; As the element replacement lamp comes on.
Muffler	Every 5,000 hours or 1 year; when elements (LSF·MSF) are replaced
Dew point indicator	When the adsorption barrel s are replaced.

Check valve (Check valve assembly)	Every 10,000 hours or 2 years; when the adsorption barrel are replaced.
------------------------------------	---

Notices: 1) Changing period is a protecting method based on certain operating condition, which is to change some parts on purpose before the faults appear.

- 2) Changing period is not same with the guarantee period. In addition, it is also possible to change them according to the operating condition. If some parts is confirmed to be changed according to fault and solution, please change them.
- 3) Please consult dealer according to "Identify parts replacement timing" when changing parts.
- 4) Please refer to "reset switch" in 4.1 to reset the accumulated time after changing parts in order to eliminate the alarm.

Replacing the adsorption barrel (absorbent)

If the original absorbent capability is lost due to life (normally it can be used for 10,000 hours) or degradation, replace it with our genuine absorbent. When our absorbent is not used, the intended device performance may not be warranted. When replacing the absorbent, the dew point indicator and O-ring must be replaced at the same time. See also in "Consumables Parts".

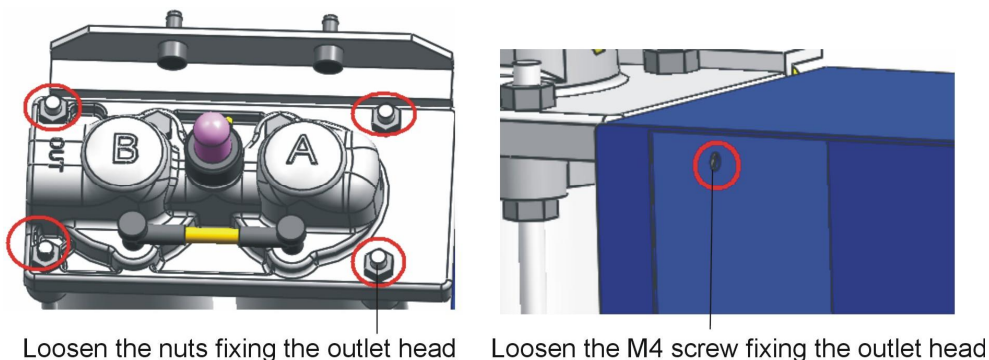

Picture 6-1: Absorbent Replacement Diagram

Instructions:

- 1) Remove the union in the air outlet side.
- 2) Loosen the nuts fixing the outlet head (at 4 positions) and M4 screws fixing the outlet head and the control board rear panel (at 1 position).
- 3) Replace the adsorption barrel with a new one.
 - ※ Also, replace the current O-ring with the attached new one after applying Vaseline on the surface.
- 4) Fasten the outlet side head and the rear panel of the control board in the reversed procedures to their removal procedures.

Important Notices

- 1) Because adsorption barrel are heavy, always wear safety shoes in case of bodily injury.
- 2) When replaing adsorption barrel A and B, please wear protections for fear that the absorbent podwer contact eyes and skin.
- 3) Pay attention to the vertical positioning of the adsorption barrel.
- 4) Don't scratch both ends and head of adsorption barrel A and B when installing them.
- 5) The currently used O-ring must be replaced with a new one. Before assembling the O-ring, be sure it is positively held in the place.
- 6) Care must be taken when tightening the nuts to avoid over-tightening.
- 7) Feed the compressed air gradually. If it is fed abruptly at a higher flow rate, drain water may be whirled up and internal parts may be damaged.

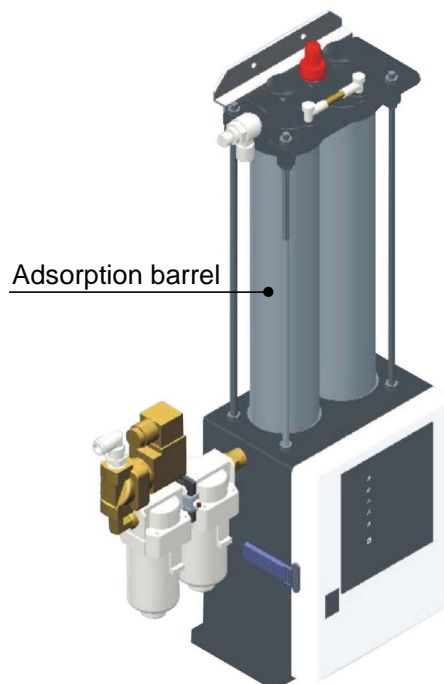

Picture 6-2: Adsorption Barrel

Replacing the dew point indicator

- 1) Loosen the screw situated at the top and replace the test paper in the indicator.

- 2) Don't fasten the screw too tightly in case of spoiling the monitor.
(Suggested torque is 0.59~0.78N·m.)

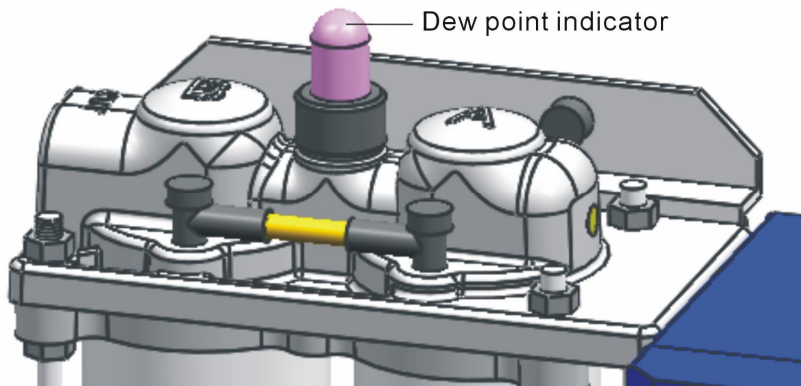

Picture 6-3: Dew Point Indicator

Replacing the muffler

The muffler works to suppress noise occurring when the regenerated air is being discharged. When it is blocked by absorbent powder, it hinders discharge of regenerated air and the absorbent will not be dried sufficiently. Therefore, it must be replaced every 5,000 hours. See also the “Consumable Parts”.

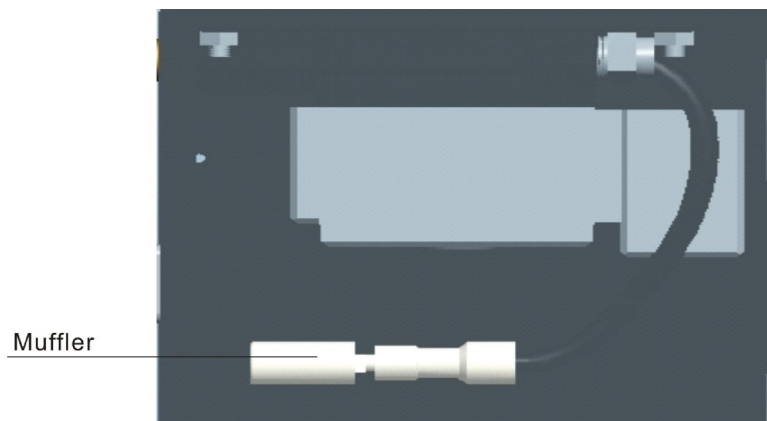

Picture 6-4: Muffler

- 1) Open the control board.
- 2) Remove the muffler, and replace it with a new one. (Insert the muffler to the root for fixation)
- 3) Close the control board.

Replacing the regeneration pipe

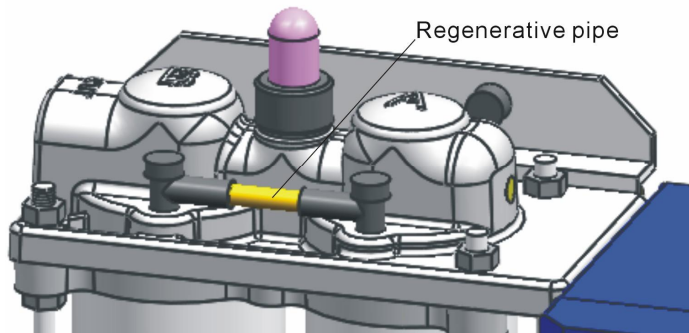

Picture 6-5: Orifice

Replacing the elements

Replacing the check valve (check valve assembly)

Replace the check valve every 10,000 hours or every 2 years. Refer to the “Consumable Parts”.

- 1) Remove the nuts (at 4 positions) fixing the outlet head and the M4 screws (at 1 position) fixing the outlet head and the rear panel of control board, and then remove the outlet head.
 - 2) Remove the valve sheet inside of the outlet head.
 - 3) Replace the check valve and O-ring.
- ※ When replacing, insert the concave portion of check valve into the guide stick.
- 4) Fasten the outlet head and the rear panel of the control board in the reversed procedures of the disassembly.

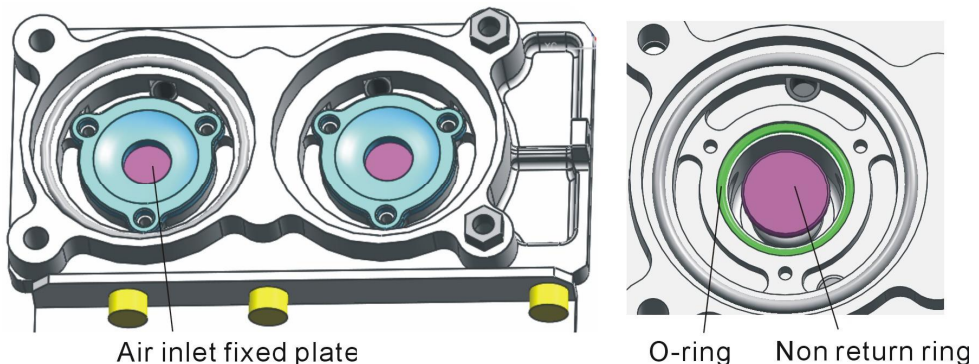

Picture 6-6: Valve Sheet, O-ring and Check Valve

6.3 Maintenance Schedule

6.3.1 About the Machine

Mode _____ SN _____ Manufacture date _____

Voltage _____ Φ _____ V Frequency _____ Hz

6.3.2 Electrical Installation

Voltage: _____ V _____ Hz

Fuse melting current: 1 Phase _____ A 3 Phase _____ A

Check phase sequence of power supply.

6.3.3 Daily Check

Check main power wiring.

Check POWER ON function.

6.3.4 Weekly Check

Check all wires of the machine.

Check if the joint point is loose.