

SCR Series
PET Crystallizer

Date: Jul, 2017

Version: Ver.E (English)



Contents

1. General Description	5
1.1 Coding Principle	6
1.2 Features	6
1.3 Technical Specifications.....	8
1.3.1 Specifications	8
1.3.2 Outline Drawing	9
1.4 Safety Regulations	10
1.4.1 Safety Signs and Labels.....	10
1.4.2 Transportation and Storage of the Machine.....	10
1.5 Exemption Clause	12
2. Structure Characteristics and Working Principle	13
2.1 Working Principle	13
3. Installation and Debugging.....	14
3.1 Installation of SCR	14
4. Application and Operation.....	16
4.1 Description of Control Panel	16
4.2 Start / Stop of the Machine.....	16
4.3 Operation of the Machine	16
4.4 Main Operation Processes.....	17
5. Trouble-shooting	18
6. Maintenance and Repair	20
6.1 Filter	22
6.2 Blower	22
6.3 Maintenance Schedule.....	23
6.3.1 About the Machine.....	23
6.3.2 Check After Installation.....	23
6.3.3 Daily Checking.....	23
6.3.4 Weekly Checking.....	23
6.3.5 Monthly Checking	23
6.3.6 Half-yearly Checking	23

Table Index

Table 1-1: Specifications.....	8
--------------------------------	---

Picture Index

Picture 1-1: Outline Drawing	9
Picture 2-1: Working Principle.....	13
Picture 3-1: Installation of SCR	14
Picture 3-2: Machine Ins Tallation Distance	15

1. General Description



Please make a careful study of this operation manual in order to prevent personal injuries and damage of the machine.

SCR closed-loop crystallizers used for constant crystallization of un-crystallized PET regrinds or pellets. Processed materials can then be dried and dehumidified directly. This system mainly consists of heating elements, insulated hopper and agitator screw mixing device. After un-crystallized PET materials fed into the hopper, the system starts crystallization and agitator starts blending to prevent formation in lumps. Crystallized materials can be conveyed to material storage bin or into drying hopper.



Mode: SCR-450U

1.1 Coding Principle

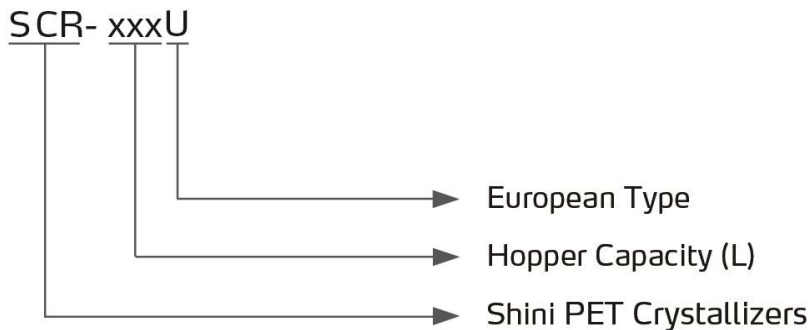

Notes:*

CE=CE Conformity ML=Optional with safety ladder

1.2 Features

1) Standard configuration

- Fixed speed of agitator makes materials not lump together during the crystallization.
- Simplify and improve drying efficiency.
- Materials can be dried under high temperature to improve drying efficiency.
- Cyclone dust collector is standard, which is applied to dust-rich place. Can effectively reduce the load on filter bag, and reduce the number of times of filter bag cleaning, thus extend the life span of the filter bag.
- With double overheat protectors, it can reduce the possibility of either mechanical or man-made problems.
- Equipped with rotary valve with good sealing performance, which can output crystallized material accurately.
- Equipped with material level switch, which can detect material level accurately and make operation reliable.
- Equipped with negative pressure tester(excluding SCR-1600U) to immediately test the ventilation of the filter. Give an alarm when the negative pressure is higher than the setting value, clean the filter to avoid blockage.

2) Accessory option

- Collocate with dehumidifier to fulfill dehumidification directly.
- Safety ladder is optional(only for SCR-900U and above models).
- Auto loader, hopper receiver, magnetic base, suction box are optional for material conveying.
- Optional feed screw for stable and even conveying of uncrystallized material.
- External pipeline is optional with the stainless steel configuration.

All service work should be carried out by a person with technical training or corresponding professional experience. The manual contains instructions for both handling and servicing. Chapter 6, which contains service instructions intended for service engineers. Other chapters contain instructions for the daily operator.

Any modifications of the machine must be approved by SHINI in order to avoid personal injury and damage to machine. We shall not be liable for any damage caused by unauthorized change of the machine.

Our company provides excellent after-sales service. Should you have any problem during using the machine, please contact the company or the local vendor.

Headquarter and Taipei factory:

Tel: (886) 2 2680 9119

Shini Plastics Technologies (Dongguan), Inc:

Tel: (86) 769 8111 6600

Shini Plastics Technologies India Pvt.Ltd.:

Tel: (91) 250 3021 166

1.3 Technical Specifications

1.3.1 Specifications

Table 1-1: Specifications

Model	SCR-160U	SCR-450U	SCR-900U	SCR-1600U	SCR-2500U
Ver.	B	D	E	D	A
Heater Power (kW)	12	24	48	96	128
Blower Power (kW)	0.55	2.2	3	7.5	15
Blending Motor Power (kW)	0.25	0.55	1.5	2.2	4
Max. Throughput (kg / hr)	50	150	300	500	750
Hopper Capacity (kg)	160	450	900	1600	2500
H(mm)	2380	3850	4550	5350	5710
H1(mm)	280	720	1040	820	890
H2(mm)	380	1060	1185	1240	1270
H3(mm)	---	---	5260	6010	6260
W(mm)	1040	2370	2890	2510	3700
W1(mm)	1140	1440	1930	2160	2310
W2(mm)	-	800	800	---	800
W3(mm)	---	---	3640	3295	4400
W4(mm)	---	---	2020	2200	2360
ΦA(inch)	3	5	6	8	8
ΦB(inch)	4	4	5	5	5
Weight (kg)	235	500	865	2290	2790

Notes: 1) Above maximum processing capacity is based on uncrystallized PET material of 0.85kg/L in density and 3~5mm in diameter.
 2) Power: 3Φ, 230 / 400 / 460 / 575VAC, 50 / 60Hz.

1.3.2 Outline Drawing

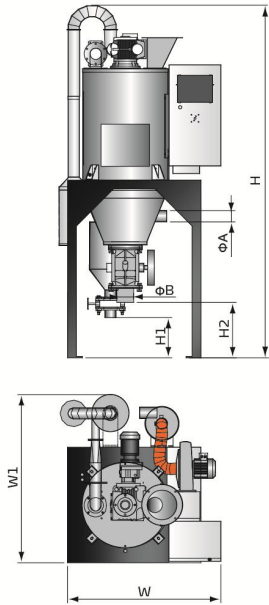

SCR-160U

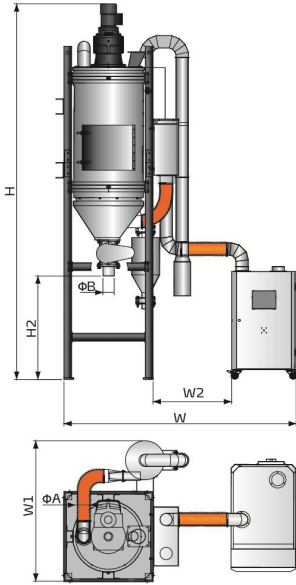

SCR-450U

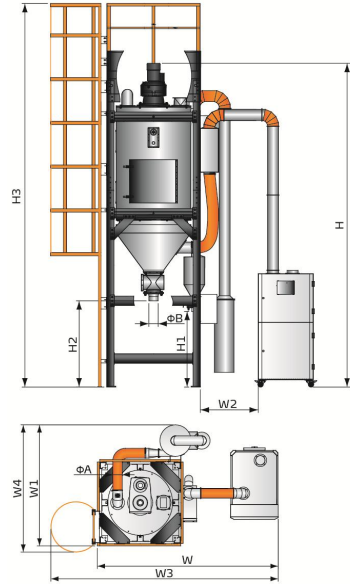

SCR-900U(Maintenance ladder is optional)

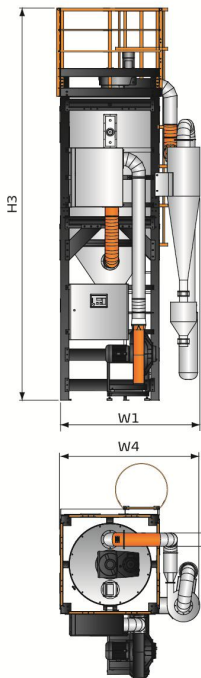

SCR-1600U(Maintenance ladder is optional)

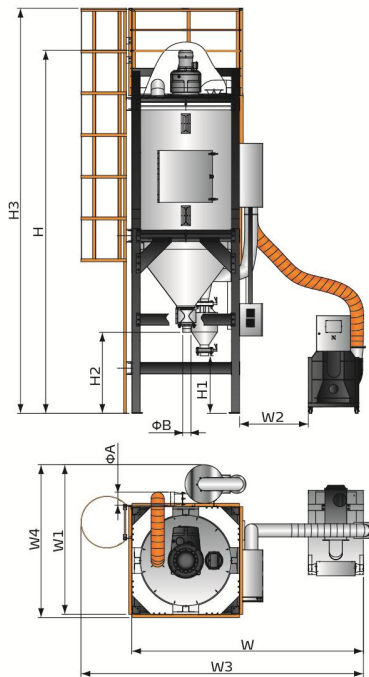
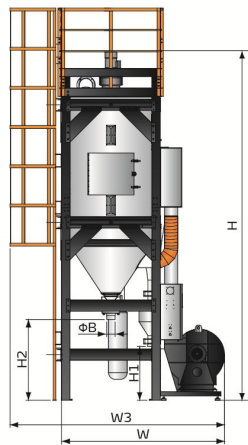

SCR-2500U(Maintenance ladder is optional)

Picture 1-1: Outline Drawing

1.4 Safety Regulations



Note!

Please abide by the safety guide when you operate the machine so as to prevent damage of the machine and personal injuries.

1.4.1 Safety Signs and Labels



All electrical components should be installed by qualified electricians.
Turn off main switch and control switch during repair and maintenance.



Warning! High voltage!

This mark is attached on the cover of the control box.



Warning! Be careful!

Be more careful when this mark appears.



Attention!

No need for regular inspection because all the electrical parts in the control unit are fixed tightly!

1.4.2 Transportation and Storage of the Machine

Transportation

- 1) SCR series are packed in crates or plywood cases with wooden pallet at the bottom, suitable for quick positioning by fork lift.
- 2) After unpacked, castors equipped on the machine can be used for ease of movement.
- 3) Do not rotate the machine and avoid collision with other objects during transportation to prevent improper functioning.
- 4) The structure of the machine is well-balanced, although it should also be handled with care when lifting the machine for fear of falling down.
- 5) The machine and its attached parts can be kept at a temperature from -25°C to $+55^{\circ}\text{C}$ for long distance transportation and for a short distance, it can be transported with temperature under $+70^{\circ}\text{C}$.

Storage

- 1) SCR series should be stored indoors with temperature kept from 5°C to 40°C and humidity below 80%.
- 2) Disconnect all power supply and turn off main switch and control switch.
- 3) Keep the whole machine, especially the electrical components away from water to avoid potential troubles caused by the water.
- 4) Plastic film should be used to protect the machine from dust and rains.

Working environment

Indoors in a dry environment with max. temperature +45°C and humidity no more than 80%.

Do not use the machine

- 1) If it is with a damaged cord.
- 2) On a wet floor or when it is exposed to rain to avoid electrical shock.
- 3) If it has been dropped or damaged until it is checked or fixed by a qualified serviceman.
- 4) This equipment works normally in the environment with altitude within 3000m.
- 5) At least a clearance of 1m surrounding the equipment is required during operation. Keep this equipment away from flammable sources at least two meters.
- 6) Avoid vibration, magnetic disturbance at the operation area.

Rejected parts disposal

When the equipment has run out its life time and can not be used any more, unplug the power supply and dispose of it properly according to local code.

Fire hazard



In case of fire, CO₂ dry powder fire extinguisher should be applied.

1.5 Exemption Clause

The following statements clarify the responsibilities and regulations born by any buyer or user who purchases products and accessories from Shini (including employees and agents).

Shini is exempted from liability for any costs, fees, claims and losses caused by reasons below:

1. Any careless or man-made installations, operation and maintenances upon machines without referring to the Manual prior to machine using.
2. Any incidents beyond human reasonable controls, which include man-made vicious or deliberate damages or abnormal power, and machine faults caused by irresistible natural disasters including fire, flood, storm and earthquake.
3. Any operational actions that are not authorized by Shini upon machine, including adding or replacing accessories, dismantling, delivering or repairing.
4. Employing consumables or oil media that are not appointed by Shini.

2. Structure Characteristics and Working Principle

2.1 Working Principle

Once material filling starts, heat blower starts up and material heating begins. Control cabinet would stop sending signals to auto loader when material filling amount is higher than material level switch. Then material heating lasts for a while. When temperature sensing needle detects the value of reaching the set crystallized temperature, material would be conveyed out via feeding device; meanwhile, as material level in hopper lowers gradually, filling device starts to supply the uncrystallized material accordingly to realize the continuous crystallization process.

When temperature sensing needle detects the temperature value of stopping material conveying, feeding device halts. If temperature rises again to reach the set crystallized temperature, feeding device will be activated to work so that the continuous crystallization process can be realized through this kind of circle.

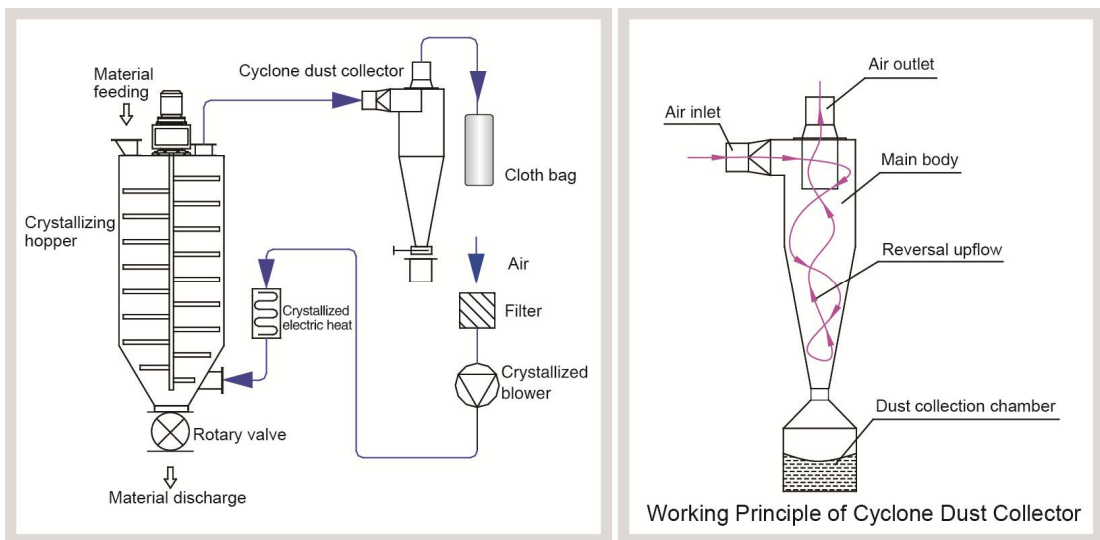

Picture 2-1: Working Principle

3. Installation and Debugging

This series of models only could be applied in working environment with good ventilation.

Before installation, please read the this chapter. Install the machine by the following steps!



Power supply should be fixed by professional technicians only!

3.1 Installation of SCR

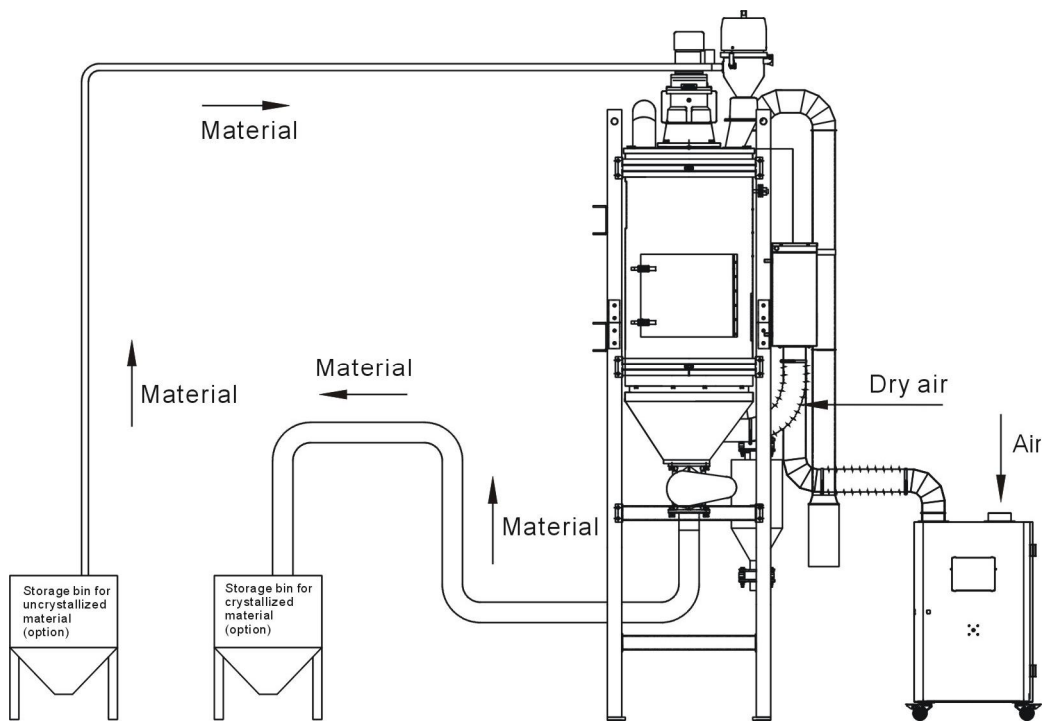

Picture 3-1: Installation of SCR

Power Supply

Make sure that the power supply conforms with required specifications before installation. SCR series are generally set to be used with 3Φ400VAC 50Hz power supply or other specifications if required.



Picture 3-2: Machine Ins Tallation Distance



Note!

Keep the machine 1M from the combustibile distance.

4. Application and Operation

4.1 Description of Control Panel

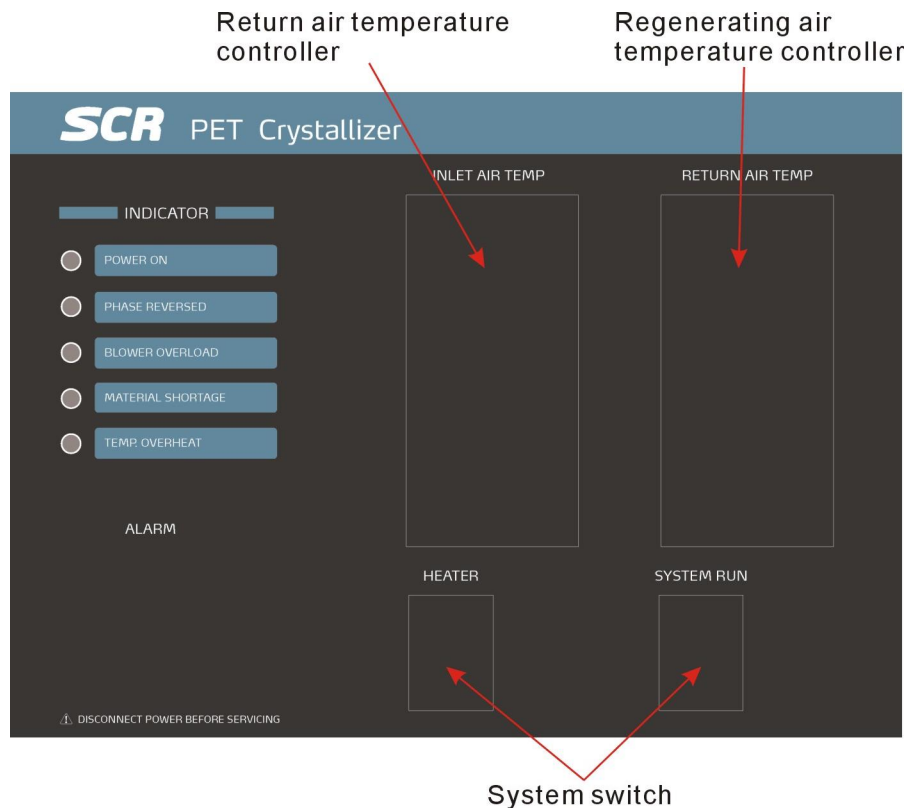

4.2 Start / Stop of the Machine

The start / stop of the machine is controlled by the system switch on the control panel.

4.3 Operation of the Machine

- 1) Turn on the main power switch.
- 2) Set the temperature of regenerating and return air. (Set regenerating temperature at 160°C, and return air temperature at 93°C).
- 3) Turn on the system switch, and the machine starts working.

4.4 Main Operation Processes

- 1) Connect the power supply: connect the three-phase power and open the main power switch, and then, the power indicator in the control panel is blinking and shows the power is on. If there is converse-alarm, please cut off the power supply, and use double power supply lines to instead of the previous one. Then, follow the foregoing instructions, redo the operations.
- 2) Press switch S1, the system goes into the working condition. After the temperature controller indicates the power on, agitator begins to work. The control box will send out a signal to material suction motor to fill up the hopper. (Use crystallized material every time you start the machine). When the material level reaches the level sensor, control box will stop materials feeding.
- 3) Set the temperature controller: 1. Temperature controller (K10) measures the vent temperature of the crystallizer. Set the alarm 1 of K10 to 'the upper limit alarm', the alarming value is 0°C; Set the alarm 2 to 'the upper limit alarm', and the alarming value is -22°C; Set 93°C to the setting temperature of the temperature controller K10. (These settings control discharging. When the temperature reached 93°C, crystallizer will begin to discharge materials; when the temperature is under 71°C, discharging will be stopped); 2. Temperature controller (K8): setting temperature is 160°C (the inlet temperature of crystallizer).
- 4) Press switch button S2 for heating up material. After one hour, open the switch of material discharging motor. When the temperature of return air comes to 93°C (200°F), the control box will send a signal to material discharging motor for discharging. As soon as material discharging begins, material level lowers, which will set material level sensor in motion. Material suction motor will then begin adding uncrystallized material. Afterwards the crystallizer starts a continuous process of material crystallizing.
- 5) At the time when discharged material is too much than materials loaded. That means there is not enough time for material crystallizing, which will lead to a drop of return air temperature. When return air temperature reduces to 71°C (160°F), the control box will stop material discharge motor which will be started again when return air temperature reaches 93°C (200°F).
- 6) Before stopping the crystallizer, please turn off the material suction motor first. Discharging materials only after they are crystallized.

5. Trouble-shooting

Fault	Possible reasons	Solution
It doesn't start after turning on the main switch.	Disconnect from the power supply. Power switch is broken. Power cable is fault. The fuse of control electricity line is broken. Control transformer is broken.	Connect to the power supply. Change the power supply switch. Check the lines of power. Change the fuse after checking the lines. Change the transformer.
After turning on the power supply switch, the power supply indication light is on, but the reverse phase indication light is also on and the buzzer sounds an alarm.	The voltage of power supply is too low. Lack of phase. The connective phase sequence is wrong.	Check the power supply. Exchange the position of any two input lines of power supply.
The rotation motor cannot run.	Contactor of rotation motor is fault. Rotation motor is fault. Circuit is fault.	Change the contactor. Check and change the motor. Check the circuit.
The crystallizer is not full, but the material compensation and absorption machine cannot run; or crystallizer is full, but the material compensation and absorption machine cannot stop.	Electricity lines are fault. Capacitance switch are not adjusted properly or fault.	Check the lines. Adjust the capacitance switch or change it.
The crystallizer doesn't unload materials for a long time, or unloads before the materials are crystallized.	Check the setting of the temperature control meter. Lines fault. Other reasons.	Temperature controller K10 detects the air-outlet's humidity of the crystallizer. Set the K10 alarm 1 to 00C, alarm 2 to 'the last line alarm', and its alarm value is -220C. the setting temperature of K10 is 930C. Temperature controller K8 detects the air-outlet's temperature of the crystallizer, and the setting value is 1600C.
Motor does not work long after material discharged.	Not turn on main switch or system switch or poor connection of the switches.	Turn on the main switch or system switch or reconnect the switches.
	Problems of material level switch.	Adjust or replace.
	Broken of signal wire.	Reconnect.
Motor continues working after hopper full loaded.	Contactor problems.	Repair or replace contactor.

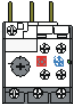
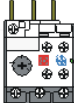
Fault	Possible reasons	Solution
Can not full load the hopper for several times or material shortage alarm lit up.	Material has used up.	Add new material.
	Leakage in the conveying hose.	Lock tight the hose or replace.
	Blocking of filter screen.	Clean the filter screen.
Motor failures	Phase shortage or motor burnt out.	Check or replace.
Fuse melts when turn on the machine.	Short circuit or motor burnt out.	Check the circuit.
Motor overload alarm lit up.	Blocking of filter.	Clean the filter and press Reset on the overload relay. 
	Short of phase.	Press Reset on the overload relay after check the circuit. 

6. Maintenance and Repair

Clear off the dust on the motor fan regularly; avoid the damage to the blower.

SCR-160U

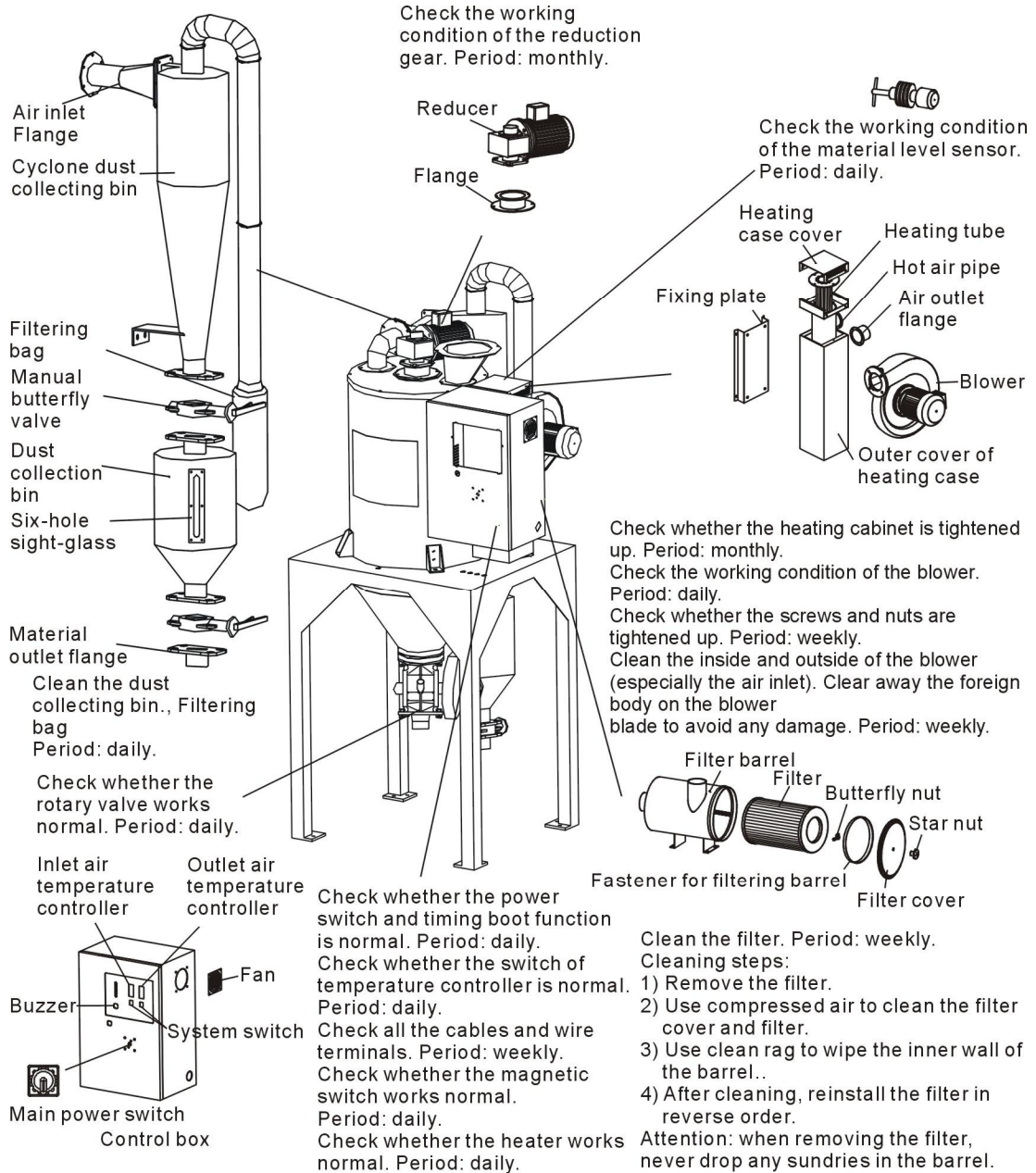

SCR-450U and Models Above

Check the working condition of the reduction gear.
Period: monthly.

Heat-resistant air pipe

Tube bundle

Check whether there is damage, leakage or loose on the heat-resistant air pipe.

Check whether the rotary valve works normal. Period: daily.

Inlet air temperature controller Outlet air temperature controller

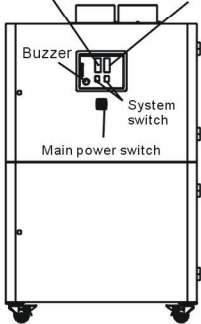

Check whether the power switch and timing boot function is normal. Period: daily.
Check whether the switch of temperature controller is normal. Period: daily.
Check all the cables and wire terminals. Period: weekly.
Check whether the magnetic switch works normal. Period: daily.
Check whether the heater works normal. Period: daily.

Check the working condition of the material level sensor.
Period: daily.

Air inlet Flange

Cyclone dust collecting bin

Filtering bag

Manual butterfly valve

Dust collection bin

Six-hole sight-glass

Material outlet flange

Clean the dust collecting bin, filtering bag
Period: daily.

Filter barrel

Filter

Butterfly nut

Star nut

Fastener for filtering barrel Filter cover

Clean the filter. Period: weekly.
Cleaning steps:

- 1) Remove the filter.
 - 2) Use compressed air to clean the filter cover and filter.
 - 3) Use clean rag to wipe the inner wall of the barrel..
 - 4) After cleaning, reinstall the filter in reverse order.
- Attention: when removing the filter, never drop any sundries in the barrel.

Clean the inside and outside of the blower and clear away the foreign body on the blower blade to avoid any damage.
Period: Weekly.

6.1 Filter

Regularly clean the filter. (Once a week)

Cleaning steps:

- 1) Take out the filter.
- 2) Use compressed air to clean the filter cover and filter.
- 3) Use clean rag to clean the inner wall of the barrel.
- 4) Reinstall the filter after cleaning.

Note: Do not let any impurities fall into the filter barrel when you take out the filter.

6.2 Blower

- 1) Clear up inside and outside of the blower at times. If there are too much dirt accumulated on the blower, the function of the blower will be affected, such as temperature rising, reduced air volume and higher noise level due to vibration. All the above factors are liable to cause mechanical problems.
- 2) The bearing, seal ring and silencer are all consumable parts. They should be replaced after a period of time. And also the fans, covers, and metal grids need to be changed when necessary.

6.3 Maintenance Schedule

6.3.1 About the Machine

Model _____ SN _____ Manufacture date _____

Voltage _____ Φ _____ V Frequency _____ Hz Power _____ kW

6.3.2 Check After Installation

- Check that the conveying pipes are tightly locked.
- Check that the material clearance door is firmly closed.
- Check that the conveying pipes are correctly connected.

Electrical Installation

- Voltage: _____ V _____ Hz
- Fuse melting current: One-phase: _____ A Three-phase: _____ A
- Check the phase frequency of power supply.
- Check rotating direction of the blower.

6.3.3 Daily Checking

- Check the switches of the machine.
- Check the performance of the machine.

6.3.4 Weekly Checking

- Check all the electrical wires.
- Check if there are loose electrical connections.
- Check and clean air filter.
- Check motor overload relay.

6.3.5 Monthly Checking

- Check that the pipe heater is working properly.
- Check the performance of blower.
- Check the functions of electrical components.

6.3.6 Half-yearly Checking

- Check if there are damages of heat-resistant hose or not.
- Check the process heater.
- Check the blower.