

STM

Oil Heater

Date: Jun.,2023

Version: Ver.I (English)



Contents

1. General Description	7
1.1 Coding Principle.....	8
1.2 Feature	8
1.3 Options	8
1.4 Reference Formula of Mould Controllers Model Selection.....	10
1.5 Safety Regulations.....	10
1.5.1 Safety Signs and Labels.....	10
1.5.2 Signs and Labels.....	11
1.5.3 Operation Regulations.....	12
1.6 Exemption Clause.....	13
2. Structure Characteristics and Working Principle.....	14
2.1 Working Principle.....	14
3. Installation and Debugging	15
3.1 Installation Space.....	15
3.2 Pipe Connection.....	15
3.3 Power Connection.....	16
3.4 Options Installation	16
3.4.1 Installation Steps for Options Water Manifold (Dewaxing).....	16
3.4.2 Installation Steps for Options Water Manifold (Welding)	17
4. Application and Operation.....	18
4.1 Machine Startup.....	18
4.2 Main Screen.....	18
4.2.1 Standby Screen	18
4.2.1 Operation Screen	20
4.3 Machine Start/Stop	20
4.3.1 Startup steps	20
4.3.2 Shutdown steps	21
4.4 User Setting	21
4.4.1 User Parameter Settings	21
4.4.2 Action Setting	22
4.4.3 Clock Timing.....	23
4.4.4 System Setting	24

4.4.5	Data Download.....	25
4.4.6	Advanced Setting	26
4.5	Current Fault Inquiry	32
4.6	Inquiry Screen.....	33
4.6.1	History Fault Inquiry.....	33
4.6.2	Inquiry Screen	33
5.	Trouble-shooting.....	36
6.	Maintenance and Repair	38
6.1	Open the Covers.....	39
6.2	Y Type Strainer	40
6.3	Solenoid Valve	40
6.4	Pipe Heater	41
6.5	Cooling Pipes.....	41
6.6	Maintenance Schedule	43
6.6.1	About the Machine.....	43
6.6.2	Installation & Inspection.....	43
6.6.3	Daily Checking	43
6.6.4	Weekly Checking.....	43
6.6.5	Trimonthly Checking.....	43
6.6.6	Half-yearly Checking	44
6.6.7	Yearly Checking	44
6.6.8	3 year Checking	44

Table Index

Table 3-1:	Cooling Water Inlet and Outlet Specification	16
Table 4-1:	Standby Screen Specifications.....	19
Table 4-2:	Operation Screen Specification	20
Table 4-3:	User Parameter Specification.....	22
Table 4-4:	Project Parameter Description.....	27
Table 4-5:	Current Fault Inquiry Screen Icon Key Description.....	32

Picture Index

Picture 1-1: Oil HeaterSTM-1220	7
Picture 2-1: Working Principle	14
Picture 3-1: Installation Space.....	15
Picture 3-2: Pipe Connection	15
Picture 4-1: Startup Screen.....	18
Picture 4-2: Standby Screen	18
Picture 4-3: Operation Screen	20
Picture 4-4: User Setting Screen	21
Picture 4-5: User Parameter Screen.....	22
Picture 4-6: Action Setting Screen	22
Picture 4-7: Clock Timing Screen.....	23
Picture 4-8: Set Timing Switch Screen.....	24
Picture 4-9: Timer Inquiry and Modification Screen	24
Picture 4-10: System Setting Screen	25
Picture 4-11: Data Download Screen.....	25
Picture 4-12: Temp. Data Download Screen.....	25
Picture 4-13: Alarm Record Download Screen.....	26
Picture 4-14: Project Screen	26
Picture 4-15: Project Parameter Setting Screen	27
Picture 4-16: Password Mgmt. Screen.....	30
Picture 4-17: Interface Specification	31
Picture 4-18: Comm. Parameter Settings	32
Picture 4-19: Current Fault Screen	32
Picture 4-20: History Fault Inquiry Screen	33
Picture 4-21: User Setting Screen.....	33
Picture 4-22: Data Inquiry Screen	34
Picture 4-23: Output Inquiry Screen.....	34
Picture 4-24: Input Inquiry Screen.....	34
Picture 4-25: Version Inquiry Screen	35
Picture 6-1: Open the Covers 1	39
Picture 6-2: Open the Covers 2	39
Picture 6-3: Open the Covers 3	40
Picture 6-4: Y Type Strainer	40

Picture 6-5: Solenoid Valve	41
Picture 6-6: Pipe Heater 1	41
Picture 6-7: Pipe Heater 2	41
Picture 6-8: Cooling Pipes 1	42
Picture 6-9: Cooling Pipes 2	42

1. General Description



Read this manual carefully before operation to prevent damage of the machine or personal injuries.

The STM-O series oil heaters are used to heat up the mould and maintain this temperature, although they can be used in other similar applications. High temperature oil from the mould is sent to the moulds after pressurized by the pump and heated up by the pipe heater through indirect cooling of the cooler, so as to heat up and maintain constant temperature. It adopts new temperature controller that can ensure stable temperature control.



Picture 1-1: Oil HeaterSTM-1220

1.1 Coding Principle

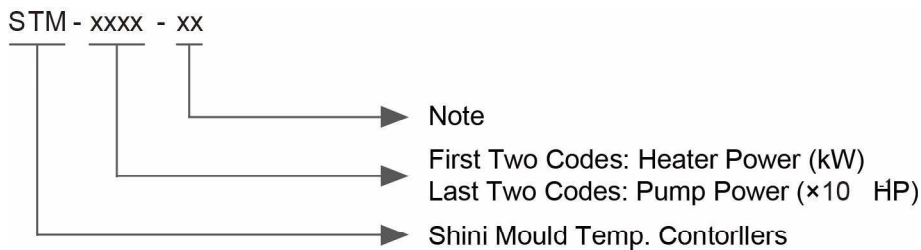

1.2 Feature

- For standard STM, the maximum heating temperature can reach up to 200°C /392°F, while the maximum heating temperature of STM-HT can reach 300°C/572°F.
- P.I.D controller with 4.3" LCD with a intuitive and user-friendly interface.
- Weekly timer with °C/0.9°F unit conversion.
- Adopt digital P.I.D. multi-stage controller can maintain stable mould temperature with a precision of $\pm 0.5^{\circ}\text{C}/0.9^{\circ}\text{F}$.
- SSR solid state relay
- STM in build an efficient high temperature pump. STM-HT is equipped with magnetic pump, and the interior is made of stainless steel for high pressure explosion-proof without leakage;
- In build multiple safety plus warning devices, such as reverse phase, pump overload, overheat, and low oil level alarm.
- Stainless steel pipe heater.
- Standard equipped with flow display and pump reverse function for oil return.
- RS485 communication interface achieves centralized monitoring with the host.
- Standard buzzer

1.3 Options

- Displays of mould temperature and return oil temperature of mould are optional, and add "TS" at the end of the model code.
- For models optional with magnetic pump (excluded for STM-3650 and

STM-D models), add “M” at the end of the model code.

- It could option with magnetic filter to prolong service life of magnetic pump (only suitable for models with magnetic pump). Add “MF” at the end of the model code.

All service work should be carried out by a person with technical training or corresponding professional experience. The manual contains instructions for both handling and servicing. Chapter 6, which contains service instructions intended for service engineers. Other chapters contain instructions for the daily operator.

Any modifications of the machine must be approved by SHINI in order to avoid personal injury and damage to machine. We shall not be liable for any damage caused by unauthorized change of the machine.

Our company provides excellent after-sales service. Should you have any problem during using the machine, please contact the company or the local vendor.

Shini HotlineService:

Headquarter and Taipei factory:

Tel:+886 (0)2 2680 9119

Shini Plastics Technologies (Dongguan), Inc.:

Tel: +86 (0)769 8331 3588

Shini Plastics Technologies (Pinghu), Inc.:

Tel: +86 (0)573 8522 5288

Shinden Precision Machinery (Chongqing), Inc.:

+86 (0)23 6431 0898

1.4 Reference Formula of Mould Controllers Model Selection

Heater Power (kW) = mould weight (kg) × mould specific heat (kcal/kg°C) × temperature difference between mould and environment (°C) × safety coefficient / heating duration / 860

Note: safety coefficient can select a value from 1.3 to 1.5.

Flow Rate (L/min) = heater power (kw) × 860 / [heating medium specific (kcal/kg°C) × heating medium density (kg/L) × in/outlet temperature difference (°C) × time (60)]

Note: Water specific heat =1kcal/kg°C

Heating medium oil specific heat =0.49kcal/kg°C

Water density =1kg/L

Heating medium oil density =0.842kg/L

1.5 Safety Regulations

Strictly abide by the following safety regulations to prevent damage of the machine or personal injuries.

1.5.1 Safety Signs and Labels



Danger!

The unit is designed to endure high temp, and high pressure. For safe operation, do not remove the covers or switches.



Attention!

The unit should be operated by qualified personnel only.

During operation, avoid wearing gloves or clothes that may cause danger.

Turn off main switch when power supply is off.

Stop the unit when there may be power supply problems caused by static electricity.

Put on safety gloves and shoes during installation or relocation.

Components from our company can only be used for replacement.



Warning!

Do not touch the switch with wet object or hands.

Do not use the machine before fully aware of its performance.

Be careful not to touch or hit the switch or sensor.

Please keep enough operation space, and keep away obstacles.

To avoid producing statics, clean the floor from oil or water to keep a dry environment.

Protect the machine against severe vibration or collision.

Do not remove safety signs or make it dirty.

Drunken, medicine-taking, or men without proper judgement should not operate the machine.







Warning!

High temperature, take care of hands! This label is attached on the surface of heating parts.

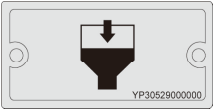
1.5.2 Signs and Labels

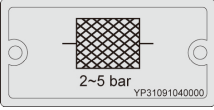
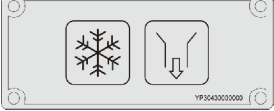
<table border="1"> <thead> <tr> <th>Item</th> <th>CT</th> </tr> </thead> <tbody> <tr> <td>Check whether the pipeline joints are under looseness.</td> <td>Weekly</td> </tr> <tr> <td>Clean the Y-type filter.</td> <td>Weekly</td> </tr> <tr> <td>Clean the solenoid valve.</td> <td>Monthly</td> </tr> <tr> <td>Check the sensitivity of EGO.</td> <td>Weekly</td> </tr> <tr> <td>Check the level switch.</td> <td>Three months</td> </tr> <tr> <td>Check the contactor.</td> <td>Three months</td> </tr> <tr> <td>Clean the process heater/cooler.</td> <td>Three months</td> </tr> <tr> <td>Check the indicator and buzzer.</td> <td>Six months</td> </tr> <tr> <td>Control board</td> <td>Every 3 year exchange</td> </tr> <tr> <td>No fuse breaker</td> <td>Every 3 year exchange</td> </tr> <tr> <td rowspan="3">Thermal oils</td> <td>≤ 120 °C</td> <td>Renew annually</td> </tr> <tr> <td>120 °C - 160 °C</td> <td>Renew every six months</td> </tr> <tr> <td>> 160 °C</td> <td>Renew every three months</td> </tr> </tbody> </table> <p>Note: Please refer to the Manual for detailed operations.</p>	Item	CT	Check whether the pipeline joints are under looseness.	Weekly	Clean the Y-type filter.	Weekly	Clean the solenoid valve.	Monthly	Check the sensitivity of EGO.	Weekly	Check the level switch.	Three months	Check the contactor.	Three months	Clean the process heater/cooler.	Three months	Check the indicator and buzzer.	Six months	Control board	Every 3 year exchange	No fuse breaker	Every 3 year exchange	Thermal oils	≤ 120 °C	Renew annually	120 °C - 160 °C	Renew every six months	> 160 °C	Renew every three months	<p>Please according to schedule to make regular maintenance.</p>
Item	CT																													
Check whether the pipeline joints are under looseness.	Weekly																													
Clean the Y-type filter.	Weekly																													
Clean the solenoid valve.	Monthly																													
Check the sensitivity of EGO.	Weekly																													
Check the level switch.	Three months																													
Check the contactor.	Three months																													
Clean the process heater/cooler.	Three months																													
Check the indicator and buzzer.	Six months																													
Control board	Every 3 year exchange																													
No fuse breaker	Every 3 year exchange																													
Thermal oils	≤ 120 °C	Renew annually																												
	120 °C - 160 °C	Renew every six months																												
	> 160 °C	Renew every three months																												
<p>YP30424000000</p>	<p>Oil outlet valve: oil discharge outlet for renewing oil.</p>																													
<p>YP30428000000</p>	<p>High liquid level: the highest oil level to which machine can reach under room temperature.</p>																													
<p>YP30422000000</p>	<p>From mould: connector for circulating water/oil coming from mould.</p>																													

	<p>To mold: connector for circulating water/ oil to go to mould.</p>
	<p>Oil inlet: oil filler for machine.</p>
	<p>Overflow</p>
 <p>2~5 bar</p>	<ol style="list-style-type: none"> 1. To maintain temperature consistency, cooling water pressure must be higher than 2 bar at all time, but should never exceed 5 bar in any case. 2. Clean Y-shape Cooling Water Strainer periodically to ensure perfect cooling capacity.
	<p>Water outlet: drainage outlet.</p>
	<p>Water inlet: inlet for cooling water.</p>
	<p>Overflow port: The overflow port used when for the tank oil level exceeds the safety position.</p>

1.5.3 Operation Regulations

- 1) Before operation, make sure that cooling water is clean soft water without pollutants.
 - ※ Low quality water brings limescales, which may cause problems.
- 2) If problems of drainage or bad temperature control are noted, please clean solenoid valve and cooling water inlet and outlet.
- 3) Do not move the unit when it is in operation.
- 4) When in need of repairing, wait until oil temperature falls below 30°C.
- 5) The oil heater has pump overload device: When it is overloaded, the pump and pipe heater will both stop. At this time, check the cause of pump overload (phase loss, pipe blockage, bearing damage, etc.). After

everything is normal, reset the overload protector (RESET) to resume work.

- 6) Before turn off the pump, wait until oil temperature falls below 50°C. Or the life of the unit would be affected.

1.6 Exemption Clause

The following statements clarify the responsibilities and regulations born by any buyer or user who purchases products and accessories from Shini (including employees and agents).

Shini is exempted from liability for any costs, fees, claims and losses caused by reasons below:

- 1) Any careless or man-made installations, operation and maintenances upon machines without referring to the Manual prior to machine using.
- 2) Any incidents beyond human reasonable controls, which include man-made vicious or deliberate damages or abnormal power, and machine faults caused by irresistible natural disasters including fire, flood, storm and earthquake.
- 3) Any operational actions that are not authorized by Shini upon machine, including adding or replacing accessories, dismantling, delivering or repairing.
- 4) Employing consumables or oil media that are not appointed by Shini.

2. Structure Characteristics and Working Principle

2.1 Working Principle

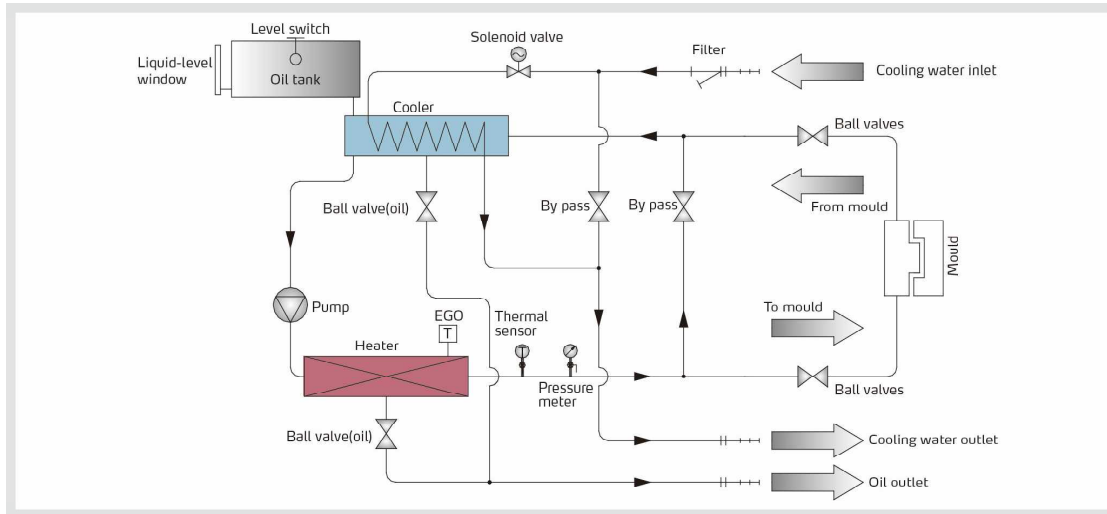

Picture 2-1: Working Principle

The high temperature oil returns to the machine and then be pressured by pump to the heater. After being heated, oil will be forced to the mould and continue the circle. In the process, if the oil temperature is too high, system will activate the solenoid valve to let cooling water cool down high temperature oil indirectly until the temperature is down to the system requirement. If the temperature keeps increasing and reaches to the set point of EGO, the system will sound alarm and stop operation. The system will have low level alarm and stop working if oil level falls down below the set point.

3. Installation and Debugging

3.1 Installation Space

During installation of the machine, keep at least 500mm installation space around the machine as shown by the picture. Do not install the machine in a position crowded with other objects. This would cause inconvenience to operation, maintenance and repair.

Do not sit on the machine.

Keep away flammable and explosive goods.



Picture 3-1: Installation Space

3.2 Pipe Connection

- 1) The inlet and outlet specifications of the heating tank and return oil pipe
STM-607/910(STM-607M/910M): 3/4"PT female thread
STM-1220/2440(STM-1220M/2440M): 1"PT female thread
STM-3650: 1.25"PT female thread
- 2) Cooling Water Connection



Picture 3-2: Pipe Connection

Table 3-1: Cooling Water Inlet and Outlet Specification

Model	Cooling Water Inlet	Cooling Water Outlet	Connector Type
STM-607/910 STM-607M/910M	Φ13mm(ext. diameter)	Φ13mm(ext. diameter)	Pagoda
STM-1220/2440 STM-1220M/2440M	Φ13mm(ext. diameter)	Φ13mm(ext. diameter)	Pagoda
STM-3650	Φ13mm(ext. diameter)	Φ13mm(ext. diameter)	Pagoda

3.3 Power Connection

The water heater needs well electrical grounding to ensure safe running of the electrical equipments.

- 1) Make sure the voltage and frequency of the power source comply with those indicated on the manufacturer nameplate that attached to the machine.
- 2) Power cable and earth connection should conform to your local regulations.
- 3) Use independent electrical wires and power switch. Diameter of electrical wire should not be less than those used in the control box.
- 4) The power cable connection terminals should be tightened securely.
- 5) The machine requires 3-phase 4-wire power source, connect the power lead (L1, L2, L3) to the live wires, and the earth (PE) to the ground.
- 6) Power supply requirements:
Main power voltage: +/- 5%
Main power frequency: +/- 2%
- 7) ***Please refer to electrical drawing of each model to get the detailed power supply specifications***

3.4 Options Installation

3.4.1 Installation Steps for Options Water Manifold (Dewaxing)

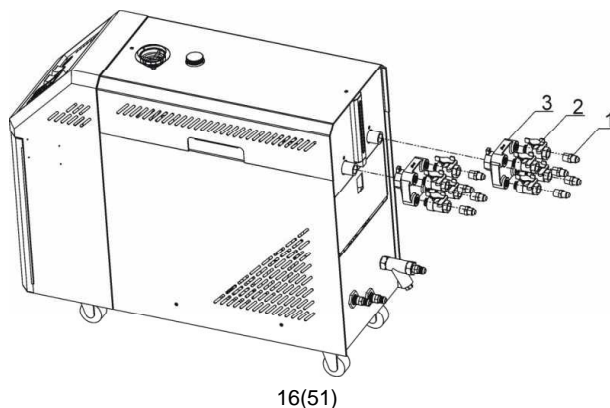

- 1) Install copper joint to the level valve.
- 2) Install level valve with copper joint to the dewaxing water manifold.
- 3) Install water manifold to the machine.
- 4) Install Teflon to copper joint.

Note: For the operating temperature not higher than 200°C, Teflon with temperature resistance 200°C is usable; for the operating temperature from 200 to 300°C, must use Teflon with temperature resistance 300°C.

3.4.2 Installation Steps for Options Water Manifold (Welding)

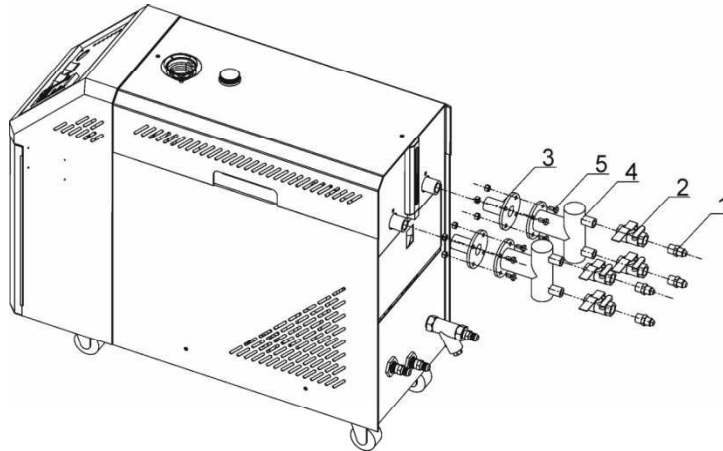

- 1) Install copper joint to the level valve.
- 2) Install level valve with copper joint to the welding water manifold.
- 3) Install water manifold to the machine.
- 4) Connect water manifold with manifold joint via screws.
- 5) Install Teflon to copper joint.

Note: For the operating temperature not higher than 200°C, Teflon with temperature resistance 200°C is usable; for the operating temperature from 200 to 300°C, must use Teflon with temperature resistance 300°C.

4. Application and Operation

4.1 Machine Startup

After the system is powered on, the panel displays the startup screen, as below:



Picture 4-1: Startup Screen



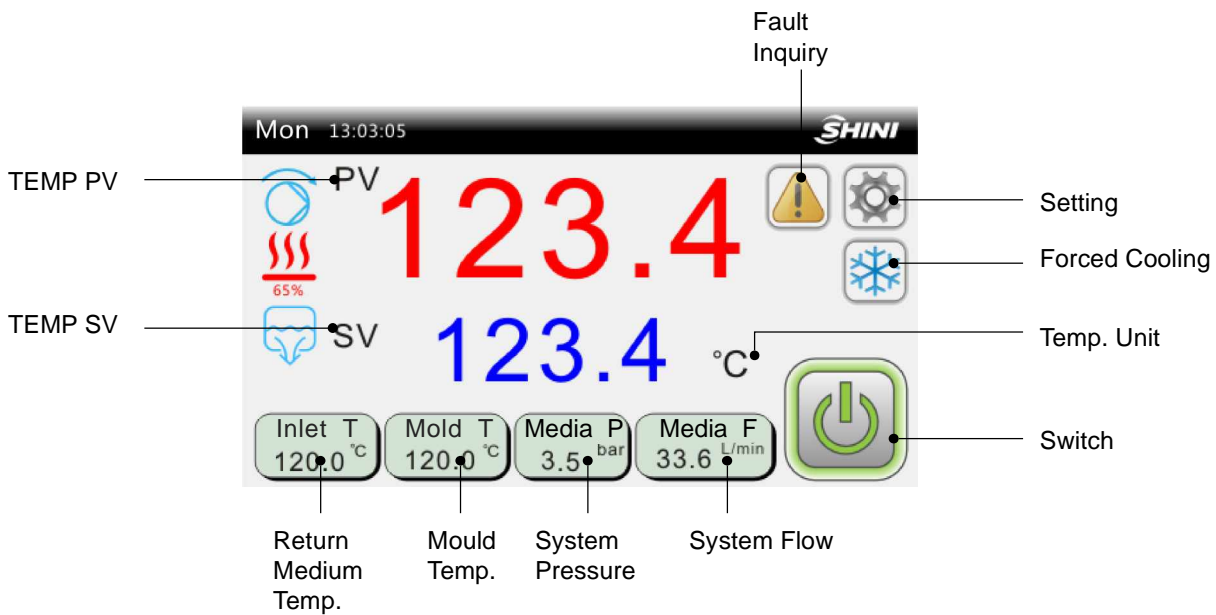

4.2 Main Screen

4.2.1 Standby Screen



Picture 4-2: Standby Screen

Table 4-1: Standby Screen Specifications

Name	Function Type	Description
Setting	key	Enter the user setting screen
Forced cooling	button	 Start the forced cooling function  Stop the forced cooling function
Temp. unit	only display	Display the set temp. unit. The unit supports °C/°F shifting.
Fault inquiry	key	<ol style="list-style-type: none"> When the system fails, the main interface will flicker. At this time, click to check current fault info.; When no fault occurs at current, press it to inquire the "Historical Fault".
Switch	key	 Standby status  Running status
Return medium temp.	only display	Display the medium temp. returned from the mould, which is optional. When not selecting this function, all displays are gray.
Mould temp.	only display	Display the mould present temp., which is optional. When not selecting this function, all displays are gray.
System pressure	only display	Display the medium output pressure, which is optional. When not selecting this function, all displays are gray.
System flow	only display	Display the medium present pressure, which is optional. When not selecting this function, all displays are gray.
Temp. SV	key	Set the heating temp.
TEMP PV	only display	Display the control temp. PV

4.2.1 Operation Screen

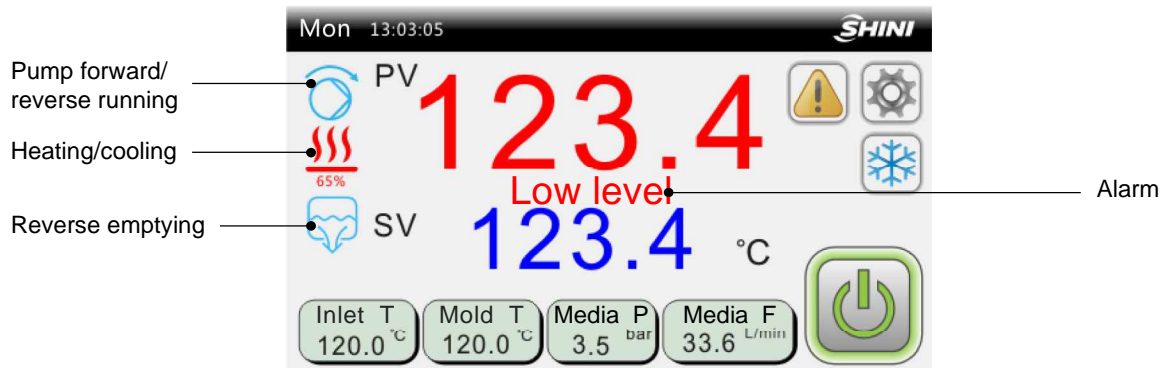

Picture 4-3: Operation Screen

Table 4-2: Operation Screen Specification

Items	Description
Pump forward / reverse running	the unit starts the pump forward / reverse running
Heating/cooling	It starts the unit temp. controlling and heating function. The bottom is heating percentage.
Reverse emptying	The unit starts emptying function
Alarm	The alarm displayer and indicator are on.

4.3 Machine Start/Stop

4.3.1 Startup steps

- 1) Please check if all pipelines are properly connected, including the cooling water inlet and outlet pipes and heat medium inlet and outlet pipes, and if all inlet and outlet valves are open;
- 2) Add heat transfer oil till the float ball rising microswitch pops up. Please be noted that the oil level should not exceed the level indicated on the label on rear plate of the level indicator.
- 3) Connect through the power, and make sure the voltage and frequency meet the standard marked on the nameplate.
- 4) Turn on the main power switch on the door plate, and the screen will light up;

- 5) Click on the SV on the controller to set the target temp., and at last click on the switch button to start the machine.

4.3.2 Shutdown steps

- 1) Press the<Forced cooling>button to turn off the heating output and turn on 100% cooling.
- 2) When the temperature drops below 50 °C, press the<Forced cooling>button to turn off the forced cooling, and then press the<Run/Stop>button to stop the machine.
- 3) Turn the main power switch to OFF.

Attention:

When the main power switch is ON, please be noted the the risk of electric shock!

Attention:

Make sure the pump running direction is correct!

Attention: In order to reduce machine damage and extend its lifespan, please turn on and off it following correct steps!

4.4 User Setting

In the "Operation" screen, click the <Setting > button to enter the "User Setting" screen:



Picture 4-4: User Setting Screen

4.4.1 User Parameter Settings

In the "User Setting" screen, click the <User Parameters > button to set user parameters:

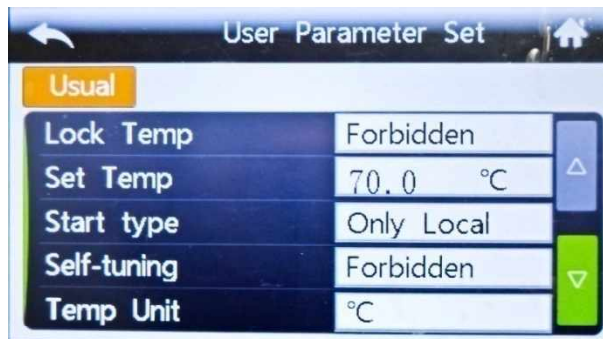

Picture 4-5: User Parameter Screen

Table 4-3:User Parameter Specification

Parameter	Initial Value	Setting Range	Unit	Remarks
Locking temp.	disable	disable- use		When selecting the “use”, it’s not allowed to set temperature on the main interface.
Setting temp.	80.0	0-200.0	°C	
Start/stop mode	local	local~local+ remote ~ remote		Local: unit startup/shutdown can only be controlled locally. Local + remote: unit startup/shutdown can only be controlled locally and remotely. Remote: unit startup/shutdown can only be controlled remotely.
Auto turning	disable	disable- enable		
Temp. Unit	°C	°C/°F		Temp. display unit
Decimal point	0.1	1/0.1		The main screen has mini. temp. unit display

4.4.2 Action Setting

In the "User Setting" screen, click the <Action Setting > button to enter the screen below:



Picture 4-6: Action Setting Screen

After the machine stops, it will start pump reverse running and exhaust valve, which can be started and stopped manually or automatically (The factory default of reversal running time is 60S, and refer to the project parameter table for specific settings).

Notice:

- 1) **If it has to turn on the reverse emptying function during machine running. Turn off the machine at first, and then start the reverse emptying process.**
- 2) **The reverse emptying function of the magnetic oil heater STM-M is unavailable.**

4.4.3 Clock Timing

Click the <Clock Timing > button in the user setting screen to enter the following screen:



Picture 4-7: Clock Timing Screen

Timing main switch: used to select the timing on/off function, and it can inquire on the main screen if the timing is switched on. It can set six groups of time in total, and each group of time can be selected through the switch: disable, timing on or off.

After timing main switch is turned on, it can set the timing on/off, as shown in the picture below:

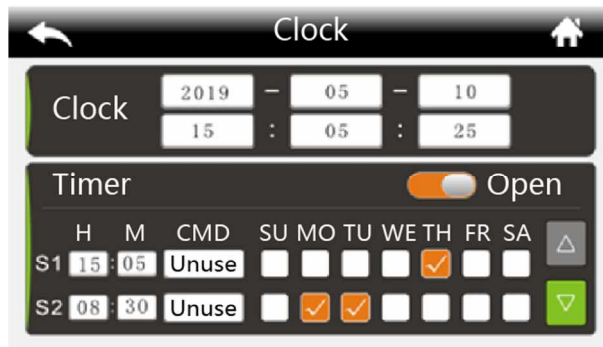

Picture 4-8: Set Timing Switch Screen

If the "Timing Main Switch" is set to "ON", press the <Clock > button in the "Operation" screen to enter the Timing Inquiry and Modification Screen.

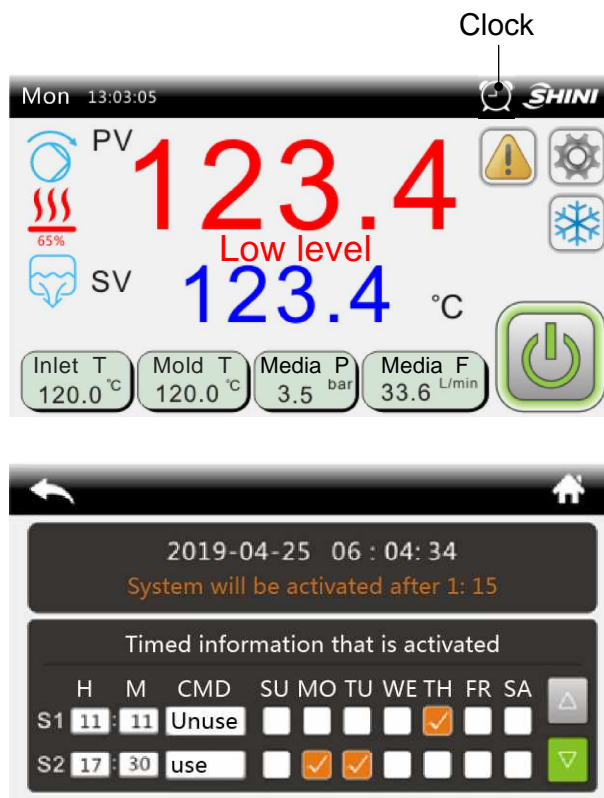

Picture 4-9: Timer Inquiry and Modification Screen

4.4.4 System Setting

In the "User Setting" screen, click the <System Setting > button to enter the picture below:

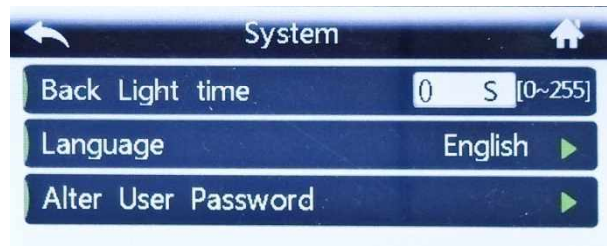

Picture 4-10: System Setting Screen

Set the backlight time: setting range is 0 ~ 255 secs.

Language: Chinese or English

The default user password is 3588. See "Password Modification" for details;

4.4.5 Data Download

When downloading data, please use the U disk format: FAT32, and the recommended U disk capacity is 16g or below.

In the user setting screen, click the <Data Download > button to enter the following screen:

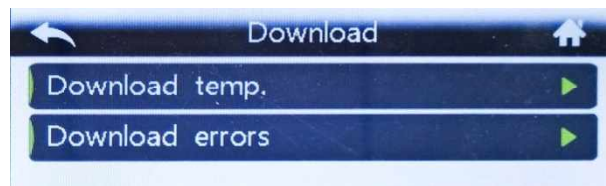

Picture 4-11: Data Download Screen

4.4.5.1 Temp. Data Download



Picture 4-12: Temp. Data Download Screen

Local data backup: copy the temp. data on the display board to the Udisk (the data of display board can be saved for up to 48 hrs.). Copy the temperature data stored on the display board to the USB flash disk. Insert the U disk, wait until the "U disk"

displays "connected" status, and then follow the prompts. Other operations are prohibited during the download process.

Real-time data recording: After inserting the U disk and starting the real-time data recording function, then the temp. data will be updated in real time and stored in the U disk automatically, and the recording will be interrupted after unplugging the U disk. Operations on other screens are available during recording.

 **Attention!**

After data export, a folder/SF51XXX will be created in the U disk root directory, and the data will be saved in Excel.

4.4.5.2 Alarm Record Download



Picture 4-13: Alarm Record Download Screen

4.4.6 Advanced Setting

4.4.6.1 Project Setting

In the "User Settings" screen, click the < Advanced Setting > button and enter the password to enter the "Project" screen.



Picture 4-14: Project Screen

In the "Project" screen, click the <Project Parameter > button to enter the project

parameter setting

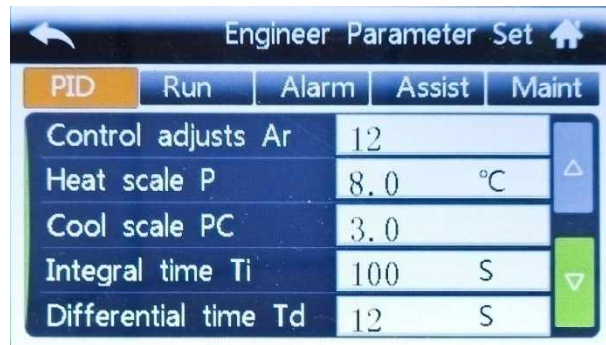

Picture 4-15: Project Parameter Setting Screen

The detailed description of each project parameter is as below Table:

Table 4-4: Project Parameter Description

Running	Probe type	K type	K-type thermocouple/ PT100	/	
	The number of probes	control circuit	Control loop ~ control+ return medium ~control +mould ~control +return medium +mould	/	Control circuit: Control temp. probe only Control+return medium: control temp. +return medium temp. Control+mould: control temp. +mould temp. Control+mould+mould: control temp. + return medium temp. + mould temp.
	Shutdown temp.	35.0	0~60.0	°C	Shut down: The unit shuts down when it is cooled to this temp.
		95.0	32.0-140.0	°F	
Reverse time	6 secs.	0-600 secs.	secs.	Reverse emptying running After the machine stops, start the pump reversing and emptying valve; Manual start/stop or auto run 【reversal time】 and stop is available. Note: If the reverse emptying function is activated during running, the machine will stop at first, and then start the reversal emptying function.	

Fault	3-phase power detection	Use	disable / use	/	Whether it uses the on-board 3-phase power detection;
	Return medium deviation alarm	0.0	0-50.0	°C	<p>1. Return medium temp. – medium output temp. > 【return medium temp. deviation】 , delay 【temp. deviation alarm delay】 secs., it alarms “Large return medium temp. difference”, make auto reset. 0: disable.</p> <p>2. After modifying [SV] or forced cooling, this fault will not be solved in previous temp. rises / drops.</p>
Fault	Different mould temp. alarm	0.0	0-50.0	°C	
		0.0	0-90.0	°F	
	Different temp. alarm delay	5	0-360	secs.	
	Low temp. deviation alarm	0.0	0-50.0	°C	<p>【SV】 –PV > 【Low temp. deviation alarm】 delay two secs., it alarms low temp., 【SV】 –PV < 【low temp. deviation alarm】 , it will reset the fault automatically.</p> <p>When 【Low temp. deviation alarm】 =0, this function is disabled.</p>
		0.0	0-90.0	°F	
High temp. deviation alarm	0.0	0-50.0	°C	<p>PV– 【SV】 > 【High temp. deviation alarm】 delay two secs., it alarms high temp., , PV – 【SV】 < 【High temp. deviation alarm】 , it will reset the fault automatically.</p> <p>When 【High temp. deviation alarm】 =0, this function is disabled.</p>	

	Low flow alarm	0.0	0-100	L/min	Use flow sensor, the medium flow is lower than the [Low flow alarm], it delays two secs., and alarms "Low flow"; 0: disable
	High pressure alarm	0.0	0-50	bar	Use pressure sensor, the medium pressure is high than the [High pressure alarm], it delays two secs., and alarms "High pressure"; 0: disable
Assist	Heater alarm	0.0	0~999	Min.	1. If the machine fails to reach the set temp. of - 5 °C within the [heater alarm] time, it will give the "heater alarm", and continue to control the temp. Manual reset. 2. Set to 0, disable the limit detection.
	Overheat tripping temp. difference	15.0	0~100	°C	PV—【SV】>【overheat trip output temp. difference】, open the circuit breaker, the EGO will alarm;
		9.0	0-180	°F	
	Interference alarm	0.0	0~200.0	°C/ sec.	1. Monitor temp. variation trend 2. The temp. rises or drops exceeds the 【Interference alarm temp.】 per second, it will give "Interference Alarm", and reset the fault automatically. 3. Set to 0: disable.
0.0		0-360.0	°F/ sec.		
Maintenance	Control temp. compensation	0.0	-30.0~30.0	°C	Compensate the measurement error of the medium output temp.
		0.0	-54.0~54.0	°F	
	Return medium temp. compensation	0.0	-30.0~30.0	°C	Compensate the measurement error of the return medium temp.
		0.0	-54.0~54.0	°F	
	Return medium temp. compensation	0.0	-30.0~30.0	°C	Compensate the measurement error of the return medium temp.
		0.0	-54.0~54.0	°F	
	Mould medium temp. compensation	0.0	30.0~30.0	°C	Compensate the measurement error of the mould temp.
		0.0	-54.0~54.0	°F	

	Analog quantityAI1 compensation	0.0	-30.0~30.1	bar	Compensate the pressure measurement error
	Analog quantityAI2 compensation	0.0	-30.0~30.2	L/min	Compensation flowmeasurementerror.
	Comm. address	0	0-31		Comm. basic info. setting
	Baud rate	19200.0	4800,960,019200		
	Check bit	No parity	No parity, even parity check, odd parity		
	Stop bit	1 bit	1 bit, 2 stop bits		
	Comm. address set	SHINI	SHINI、GBT		
Maintenance	Unit maintenance time	0.0	0-3000	hr.	When the setaccumulative running time is greater than [unit maintenance time], it alarms" Unit Maintenance Fault".
	Accumulative total running time (hr.)	0.0	0-3000	hr.	
	Accumulative total running time (min.)	0.0	0-59	Min.	

In the "Project" screen, click <Password Mgmt.> to enter the password mgmt. settings.

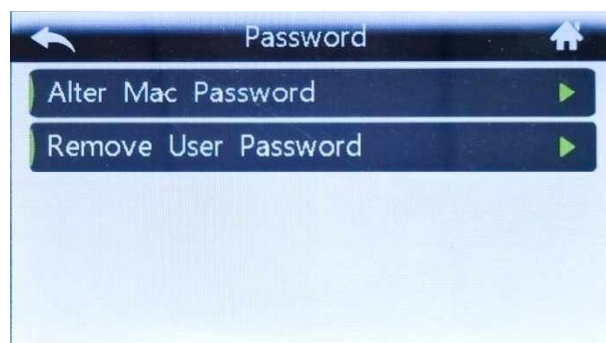

Picture 4-16: Password Mgmt. Screen

1) Project password modification

The default value of the project password is 3588. See "Password Modification" for details.

2) Clear the user password.

It can clear the user password with one click.

4.4.6.2 Shini Communication Method

1) Interface specification and communication definition:

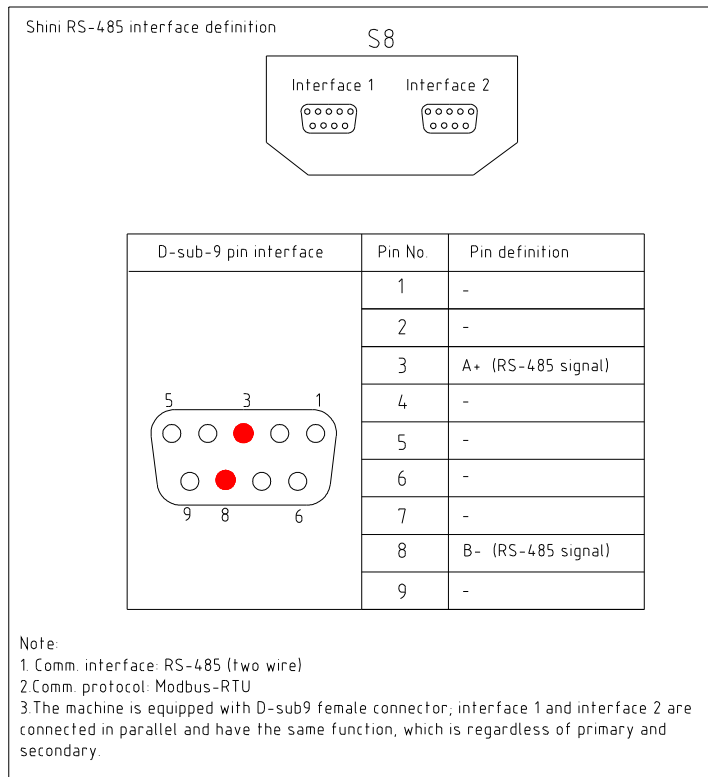

Picture 4-17: Interface Specification

Comm. Protocol:

Communication parameters can be set in "Engineering Settings" - Engineering Parameters - "Auxiliary".

Built-in Modbus- Rtu protocol.

Note:

The communication address, Baud, check bit and stop bit are adjusted according to the actual demands.

2) Comm. address set selection:

SHIINI (default): The address definition of Shini controller (as shown in the Appendix).



Picture 4-18: Comm. Parameter Settings

4.5 Current Fault Inquiry

When the unit fails, in the “Operation” screen, the < Fault Inquiry> button will flicker. At this time, click the <Fault Inquiry > button to silence and enter following screen:

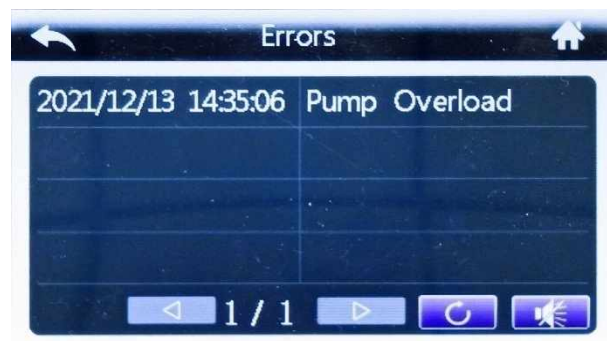

Picture 4-19: Current Fault Screen

Table 4-5:Current Fault Inquiry Screen Icon Key Description

Press Key	Key Name	Description
	Fault reset	After trouble-shooting, press this key to reset the fault.
	Silence	Eliminate the system alarm sound
	Page up	Turn the page to query the fault information, gray key can't be pressed, and green key can be pressed.
	Page down	Turn the page to query the fault information, gray key can't be pressed, and green key can be pressed.

4.6 Inquiry Screen

4.6.1 History Fault Inquiry

When there is no fault currently, click the <Fault Inquiry> button in the "Operation" screen to enter the history fault inquiry.



Picture 4-20: History Fault Inquiry Screen

4.6.2 Inquiry Screen

In the "Operation" screen, click the < Setting > button to enter the "User Setting" screen, and click the < Inquiry > button to enter the inquiry screen.



Picture 4-21: User Setting Screen

4.6.2.1 Data Inquiry

It can check all probes' temperature, pressure of current system, and query the system running time and other data:



Picture 4-22: Data Inquiry Screen

4.6.2.2 Output Inquiry

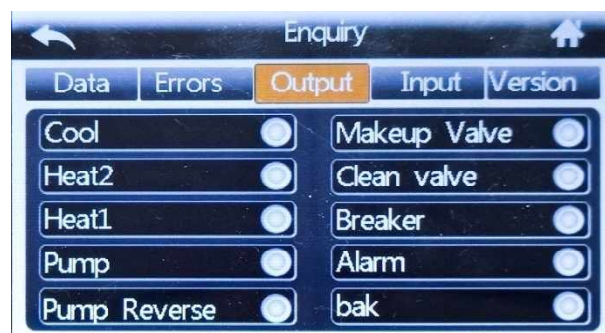

Picture 4-23: Output Inquiry Screen

When the indicator is gray, it means that corresponding relay has no output.

When the indicator light is green, it indicates that corresponding relay is outputting.

4.6.2.3 Input Inquiry



Picture 4-24: Input Inquiry Screen

When the indicator light is gray, it indicates that corresponding switch input is invalid.

When the indicator light is green, it indicates that corresponding switch input is valid.

4.6.2.4 Version Inquiry

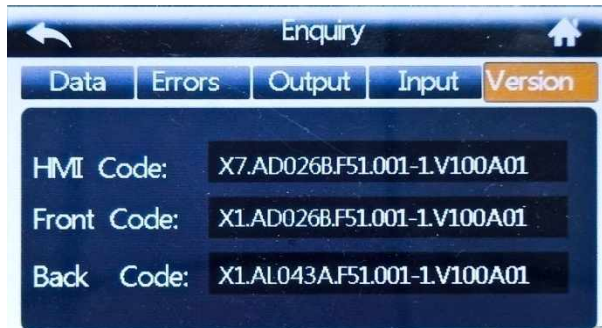

Picture 4-25: Version Inquiry Screen

Take real display value as standard.

5. Trouble-shooting

Failures	Possible reasons	Solutions
LCD displays nothing after switch on power and press ON/OFF key.	Did not connect through power supply. Main switch broken. Power supply wires problems. Control circuit fuse melt. Transformer broken.	Connect through power supply. Replace main switch. Check electrical wires. Fix the fuse. Replace the transformer.
Phase alarm.	Power supply low voltage. Phase shortage. Phase reversal. PCB problems.	Check power supply. Check power supply. Exchange two of the wires of power supply. Replace the PCB.
Pump overload.	Abnormal fluctuations of power supply. Pump blocked. Pump motor problems. Overload relay (F1) setting value error.	Check power supply. Check the pump. Check pump motor. Set the setting current of overload relay to equal to 1.1 times of motor rated current. Please refer to Mian Components for detailed description of overload relay. Reset overload relay: After waiting for about a few mins, wait for the pump to cool down and reset the overload information.
EGO overheat.	EGO temperature setting mistakes. EGO poor temperature detecting. Heater contactor K1 and K2 problems.	Correctly set EGO temperature. (EGO temperature setting value= temperature setting value+10℃) Replace EGO. Replace the contactor.
Low liquid level.	Oil shortage.0	Fill high temp. oil.
Temp. window displays "----"	Abnormal sensor.	Check and repair sensor.
Once running, pump output indicator lightens but pump cannot start. Afetr a while pump still fails to run.	PCB output relay problems. Electrical circuit problems.	Check or replace the PCB. Check electrical circuit.
Differences between setting temperature and actual temperature is too big.	Too short time after machine startup. Temperature parameter setting error. Cooling water valve problems.	Wait for a while. Check temperature parameters. Please refer to the standard manual of setting parameters. Replace solenoid valve.
Temperature can't rise up.	Heater contactor problems. Heater problems. Thermocouple problems. PCB output point problems.	Replace the contactor. Replace pipe heater. Replace thermocouple. Check and repair PCB.

Circuit breaker tripping off at turning on main switch.	Short circuit of main circuit. Transformer short circuit or connected with earth wire. Problems of circuit breaker.	Check electrical wire. Replace circuit breaker.
Circuit breaker tripping off at turning on pump switch.	Pump motor coil short circuit. Problems of circuit breaker.	Check pump motor. Replace circuit breaker.
Circuit breaker tripping off after short heater output.	Heater tube short circuit or shell contact. Problems of circuit breaker.	Replace heater tube. Replace circuit breaker.

6. Maintenance and Repair

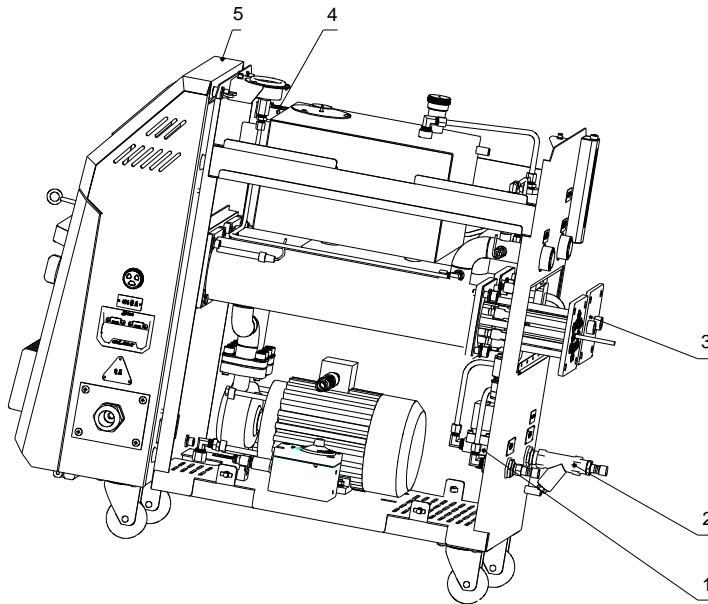

- 1) Clean the solenoid valve. Period: Every three months.
- 2) Clean the Y type filter. Period: Every month.
- 3) Clean the pipe heaters/cooling pipes. Period: Every six months.
- 4) Clean the liquid level switch. Period: Every three months.
- 5) Check the contactor. Period: Every three months.
- 6) High-temperature oil medium lifespan:
 - $\leq 120^{\circ}\text{C}$ Period: Replace each year.
 - $\geq 120^{\circ}\text{C} \sim \leq 60^{\circ}\text{C}$ Period: Replace every six months.
 - $> 160^{\circ}\text{C}$ Period: Replace every three months.

Pay attention to the following rules during maintenance:

- 1) Need at least two persons present when checking the machine. Let the machine cool down, turn off power supply, drain out the oil and water. Make sure enough place before checking and maintenance.
- 2) The machine works in high temperature. Stop the machine, wait it to cool down. Put on protective gloves before servicing or maintenance.
- 3) In order to prolong the life of the machine and to prevent accidents, check the machine at a fixed frequency.

- 4) During operation, the oil is heated up to a high temperature, wait it to fall below 50°C to perform repairing or maintenance.

(Please note that it is dangerous to check or tear down the machine during operation.)

6.1 Open the Covers

- 1) Lift the top cover gently to open it. (Refer to the pictures below)

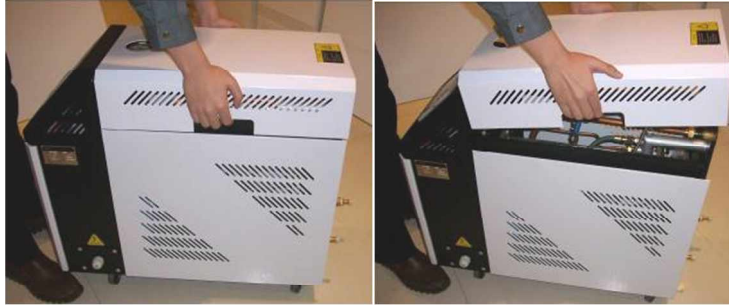

Picture 6-1: Open the Covers 1

- 2) Pull the bottom of side cover outward, and lift it to open. (Refer to the pictures below)

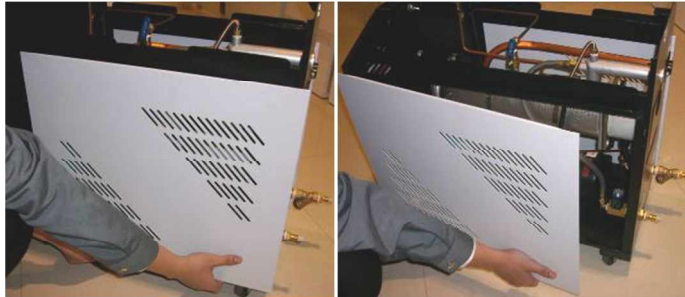

Picture 6-2: Open the Covers 2

- 3) Open the cover of control box. Screw off two butterfly screws to unlock the cover. (Refer to the pictures below)



Picture 6-3: Open the Covers 3

6.2 Y Type Strainer

- 1) Clean soft water should be used as cooling water. Y type strainer is used in the strainer to stop impurities and pollutants entering into water pipe.
- 2) Impurities or pollutants may cause errors and bad temperature control. Clean Y type strainer periodically.
- 3) Cleaning steps: turn off power and cooling water supply. Open the cover of Y type strainer to clean the strainer (as below picture).



Picture 6-4: Y Type Strainer

6.3 Solenoid Valve

Replace solenoid valve:

- 1) Open machine top cover (refer to 6.1)
- 2) Take down right side cover (refer to 6.1)
- 3) Unfix the solenoid valve for replacement.
- 4) Install the covers in a reverse order.



Solenoid valve

Picture 6-5: Solenoid Valve

6.4 Pipe Heater

- 1) Pull the black door locker downward, then draw it outward to open machine rear cover. (Refer to pictures below)



Picture 6-6: Pipe Heater 1

- 2) Unscrew the screws of heater cap and take it down. (Refer to pictures below)



Picture 6-7: Pipe Heater 2

- 3) Use the thinner or cloth dipped with thinner to clean the pipe heater. After the cleaning, put the pipe heater in the cool place for thinner total volatilization.
- 4) Install the pipe heater to the machine according to above opposite orders.

6.5 Cooling Pipes

After long use of the machine, as it is heated by high temperature, the heat transfer oil would carbonize and accumulate on machine pipeline. Too much of carbonization would lower the cooling efficiency of the cooling pipe. So it is needed to clean the carbon deposited on the cooling pipe. The cleaning steps are as below:

- 1) Pull the black door locker downward, then draw it outward to open machine rear cover. (Refer to pictures below)



Picture 6-8: Cooling Pipes 1

- 2) Screw off the screws of cooling pipe to take it out. (Refer to pictures below)



Picture 6-9: Cooling Pipes 2

- 3) Use the thinner or cloth dipped with thinner to clean the cooling pipe. After the cleaning, put the cooling pipe in the cool place for thinner total volatilization.
- 4) Install the cooling pipe to the machine according to above opposite orders.

Note:

Because the heat transfer oil may become carbonized agglutination after a long time heating, which will shorten the lifespan of the pump, so it is suggested to replace every three monthes.

Designated oil medium “shell Heat Transfer Oil S2”.

Flash point	210°C
Fire point	255°C
Initial boiling point	355°C
Signition point	360°C

Note: For failures caused by heat transfer oil of other brands, our after-sale service is not available.

6.6 Maintenance Schedule

6.6.1 About the Machine

Model _____ SN _____ Manufacture date _____

Voltage _____ Φ _____ V Frequency _____ Hz Power _____ kW

6.6.2 Installation & Inspection

- Check the installation space is enough as required.
- Check the pipes are correctly connected.

Electrical installation

- Voltage: _____ V _____ Hz
- Fuse melting current: 1 Phase _____ A 3 Phase _____ A
- Check phase sequence of power supply.

6.6.3 Daily Checking

- Check machine startup function.
- Check all the electrical wires.

6.6.4 Weekly Checking

- Check loose electrical connections.
- Check and clean Y type filter ¹.
- Check solenoid valve.
- Check motor overload and phase reversal alarm function.
- Check whether pipeline joints are under looseness.
- Check the sensitivity of EGO.

6.6.5 Trimonthly Checking

- Check level switch.

- Check the contactor ².
- Replace the hot kerosene with a using temperature above 160 degree ³.

6.6.6 Half-yearly Checking

- Check damaged pipes.
- Clean process heater/cooler.
- Check indicator and buzzer.
- Replace the hot kerosene with a using temperature above 120~160 degree ⁴.

6.6.7 Yearly Checking

- Replace the hot kerosene with a using temperature above 120 degree ⁵.

6.6.8 3 year Checking

- PC board renewal.
- No fuse breaker renewal.

- Note: 1. Y-type filter has the function of filling water cooling protection effect, be sure the waterway are clear to avoid cooling failure.
2. Manufacturer laboratory data for AC contactor is two million times in life. we suggest service life for one million four hundred thousand times, if work eight hours per day, recommended replacing frequency is 1.5 years, if work day and night, replacement is suggested to be done every six months.
3. Hot kerosene coke will influence the detection accuracy of internal temperature probe and the efficiency of heat elements, three months replacing frequency is suggested.
4. Hot kerosene coke will influence the detection accuracy of internal temperature probe and the efficiency of heat elements, six months replacing frequency is suggested.
5. Hot kerosene coke will influence the detection accuracy of internal temperature probe and the efficiency of heat elements, suggested replacing frequency is one year.

Appendix 1 :

SHINI Comm.Variable Table (1)

STM Comm. Variables					Comm. Protocol: MODBUS-RTU
D-Map(40 001+i)	English	Chinese	Range	Description	Type
1	CONTROL PV	Control temp.	-50 ~ 500	※1(Different displays depending on whether the temp. unit ° C has a decimal point.)	read only
2	RET PV	Return water temp.	-50 ~ 500		read only
3	ENT PV	Output water temp.	-50 ~ 500		read only
4	SV	Control target value	-50 ~ 500		read only
5	RTC YEAR	Current year	0 ~ 99	2000(0), 2001(1), ..., 2099(99)	read only
6	RTC MONTH	Current month	1 ~ 12		read only
7	RTC DATE	Current date	1 ~ 31		read only
8	RTC DAY	Current week	0 ~ 6	Sun.(0), Mon. (1), Tues.(2), ..., Sat.(6)	read only
9	RTC HOUR	Current hour	0 ~ 23		read only
10	RTC MINUTE	Current minute	0 ~ 59		read only
11	RTC SECOND	Current secs.	0 ~ 59		read only
12	CONTROL STATUS	Control status	0 ~ 3	Fault(0), stop control(1), In controlling(2), Auto-tuning(3)	read only
13	MMI STATUS	Running status	0 ~ 255	※2 (Operate it with bit address)(as shown in Appendix2)	read only
14	DO STATUS	Contact output status	0 ~ 255	※2 (Operate it with bit address)(as shown in Appendix2)	read only

15	DI STATU	Contact input status	0 ~ 255	※2 (Operate it with bit address)(as shown in Appendix2)	read only
16	ALARM STATUS	Alarm status	0 ~ 255	※2 (Operate it with bit address)(as shown in Appendix2)	read only
17	CONTROL PV ERROR	Control temp. input alarm	0 ~ 255	※2 (Operate it with bit address)(as shown in Appendix2)	read only
18	RET PV ERROR	Return water temp. input alarm	0 ~ 255	※2 (Operate it with bit address)(as shown in Appendix2)	read only
19	ENT PV ERROR	Water outlet temp. input alarm	0 ~ 255	※2 (Operate it with bit address)(as shown in Appendix2)	read only
20	REMOTE ERROR	Remote control input alarm	0 ~ 255	※2 (Operate it with bit address)(as shown in Appendix2)	read only
21	KEY STATUS	KEY key status	0 ~ 255	※2 (Operate it with bit address)(as shown in Appendix2)	read only
22	LED STATUS	LED indicator status	0 ~ 255	※2 (Operate it with bit address)(as shown in Appendix2)	read only
30		Switching value status	-	※3 As shown in Appendix3	read only
31		Relay status	-	※3 As shown in Appendix3	read only
32		Fault info. 1	-	※3 As shown in Appendix3	read only
33		Fault info.2	-	※3 As shown in Appendix3	read only
100	HOUT	Heating end output	0 ~ 100%		read only
101	COUT	Cooling end output	0 ~ 100%		read only
102		Backlight time	0 ~ 255	0 ~255	read /write

104	RUN/RESET KEY	RUN/RESET KEY	0, 1	1 = Key (button) operation. After this operation, it will be automatically reset to 0.	write only
105	AUTO-TUNING KEY	AUTO-TUNING KEY	0, 1		write only
106	AUTO-START KEY	AUTO-START KEY	0, 1		write only
107	SUCTION KEY	SUCTION KEY	0, 1		write only
108	COOLING KEY	COOLING KEY	0, 1		write only
109	BUZZER OFF KEY	BUZZER OFF KEY	0, 1		write only
110	SUCTION OFF KEY	SUCTION OFF KEY	0, 1		write only
112		Reset	1		write only
120		Flow value		Unit: 0.1L/min	read only
125		Pressure value		Unit:0.1bar	read only
150		Emptying temp.	0-120.0℃	When the PV temp. is less than [Emptying temp.], the reverse emptying can be started.	read /write
151		Emptying time	60 秒	0-600 secs.	read /write
200	SV	Control target value (℃)	-50 ~ 500℃	※1(Different displays depending on whether the temp. unit °C has a decimal point.)	read /write
201	PB	Heating control belt	0 ~ 550℃	※1(Different displays depending on whether the temp. unit °C has a decimal point.)	read /write
202	TI	Integral time	1 ~ 3600s		read /write
203	TD	Differential time	1 ~ 3600s		read /write
204	PBC	Cooling control zone	0 ~ 550℃	※1(Different displays depending on whether the temp. unit °C has a decimal	read /write

				point.)	
205	CT	Heating control cycle	1 ~ 100s		read /write
206	CTC	Cooling control cycle	1 ~ 100s		read /write
300	PHASE ALARM	Phase detection	0, 1	Unuse (0), use(1)	read /write
301	DEV1 ALARM	Output water temp. deviation	0 ~ 550°C	※1(Different displays depending on whether the temp. unit ° C has a decimal point.)	read /write
302	DEV2 ALARM	Return water temp. deviation	0 ~ 550°C		read /write
303	TURB ALARM	Interference alarm	0 ~ 550°C		read /write
304	HEATER ALARM	Heater alarm	0 ~ 3600s		read /write
401	SUB HEATING	Auxiliary output	0 ~ 550°C	※1(Different displays depending on whether the temp. unit ° C has a decimal point.)	read /write
402	COOLING TEMP	Cooling temp.	-50 ~ 500°C		read /write
500	H.LIMIT TEMP	Upper limit temp.	-50 ~ 500°C	※1(Different displays depending on whether the temp. unit ° C has a decimal point.)	read /write
501	L.LIMIT TEMP	Lower limit temp.	-50 ~ 500°C		read /write
502	TEMP UNIT	Temp. unit	0, 1	°C(0), °F(1)	read /write
503	TEMP DEGREE	Decimal point	0, 1	0.1(0), 1(1)	read /write
504	CTL TEMP BIAS	Control temp. correction	-550 ~ 550°C	※1(Different displays depending on whether the temp. unit ° C has a decimal point.)	read /write
505	RET TEMP BIAS	Return water temp. correction	-550 ~ 550°C		read /write

506	ENT TEMP BIAS	Output water temp. correction	-550 ~ 550℃		read /write
600	NOW YEAR	Year setting	0 ~ 99	2000(0), 2001(1), ..., 2099(99)	read /write
601	NOW MONTH	Month setting	1 ~ 12		read /write
602	NOW DATE	Date setting	1 ~ 31		read /write
603	NOW DAY	Week setting	0 ~ 6	Sun.(0), Mon. (1), Tues.(2), ..., Sat.(6)	read /write
604	NOW HOUR	Hour setting	0 ~ 23		read /write
605	NOW MINUTE	Minute setting	0 ~ 59		read /write
606	SCHEDULE DAY	Week reserve setting	0 ~ 127	Sun.(0), Mon. (1), Tues.(2), ..., Sat.(6)	read /write
607	AUTO-START HOUR	Reserve auto start hr. setting	0 ~ 24	Unuse (00:00)	read /write
608	AUTO-START MINUTE	Reserve auto start min. setting	0 ~ 59		read /write
609	AUTO-END HOUR	Reserve auto shutdown hr. setting	0 ~ 24	Unuse (00:00)	read /write
610	AUTO-END MINUTE	Reserve auto shutdown min. setting	0 ~ 59		read /write
611	AS SETTING TIME	Check time setting	0 ~ 9999	Unuse (00:00)	read /write
612	RUNNING TIME	Device using time	0 ~ 9999		read only
700	LANGUAGE	Language setting	0, 1	Chinese(0), English(1)	read /write
702	PASSWORD	Password setting	0 ~ 9999		read /write
703	RET/ENT DISP	Return water output temp.	0, 1	Unuse (0), use(1)	read /write
704	W-FILL TM T1	Water refilling	0 ~ 600s		read /write

		time T1			
705	W-FILL TM T2	Water refilling time T2	0 ~ 60s		read /write
706	RET/ENT DISP	Return loop display settings	0, 1, 2, 3	Display control loop, control+ return medium, control + mould, control+ return medium + mould	read /write

Appendix 2

SHINI Comm.Variable Table (2)

STM Comm. Variables					Comm. Protocol: MODBUS-RTU
D-Map(400 01+i.J)	Name	BIT			
		0	1	2	3
		4	5	6	7
13	MMI STATUS	Control	Cooling	Auto-tuning	Suction
		Reserve	Buzzer Off	--	Input power
14	DO STATUS	Pump forward action	Pump forward action	Water refilling	Suction
		Alarm	Breaker	Air	--
15	DI STATUS	Pump overload	EGO	Low pressure	High pressure
		Low liquid evel	High liquid evel	--	Start control
16	ALARM STATUS	Phase alarm	Temp. alarm	Deviation alarm	Interference alarm
		Heating alarm	--	--	--
17	CONTROL PV ERROR	--	-Over	+Over	Sensor Open
		AD Error-	--	--	--
18	RET PV ERROR	--	-Over	+Over	Sensor Open
		AD Error-	--	--	--
19	ENT PV ERROR	--	-Over	+Over	Sensor Open
		AD Error-	--	--	--
20	REMOTE ERROR	--	-Over	+Over	Input Open
		AD Error-	--	--	--
21	KEY STATUS	RUN	AUTO-TUNING	AUTO-START	SUCTION OFF

		COOLING	SUCTION	BUZZER OFF	Power
D-Map(400 01+i.J)	Name	BIT			
		0	1	2	3
		4	5	6	7
22	STATUS 1	RUN	AUTO-TUNING	SUCTION	COOLING
		BUZZER OFF	AUTO-START	SUCTION OFF	F
	STATUS 2	POWER	HEATER OUTPUT	AUXILIARY HEATING OUTPUT	COOLING OUTPUT
		PUMP FORWARD ACTION	PUMP REVERSE ACTION	WATER REFILLING	ALARM

MODBUS -RTU uses the RS485serial port.

Note: The address minimum value is 1. If it reads and writes from zero, an error will occur.