

# **HA**

## **Hot Air Dryer**

Date: Oct. 2017

Version: Ver.B (English)





## Contents

<b>1. General Description .....</b>	<b>5</b>
1.1 Coding Principle .....	6
1.2 Features .....	6
1.3 Accessory option .....	6
1.4 Technical Specifications .....	8
1.5 Safety Regulations .....	9
1.5.1 Safety Signs and Labels .....	9
1.6 Exemption Clause .....	10
<b>2. Structure Characteristics and Working Principle .....</b>	<b>11</b>
2.1 Function .....	11
2.1.1 Working Principle .....	11
2.2 Installation Diagram .....	12
2.2.1 Installed on the injection molding machine with heat preservation hopper. ....	12
<b>3. Maintenance and Repair .....</b>	<b>13</b>
3.1 Blower .....	13
3.2 Maintenance Schedule .....	14
3.2.1 General Machine Information .....	14
3.2.2 Installation & Inspection .....	14
3.2.3 Daily Checking .....	14
3.2.4 Weekly Checking .....	14
3.2.5 Monthly Checking .....	14
3.2.6 Half-yearly Checking .....	14

## Table Index

Table 1-1: Specifications .....	8
---------------------------------	---

## Picture Index

Picture 1-1: Outline Drawing .....	8
Picture 2-1: Working Principle .....	11
Picture 2-2: Installation on the Injection Molding Machine .....	12

# 1. General Description



Read this manual carefully before operation to prevent machine damage or personal injuries.

HA series which is with simple structure and in light weight is particularly suitable for working with heat-preservation hopper to dry engineering plastics. This series is capable of offering air volume within  $30\text{m}^3/\text{hr}\sim 700\text{m}^3/\text{hr}$ ; there are 8 models.

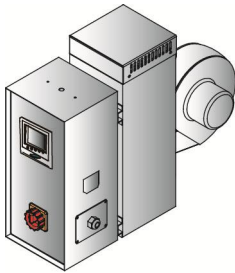

HA-30~400

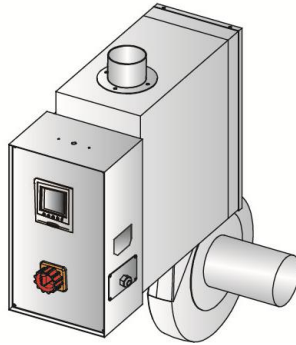

HA-600~700

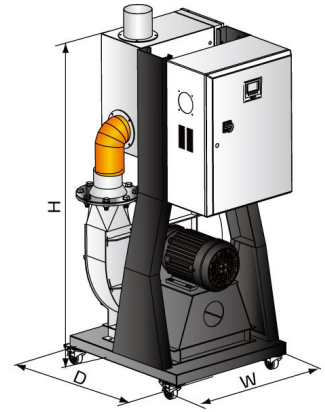

HA-1000 and above

## 1.1 Coding Principle

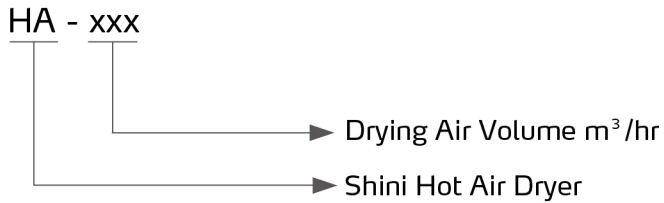

Notes: It's of CE conformity.

## 1.2 Features

- Microcomputer control helps to control temperature accurately.
- Using P.I.D. temperature controller, LCD status display, with RS485 communication
- With overheat protection, it can avoid accidents caused by man or machine failure.
- 7-day automatic start/stop timer helps to save power.

## 1.3 Accessory option

- Exhaust cyclone, exhaust air filter, hot air recycler and blower inlet filter are optional.
- Collocate with DH-U to constitute SHD-U dryer.

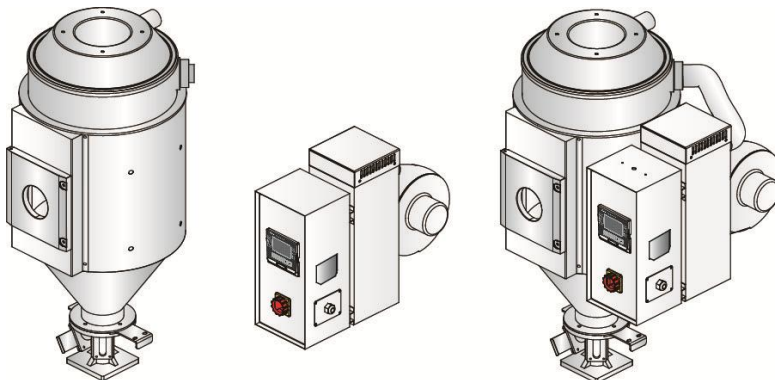

All service work should be carried out by a person with technical training or corresponding professional experience. The manual contains instructions for both handling and servicing. Chapter 6, which contains service instructions intended for service engineers. Other chapters contain instructions for operators.

Any modifications of the machine must be approved by SHINI in order to avoid personal injury and damage to machine. We shall not be liable for any damage caused by unauthorized change of the machine.

Our company provides excellent after-sales service. Should you have any problem during using the machine, please contact the company or the local vendor.

Headquarter and Taipei factory:

Tel: (886) 2 2680 9119

Shini Plastics Technologies (Dongguan), Inc:

Tel: (86) 769 8111 6600

Shini Plastics Technologies India Pvt.Ltd. :

Tel: (91) 250 3021 166

## 1.4 Technical Specifications

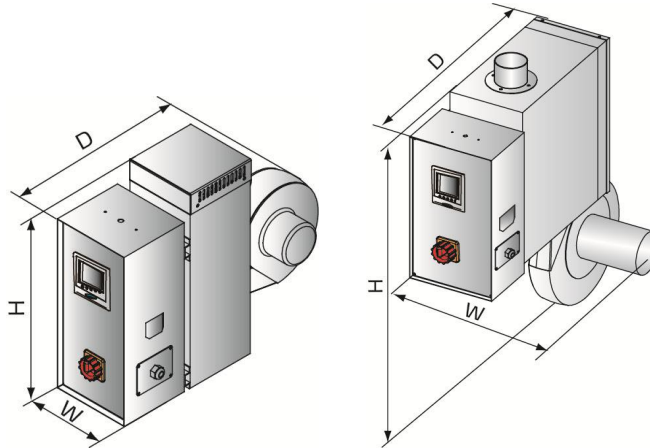

Picture 1-1: Outline Drawing

Table 1-1: Specifications

Model	Drying Air Volume (m <sup>3</sup> /hr)	Drying Heater (kW)	Blower (kW)	Dimensions H×W×D (mm)	Air Outlet Pipe Dia. (inch)
HA-30	30	2.2	0.05	437×558×284	2"
HA-40	40	3	0.12	437×608×334	2"
HA-60	60	3.9	0.12	505×669×334	2.5"
HA-100	100	6	0.12	613×725×347	3"
HA-200	200	12	0.18	755×817×363	3"
HA-400	400	18	0.55	645×975×442	4"
HA-600	600	24	0.55	1030×1110×410	4"
HA-700	700	24	1.1	1090×1190×430	4"

Power supply: 3Φ, 230 / 400 / 460 / 570V, 50 / 60Hz.

We reserve the right to change specifications without prior notice.



## 1.5 Safety Regulations



### Note!

Electrical installation should be done by qualified electrician.

Before connecting to power source, make sure that specifications and overload protection rating of the power switch are suitable and reliable; what's more, turn power switch to OFF position. When maintaining, turn off both power switch and automatic operation switch.

### 1.5.1 Safety Signs and Labels



### Danger!

High Voltage!

It is attached to the control box.



### Attention!

This mark reminds you to be more careful.



### Warning!

High temperature surface may burn hands!

This label should be stick to the shell of electric heating box.



### Attention!

All screws for installing the electrical components inside the control box are locked tight. There is no need to check on them regularly.



### Attention!

The EGO protection value has been set before delivery. Please don't adjust it.



### Attention!

When starting up, all hot air pipes of all models should be connected well to avoid damage of the blower.



Attention!

When starting up, adjust the air-in valve of the blower to half-open state to prevent it from damage.

## 1.6 Exemption Clause

The following statements clarify the responsibilities and regulations born by any buyer or user who purchases products and accessories from Shini (including employees and agents).

Shini is exempted from liability for any costs, fees, claims and losses caused by reasons below:

1. Any careless or man-made installations, operation and maintenances upon machines without referring to the Manual prior to machine using.
2. Any incidents beyond human reasonable controls, which include man-made vicious or deliberate damages or abnormal power, and machine faults caused by irresistible natural disasters including fire, flood, storm and earthquake.
3. Any operational actions that are not authorized by Shini upon machine, including adding or replacing accessories, dismantling, delivering or repairing.
4. Employing consumables or oil media that are not appointed by Shini.

## 2. Structure Characteristics and Working Principle

### 2.1 Function

HA hot air dryer offers constant high temperature air to material tank by blower.

#### 2.1.1 Working Principle

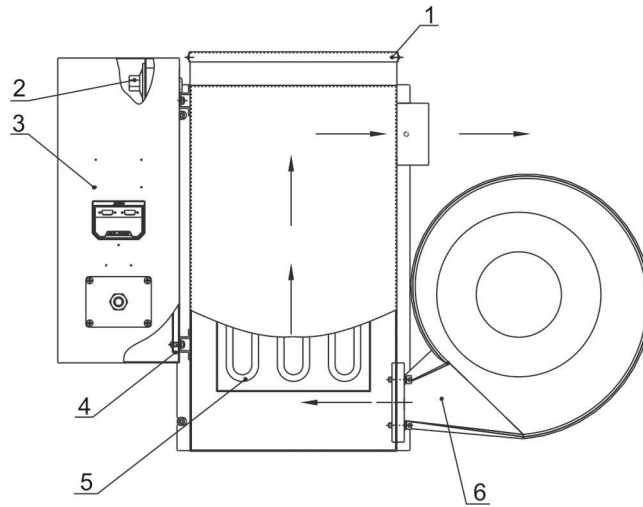

Names of Parts:

- |                             |                                    |                |
|-----------------------------|------------------------------------|----------------|
| 1. Heating box cover        | 2. Over temperature protection EGO | 3. Control box |
| 4. Heating box fixing plate | 5. Pipe heater                     | 6. Blower      |

Picture 2-1: Working Principle

## 2.2 Installation Diagram

### 2.2.1 Installed on the injection molding machine with heat preservation hopper.

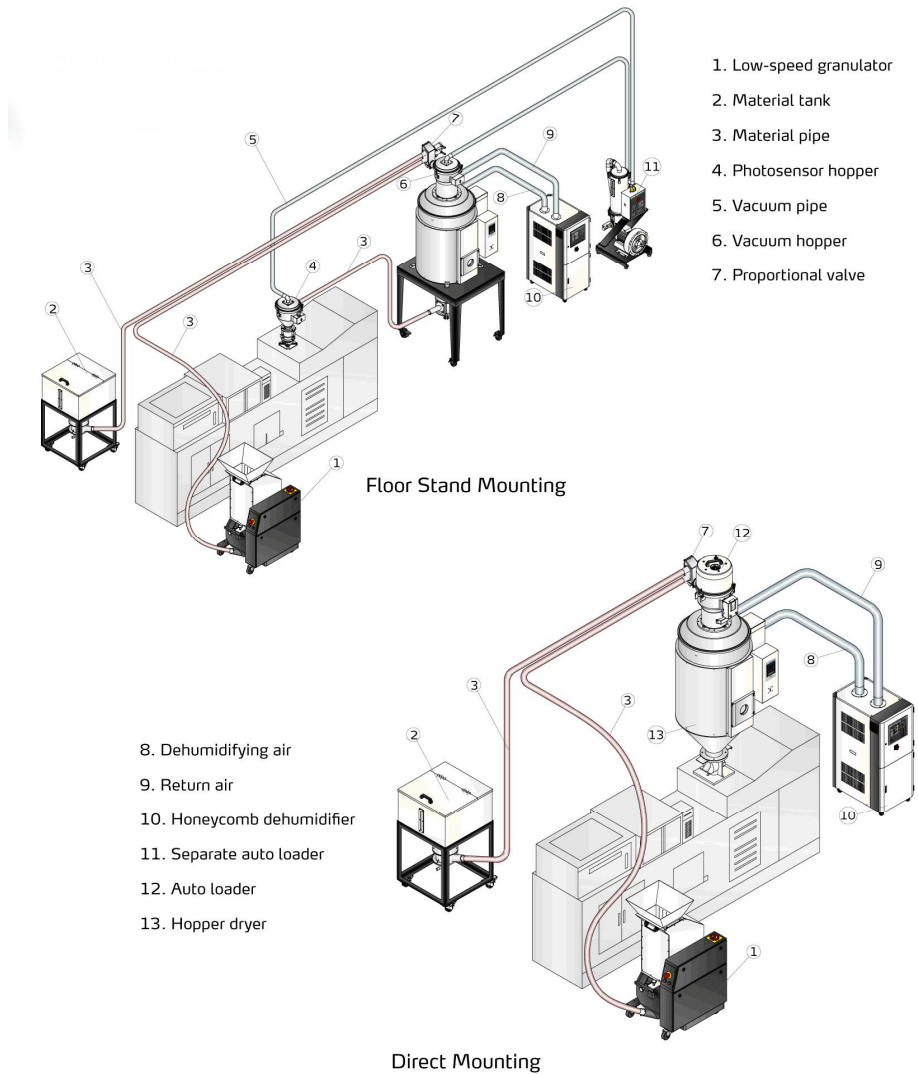

Picture 2-2: Installation on the Injection Molding Machine

### 3. Maintenance and Repair

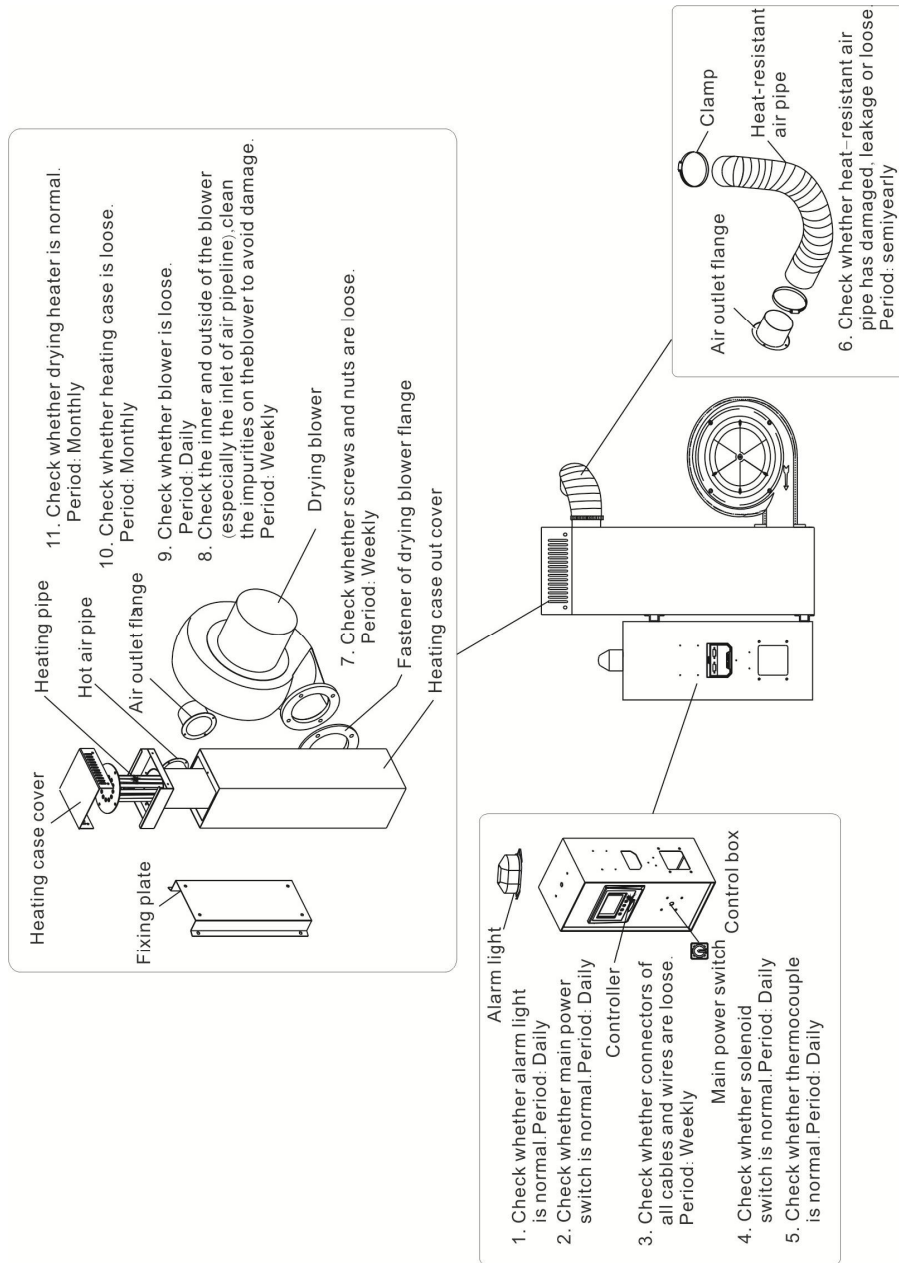

#### 3.1 Blower

- 1) Clean the inner and outer parts (especially the air pipes at air inlet) of the blower regularly to remove dust on surface.
- 2) Remove foreign material on leaves of the blower to prevent it from damage.

## 3.2 Maintenance Schedule

### 3.2.1 General Machine Information

Model \_\_\_\_\_ SN \_\_\_\_\_ Manufacture date \_\_\_\_\_

Voltage \_\_\_\_\_  $\Phi$  \_\_\_\_\_ V Frequency \_\_\_\_\_ Hz Power \_\_\_\_\_ kW

### 3.2.2 Installation & Inspection

- Check if the connecting pipe is tightly locked or not.
- Check that the piping system is correctly connected.

#### Electrical Installation

- Voltage: \_\_\_\_\_ V \_\_\_\_\_ Hz
- Fuse melt current: 1 Phase \_\_\_\_\_ A 3 Phase \_\_\_\_\_ A
- Check phase sequence of the power supply.
- Check the rotating direction of the blower.

### 3.2.3 Daily Checking

- Check the switches of the machine.
- Check the auto-start function of the machine.

### 3.2.4 Weekly Checking

- Check all the electrical cables of the machine.
- Check if there are loose electrical connections.
- Check whether overheat protection is normal.

### 3.2.5 Monthly Checking

- Check if the pipe heater is working properly.
- Check the performance of blower.
- Check the performances of electrical components.

### 3.2.6 Half-yearly Checking

- Check if there are damages with heat-resistant pipe or not.
- Check the drying heater.
- Check the blower.