

机型版本 Ver.E				制图		版号 J		标题 SG-3650		图号 SG-3650-CE-230V-J-1		比例		第 1 张	
				设计		核准		主电路图				标准 CE		共 9 张	
				校对		日期 20220727		 信易电热机械股份有限公司 Shini Plastics Technologies, Inc.		机器电压		3φ230V			
标记		更改前		更改后		更改人				日期		机器频率		50Hz	

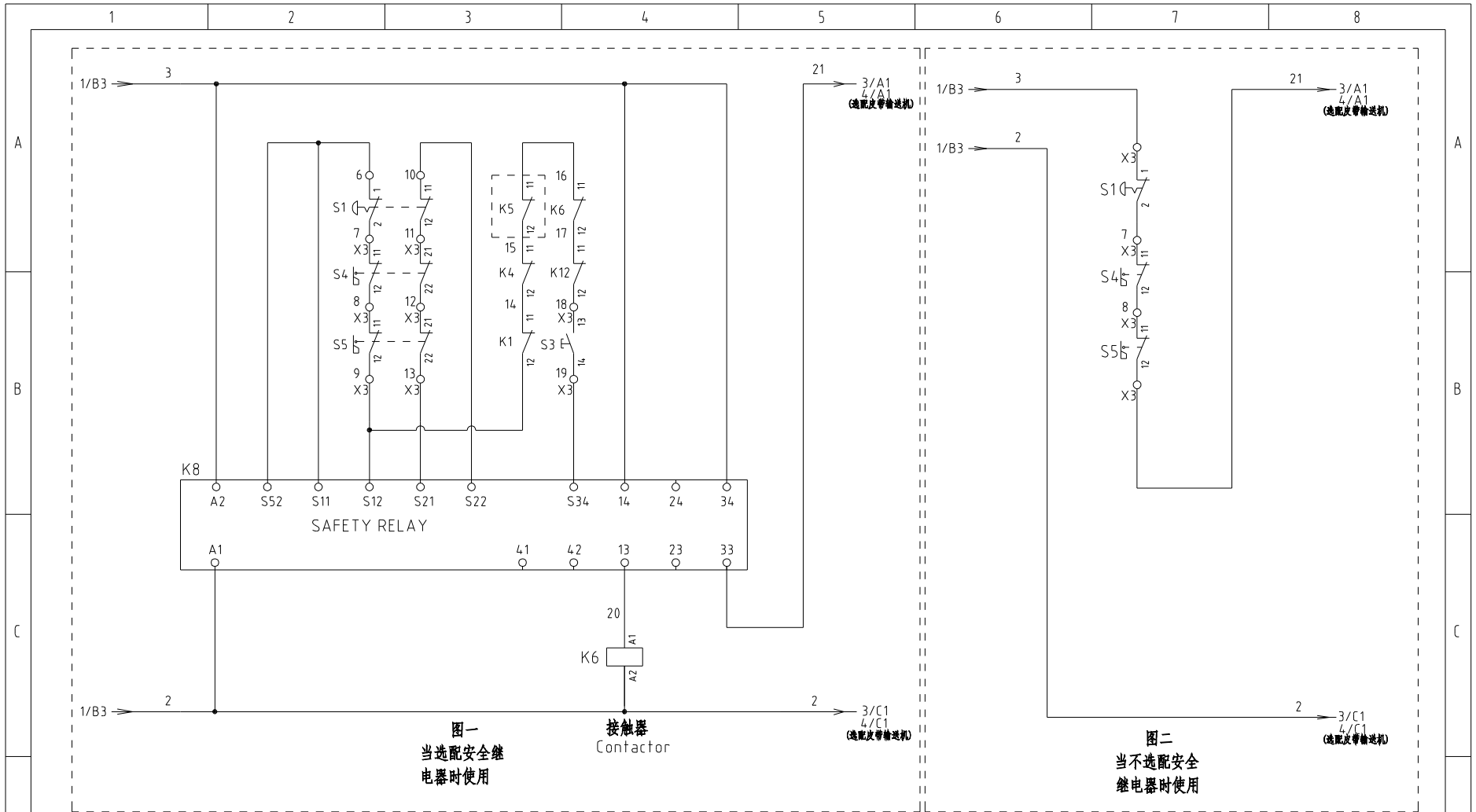

机型版本 Ver.E				制图		版号 J		标题 SG-3650		图号 SG-3650-CE-230V-J-2		比例		第 2 张	
				设计		核准		控制电路图一				标准 CE		共 9 张	
				校对		核准		 信易電熱機械股份有限公司 Shini Plastics Technologies, Inc.		机器电压		3φ230V			
标记		更改前		更改后		更改人				日期		20220727		机器频率	
1	2	3	4	5	6	7	8								

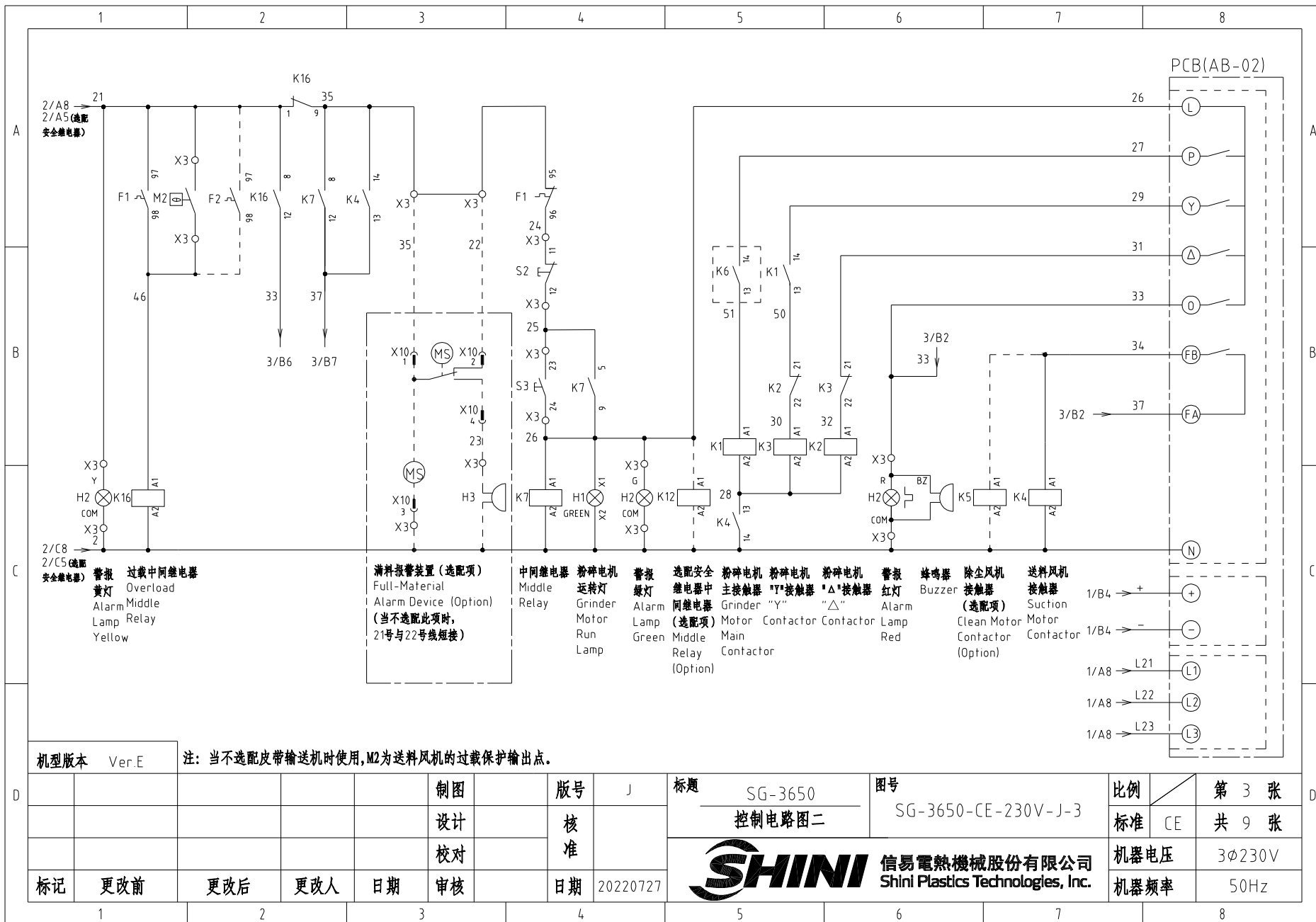

机型版本 Ver.E

注: 当不选配皮带输送机时使用, M2为送料风机的过载保护输出点。

制图	版号	J
设计	核准	
校对	核准	
标记	更改前	更改后
	更改人	日期
审核	日期	20220727

标题 SG-3650
控制电路图二

图号 SG-3650-CE-230V-J-3

比例 第 3 张
标准 CE 共 9 张

SHINI 信易电热机械股份有限公司
Shini Plastics Technologies, Inc.

机器电压 3φ230V
机器频率 50Hz

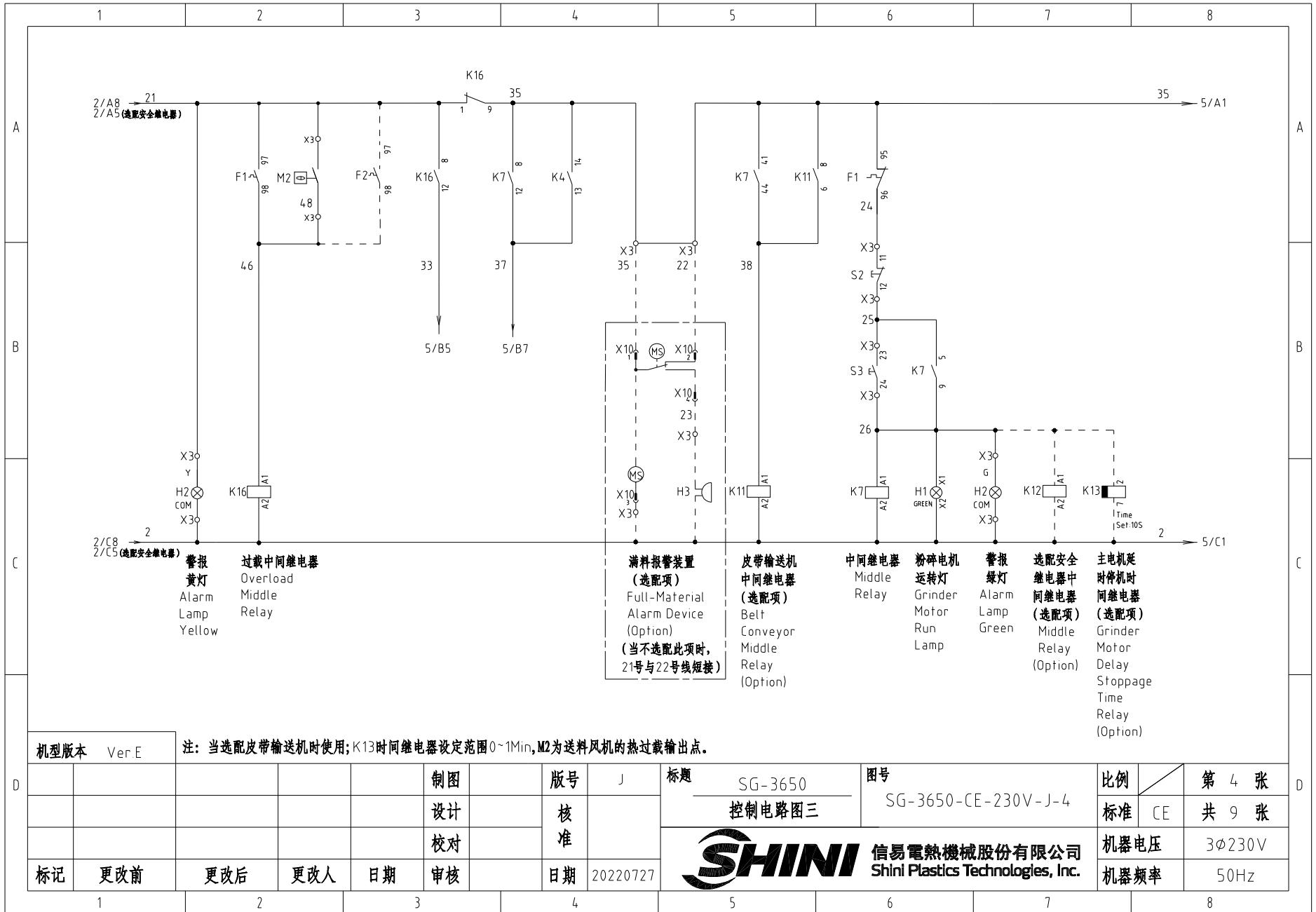

警报
黄灯
Alarm
Lamp
Yellow

过载中间继电器
Overload
Middle
Relay

满料报警装置
(选配项)
Full-Material
Alarm Device
(Option)
(当不选配此项时,
21号与22号线短接)

皮带输送机
中间继电器
(选配项)
Belt
Conveyor
Middle
Relay
(Option)

中间继电器
Middle
Relay

粉碎电机
运转灯
Grinder
Motor
Run
Lamp

警报
绿灯
Alarm
Lamp
Green

选配安全
继电器中
间继电器
(选配项)
Middle
Relay
(Option)

主电机延
时停机时
间继电器
(选配项)
Grinder
Motor
Delay
Stoppage
Time
Relay
(Option)

机型版本 Ver E

注: 当选配皮带输送机时使用; K13时间继电器设定范围0~1Min, M2为送料风机的热过载输出点。

制图	版号	J
设计	核准	
校对	核准	
标记	更改前	更改后
更改人	日期	20220727

标题 SG-3650
控制电路图三

图号 SG-3650-CE-230V-J-4

比例 第 4 张
标准 CE 共 9 张



信易电热机械股份有限公司
Shini Plastics Technologies, Inc.

机器电压 3φ230V
机器频率 50Hz

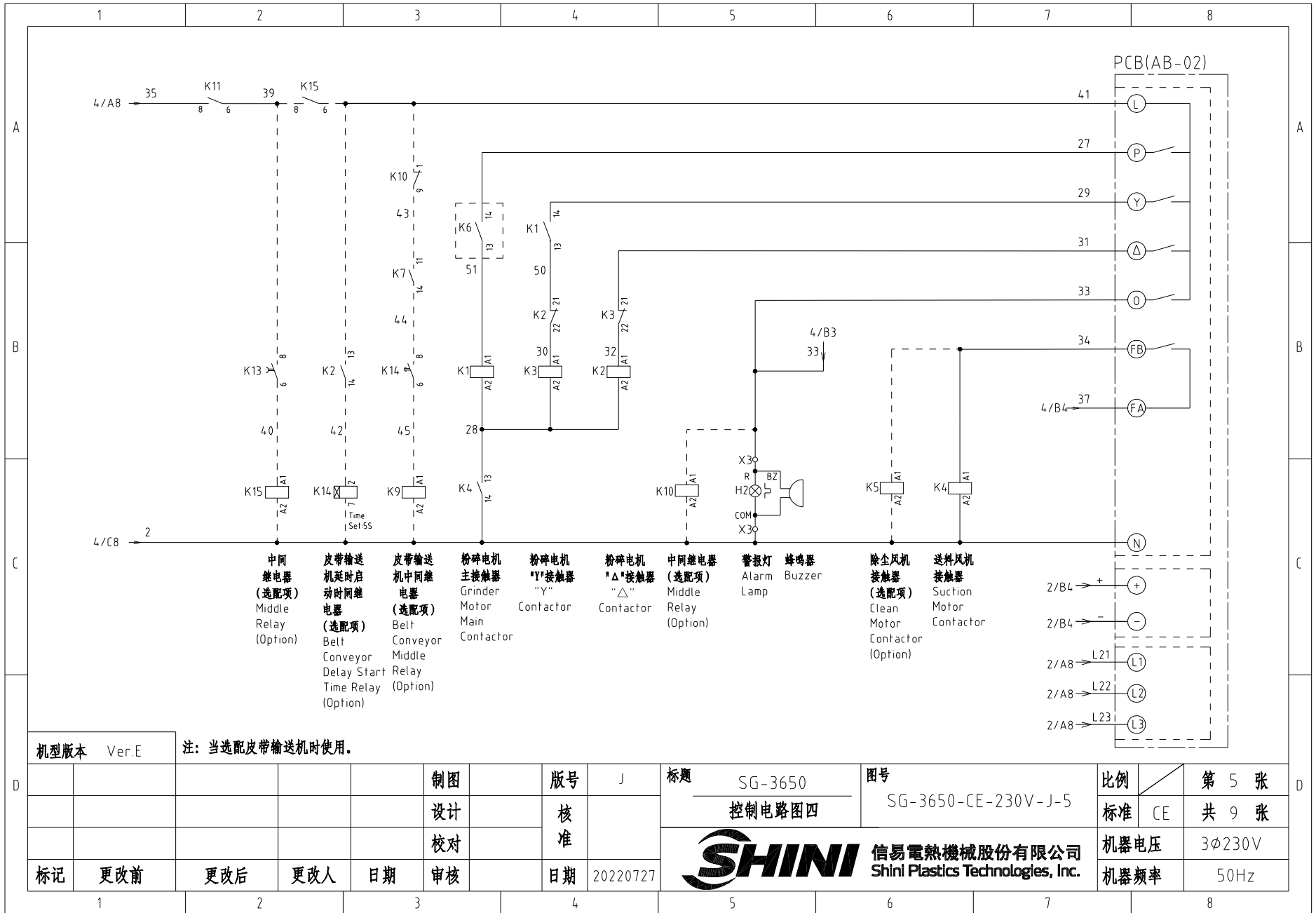

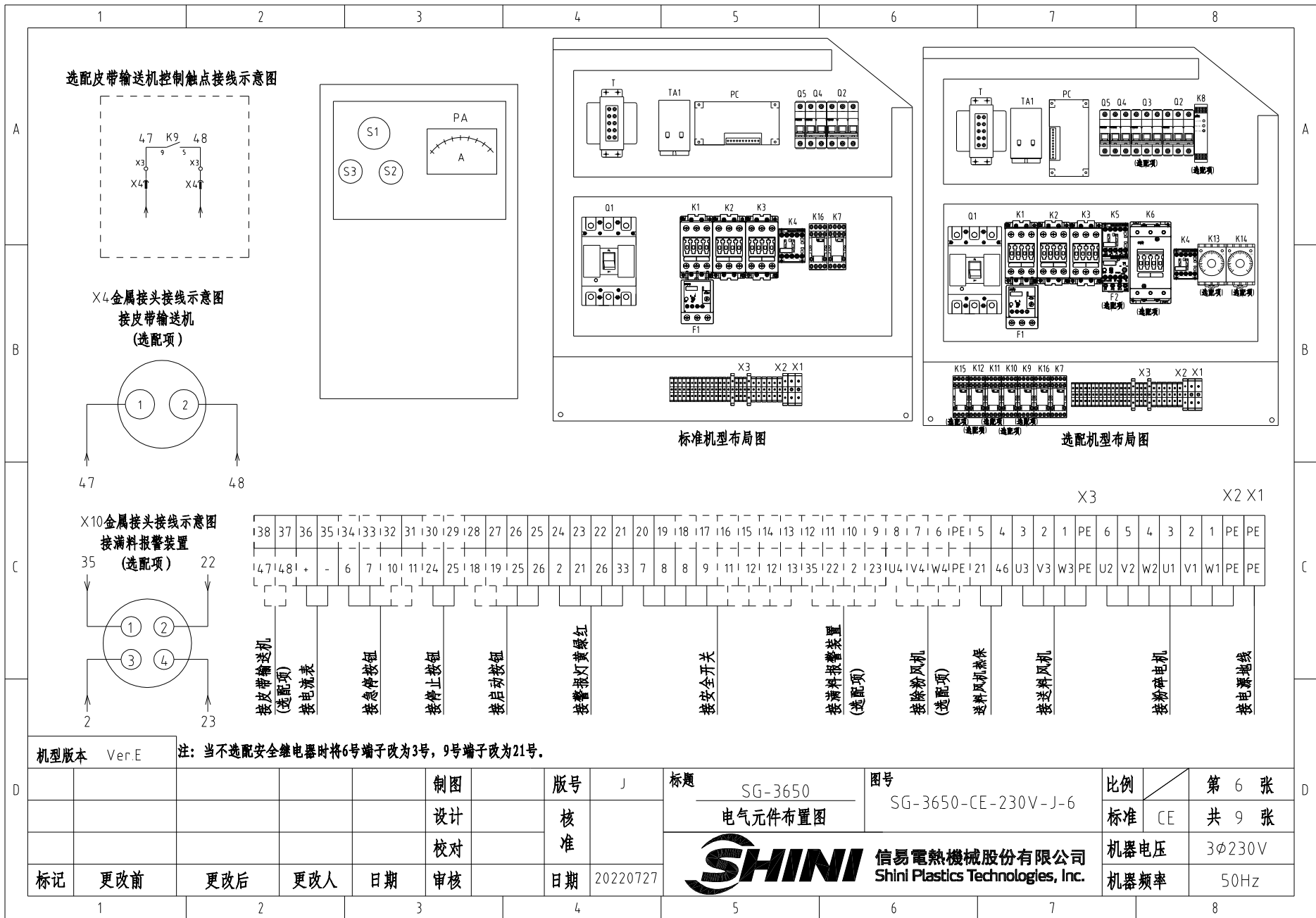

1		2		3		4		5		6		7		8	
序号/NO	符号/Symbol	名称/Name	制造商/Manufacturer	型号/Type	规格/Specification	数量/Number	物料编号/Material number	备注/Remark							
A	1	Q1	门连锁断路器/Gate circuit breaker	TECO	TAX-125L3125 3P	125A	1	YE40125301100							
	2		断路器外部操作把手/External operating handle	TECO	FB1R-CS1-C-D1x(TAX-125)	----	1	YE90111100300							
	3	Q2	断路器/Circuit breaker	TECO	BM-63C	10A	1	YE40301003000	(6)						
	4	Q2	断路器/Circuit breaker	TECO	BM-63C	16A	1	YE40301603000	(7)						
	5	Q3	断路器/Circuit breaker	TECO	BM-63C	10A	1	YE40301003000	(2)						
	6	Q4	断路器/Circuit breaker	TECO	BM-63C/2003S 2P	3A	1	YE40200203000							
	7	Q5	断路器/Circuit breaker	TECO	BM-63C/1010S 1P	10A	1	YE40101000100							
B	8	K1	接触器/Contactor	SIEMENS	3RT5036-1AC20	50A 24VAC 50/60Hz	1	YE00503602600							
	9		辅助触点/Auxiliary Contactor	SIEMENS	3RH5921-1CA01	1NC	1	YE00592110100	(4)						
	10		辅助触点/Subsidiary Contactor	SIEMENS	3RH5921-1CA10	1NO	1	YE00592110000							
	11	K2	接触器/Contactor	SIEMENS	3RT5036-1AC20	50A 24VAC 50/60Hz	1	YE00503602600							
	12		辅助触点/Auxiliary Contactor	SIEMENS	3RH5921-1CA01	1NC	1	YE00592110100							
	13		辅助触点/Auxiliary Contactor	SIEMENS	3RH5921-1CA10	1NO	1	YE00592110000	(5)						
	14	K3	接触器/Contactor	SIEMENS	3RT5035-1AC20	40A 24VAC 50/60Hz	1	YE00503502600							
C	15		辅助触点/Auxiliary Contactor	SIEMENS	3RH5921-1CA01	1NC	1	YE00592110100							
	16	K4	接触器/Contactor	SIEMENS	3RT6016-1AB01	9A 24VAC 50/60Hz	1	YE00601602500	(6)						
	17	K4	接触器/Contactor	SIEMENS	3RT6016-1AB01	9A 24VAC 50/60Hz	1	YE00601602500	(7)						
	18		辅助触点/Auxiliary Contactor	SIEMENS	3RH6911-1HA11	1NC+1NO	1	YE00691100100							
	19	K5	接触器/Contactor	SIEMENS	3RT6016-1AB02	9A 24VAC 50/60Hz	1	YE00601602600	(2)						
	20	K6	接触器/Contactor	SIEMENS	3RT5045-1AC20	80A 24VAC 50/60Hz	1	YE00504502600	(4)						
	21		辅助触点/Auxiliary Contactor	SIEMENS	3RH5921-1CA01	1NC	1	YE00592110100	(4)						
	22		辅助触点/Subsidiary Contactor	SIEMENS	3RH5921-1CA10	1NO	1	YE00592110000	(4)						
D	23	K7	中间继电器/Middle relay	Honeywell	GR-2C-AC24V	24VAC	1	YE03022400300							
	24	K7	中间继电器/Middle relay	Honeywell	GR-4C-AC24V	24VAC	1	YE03042400300	(5)						
	25	K8	安全继电器/Safety relay	PILZ	PN0Zx2.8P	24V AC/DC	1	YE04023000000	(4)						
机型版本 Ver.E		注: (1)表示非电控箱内材料; (2)表示除尘马达选配件; (3)表示满料报警装置选配件; (4)表示安全继电器选配件; (5)表示皮带输送机选配件; (6)表示选用标准风机选项; (7)表示增大送料风机功率选项。													
D					制图	版号	J	标题	SG-3650	图号	比例		第 7 张		
					设计	核 准	电气元件明细表一		SG-3650-CE-230V-J-7		标准	CE	共 9 张		
					校对		 信易电热机械股份有限公司 Shini Plastics Technologies, Inc.		机器电压		3φ230V				
	标记	更改前	更改后	更改人	日期	审核			日期	20220727	机器频率		50Hz		
1		2		3		4		5		6		7		8	

1		2		3		4		5		6		7		8		
序号/NO	符号/Symbol	名称/Name		制造商/Manufacturer		型号/Type		规格/Specification		数量/Number	物料编号/Material number		备注/Remark			
A	26	T	互感变压器/Transformer		----		IN=230V/200V OUT=24V		230VA	1	YE70023006100		选配(4)时去掉			
	27	T	互感变压器/Transformer		----		IN=230/200V OUT=24VAC		300VA	1	YE70023005000		(4)			
	28	K9 K10 K11 K15	中间继电器/Middle relay		Honeywell		GR-2C-AC24V		24VAC	4	YE03022400300		(5)			
	29	K12	中间继电器/Middle relay		Honeywell		GR-2C-AC24V		24VAC	1	YE03022400300		(4)			
	30	K13	定时器/Timer		YUYUN		TRF-N/3M		24VAC	1	YE86032400000		(5)			
	31	K14	定时器/Timer		YUYUN		TH3A-NAB 60S		24VAC	1	YE86602400300		(5)			
	32	F2	热过载继电器/Overload relay		SIEMENS		3RU1116-1EB0		2.8-4A	1	YE01160280000		(2)			
B	33	F1	热过载继电器/Overload relay		SIEMENS		3RU6126-4FB0		34-40A	1	YE01612640000					
	34	K16	中间继电器/Middle relay		Honeywell		GR-2C-AC24V		24VAC	1	YE03022400300					
	35	X1	端子排/Terminal		HoneyWell		GK35PE		35mm ² PE	1	YE60003503500					
	36	X2	端子排/Terminal		HoneyWell		GK10		10mm ²	6	YE60001003200					
	37				HoneyWell		GK10PE		10mm ² PE	1	YE60001003500					
	38	X3	端子排/Terminal		HoneyWell		SK2.5		2.5mm ²	21	YE60002503200					
	39				HoneyWell		GK2.5PE		2.5mm ² PE	1	YE60002503400					
	40				HoneyWell		SK2.5		2.5mm ²	3	YE60002503200		(2)			
C	41				HoneyWell		GK2.5PE		2.5mm ² PE	1	YE60002503400		(2)			
	42				HoneyWell		SK2.5		2.5mm ²	4	YE60002503200		(3)			
	43				HoneyWell		SK2.5		2.5mm ²	8	YE60002503200		(4)			
	44				HoneyWell		SK2.5		2.5mm ²	2	YE60002503200		(5)			
	45	X4	金属接头/Metal tie in		SHINI		PLT-162-RR(公)		2P	1	YE68016200100		(1)(5)			
	46	X10	金属接头/Metal tie in		SHINI		PLT-254PM		4P	1	YE68025400000		(1)(3)			
	47				SHINI		PLT-254RF		4P	1	YE68025400100		(1)(3)			
	48	S1	急停按钮/Emergency stop button		SCHNEIDER		XB2BS542C		400VAC	1	YE11254200000		(1)			
D	49		触点块/Contact block		SCHNEIDER		ZB2BE102C		1NC	1	YE00210203100		(1)(4)			
	50	S2	停止按钮/Stop button		SCHNEIDER		XB2BA22C		400VAC	1	YE11222000000		(1)			
	机型版本 Ver E		注: (1)表示非电控箱内材料; (2)表示除尘马达选配件; (3)表示满料报警装置选配件; (4)表示安全继电器选配件; (5)表示皮带输送机选配件; (6)表示选用标准风机选项; (7)表示增大送料风机功率选项。													
D					制图		版号 J		标题 SG-3650		图号 SG-3650-CE-230V-J-8		比例		第 8 张	
					设计		核		电气元件明细表二				标准 CE		共 9 张	
					校对		准		 信易電熱機械股份有限公司 Shini Plastics Technologies, Inc.		机器电压		3φ230V			
	标记		更改前		更改后		更改人				日期		20220727		机器频率	
1		2		3		4		5		6		7		8		

1		2		3		4		5		6		7		8	
序号/NO	符号/Symbol	名称/Name		制造商/Manufacturer		型号/Type		规格/Specification		数量/Number	物料编号/Material number		备注/Remark		
A	51	S3,H1	启动按钮(带灯) /Start button		SCHNEIDER		XB2BW33B1C		24 VAC		1	YE11233100000		(1)	
	52		触点块/Contact block		SCHNEIDER		ZB2BE101C		1NO		1	YE00210103100		(1)(4)	
	53	S4,S5	安全开关/Safety switch		SCHMERSRC		AZ15-02ZVRK-1476		AZ-15		2	YE16147600100		(1)	
	54	S4,S5	安全开关/Safety switch		SCHMERSRC		AZ16-02ZVRK-1476		AZ-16		2	YE16147600000		(1)(4)	
	55	H2	三色警报灯/Alarm lamp		SHINI		红绿黄优先顺序+蜂鸣器		24 VAC		1	BL90002401520		(1)	
	56	H3	蜂鸣器/Buzzer		TEND		EA-2		24 VAC		1	YE84240200000		(1)(3)	
	57	MS	料位开关/Feed position motor		SIPAI		SR-80		24 VAC		1	YE15802400100		(1)(3)	
B	58	PA	电流表/Galvanometry		SFIM		DH-670		100/5A		1	YE25671000000		(1)	
	59	TA1	电流互感器/Current mutual inductance		RATIO		RCT-35		100/5A		1	YE04100500000			
	60	TA2	电流互感器/Current mutual inductance		YUYUN		-----		5-100A		1	-----		线路板自带	
	61	PCB	微电脑板/PCB		YUYUN		AB-02		24 VAC		1	YE80022400100			
	62	M1	粉碎电机/Granulating motor		SIEMENS		18.5KW		230V 50HZ		1	-----		(1)	
	63	M2	吸料风机/Solution blower		SHINI		1.1KW		230V 50HZ		1	-----		(1)(6)	
	64	M2	吸料风机/Solution blower		SHINI		1.5KW		230V 50HZ		1	-----		(1)(7)	
C	65	M3	除尘风机/Dust blower		SHINI		0.75KW		230V 50HZ		1	-----		(1)(2)	
			终端固定件E/GK		HONEYWELL		-----		-----		4	YE60000003900			
D	机型版本 Ver E		注: (1)表示非电控箱内材料; (2)表示除尘马达选配件; (3)表示满料报警装置选配件; (4)表示安全继电器选配件; (5)表示皮带输送机选配件; (6)表示选用标准风机选项; (7)表示增大送料风机功率选项。												
					制图		版号	J	标题	SG-3650	图号	SG-3650-CE-230V-J-9		比例	第 9 张
					设计		核准		电气元件明细表三			标准	CE	共 9 张	
					校对		核准				信易電熱機械股份有限公司 Shini Plastics Technologies, Inc.		机器电压	3φ230V	
标记	更改前	更改后	更改人	日期	审核		日期	20220727					机器频率	50Hz	
1	2	3	4	5	6	7	8								

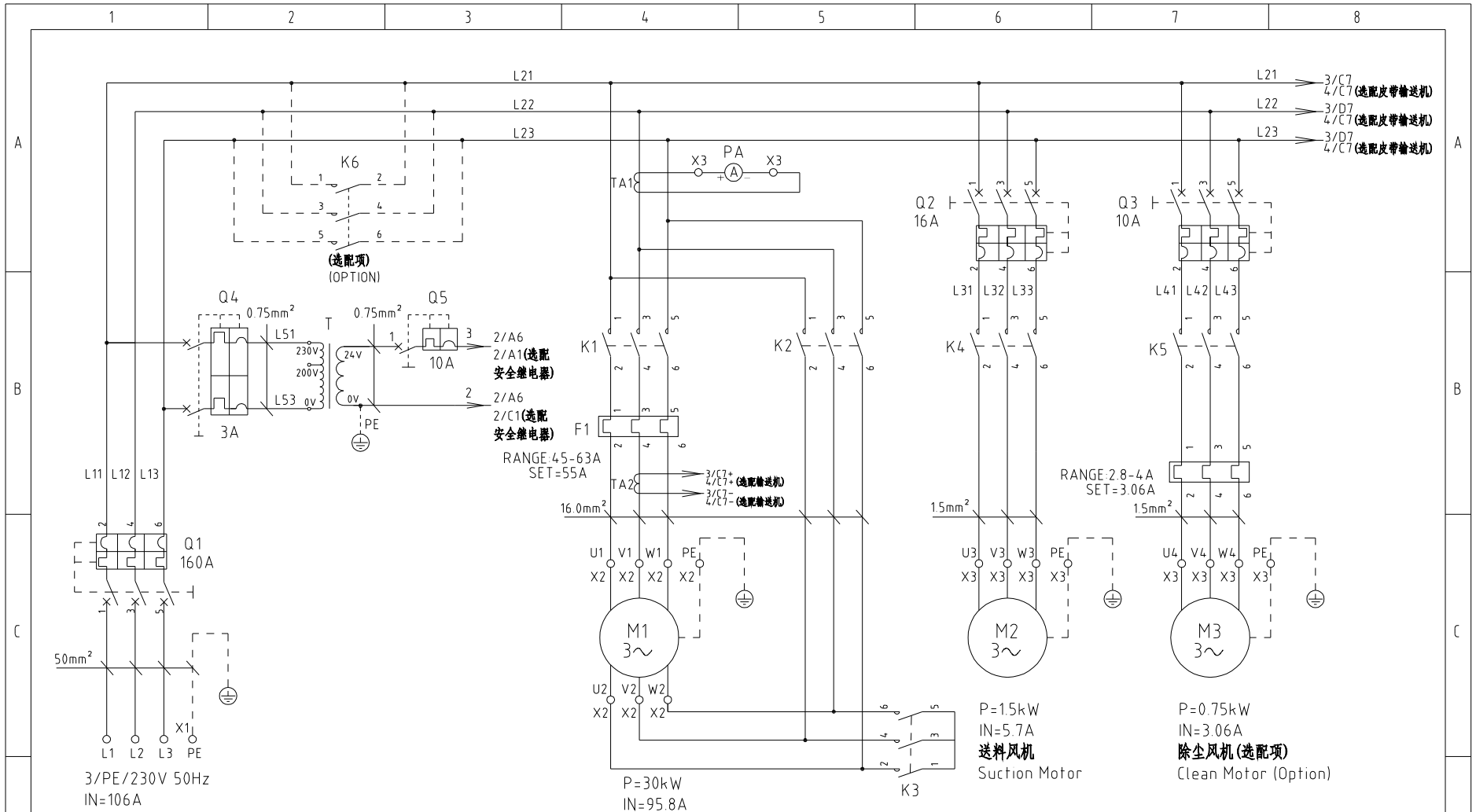

注：当选配增大送料风机时使用Q2=16A, P=2.2KW, IN=8.1A。

机型版本 Ver.E				制图		版号 J		标题 SG-3675		图号 SG-3675-CE-230V-J-1		比例		第 1 张	
				设计		核准		主电路图				标准 CE		共 9 张	
				校对		日期 20220727		SHINI 信易电热机械股份有限公司 Shini Plastics Technologies, Inc.		机器电压		3φ230V			
标记		更改前		更改后		更改人		日期		机器频率		50Hz			

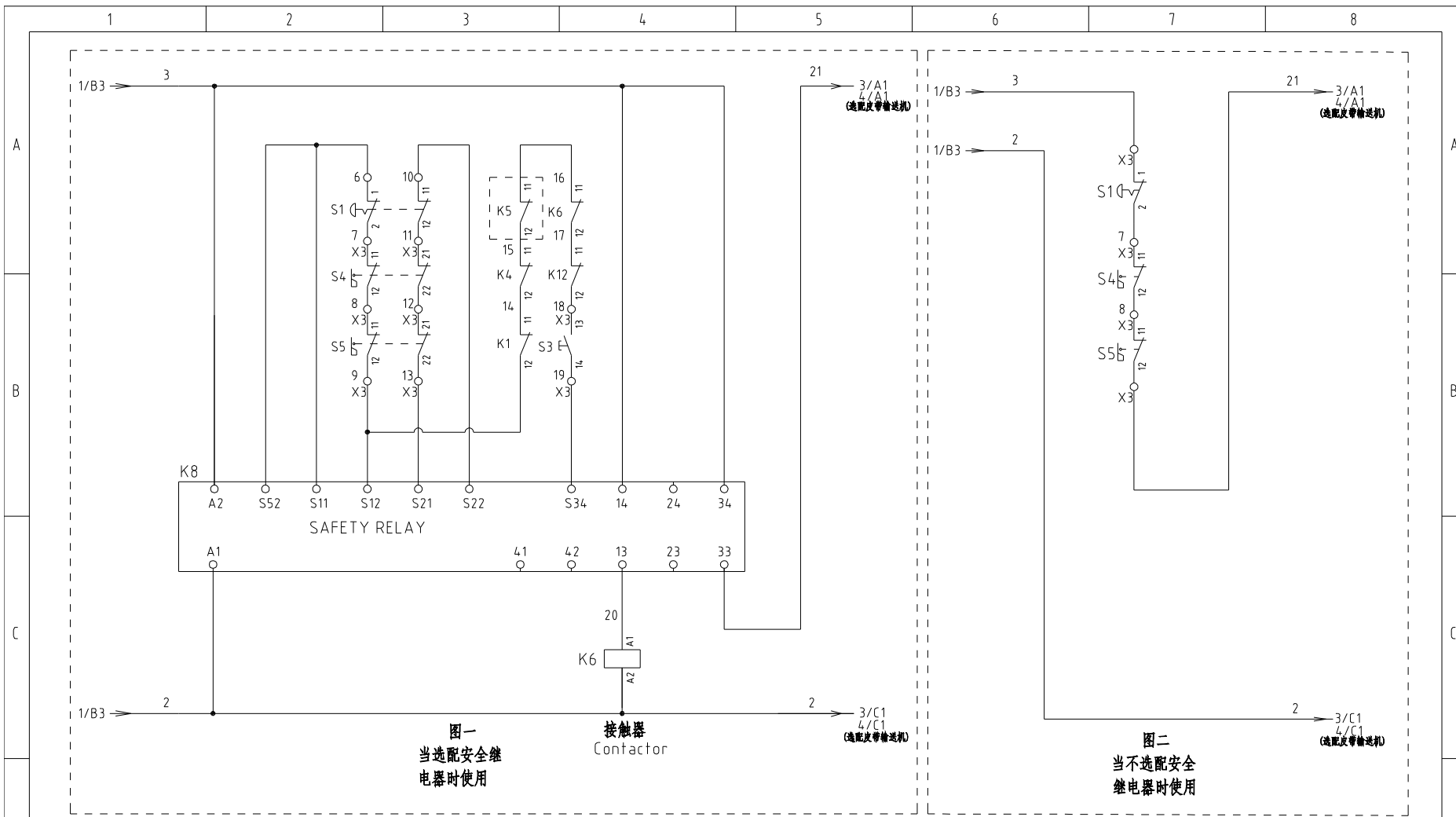

图一
当选配安全继电器使用时

接触器
Contactor

图二
当不选配安全继电器使用时

机型版本 Ver.E				制图		版号 J		标题 SG-3675		图号 SG-3675-CE-230V-J-2		比例		第 2 张	
				设计		核准		控制电路图一		标准 CE		共 9 张			
				校对		核准		 信易电热机械股份有限公司 Shini Plastics Technologies, Inc.		机器电压		3φ230V			
标记		更改前		更改后		更改人				日期		20220727		机器频率	

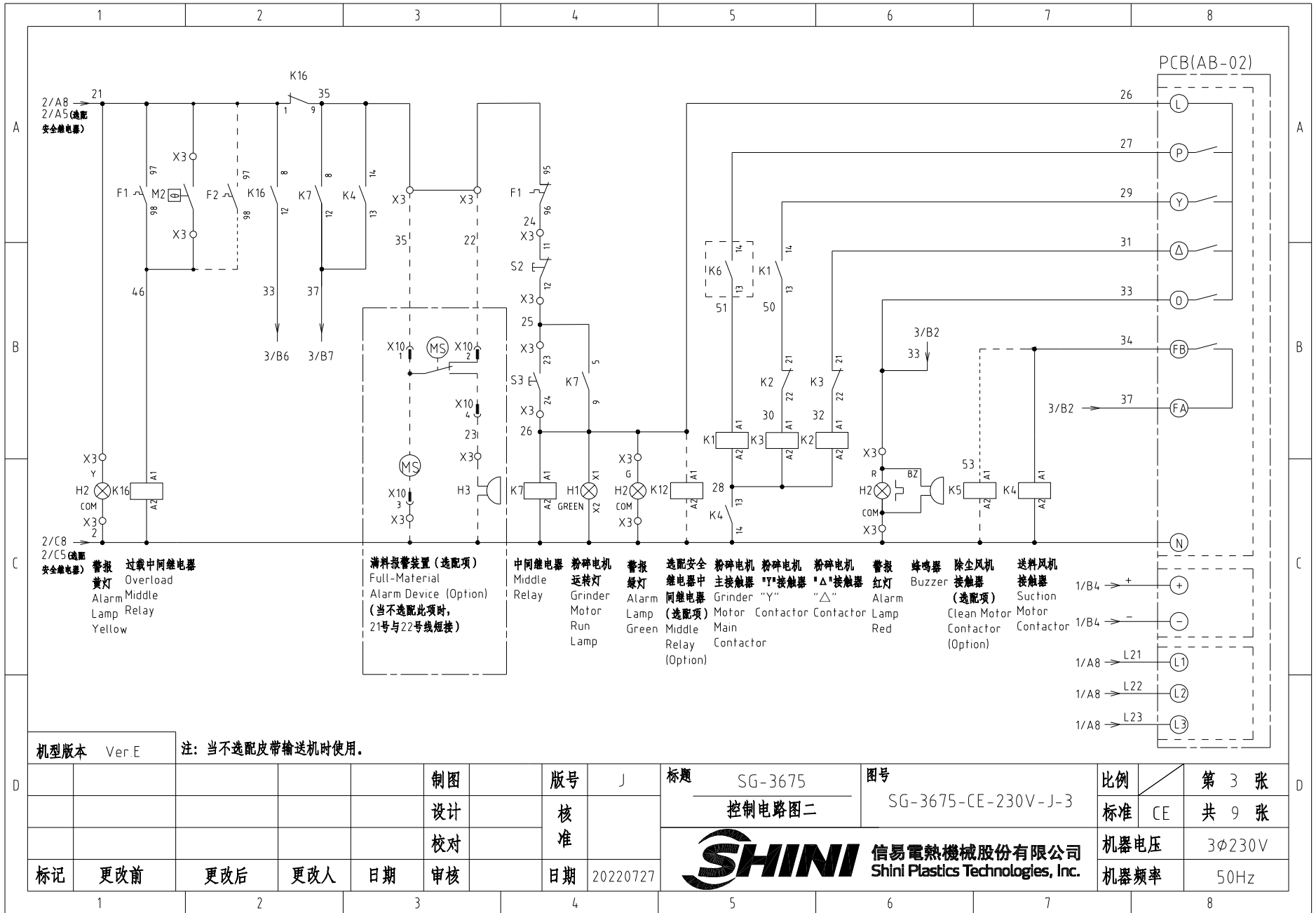

机型版本 Ver.E

注：当不选配皮带输送机时使用。

制图	版号	J	标题	SG-3675 控制电路图二	图号	SG-3675-CE-230V-J-3	比例	第 3 张
设计	核准						标准	CE 共 9 张
校对	核准						机器电压	3φ230V
标记	更改前	更改后	更改人	日期	20220727		机器频率	50Hz



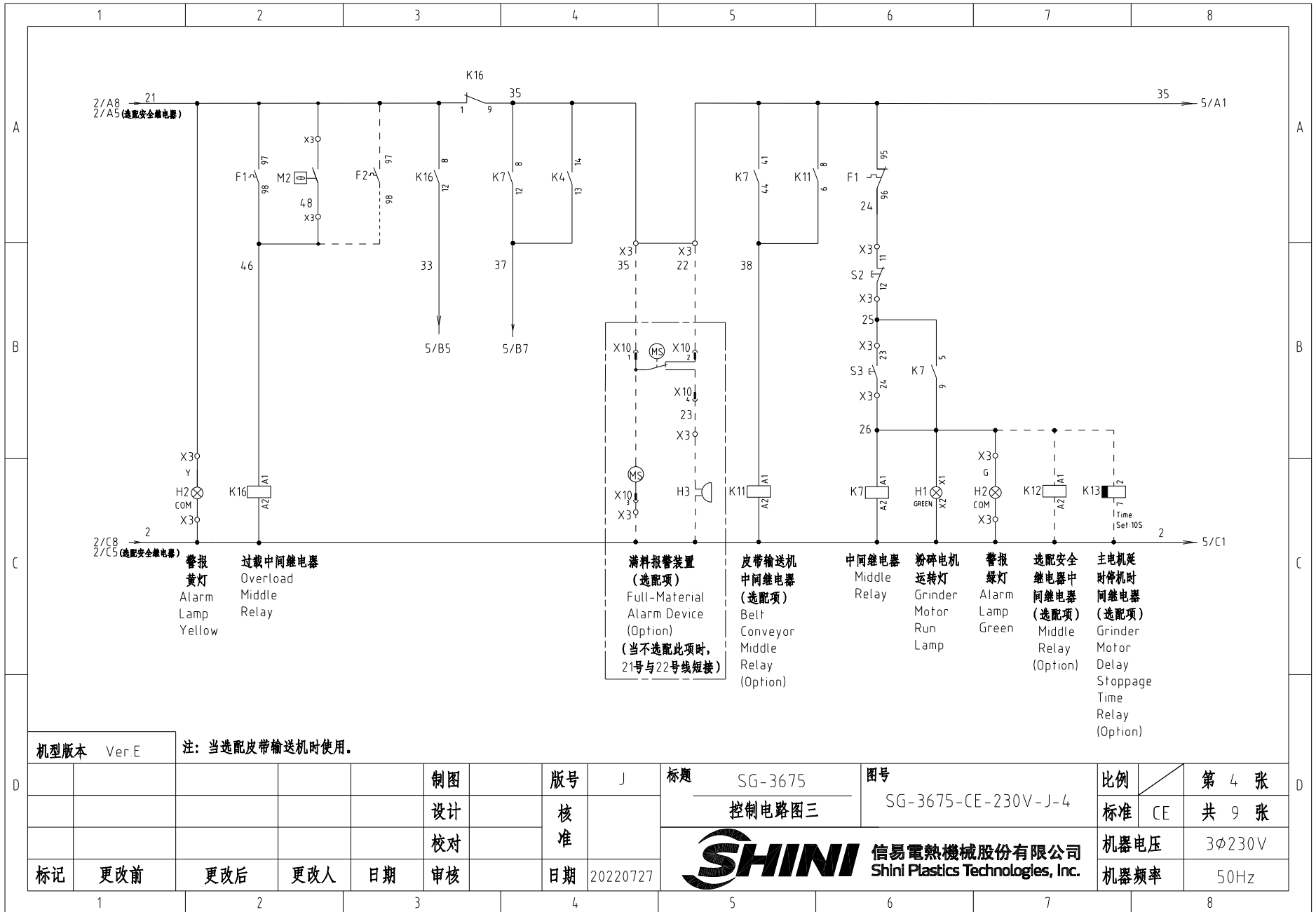

机型版本 Ver.E		注：当选配皮带输送机时使用。			制图	版号 J	标题 SG-3675	图号	比例	第 4 张
					设计	核准	控制电路图三	SG-3675-CE-230V-J-4	标准 CE	共 9 张
					校对	核准	 信易电热机械股份有限公司 Shini Plastics Technologies, Inc.	机器电压	3φ230V	
标记	更改前	更改后	更改人	日期	审核	日期 20220727		机器频率	50Hz	

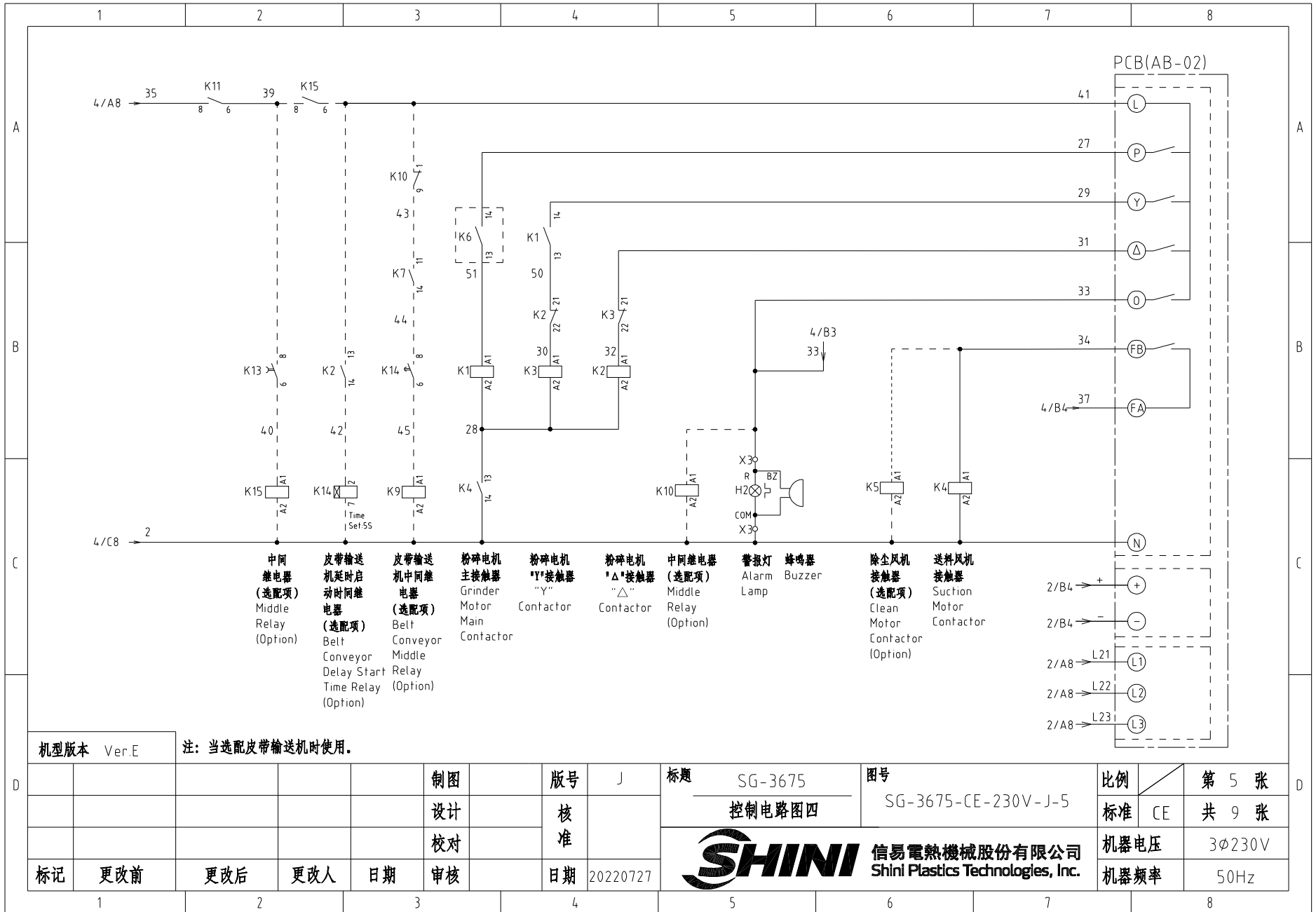

机型版本 Ver.E

注: 当选配皮带输送机时使用。

制图	版号	J	标题	SG-3675	图号	SG-3675-CE-230V-J-5	比例	第 5 张
设计	核准		控制电路图四				标准 CE	共 9 张
校对	核准		信易電熱機械股份有限公司 Shini Plastics Technologies, Inc.		机器电压 3φ230V			
标记	更改前	更改后			更改人	日期	20220727	机器频率 50Hz

选配皮带输送机控制触点接线示意图

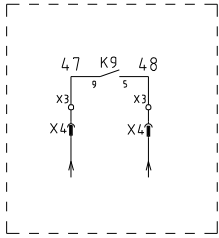

X4 金属接头接线示意图
接皮带输送机
(选配项)

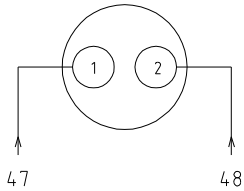

X10 金属接头接线示意图
接满料报警装置
(选配项)

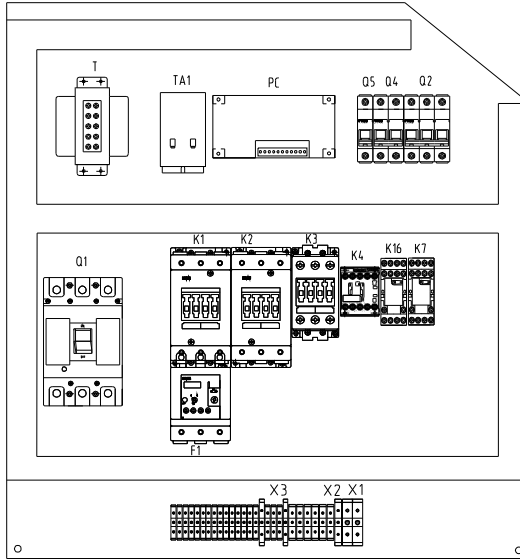
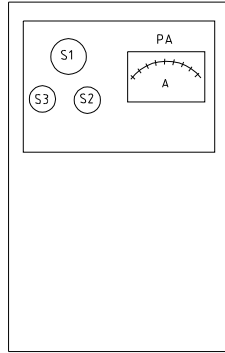
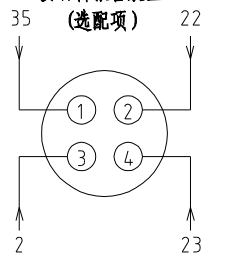

标准机型布局图

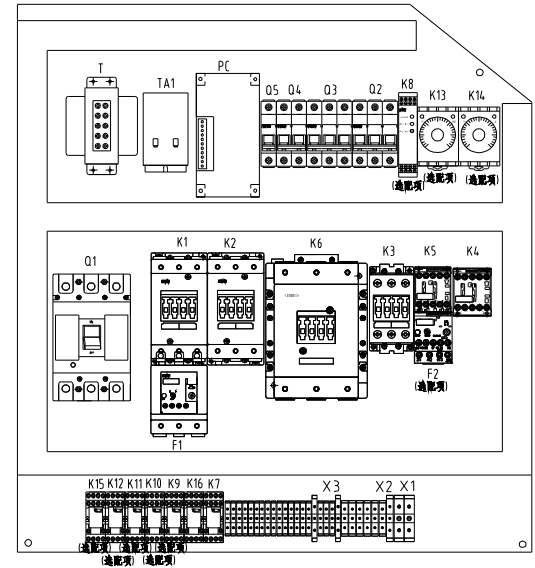

选配机型布局图

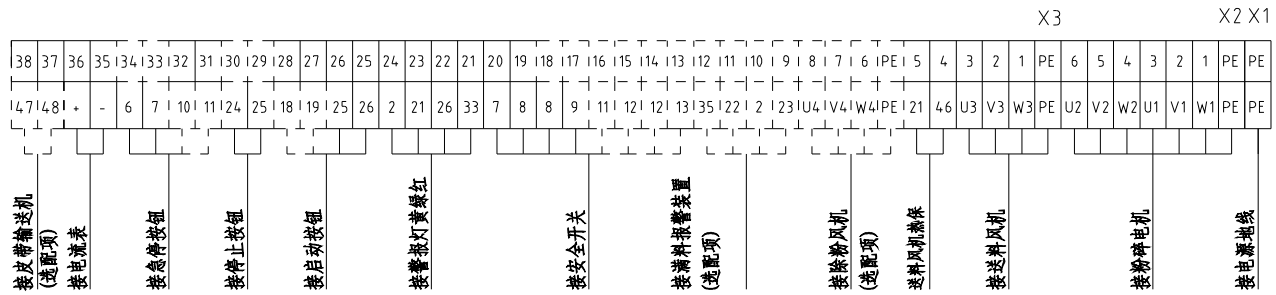

机型版本 Ver E

注：当不选配安全继电器时将6号端子改为3号，9号端子改为21号。

制图	版号	J	标题	SG-3675	图号	SG-3675-CE-230V-J-6	比例	第 6 张
设计	核准		电气元件布置图				标准 CE	共 9 张
校对	核准		信易電熱機械股份有限公司 Shini Plastics Technologies, Inc.	机器电压	3φ230V			
标记	更改前	更改后		更改人	日期	20220727	机器频率	50Hz
1	2	3	4	5	6	7	8	

1		2		3		4		5		6		7		8	
序号/NO	符号/Symbol	名称/Name	制造商/Manufacturer	型号/Type	规格/Specification	数量/Number	物料编号/Material number	备注/Remark							
A	1	Q1	门连锁断路器/Gate circuit breaker	TECO	TAX-250L3160 3P	160A	1	YE40250300400							
	2		断路器外部操作把手/External operating handle	TECO	FB2R-CS1-C-D(TAX-250)3P	-----	1	YE90211200300							
	3	Q2	断路器/Circuit breaker	TECO	BM-63C/3P	16A	1	YE40301603000	(6)						
	4		断路器/Circuit breaker	TECO	BM-63C/3P	16A	1	YE40301603000	(7)						
	5	Q3	断路器/Circuit breaker	TECO	BM-63C/3P	10A	1	YE40301003000	(2)						
	6	Q4	断路器/Circuit breaker	TECO	BM-63C/2003S 2P	3A	1	YE40200203000							
	7	Q5	断路器/Circuit breaker	TECO	BM-63C/1010S 1P	10A	1	YE40101000100							
B	8	K1	接触器/Contactor	SIEMENS	3RT5044-1AC20	65A 24VAC 50/60Hz	1	YE00504402600							
	9		辅助触点/Auxiliary Contactor	SIEMENS	3RH5921-1CA01	1NC	1	YE00592110100	(4)						
	10		辅助触点/Auxiliary Contactor	SIEMENS	3RH5921-1CA10	1NO	1	YE00592110000							
	11	K2	接触器/Contactor	SIEMENS	3RT5044-1AC20	65A 24VAC 50/60Hz	1	YE00504402600							
	12		辅助触点/Auxiliary Contactor	SIEMENS	3RH5921-1CA01	1NC	1	YE00592110100							
	13		辅助触点/Auxiliary Contactor	SIEMENS	3RH5921-1CA10	1NO	1	YE00592110000	(5)						
	14	K3	接触器/Contactor	SIEMENS	3RT5036-1AC20	50A 24VAC 50/60Hz	1	YE00503602600							
15		辅助触点/Auxiliary Contactor	SIEMENS	3RH5921-1CA01	1NC	1	YE00592110100								
C	16	K4	接触器/Contactor	SIEMENS	3RT6016-1AB01	9A 24VAC 50/60Hz	1	YE00601602500	(6)						
	17	K4	接触器/Contactor	SIEMENS	3RT6017-1AB01	12A 24VAC 50/60Hz	1	YE00601702500	(7)						
	18		辅助触点/Auxiliary Contactor	SIEMENS	3RH6911-1HA11	1NC+1NO	1	YE00691100100							
	19	K5	接触器/Contactor	SIEMENS	3RT6016-1AB02	9A 24VAC 50/60Hz	1	YE00601602600	(2)						
	20	K6	接触器/Contactor	SIEMENS	3RT5054-1AB36	115A 24VAC 50/60Hz	1	YE00505400900	(4)						
	21		辅助触点/Subsidiary Contactor	SIEMENS	3RH5921-1CA10	1NO	1	YE00592110000	(4)						
	22	K7	中间继电器/Middle relay	Honeywell	GR-2C-AC24V	24VAC	1	YE03022400300							
23	K7	中间继电器/Middle relay	Honeywell	GR-4C-AC24V	24VAC	1	YE03042400300	(5)							
24	K8	安全继电器/Safety relay	PILZ	PNOZ×2.8P	24V AC/DC	1	YE04023000000	(4)							
25	T	互感变压器/Transformer	-----	IN=230V/200V OUT=24V	230VA	1	YE70023006100	选配(4)时去掉							
机型版本 Ver E		注: (1)表示非电控箱内材料; (2)表示除尘马达选配; (3)表示满料报警装置选配; (4)表示安全继电器选配; (5)表示皮带输送机选配; (6)表示选用标准风机选项; (7)表示增大送料风机功率选项。													
D					制图	版号 J		标题 SG-3675	图号 SG-3675-CE-230V-J-7		比例	第 7 张			
					设计	核		电气元件明细表一		标准 CE	共 9 张				
					校对	准		 信易电热机械股份有限公司 Shini Plastics Technologies, Inc.		机器电压	3φ230V				
	标记	更改前	更改后	更改人	日期	审核	日期			20220727	机器频率	50Hz			
1		2		3		4		5		6		7		8	

1		2		3		4		5		6		7		8				
序号/NO	符号/Symbol	名称/Name		制造商/Manufacturer		型号/Type		规格/Specification		数量/Number	物料编号/Material number		备注/Remark					
A	26	T	互感变压器/Transformer		----		IN=230/200V OUT=24VAC		300VA		1	YE70023005000		(4)				
	27	K9 K10 K11 K15	中间继电器/Middle relay		Honeywell		GR-2C-AC24V		24VAC		4	YE03022400300		(5)				
	28	K12	中间继电器/Middle relay		Honeywell		GR-2C-AC24V		24VAC		1	YE03022400300		(4)				
	29	K13	定时器/Timer		YUYUN		TRF-N/3M		24VAC		1	YE86032400000		(5)				
	30	K14	定时器/Timer		YUYUN		TH3A-NAB 60S		24VAC		1	YE86602400300		(5)				
	31	K16	中间继电器/Middle relay		Honeywell		GR-2C-AC24V		24VAC		1	YE03022400300						
	32	F1	热过载继电器/Overload relay		SIEMENS		3RU5146-4 JB0		45-63A		1	YE01514640000						
B	33	F2	热过载继电器/Overload relay		SIEMENS		3RU1116-1EB0		2.8-4A		1	YE01160280000		(2)				
	34	X1	端子排/Terminal		NACHI		NCT-50PE		50mm ² PE		1	YE61005040100						
	35	X2	端子排/Terminal		HoneyWell		GK16		16mm ²		6	YE60001603200						
	36				HoneyWell		GK16PE		16mm ² PE		1	YE60001603500						
	37	X3	端子排/Terminal		HoneyWell		SK2.5		2.5mm ²		21	YE60002503200						
	38				HoneyWell		GK2.5PE		2.5mm ² PE		1	YE60002503400						
	39				HoneyWell		SK2.5		2.5mm ²		3	YE60002503200		(2)				
	40				HoneyWell		GK2.5PE		2.5mm ² PE		1	YE60002503400		(2)				
C	41				HoneyWell		SK2.5		2.5mm ²		4	YE60002503200		(3)				
	42				HoneyWell		SK2.5		2.5mm ²		8	YE60002503200		(4)				
	43				HoneyWell		SK2.5		2.5mm ²		2	YE60002503200		(5)				
	44	X4	金属接头/Metal tie in		SHINI		PLT-162-RR(公)		2P		1	YE68016200100		(1)(5)				
	45	X10	金属接头/Metal tie in		SHINI		PLT-254PM		4P		1	YE68025400000		(1)(3)				
	46				SHINI		PLT-254RF		4P		1	YE68025400100		(1)(3)				
	47	S1	急停按钮/Emergency stop button		SCHNEIDER		XB2BS542C		400VAC		1	YE11254200000		(1)				
48		触点块/Contact block		SCHNEIDER		ZB2BE102C		1NC		1	YE00210203100		(1)(4)					
49	S2	停止按钮/Stop button		SCHNEIDER		XB2BA22C		400VAC		1	YE11222000000		(1)					
50	S3,H1	启动按钮(带灯)/Start button		SCHNEIDER		XB2BW33B1C		24VAC		1	YE11233100000		(1)					
D	机型版本 Ver.E		注: (1)表示非电控箱内材料;(2)表示除尘马达选配件;(3)表示满料报警装置选配件;(4)表示安全继电器选配件;(5)表示皮带输送机选配件;(6)表示选用标准风机选项;(7)表示增大送料风机功率选项。															
						制图		版号	J	标题	SG-3675		图号			比例	第 8 张	
						设计		核		电气元件明细表二		SG-3675-CE-230V-J-8		标准	CE	共 9 张		
						校对		准		 信易電熱機械股份有限公司 Shini Plastics Technologies, Inc.		机器电压		3φ230V				
标记	更改前	更改后	更改人	日期	审核	日期	20220727	机器频率				50Hz						

1		2		3		4		5		6		7		8	
序号/NO	符号/Symbol	名称/Name	制造商/Manufacturer	型号/Type	规格/Specification	数量/Number	物料编号/Material number	备注/Remark							
51		触点块/Contact block	SCHNEIDER	ZB2BE101C	1NO	1	YE00210103100	(1)(4)							
52	S4,S5	安全开关/Safety switch	SCHMERSRC	AZ15-02ZVRK-1476	AZ-15	2	YE16147600100	(1)							
53	S4,S5	安全开关/Safety switch	SCHMERSRC	AZ16-02ZVRK-1476	AZ-16	2	YE16147600000	(1)(4)							
54	H2	三色警报灯/Alarm lamp	SHINI	红绿黄优先顺序+蜂鸣器	24 VAC	1	BL90002401520	(1)							
55	H3	蜂鸣器/Buzzer	TEND	EA-2	24 VAC	1	YE84240200000	(1)(3)							
56	MS	料位开关/Feed position motor	SIPAI	SR-80	24 VAC	1	YE15802400100	(1)(3)							
57	PA	电流表/Galvanometry	SFIM	DH-670	150/5A	1	YE25671500000	(1)							
58	TA1	电流互感器/Current mutual inductance	RATIO	RCT-35	150/5A	1	YE04150500000								
59	TA2	电流互感器/Current mutual inductance	YUYUN	-----	5-100A	1	-----	线路板自带							
60	PCB	微电脑板/PCB	YUYUN	AB-02	24 VAC	1	YE80022400100								
61	M1	粉碎电机/Granulating motor	SIEMENS	30KW	230V 60HZ	1	-----	(1)							
62	M2	吸料风机/Solution blower	SHINI	1.5KW	230V 60HZ	1	-----	(1)(6)							
63	M2	吸料风机/Solution blower	SHINI	2.2KW	230V 60HZ	1	-----	(1)(7)							
64	M3	除尘风机/Dust blower	SHINI	0.75KW	230V 60HZ	1	-----	(1)(2)							
		终端固定件	HONEYWELL	-----	-----	4	YE60000003900								
C															
D															
机型版本 Ver E		注: (1)表示非电控箱内材料; (2)表示除尘马达选配件; (3)表示满料报警装置选配件; (4)表示安全继电器选配件; (5)表示皮带输送机选配件; (6)表示选用标准风机选项; (7)表示增大送料风机功率选项。													
				制图		版号 J		标题 SG-3675		图号		比例		第 9 张	
				设计		核准		电气元件明细表三		SG-3675-CE-230V-J-9		标准 CE		共 9 张	
				校对		核准		 信易電熱機械股份有限公司 Shini Plastics Technologies, Inc.		机器电压		3φ230V			
标记		更改前		更改后		更改人				日期		20220727		机器频率	
1		2		3		4		5		6		7		8	