

# **SEL**

## **Shini Central Material Distribution Station**

Date: December 2024

Version: Ver.D

## Contents

<b>1. General Description .....</b>	<b>4</b>
1.1 Coding Principle .....	5
1.2 Features .....	5
1.3 Machine Specification .....	7
1.3.1 Outline Drawings .....	7
1.3.2 Machine Specification .....	7
1.4 Exemption Clause .....	8
<b>2. Structure Characteristics and Working Principle .....</b>	<b>9</b>
2.1 Working Principle .....	9
2.2 Detection Induction Device .....	10
<b>3. Application and Operation.....</b>	<b>11</b>
3.1 Usage Conditions .....	11
3.1.1 Machine Location .....	11
3.1.2 Power connection.....	12
3.1.3 Air source connection.....	12
3.1.4 How to establish communication and notices.....	12
3.2 Operation Notices.....	12
3.2.1 Start-up and manual testing .....	12
3.2.2 Shutdown .....	15
<b>4. Common Faults and Troubleshooting.....</b>	<b>16</b>
4.1 Troubleshooting.....	16
4.2 The List of Easy Broken Parts .....	16
<b>5. Equipment Maintenance .....</b>	<b>17</b>
5.1 Machine Information .....	17
5.2 Installation and Checking .....	17
5.3 Daily Checking .....	17
5.4 Weekly Checking.....	17

## Table Index

Table 1-1: Machine Specification .....	7
Table 4-1: Troubleshooting.....	16
Table 4-2: Easy Broken Parts.....	16

## Picture Index

Model 1-1: Shini Central Material Distribution Station SEL-2020 .....	4
Picture 1-2:Outline Drawings.....	7
Picture 2-1: Working Principle.....	9
Picture 2-2: Detection Induction Device .....	10
Picture 3-1: Installation and Usage Conditions.....	11
Picture 3-2: Start-up Screen .....	13
Picture 3-3: System Working Screen.....	13
Picture 3-4: Pulse Value Screen.....	14
Picture 3-5: Manual Control Screen.....	14
Picture 3-6: Return to Origin Screen.....	15
Picture 3-7: Manual Test Screen.....	15

## 1. General Description



Read this manual carefully before operation to prevent personal injuries or damage of the machine.

One set of central material distribution station can control 20 material sources and 20 terminals at most, which enables the configuration of one material to any terminal.

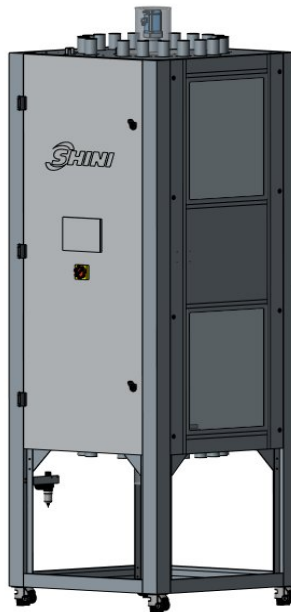

Model 1-1: Shini Central Material Distribution Station SEL-2020

## 1.1 Coding Principle

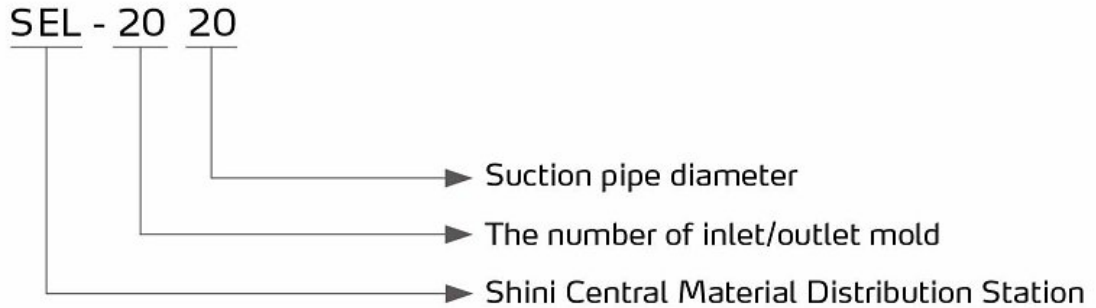

## 1.2 Features

- 1) Vertical design with small footprint that saves the space.
- 2) Servo driven motor ensures precise positioning, simple and efficient.
- 3) The fully automatic operation is achieved through PLC control, and the manual control is also available. Human-friendly interface is also available.
- 4) Localization monitoring function ensures correct pipe connection.
- 5) Failure auto alarm function.
- 6) Fully automatic conveying without operation avoid human mistake and pollution.
- 7) Remote control function monitors the material source and flow.
- 8) All use the hard pipe connection features long durability and less maintenance.
- 9) One set of central material distribution station can control 20 material sources and 20 terminals at most, which enables the configuration of one material to any terminal.

All maintenance work should be carried out by a person with technical training or corresponding professional experience. This manual is suitable for operators and maintenance personnel on-site.

Any modifications of the machine must be approved by SHINI in order to avoid personal injury and damage to machine. We shall not be liable for any damage caused by unauthorized change of the machine.

Our company provides after-sales service. Should you have any problem during using the machine, please contact the company or the local vendor.

Headquarter and Taipei factory:

Tel: + 886 (0)2 2680 9119

Shini Plastics Technologies (Dongguan), Inc.:

+86 (0)769 8331 3588

Shini Plastics Technologies (Pinghu), Inc.:

+86 (0)573 8522 5288

Shinden Precision Machinery (Chongqing), Inc.:

+86 (0)23 6431 0898

## 1.3 Machine Specification

### 1.3.1 Outline Drawings

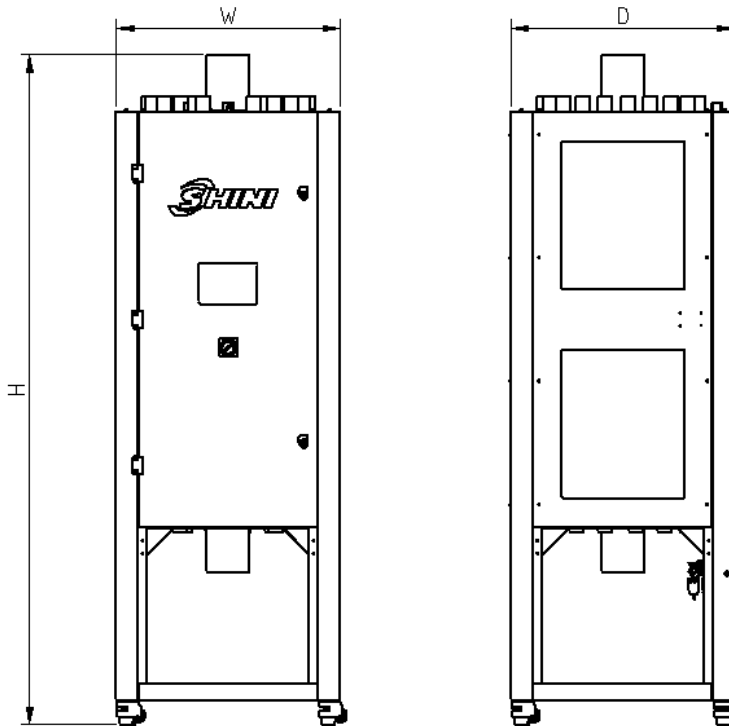

Picture 1-2:Outline Drawings

### 1.3.2 Machine Specification

Table 1-1: Machine Specification

Model	SEL-2020
Total power ( kw )	0.8
Inlet air pipe size(mm)	8
Suction pipe diameter (inch)	2
External size (W×D×H)(mm)	850×850×2690
Weight(kg)	260

Note:1)Power voltage:1Φ, 220VAC, 50Hz We reserve the right to change specifications without prior notice.

## 1.4 Exemption Clause

The following statements clarify the responsibilities and regulations born by any buyer or user who purchases products and accessories from Shini (including employees and agents).

Shini is exempted from liability for any costs, fees, claims and losses caused by reasons below:

- 1) Any careless or man-made installations, operation and maintenance upon machines without referring to the Manual prior to machine using.
- 2) Any incidents beyond human controls, which include man-made vicious or deliberate damages or abnormal power, and machine faults caused by irresistible natural disasters including fire, flood, storm and earthquake.
- 3) Any operational actions that are not authorized by Shini upon equipment, including adding or replacing accessories, dismantling, delivering or repairing.
- 4) Employing consumables or oil media that are not appointed by Shini.



## 2. Structure Characteristics and Working Principle

### 2.1 Working Principle

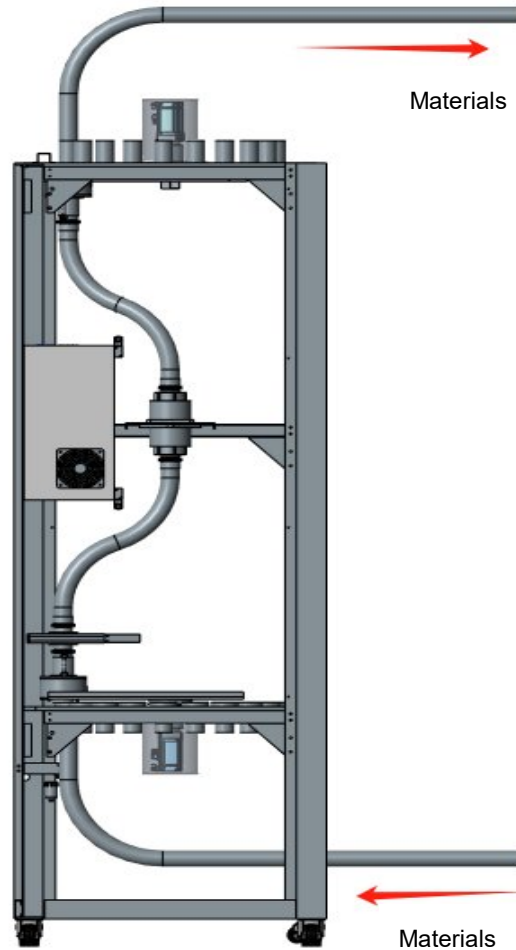

Picture 2-1: Working Principle

The upper and lower rotary plates rotate to the required hopper and material pipe positions, and the cylinder pushes the joint to connect with the pipe positions on the plate, forming a closed channel inside the distribution station. After the blower starts to work, the shut-off air refilling valve opens, and the materials are transported to the hopper through the distribution station. The shut-off suction box and the shut-off air refilling valve are closed, the pipeline is cleared, the cylinder is retracted, and the suction is completed. Wait for the next shortage signal, the rotary plate will turn to the corresponding position, and repeat the above action.

## 2.2 Detection Induction Device

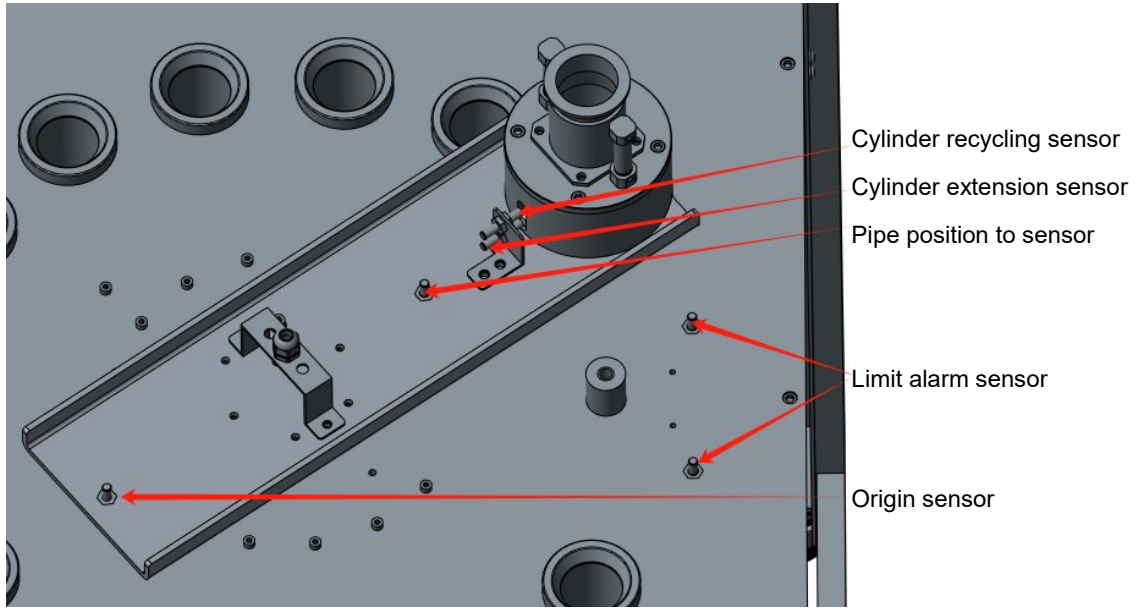

Picture 2-2: Detection Induction Device

## 3. Application and Operation

### 3.1 Usage Conditions

#### 3.1.1 Machine Location

- 1) The machine can only be installed in vertical position, make sure there's no pipeline, fixed structure and other object that may obstruct machine installation or cause item damage, human injuries above the selected location and adjacent areas.
- 2) For easy maintenance, leaving 1m space around machine is suggested. A distance of at least 1.5 meters should be reserved on the machine top as a space for connecting pipes. The upper pipeline should use steel wire pipes with smooth inner walls.
- 3) The machine must be placed on the ground level to ensure balance state. If machine is need to install on a higher level (scaffolding or interlayer), it should make sure that the structure and size could withstand the machine.

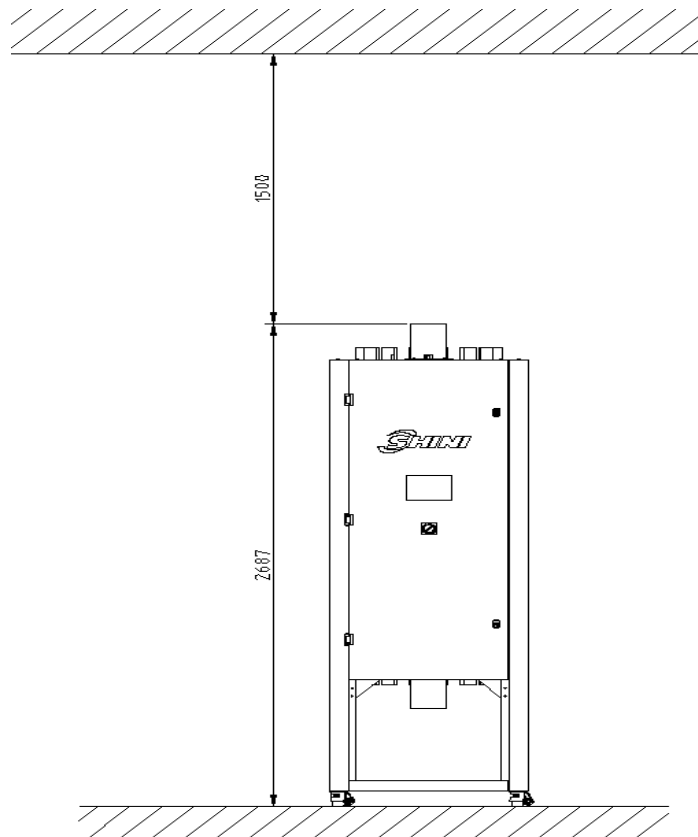

Picture 3-1: Installation and Usage Conditions

### 3.1.2 Power connection

- 1) Make sure the voltage and frequency of the power source comply with those indicated on the manufacturer nameplate that attached to the machine.
- 2) Make sure the voltage and frequency of the power source comply with those indicated on the manufacturer nameplate that attached to the machine.

Use independent electrical wires and power switch. Diameter of electrical wire should not be less than those used in the control box.

The power cable connection terminals should be tightened securely.

- 3) Power supply requirements:

Main power voltage: +/- 5%

Main power frequency: +/- 2%

***Please refer to electrical drawing of each model to get the detailed power supply specifications***

### 3.1.3 Air source connection

- 1) Gas supply uses 4kgf/cm<sup>2</sup> (0.4MPa).

### 3.1.4 How to establish communication and notices

- 1) Communication can be achieved through Ethernet. This machine supports Siemens S7 communication and modbus RTU/TCP.
- 2) The central material distribution station operates fully automatically when in operation. Pre-set corresponding machines of different materials and connect the upper and lower feeding pipes. After start up, the upper and lower workstations will be reset automatically, and then the pipe position can be matched according to the shortage signal.

## 3.2 Operation Notices

### 3.2.1 Start-up and manual testing

- 1) Switch the main power switch to ON, and turn it on to enter the control screen below.

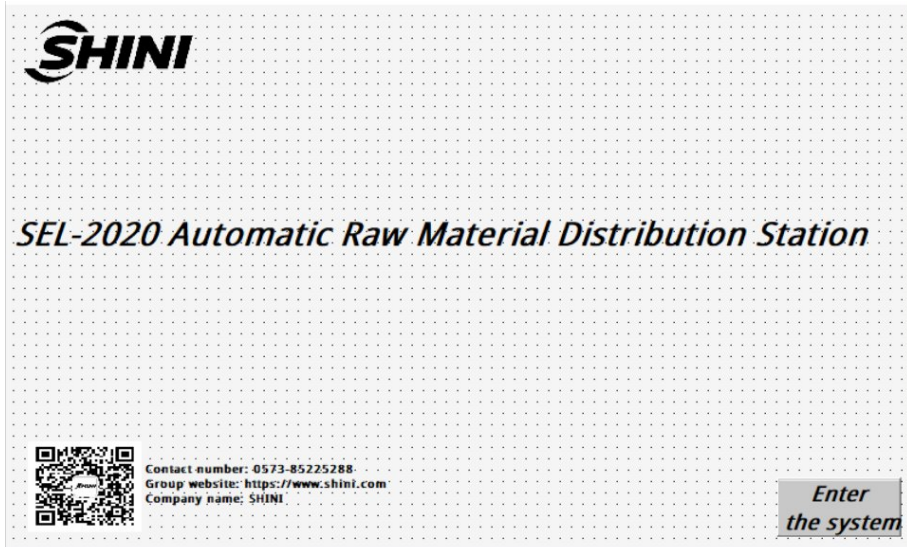

Picture 3-2: Start-up Screen

- 2) Click to enter the system and enter the system work screen .

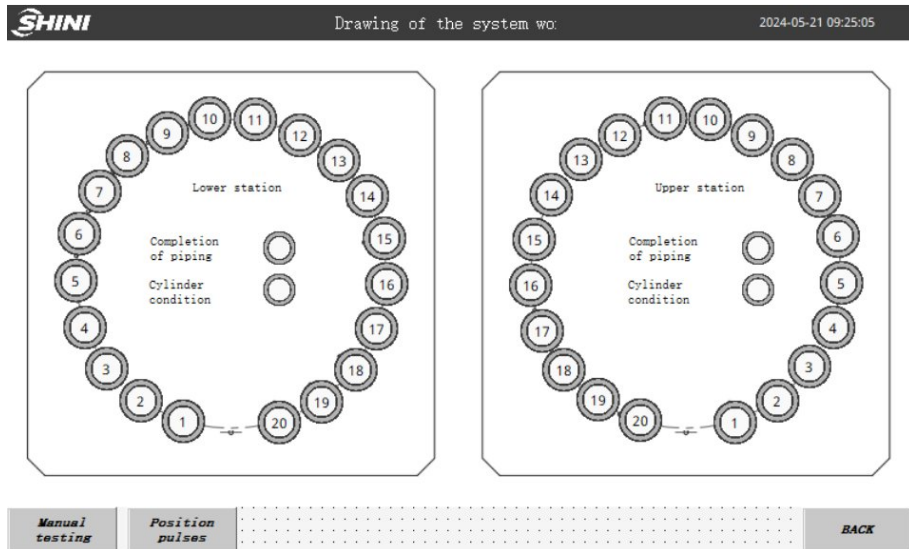

Picture 3-3: System Working Screen

- 3) Click on the pipe position pulse to enter the control screen below (Pulse data control of motor rotation angle). Non-professional personnel are not allowed to modify this data.

NO	setpoint	NO	setpoint	NO	setpoint	NO	setpoint
Upper tube position 1	00000	Upper tube position 11	00000	Lower tube position 1	00000	Lower tube position 11	00000
Upper tube position 2	00000	Upper tube position 12	00000	Lower tube position 2	00000	Lower tube position 12	00000
Upper tube position 3	00000	Upper tube position 13	00000	Lower tube position 3	00000	Lower tube position 13	00000
Upper tube position 4	00000	Upper tube position 14	00000	Lower tube position 4	00000	Lower tube position 14	00000
Upper tube position 5	00000	Upper tube position 15	00000	Lower tube position 5	00000	Lower tube position 15	00000
Upper tube position 6	00000	Upper tube position 16	00000	Lower tube position 6	00000	Lower tube position 16	00000
Upper tube position 7	00000	Upper tube position 17	00000	Lower tube position 7	00000	Lower tube position 17	00000
Upper tube position 8	00000	Upper tube position 18	00000	Lower tube position 8	00000	Lower tube position 18	00000
Upper tube position 9	00000	Upper tube position 19	00000	Lower tube position 9	00000	Lower tube position 19	00000
Upper tube position 10	00000	Upper tube position 20	00000	Lower tube position 10	00000	Lower tube position 20	00000

**BACK**

Picture 3-4: Pulse Value Screen

- Click on manual control to enter the following screen, which is for manual control test of the machine.

**SHINI**Manual test of the pictu2024-05-21 09:24:55

Upper tube position

Position 1	Position 2	Position 3	Position 4	Position 5	Position 6	Position 7	Position 8	Position 9	Position 10

Position 11	Position 12	Position 13	Position 14	Position 15	Position 16	Position 17	Position 18	Position 19	Position 20

---

Down tube position

Position 1	Position 2	Position 3	Position 4	Position 5	Position 6	Position 7	Position 8	Position 9	Position 10

Position 11	Position 12	Position 13	Position 14	Position 15	Position 16	Position 17	Position 18	Position 19	Position 20

Upper Origin:

Lower Origin:

00000 pulses/sec

00000 pulses/sec

**BACK**

to set the speed      set speed

Picture 3-5: Manual Control Screen

- Click the up and down origin buttons to control the pipeline to return to the origin.
- Set the speed upper and lower limits, and operating speed of the pipeline.



Picture 3-6: Return to Origin Screen

- 7) Click on any upper or lower pipe positions. Observe if the pipeline has been selected correctly and whether there's alarm prompt.

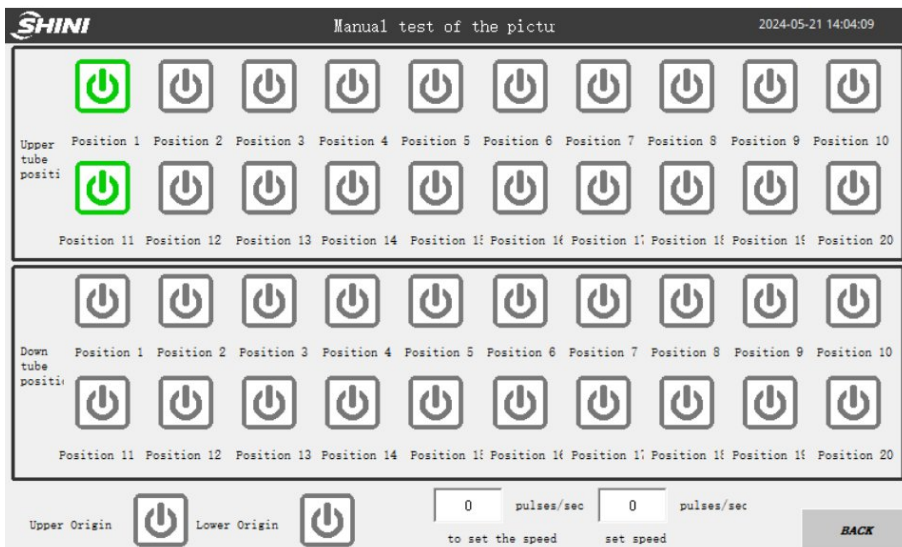

Picture 3-7: Manual Test Screen

### 3.2.2 Shutdown

Exit all pipeline selections, return to the origin, and switch the main power to OFF.

## 4. Common Faults and Troubleshooting

### 4.1 Troubleshooting

Table 4-1: Troubleshooting

Faults	Possible Reasons	Troubleshooting Method
Insufficient air pressure	Insufficient air pressure	Check the pressure of pressure regulating valve.
	Pressure controllers are set incorrectly.	Check the pressure controller settings.
Upper / lower cylinders are not lowered.	Abnormal cylinder action	Check the control solenoid valve.
	Sensor not detected.	Sensor loose or damaged
Upper / lower cylinders not retracted.	Abnormal cylinder action	Check the control solenoid valve.
	Sensor not detected.	Sensor loose or damaged
The upper/lower cylinders are not in place.	Position deviated, not reaching the middle of the pipe	Loosen the material pipe and adjust its position.
Up / down positioning out of range	Origin sensor not detected	Check the origin sensor.
Up / down drive failure	Origin sensor not detected	Check the origin sensor.
	Position deviated, not reaching the middle of the pipe	Loosen the material pipe and adjust its position.

### 4.2 The List of Easy Broken Parts

Table 4-2: Easy Broken Parts

Drawing No. / Material No.	Name	Quantity
YE80043800100	Proximity sensor	10
YE30122000700	Mini cylinder	4
YE32421000300	Solenoid valve	3
YE10206000100	Fixed cylinder	1
YM50303300000	Servo motor + driver	2
YM50090000100	Reducer VRT090-020-S2-P2-14-50-70-M5(Feng Hua)	2
YE90051000600	Pressure controller	1
YR20526000000	Skeleton oil seal	2
YE50707000100	Touch panel	1
SEL-1420-B-12	Connecting elbow	2



## 5. Equipment Maintenance

### 5.1 Machine Information

Model \_\_\_\_\_ Series No. \_\_\_\_\_ Manufacture Date \_\_\_\_\_

Voltage \_\_\_  $\Phi$  \_\_\_\_\_ V Frequency \_\_\_\_\_ Hz Power \_\_\_\_\_ kW

### 5.2 Installation and Checking

Check if the screw is correctly installed.

Check if all sensors are working properly.

Electrical installation

Machine power \_\_\_\_\_ V \_\_\_\_\_ Hz

Fuse specification: 1 $\Phi$  \_\_\_\_\_ A 3 $\Phi$  \_\_\_\_\_ A

Check whether the control box power and signal wires are connected correctly.

### 5.3 Daily Checking

Check the main power switch

Check whether the control box metal connectors are loose.

### 5.4 Weekly Checking

Check all power cables of the machine for damage.

Check whether the fixed screws of reducer motor are loose.