

机型版本 Ver.B

				制图		版号 A		标题 SCD-40Ux2-80H		图号		比例		第 1 张	
				设计		核准		主电路图一		SCD-40Ux2-80H-CE-400V-A-1		标准 CE		共 10 张	
				校对		核准		 信易電熱機械股份有限公司 Shini Plastics Technologies, Inc.		机器电压		3φ400V			
标记		更改前		更改后		更改人				日期		20240520		机器频率	

1 2 3 4 5 6 7 8

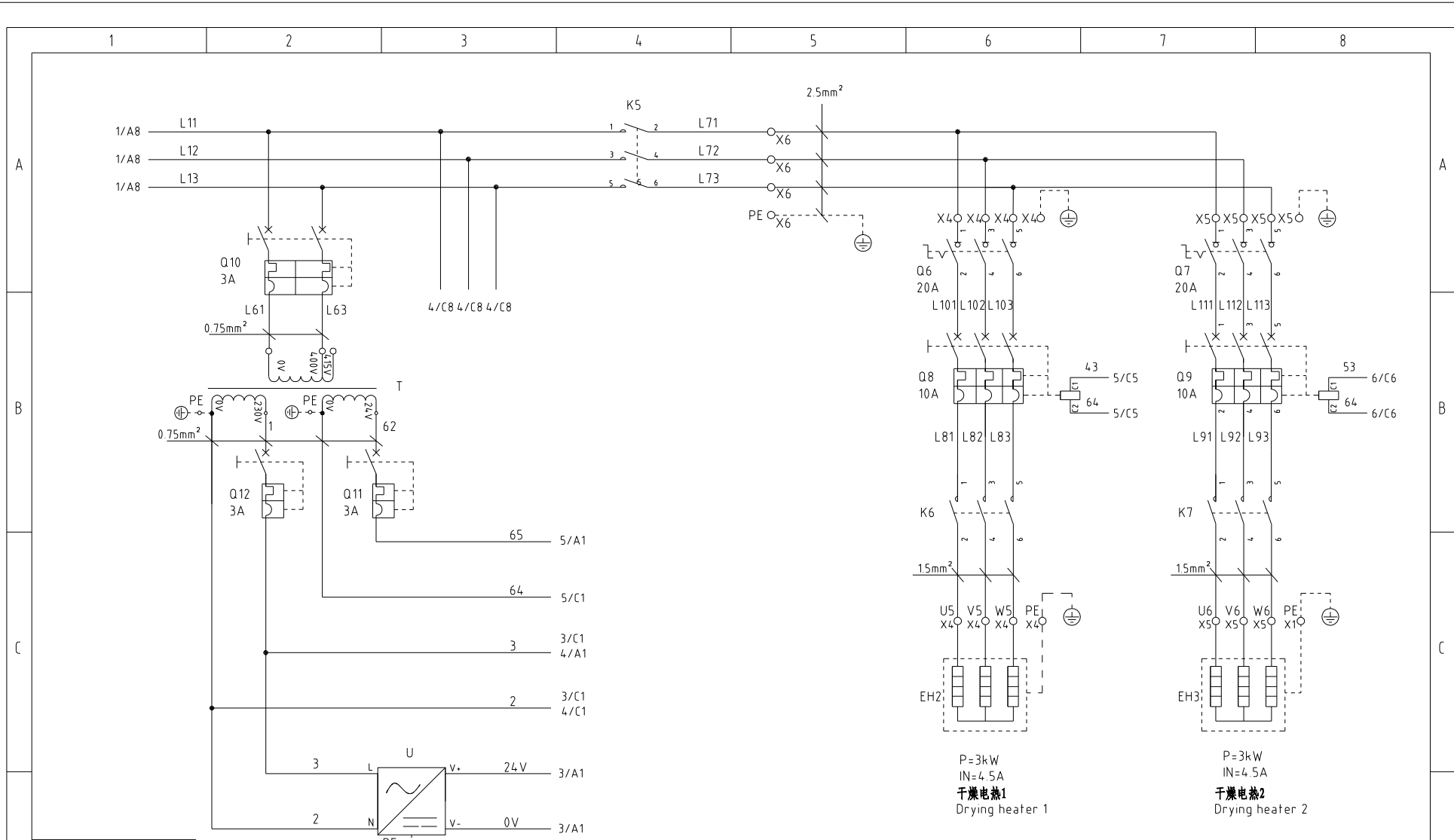

机型版本 Ver.B

						制图	版号	A	标题	SCD-40U×2-80H	图号	SCD-40U×2-80H-CE-400V-A-2	比例	第 2 张
						设计	核准		主电路图二		标准	CE	共 10 张	
						校对	核准		 <b>信易电热机械股份有限公司</b> <b>Shini Plastics Technologies, Inc.</b>	机器电压	3φ400V			
标记	更改前	更改后	更改人	日期	审核	日期	2024.05.20	机器频率		50Hz				

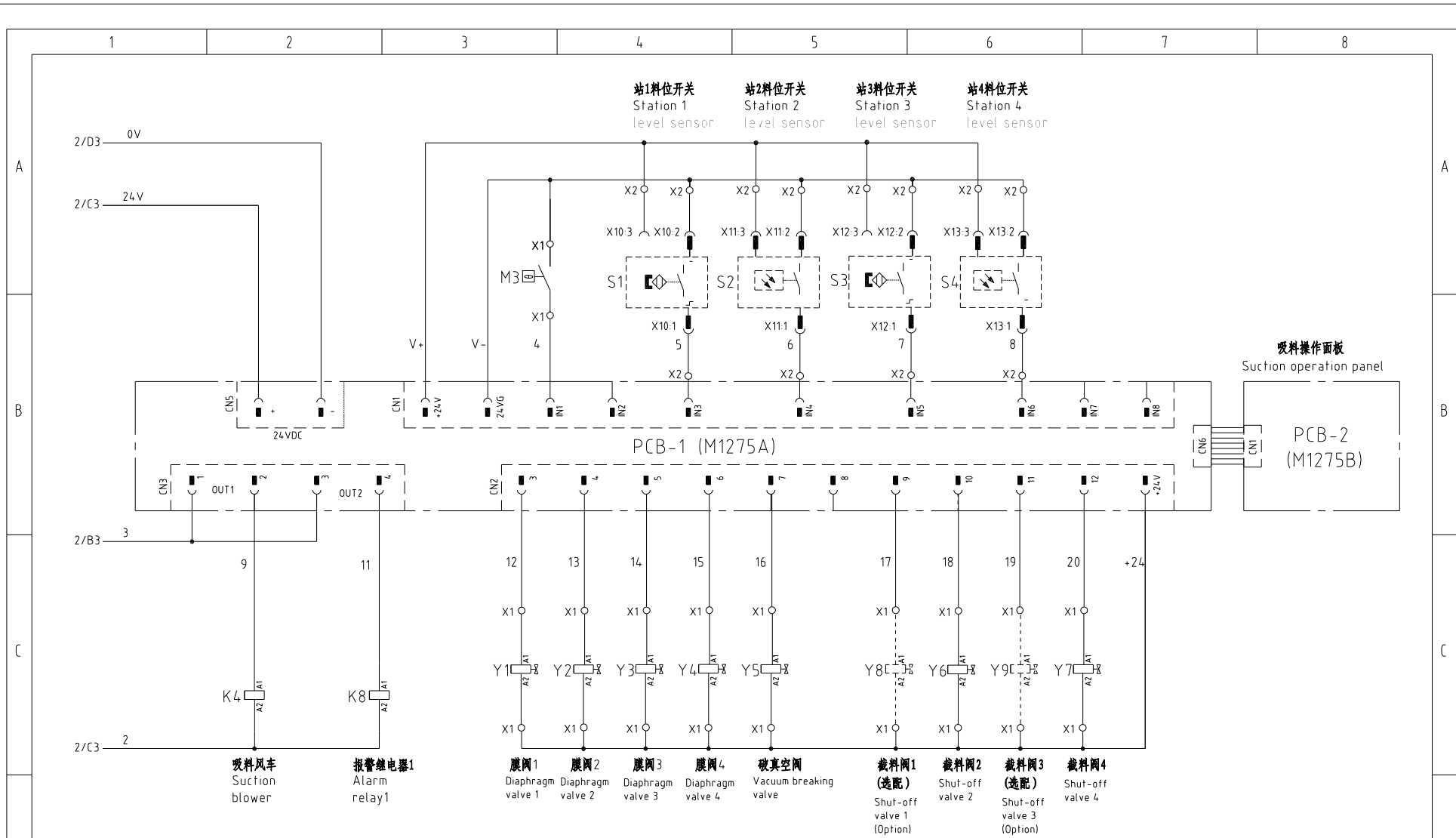

机型版本 Ver.B

					制图	版号	A	标题	SCD-40Ux2-80H	图号	SCD-40Ux2-80H-CE-400V-A-3	比例	第 3 张
					设计	核准		控制电路图一				标准	CE
					校对	核准						机器电压	3φ400V
标记	更改前	更改后	更改人	日期	审核	日期	2024.05.20					机器频率	50Hz



信易电热机械股份有限公司  
Shini Plastics Technologies, Inc.

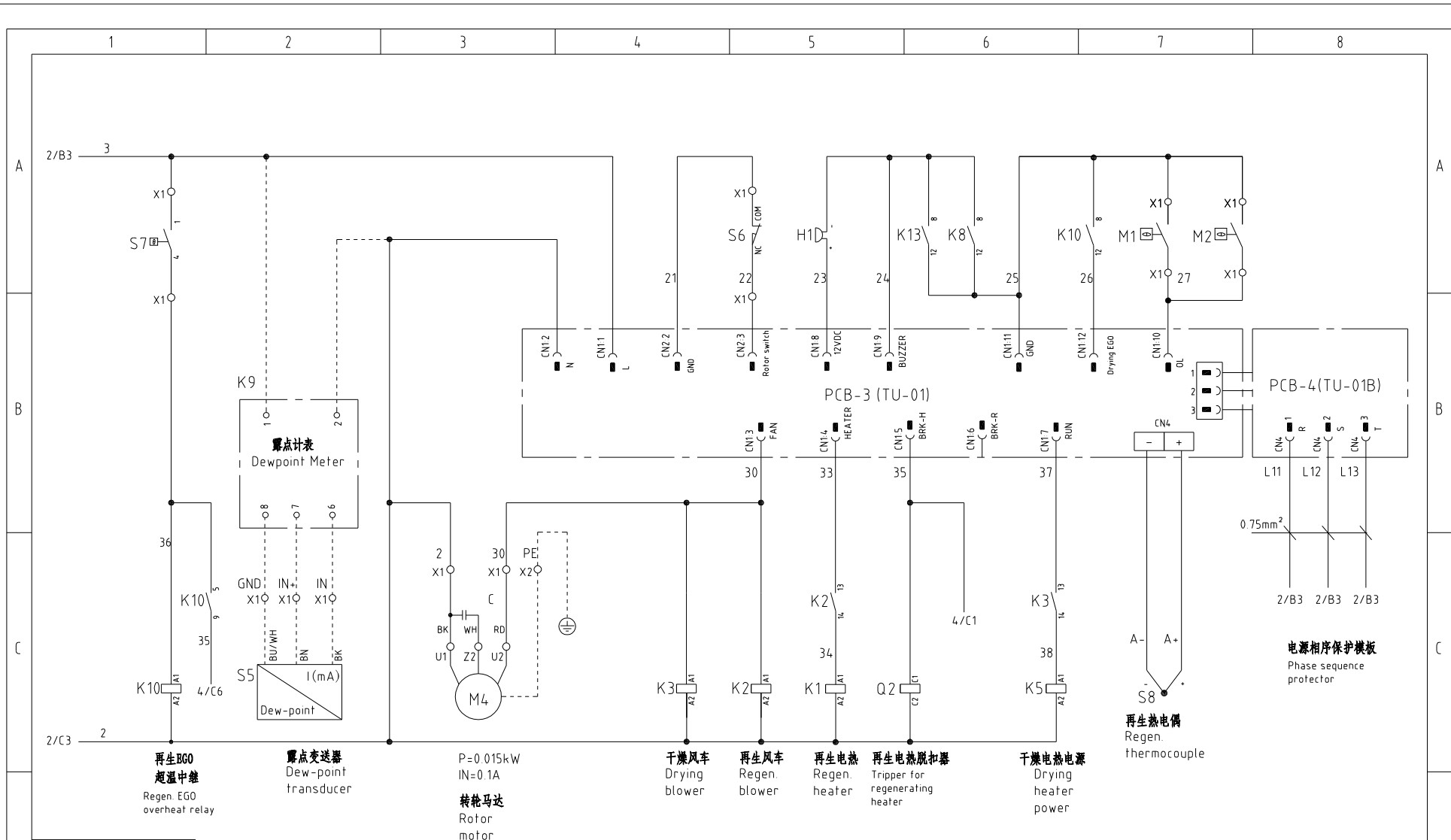

再生BGO  
超温中继  
Regen. EGO  
overheat relay

露点变送器  
Dew-point  
transducer

P=0.015kW  
IN=0.1A  
转鼓马达  
Rotor  
motor

干燥风车  
Drying  
blower

再生风车  
Regen.  
blower

再生电热  
Regen.  
heater

再生电热脱扣器  
Tripper for  
regenerating  
heater

干燥电热电源  
Drying  
heater  
power

再生热电偶  
Regen.  
thermocouple

电源相序保护模块  
Phase sequence  
protector

机型版本 Ver.B

						制图	版号	A	标题	SCD-40Ux2-80H	图号	比例	第 4 张
						设计	核准		控制电路图二	SCD-40Ux2-80H-CE-400V-A-4	标准	CE	共 10 张
						校对	核准		信易电热机械股份有限公司 Shini Plastics Technologies, Inc.	机器电压	3φ400V		
标记	更改前	更改后	更改人	日期	审核	日期	2024.05.20	机器频率		50Hz			

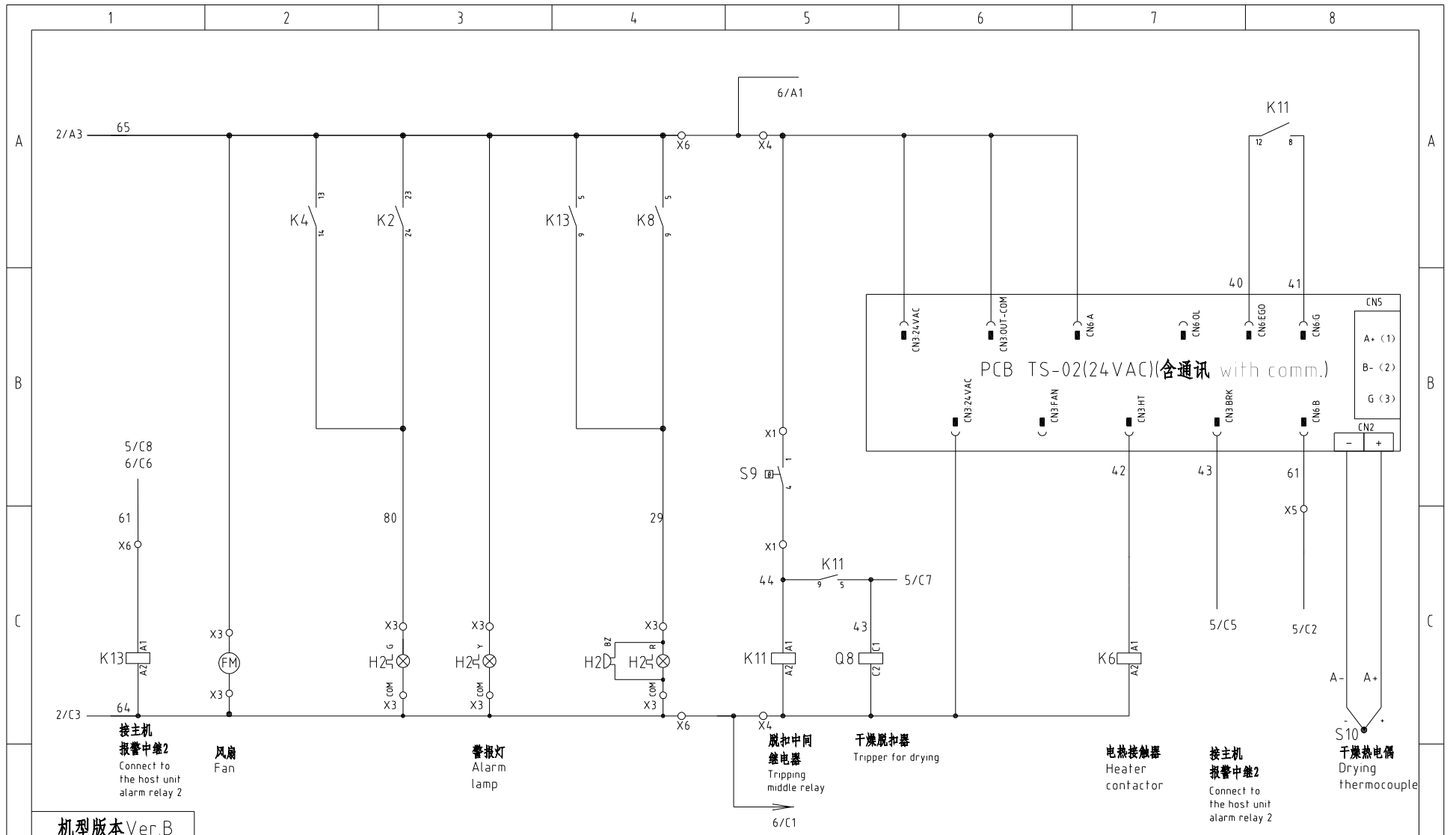

机型版本 Ver.B

						制图	版号	A
						设计	核准	
						校对	核准	
标记	更改前	更改后	更改人	日期	审核	日期	20240520	

标题 SCD-40U×2-80H  
控制电路图三

图号 SCD-40U×2-80H-CE-400V-A-5

**SHINI** 信易电热机械股份有限公司  
Shini Plastics Technologies, Inc.

比例	第 5 张
标准	CE
共 10 张	
机器电压	3φ400V
机器频率	50Hz

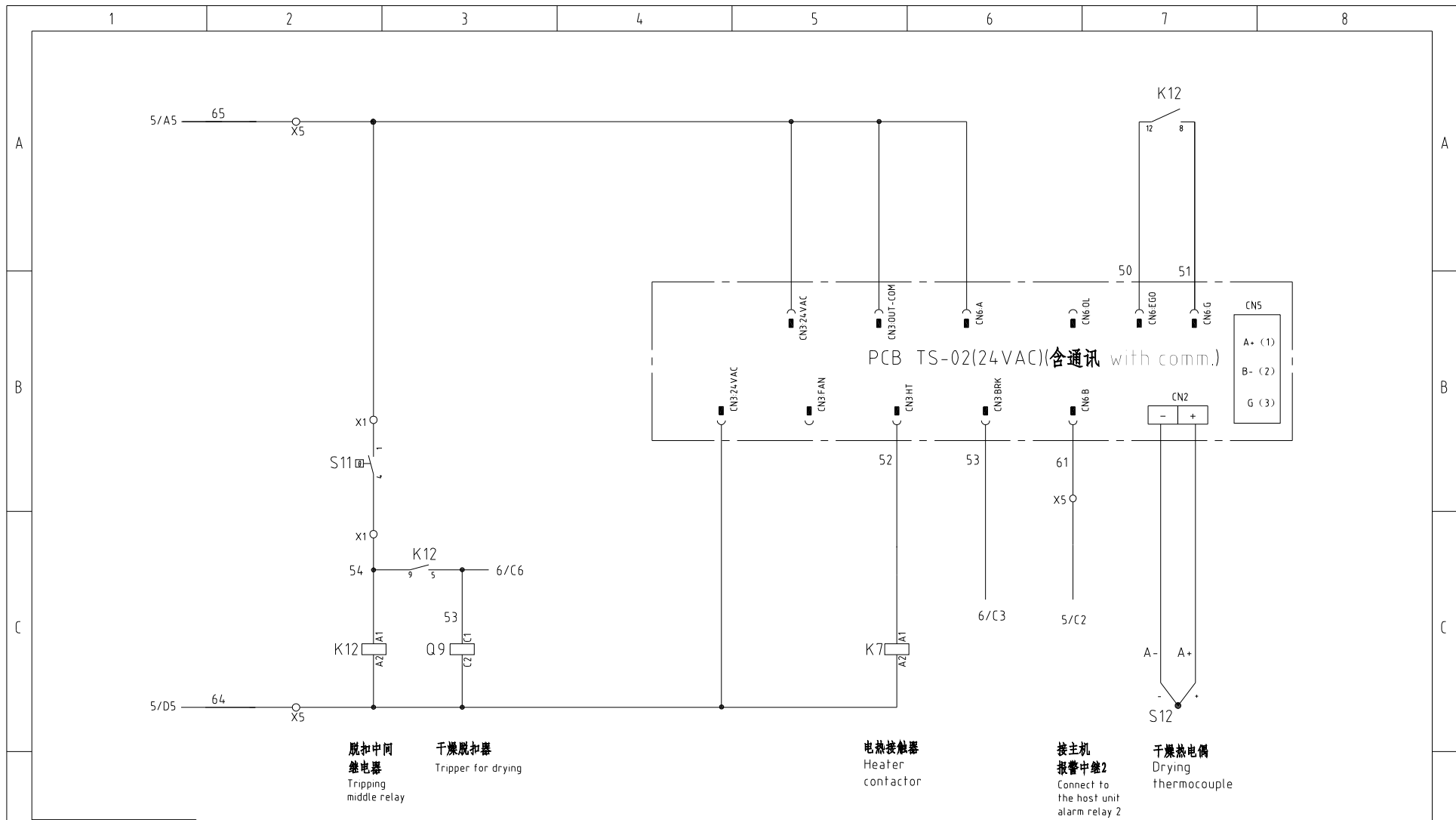

机型版本 Ver.B						制图		版号 A		标题 SCD-40U×2-80H		图号 SCD-40U×2-80H-CE-400V-A-6		比例		第 6 张	
						设计		核准		控制电路图四		标准 CE		共 10 张			
						校对		日期 20240520		SHINI 信易电热机械股份有限公司 Shini Plastics Technologies, Inc.		机器电压		3φ400V			
标记						更改前		更改后		更改人		日期		审核		机器频率 50Hz	

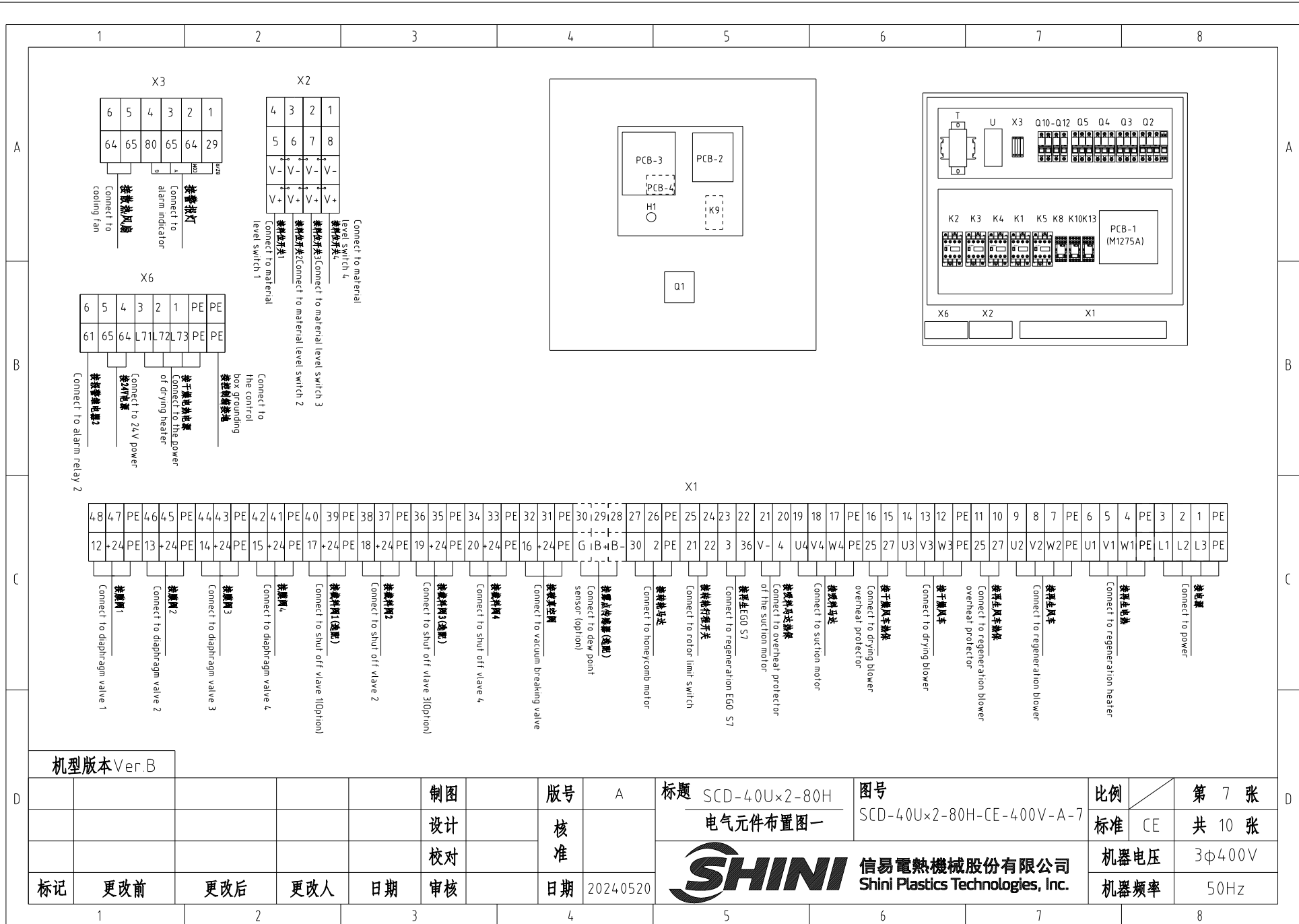

机型版本 Ver.B

					制图	版号	A	标题	SCD-40Ux2-80H 电气元件布置图一	图号	SCD-40Ux2-80H-CE-400V-A-7	比例	第 7 张
					设计	核准						标准	CE
					校对	核准						机器电压	3φ400V
标记	更改前	更改后	更改人	日期	审核	日期	2024.05.20	<b>SHINI</b>	信易电热机械股份有限公司 Shini Plastics Technologies, Inc.			机器频率	50Hz

1 2 3 4 5 6 7 8

A

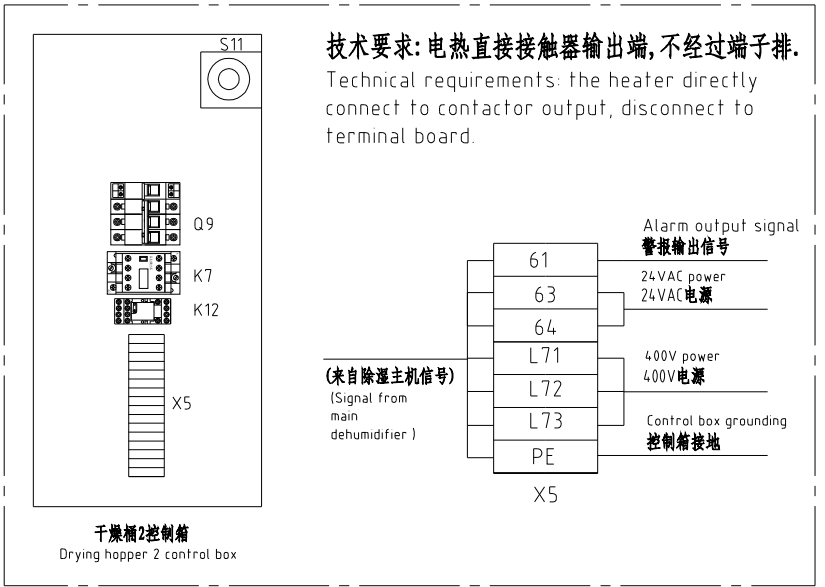
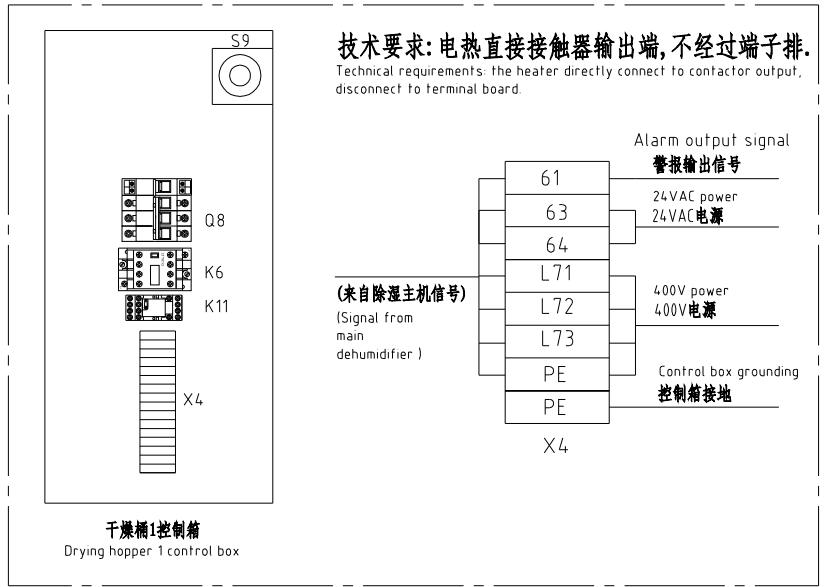

A

B

B

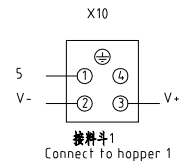

脚号 Subscript	功能 Function	描述 Description
1	5 (SEN)	接料位开关1 Connect to material level switch 1
2	GND	Connect to material level switch 1
3	24 V+	
4	----	----

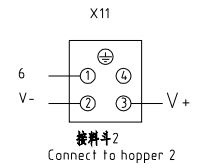

脚号 Subscript	功能 Function	描述 Description
1	6 (SEN)	接料位开关2 Connect to material level switch 2
2	GND	Connect to material level switch 2
3	24 V+	
4	----	----

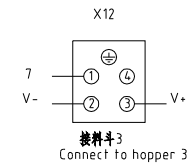

脚号 Subscript	功能 Function	描述 Description
1	7 (SEN)	接料位开关3 Connect to material level switch 3
2	GND	Connect to material level switch 3
3	24 V+	
4	----	----

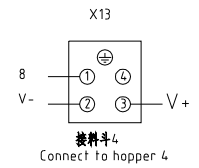

脚号 Subscript	功能 Function	描述 Description
1	8 (SEN)	接料位开关4 Connect to material level switch 4
2	GND	Connect to material level switch 4
3	24 V+	
4	----	----

C

C

机型版本 Ver.B

						制图	版本号	A	标题	SCD-40U×2-80H 电气元件布置图二	图号	SCD-40U×2-80H-CE-400V-A-8	比例	第 8 张
						设计	核准					标准	CE	共 10 张
						校对	核准					机器电压	3φ400V	
标记	更改前	更改后	更改人	日期	审核	日期	2024.05.20					机器频率	50Hz	



信易电热机械股份有限公司  
 Shini Plastics Technologies, Inc.

1 2 3 4 5 6 7 8

D

D



1		2		3		4		5		6		7		8							
序号/NO	符号/Symbol	名称/Name		制造商/Manufacturer		型号/Type		规格/Specification		单位/unit	数量/Number	物料编号/Material number		备注/Remark							
1	Q1	主电源开关 /Main power Switch		EATON		P1-32/EA/SVB 32A		32A		PCS	1	YE10323200000									
2	Q2 Q5 Q8 Q9	断路器 /Circuit breaker		TECO		BM-63C/3010S		10A		PCS	4	YE40301003000									
3		脱扣器 /Tripper		YIJIN		MX		110V~400V/50/60HZ		PCS	1	YE40023560000									
4		脱扣器 /Tripper		TECO		MX		24VAC		PCS	2	YE40024000000									
5	Q3 Q4	断路器 /Circuit breaker		TECO		BM-63C/3006S		6A		PCS	2	YE40300603000									
6	Q6 Q7	主电源开关 /Main power Switch		EATON		T0-2-1/EA/SVB/20A		20A		PCS	2	YE10021160000									
7	Q10	断路器/Circuit breakers		TECO		BM-63C		3A		PCS	1	YE40200203000									
8	Q11 Q12	断路器/Circuit breakers		TECO		BM-63C		3A		PCS	2	YE40100203000									
9	K1 K4	交流接触器/AC Contactors		SIEMENS		3RT6016-1AN21		9A 1NO 220V 50/60Hz		PCS	2	YE00601621000									
10	K2 K3	交流接触器/AC Contactors		SIEMENS		3RT6015-1AN21		7A 1NO 220V 50/60Hz		PCS	2	YE00601521000									
11		辅助触点/Auxiliary contacts		SIEMENS		3RH6911-1AA10		1AA10		PCS	1	YE00691110000									
12	K5	交流接触器/AC Contactors		SIEMENS		3RT6018-1AN21		16A NO 220V 50/60Hz		PCS	1	YE00601800000									
13	K6 K7	交流接触器/AC Contactors		SIEMENS		3RT6016-1AB01		9A 1NO 24V 50/60Hz		PCS	2	YE00601602500									
14	K8 K10	中间继电器 /Middle relay		Honeywell		DRM270730LT		230V 50/60Hz		PCS	2	YE03270700000									
15	K11 K12 K13	中间继电器 /Middle relay		Honeywell		GR-2C-AC24V+PGR-2C-E		24V 50/60Hz配座 base		PCS	3	YE03022400300									
16	K9	露点显示器/Dew-point meter		SHINI		Dewpoint Meter		220V 50/60Hz		PCS	1	YE85122000100		(3)							
17	S5	露点变送器/Dew-point transducer		VAISALA		DMT141		POWER=24VDC 4-20mA		PCS	1	YE90014100100		(1) (3)							
18	T	互感变压器 /Sensor Transformer		JIUXIN		IN=400V OUT=230V/24V		1000mA/80VA		PCS	1	YE70040008800									
19	U	直流电源 /DC Power		DELTA		PMT-24V35W2BA		---		PCS	1	YE70243500000									
20	PCB-1 (PCB-2)	微电脑控制板/PCB		HONGYUN		M1275		一对四 one-to-four		PCS	1	YE80127500000									
21	PCB-3	微电脑控制板/PCB		YUYUN		TU-01A+SA-RCS2		220VAC		PCS	1	YE80001100000									
22	PCB-4	微电脑控制板/PCB		YUYUN		TU-01B		-----		PCS	1	YE80001100100									
23	PCB-5 PCB-6	干燥机线路板/Dryer circuit board		YUYUN		TS-02(24VDC/AC)		24VAC		PCS	2	YE80022401200									
24	H1	蜂鸣器/Buzzer		HITPOINT		PK-27A/29EP(DC3-24V)		24VDC		PCS	1	YE84002700000		(1)							
25	H2	三色报警灯(红绿黄三色) 3-color alarm lamp (Red, green, yellow lights + base) 30*14*22mm		SHINI		优先级 Priority		24V 50/60Hz		PCS	1	BL90002401520		(1)							
机型版本 Ver.B		注: (1)表示非电控箱内材料 (2)表示选配截料阀 (3)表示选配露点 Notes: (1)Means it's not the material inside the control box. (2)Optional shut off valve. (3)optional dewpoint.																			
				制图		版号		A		标题		图号		比例		第 9 张					
				设计		核		电器明细		SCD-40U气元件明细表/400V/50HZ (Ver. B)		SCD-40U气元件明细表/400V/50HZ (Ver. B)		标准		CE 共 10 张					
				校对		准								机器电压		3φ400V					
标记		更改前		更改后		更改人		日期		审核		日期		20240520		SHINI 信易电热机械股份有限公司 Shini Plastics Technologies, Inc.		机器频率		50Hz	
1		2		3		4		5		6		7		8							

1		2		3		4		5		6		7		8		
序号/NO	符号/Symbol	名称/Name		制造商/Manufacturer		型号/Type		规格/Specification		单位/unit	数量/Number	物料编号/Material number		备注/Remark		
A	26	X1-X6	端子排/Terminal Board		Honeywell		SK4		4mm <sup>2</sup>		PCS	21	YE60000403200			
	27		端子排/Terminal Board		Honeywell		GK4		4mm <sup>2</sup> PE		PCS	5	YE60000403500			
	28		端子排/Terminal Board		Honeywell		SK2.5		2.5mm <sup>2</sup>		PCS	4.5	YE60002503200			
	29		端子排/Terminal Board		Honeywell		GK2.5		2.5mm <sup>2</sup> PE		PCS	15	YE60002503400			
	30		端子排/Terminal board		HONEYWELL		三層端子 Three-layer spring terminal SK2.5-TL		10A 250V		PCS	4	YE60002503600			
	31		端子排/Terminal board		HONEYWELL		SK-2.5TL桥接件 bridgeware		10A 250V		PCS	0.7	YE60001003600			
	32		端子排/Terminal Board		Honeywell		GK6		6mm <sup>2</sup>		PCS	3	YE60000603200			
B	33		端子排/Terminal Board		Honeywell		GK6PE		6mm <sup>2</sup> PE		PCS	1	YE60000603500			
	34		终端固定件E/GK系列 Terminal fittings E/GK series		Honeywell		E		GK		PCS	5	YE60000003900			
	--	Y1~Y7	电磁阀/Solenoid valve		----		SPDV-38		24VDC			7	----		(1)	
	--	Y8 Y9	电磁阀/Solenoid valve		----		----		24VDC			2	----		(1) (2)	
	--	X10,X11,X12,X13	重载接插件/Heavy-duty plug-in		HARTING		HDC-HA-004.1		4P 10A			4	----		(1)	
	--	S6	微动开关/Micro switch		----		YBLXW-5/11G2		----			1	----		(1)	
	--	S7 S9 S11	组合体EG0/FG0 assembly		SHINI		(115-320℃ 55.13262.160)		----			3	----		(1)	
C	--	S8 S10 S12	热电偶/Thermocouple		SHINI		SD-30H/120H(2.5M)MY07		----			3	----		(1)	
	--	M1	再生风机/Regenerative blower		SHINI		RB205		0.2KW 380-415V 50Hz			1	----		(1)	
	--	M2	干燥风机/Drying blower		SHINI		RB310		1.5KW 380-415V 50Hz			1	----		(1)	
	--	M3	吸料风机/Suction blower		SHINI		RB420		1.5KW 380-415V 50Hz			1	----		(1)	
	--	M4	减速马达/gear motor		SHINI		3GN-10XK/3GN-60K/3IK15GN-A-T		1Φ220V			1	----		(1)	
	--	EH1	电热/Heater		SHINI		4KW 3Φ230V/400V		SD-40H-D-03-04(0版 Ver. 0)			1	----		(1)	
	--	EH2 EH3	电热/Heater		SHINI		-----		400V 50Hz 6KW			2	----		(1)	
--	FM	排气扇/Exhaust fan		----		12×12CM/24V/50/60HZ		配塑胶网 With plastic net			1	----		(1)		
<b>机型版本 Ver.B</b> 注: (1)表示非电控箱内材料 (2)表示选配截料阀 (3)表示选配露点    Notes: (1)Means it 's not the material inside the control box. (2)Optional shut off valve. (3)optional dewpoint.																
D	标记		更改前	更改后	更改人	日期	审核	日期	2024.05.20	 <b>信易電熱機械股份有限公司</b> <b>Shini Plastics Technologies, Inc.</b>		比例		第 10 张		
												标题 SCD-40U×2-80H 电气元件明细表二		图号 SCD-40U×2-80H-CE-400V-A-10		共 10 张
													标准 CE			
													机器电压		3φ400V	
												机器频率		50Hz		

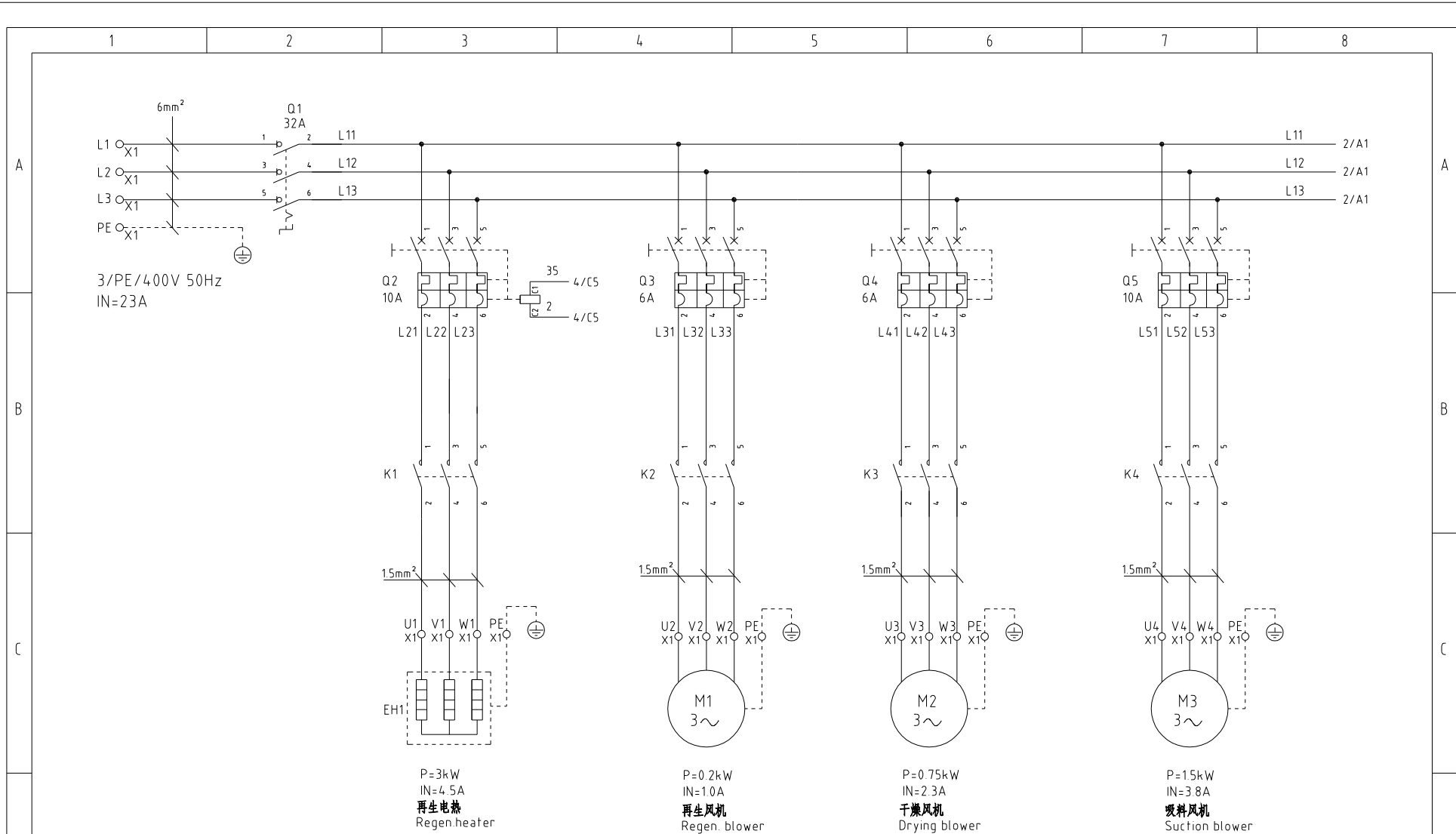

机型版本 Ver.B

				制图		版号 A		标题 SCD-80U×2/80H 主电路图一		图号 SCD-80U×2/80H-CE-400V-A-1		比例		第 1 张	
				设计		核准				标准 CE		共 10 张			
				校对		日期 2024.05.24		 <b>信易電熱機械股份有限公司</b> <b>Shini Plastics Technologies, Inc.</b>		机器电压		3φ400V			
标记		更改前		更改后		更改人				日期		机器频率		50Hz	

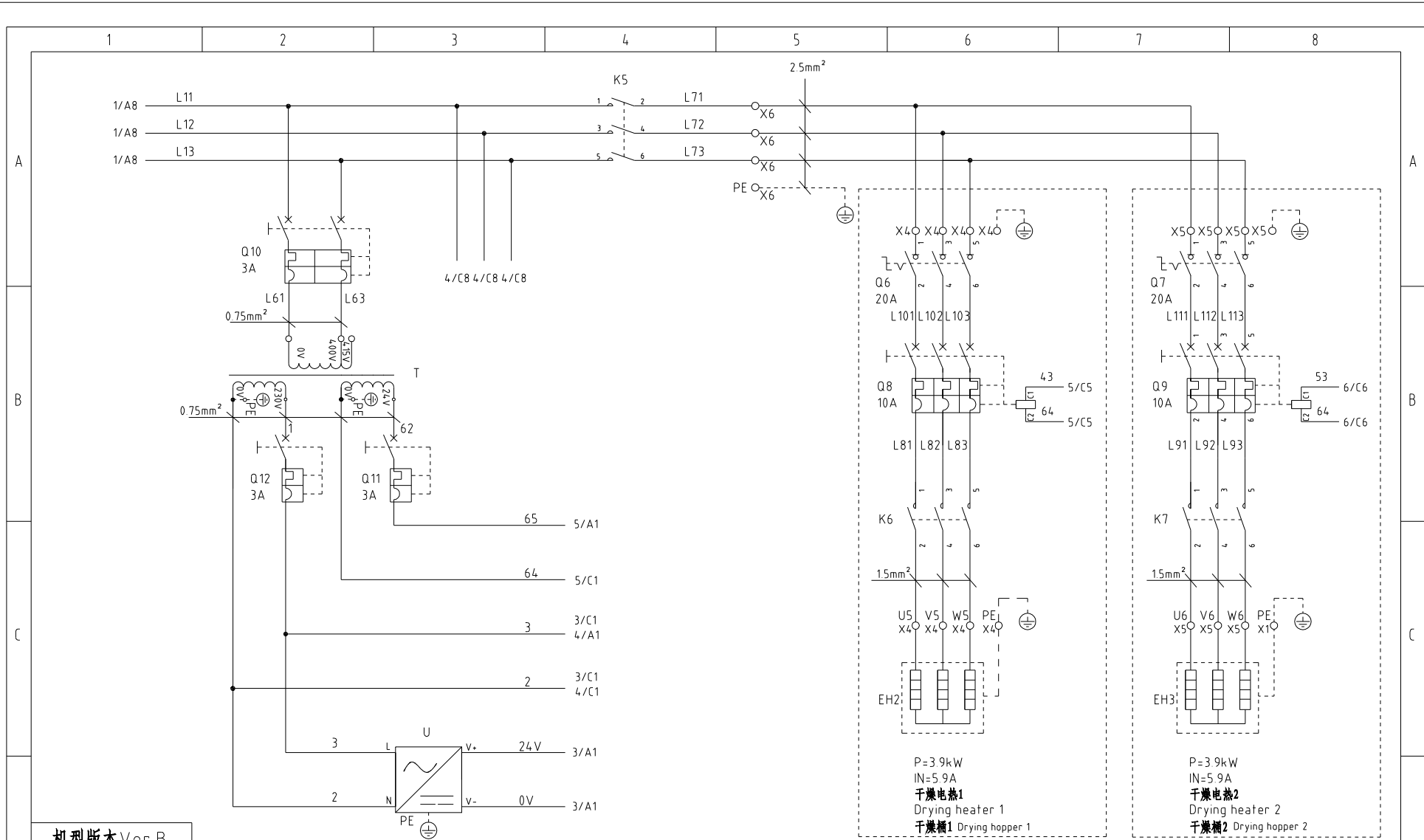

P=3.9kW  
IN=5.9A  
干燥电热1  
Drying heater 1  
干燥桶1 Drying hopper 1

P=3.9kW  
IN=5.9A  
干燥电热2  
Drying heater 2  
干燥桶2 Drying hopper 2

机型版本 Ver.B

制图						版号	A	标题	SCD-80U×2/80H	图号	SCD-80U×2/80H-CE-400V-A-2	比例	第 2 张
设计						核准		主电路图二		标准	CE	共 10 张	
校对						核准				机器电压	3φ400V		
标记	更改前	更改后	更改人	日期	审核	日期	2024.05.24	<b>SHINI</b> 信易电热机械股份有限公司 Shini Plastics Technologies, Inc.		机器频率	50Hz		

1 2 3 4 5 6 7 8

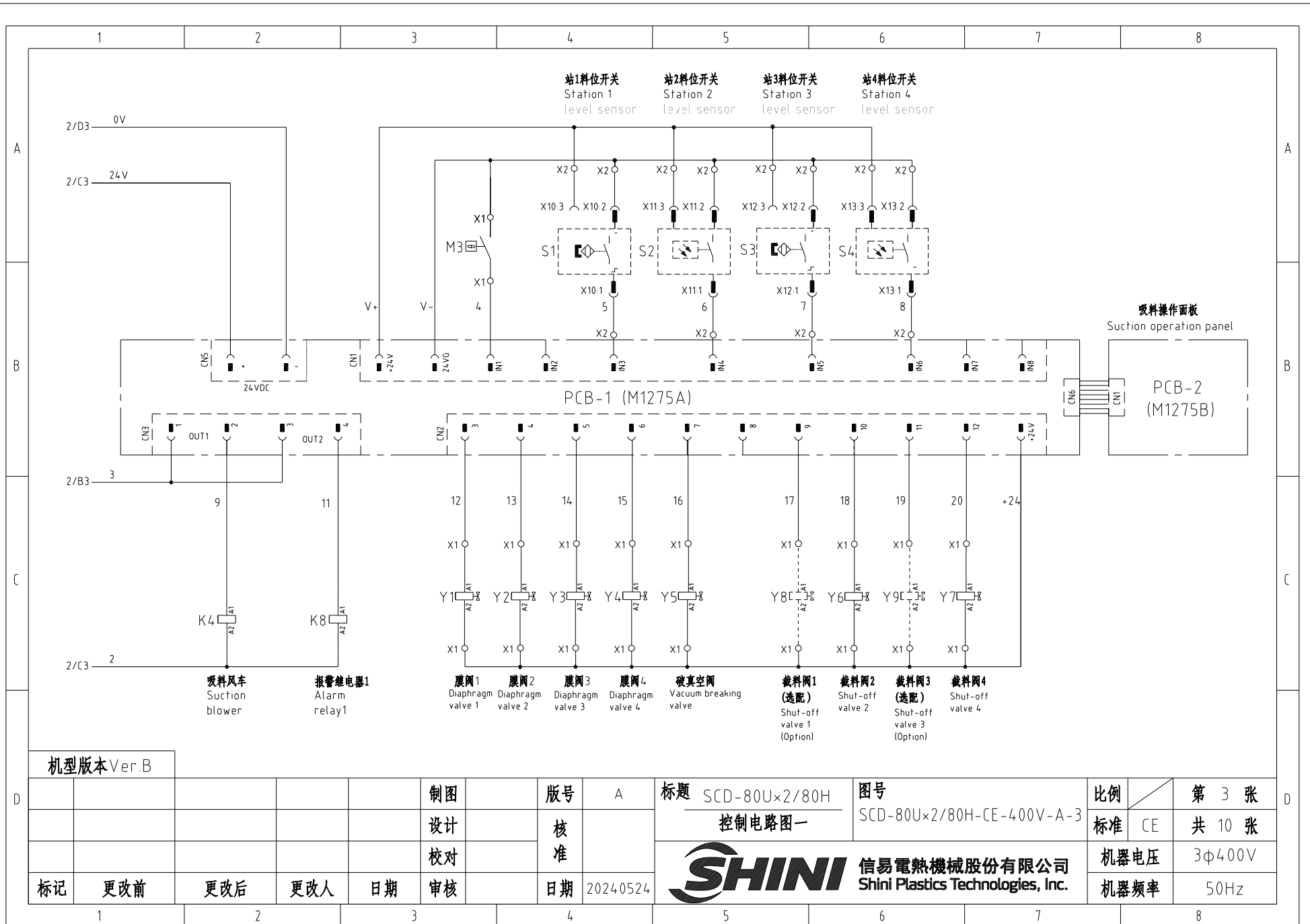

机型版本 Ver.B

					制图	版号	A	标题	SCD-80U×2/80H	图号	SCD-80U×2/80H-CE-400V-A-3	比例	第 3 张
					设计	核准		控制电路图一		标准	CE	共 10 张	
					校对	核准		 <b>信易电热机械股份有限公司</b> <b>Shini Plastics Technologies, Inc.</b>	机器电压	3φ400V			
标记	更改前	更改后	更改人	日期	审核	日期	2024.05.24		机器频率	50Hz			

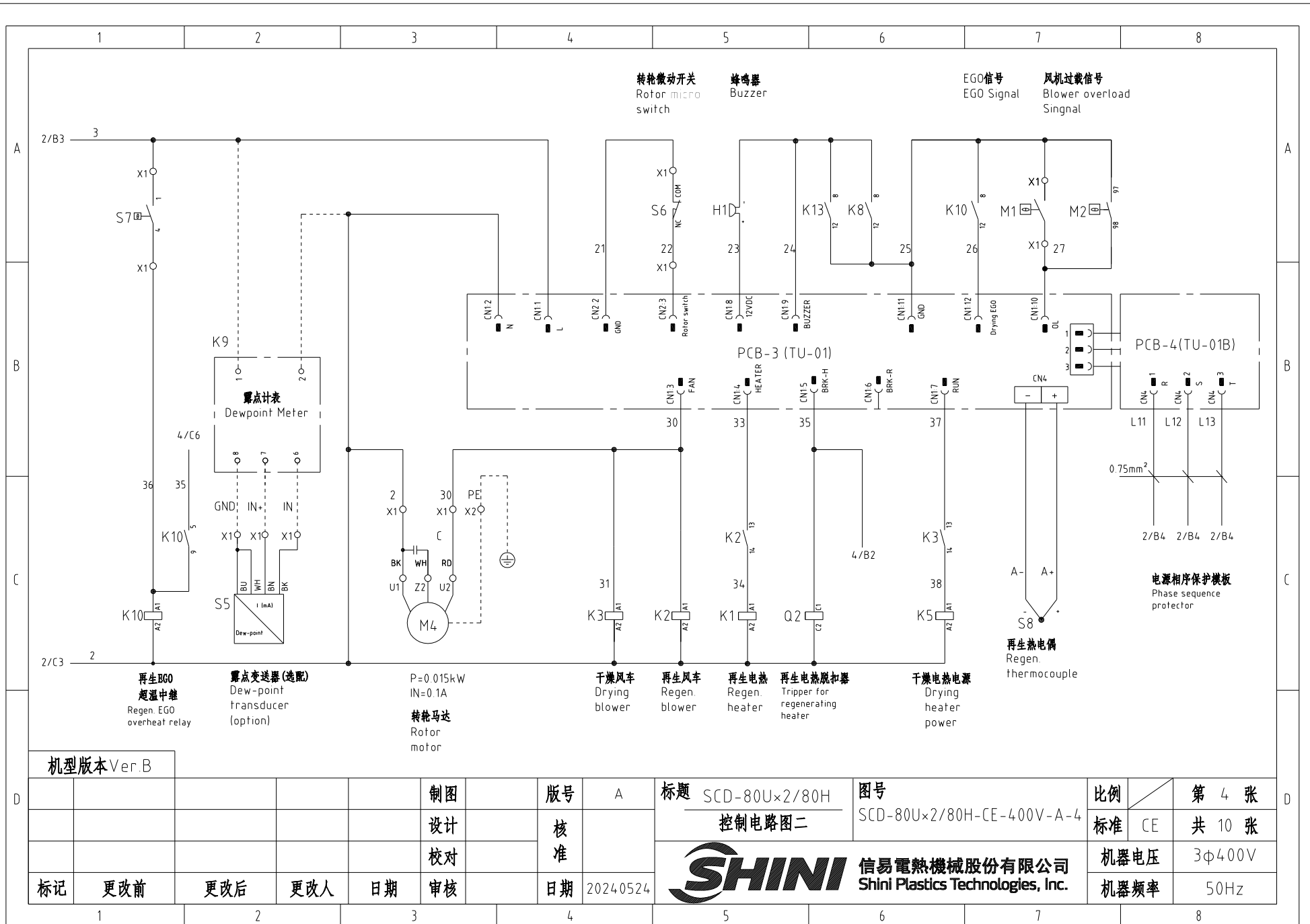

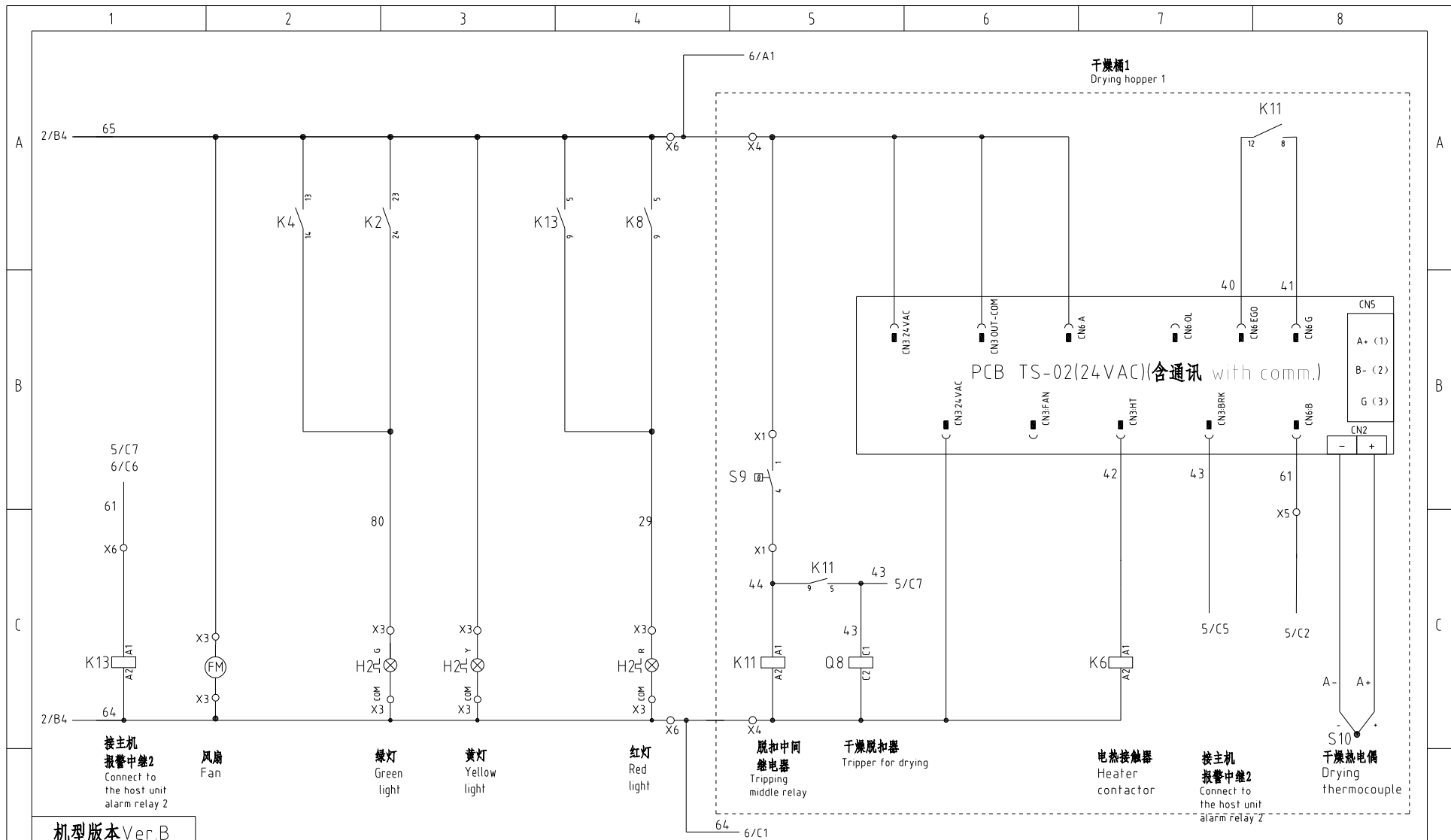

机型版本 Ver.B

制图	版号	A	标题	SCD-80U×2/80H
设计	核准		图号	SCD-80U×2/80H-CE-400V-A-5
校对	核准		比例	第 5 张
标记	更改前	更改后	更改人	日期
	1	2	3	4
	1	2	3	4
	1	2	3	4
	1	2	3	4

比例	第 5 张
标准	CE
机器电压	3φ400V
机器频率	50Hz



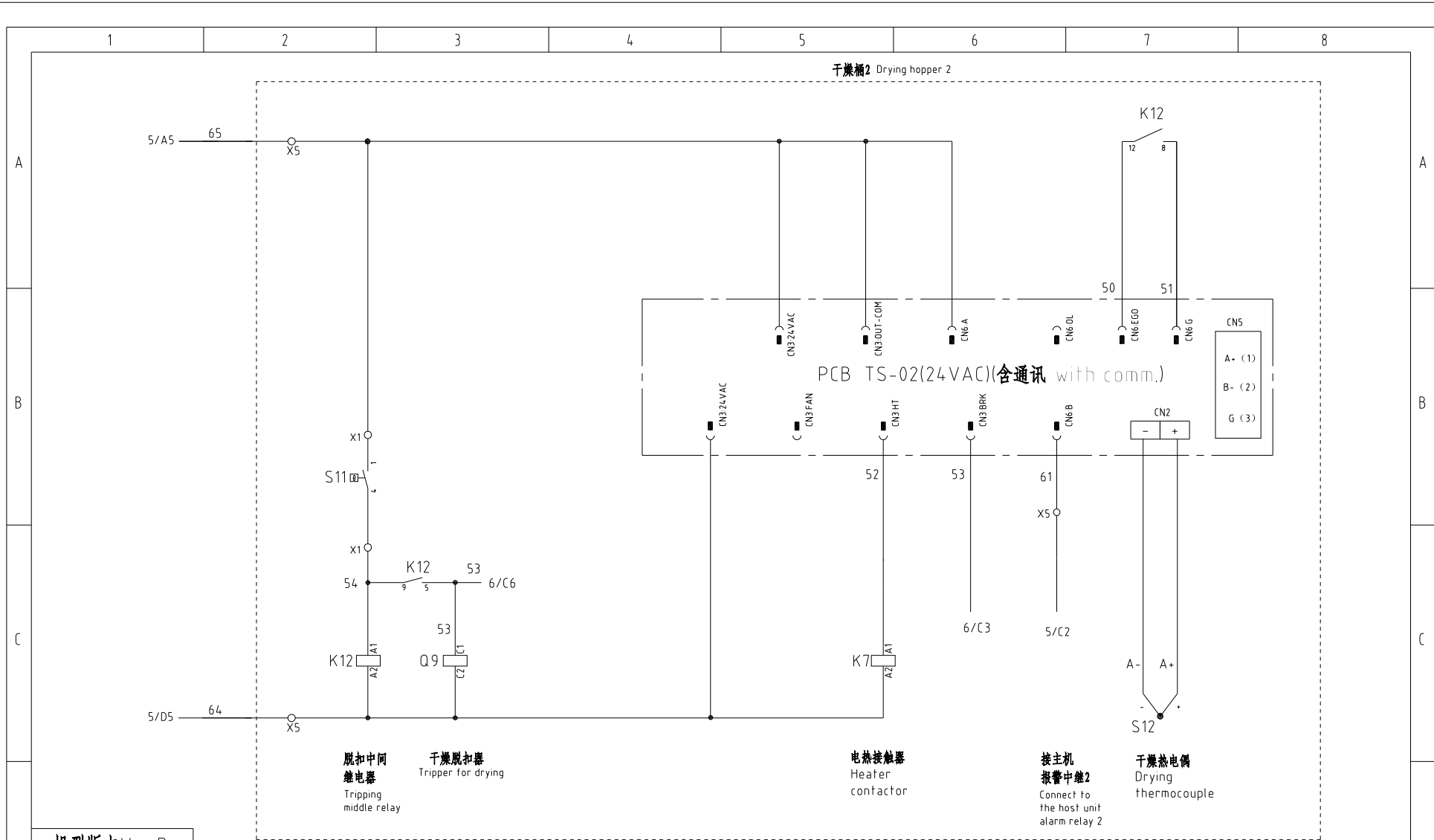

机型版本 Ver.B

				制图		版号 A		标题 SCD-80U×2/80H		图号		比例		第 6 张	
				设计		核准		控制电路图四		SCD-80U×2/80H-CE-400V-A-6		标准 CE		共 10 张	
				校对		核准		<b>信易电热机械股份有限公司</b> <b>Shini Plastics Technologies, Inc.</b>		机器电压		3φ400V			
标记		更改前		更改后		更改人				日期		20240524		机器频率	





1 2 3 4 5 6 7 8

A

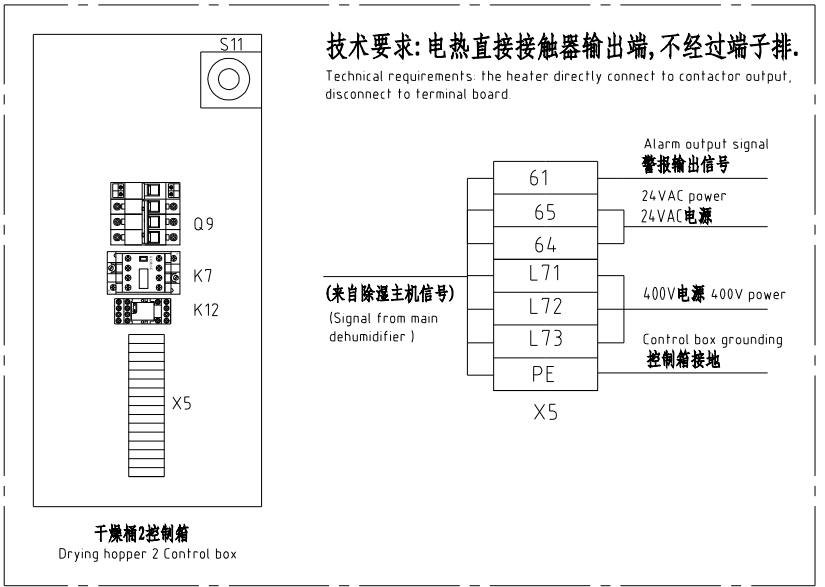
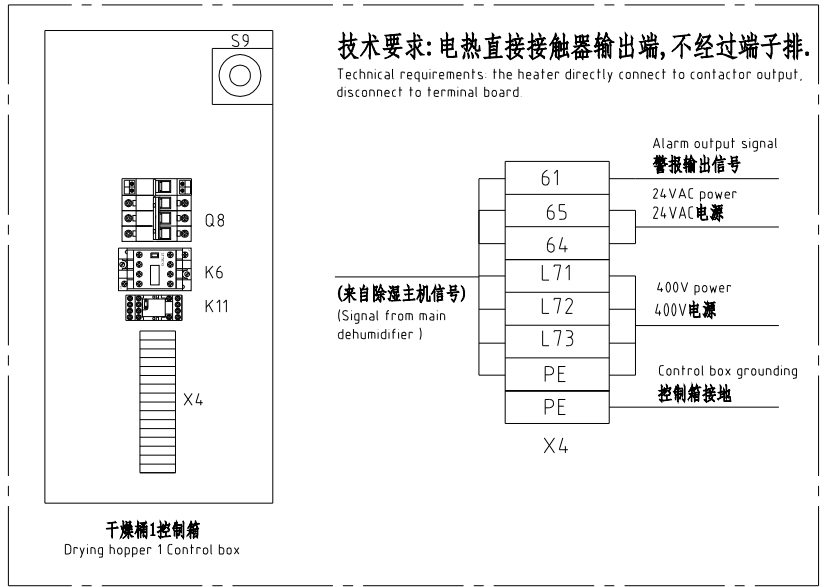

A

B

B

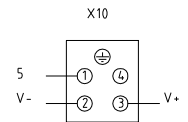

接料斗1  
 Connect to hopper 1

序号 Subscript	功能 Function	描述 Description
1	料位信号(SENS) Material level signal (SENS)	接料位开关1 Connect to material level switch 1
2	GND	
3	24V+	
4	----	----

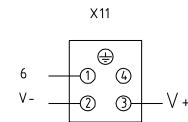

接料斗2  
 Connect to hopper 2

序号 Subscript	功能 Function	描述 Description
1	料位信号(SENS) Material level signal (SENS)	接料位开关2 Connect to material level switch 2
2	GND	
3	24V+	
4	----	----

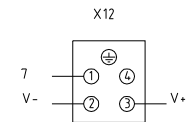

接料斗3  
 Connect to hopper 3

序号 Subscript	功能 Function	描述 Description
1	料位信号(SENS) Material level signal (SENS)	接料位开关3 Connect to material level switch 3
2	GND	
3	24V+	
4	----	----

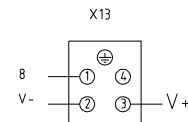

接料斗4  
 Connect to hopper 4

序号 Subscript	功能 Function	描述 Description
1	料位信号(SENS) Material level signal (SENS)	接料位开关4 Connect to material level switch 4
2	GND	
3	24V+	
4	----	----

C

C

机型版本 Ver.B

						制图	版号	A	标题	SCD-80U×2/80H 电气元件布置图二	图号	SCD-80U×2/80H-CE-400V-A-8	比例	第 8 张
						设计	核准				标准	CE		共 10 张
						校对	核准				机器电压	3φ400V		
标记	更改前	更改后	更改人	日期	审核	日期	2024.05.24			<b>SHINI</b>	信易电热机械股份有限公司 Shini Plastics Technologies, Inc.	机器频率	50Hz	

1 2 3 4 5 6 7 8

D

D

1		2		3		4		5		6		7		8			
序号/NO	符号/Symbol	名称/Name		制造商/Manufacturer		型号/Type		规格/Specification		单位/unit	数量/Number	物料编号/Material number		备注/Remark			
1	Q1	主电源开关 /Main power Switch		EATON		P1-32/EA/SVB 32A		32A		PCS	1	YE10323200000					
2	Q2 Q5 Q8 Q9	断路器 /Circuit breaker		TECO		BM-63C/3010S		10A		PCS	4	YE40301003000					
3		脱扣器/Trippler		YIJIN		MX		110V~400V/50/60HZ		PCS	1	YE40023560000					
4		脱扣器/Trippler		YIJIN		MX		24VAC		PCS	2	YE40024000000					
5	Q3 Q4	断路器 /Circuit breaker		TECO		BM-63C/3006S		6A		PCS	2	YE40300603000					
6	Q6 Q7	主电源开关 /Main power Switch		EATON		T0-2-1/EA/SVB/20A		20A		PCS	2	YE10021160000					
7	Q10	断路器/Circuit breakers		TECO		BM-63C		3A		PCS	1	YE40200203000					
8	Q11 Q12	断路器/Circuit breakers		TECO		BM-63C		3A		PCS	2	YE40100203000					
9	K4	交流接触器/AC Contactors		SIEMENS		3RT6016-1AN21		9A 1NO 220V 50/60Hz		PCS	1	YE00601621000					
10	K1-K3	交流接触器/AC Contactors		SIEMENS		3RT6015-1AN21		7A 1NO 220V 50/60Hz		PCS	3	YE00601521000					
11		辅助触点/Auxiliary contacts		SIEMENS		3RH6911-1AA10		1AA10		PCS	1	YE00691110000					
12	K5	交流接触器/AC Contactors		SIEMENS		3RT6018-1AN21		16A NO 220V 50/60Hz		PCS	1	YE00601800000					
13	K6 K7	交流接触器/AC Contactors		SIEMENS		3RT6016-1AB01		9A 1NO 24V 50/60Hz		PCS	2	YE00601602500					
14	K8 K10	中间继电器 /Middle relay		Honeywell		DRM270730LT		230V 50/60Hz		PCS	2	YE03270700000					
15	K11 K12 K13	中间继电器 /Middle relay		Honeywell		GR-2C-AC24V+PGR-2C-E		24V 50/60Hz配座 base		PCS	3	YE03022400300					
16	K9	露点显示器/Dew-point displayer		SHINI		Dewpoint Meter		220V 50/60Hz		PCS	1	YE85122000100		(3)			
17	S5	露点变送器/Dew-point transducer		VAISALA		DMT141		POWER=24VDC 4-20mA		PCS	1	YE90014100100		(1) (3)			
18	T	互感变压器 /Sensor Transformer		JIUXIN		IN=400V OUT=230V/24V		1000mA/80VA		PCS	1	YE70040008800					
19	U	直流电源 /DC Power		DELTA		PMT-24V35W2BA		---		PCS	1	YE70243500000					
20	PCB-1 (PCB-2)	微电脑控制板/Microprocessor control board		HONGYUN		M1275		一对四 one-to-four		PCS	1	YE80127500000					
21	PCB-3	微电脑控制板/Microprocessor control board		YUYUN		TU-01A+SA-RCS2		220VAC		PCS	1	YE80001100000					
22	PCB-4	微电脑控制板/Microprocessor control board		YUYUN		TU-01B		-----		PCS	1	YE80001100100					
23	PCB-5 PCB-6	干燥机线路板/Dryer circuit board		YUYUN		TS-02(24VDC/AC)		24VAC		PCS	2	YE80022401200					
24	H1	蜂鸣器/Buzzer		HITPOINT		PK-27A/29EP(DC3-24V)		24VDC		PCS	1	YE84002700000		(1)			
25	X1-X6	端子排/Terminal Board		Honeywell		SK6		6mm <sup>2</sup>		PCS	6	YE60000603200					
机型版本 Ver.B		注: (1)表示非电控箱内材料 (2)表示选配截料阀 (3)表示选配露点 Notes: (1)Means it 's not the material inside the control box. (2)Optional shut off valve. (3)optional dewpoint.															
				制图		版号		A		标题		图号		比例		第 9 张	
				设计		核				SCD-80U×2/80H		SCD-80U×2/80H-CE-400V-A-9		标准		CE	
				校对		准				电气元件明细表一				机器电压		3φ400V	
标记		更改前		更改后		更改人		日期		审核		日期		20240524		SHINI 信易電熱機械股份有限公司 Shini Plastics Technologies, Inc.	
1		2		3		4		5		6		7		8			

1	2	3	4	5	6	7	8		
序号/NO	符号/Symbol	名称/Name	制造商/Manufacturer	型号/Type	规格/Specification	单位/unit	数量/Number	物料编号/Material number	备注/Remark
26		端子排/Terminal Board	Honeywell	GK6	6mm <sup>2</sup> PE	PCS	2	YE60000603500	
27		端子排/Terminal Board	Honeywell	SK4	4mm <sup>2</sup>	PCS	18	YE60000403200	
28		端子排/Terminal Board	Honeywell	GK4	4mm <sup>2</sup> PE	PCS	4	YE60000403500	
29		端子排/Terminal Board	Honeywell	SK2.5	2.5mm <sup>2</sup>	PCS	45	YE60002503200	
30		端子排/Terminal Board	Honeywell	GK2.5	2.5mm <sup>2</sup> PE	PCS	15	YE60002503400	
31		端子排/Terminal board	HONEYWELL	三层端子 Three-layer spring terminal SK2.5-TL	10A 250V	PCS	4	YE60002503600	
32		端子排/Terminal board	HONEYWELL	SK-2.5TL桥接件 bridgeware	10A 250V	PCS	0.7	YE60001003600	
33		终端固定件E/GK系列 Terminal fittings E/GK series	Honeywell	E	GK	PCS	5	YE60000003900	
34	H2	三色报警灯(红绿黄三色)三色报警灯 (red, green, yellow lights + buzzer) SHT-AL02N	SHINI	优先级 Priority	24V 50/60Hz	PCS	1	BL90002401520	(1)
--	Y1-Y7	电磁阀/Solenoid valve	----	SPDV-38	24VDC		7	----	(1)
--	Y8 Y9	电磁阀/Solenoid valve	----	----	24VDC		2	----	(1) (2)
--	X10,X11,X12,X13	重载接插件/Heavy-duty plug-in	HARTING	HDC-HA-004.1	4P 10A		4	----	(1)
--	S6	微动开关/Micro switch	----	YBLXW-5/11G2	----		1	----	(1)
--	S7 S9 S11	组合体FG0/FG0 assembly	SHINI	(115-320°C 55.13262.160)	----		3	----	(1)
--	S8 S10 S12	热电偶/Thermocouple	SHINI	SD-30H/120H(2.5M)MY07	----		3	----	(1)
--	M1	再生风机/Regen. blower	SHINI	2HB110H06	0.2KW 380-415V 50Hz		1	----	(1)
--	M2	干燥风机/Drying blower	SHINI	RB310	0.75KW 380-415V 50Hz		1	----	(1)
--	M3	吸料风机/Suction blower	SHINI	RB4.20	1.5KW 380-415V 50Hz		1	----	(1)
--	M4	减速马达/Gear motor	SHINI	3GN-10XK/3GN-60K/3K15GN-A-T	10220V		1	----	(1)
--	EH1	电热/Heater	SHINI	4KW 30230V/400V	D-40H-D-03-04(Ver.0)		1	----	(1)
--	EH2 EH3	电热/Heater	SHINI	----	400V 50Hz 6KW		2	----	(1)
--	FM	排气扇/Exhaust fan	----	12x12CM/240V/50/60HZ	配塑胶网 With plastic net		1	----	(1)

Notes: (1)Means it's not the material inside the control box. (2)Optional shut off valve. (3)optional dewpoint.

机型版本 Ver.B

注: (1)表示非电控箱内材料 (2)表示选配材料 (3)表示选配露点

制图		版号		A		标题		SCD-80U×2/80H		图号		比例		第 10 张	
设计		核				电气元件明细表二		SCD-80U×2/80H-CE-400V-A-10		标准		CE		共 10 张	
校对		准				 <b>信易电热机械股份有限公司</b> <b>Shini Plastics Technologies, Inc.</b>		机器电压		3φ400V					
标记		日期		2024.05.24				机器频率		50Hz					
1	更改前	更改后	更改人	日期	审核	日期	2024.05.24	1	更改前	更改后	更改人	日期	2024.05.24	1	更改前

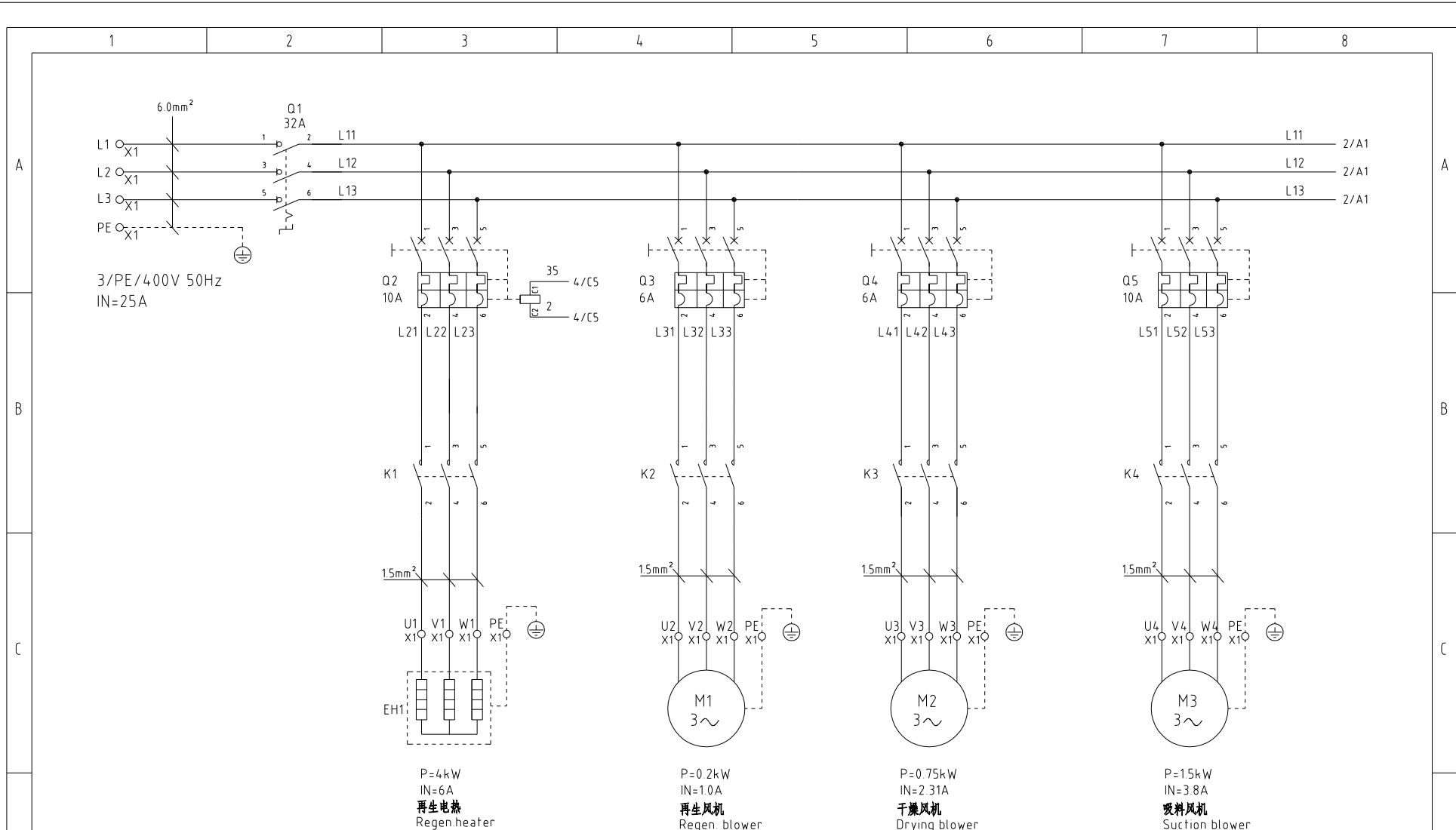

机型版本 Ver.B

			制图	版号	A	标题	SCD-120Ux2-120H 主电路图一	图号	SCD-120Ux2-120H-CE-400V-A-1	比例	第 1 张
			设计	核准						标准	共 10 张
			校对	核准						机器电压	3φ400V
标记	更改前	更改后	更改人	日期	审核	日期	2024.06.04	 <b>信易電熱機械股份有限公司</b> <b>Shini Plastics Technologies, Inc.</b>		机器频率	50Hz

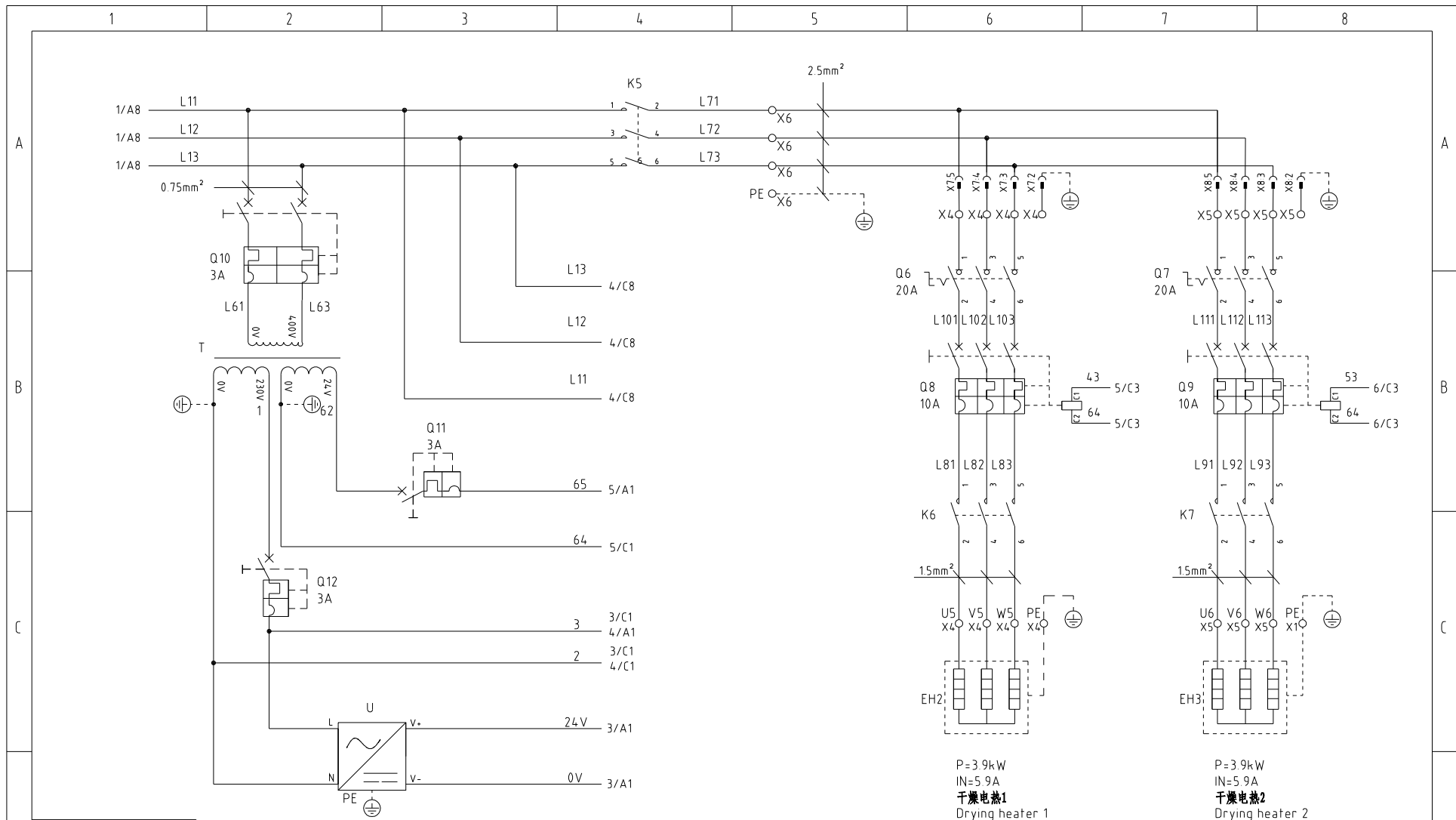

机型版本 Ver. B

						制图	版号	A	标题	SCD-120U×2-120H	图号	比例	第 2 张	
						设计	核准		主电路图二		SCD-120U×2-120H-CE-400V-A-2	标准	CE	共 10 张
						校对	核准		 <b>信易电热机械股份有限公司</b> <b>Shini Plastics Technologies, Inc.</b>		机器电压	3φ400V		
标记	更改前	更改后	更改人	日期	审核	日期	2024.06.04	机器频率			50Hz			

1 2 3 4 5 6 7 8

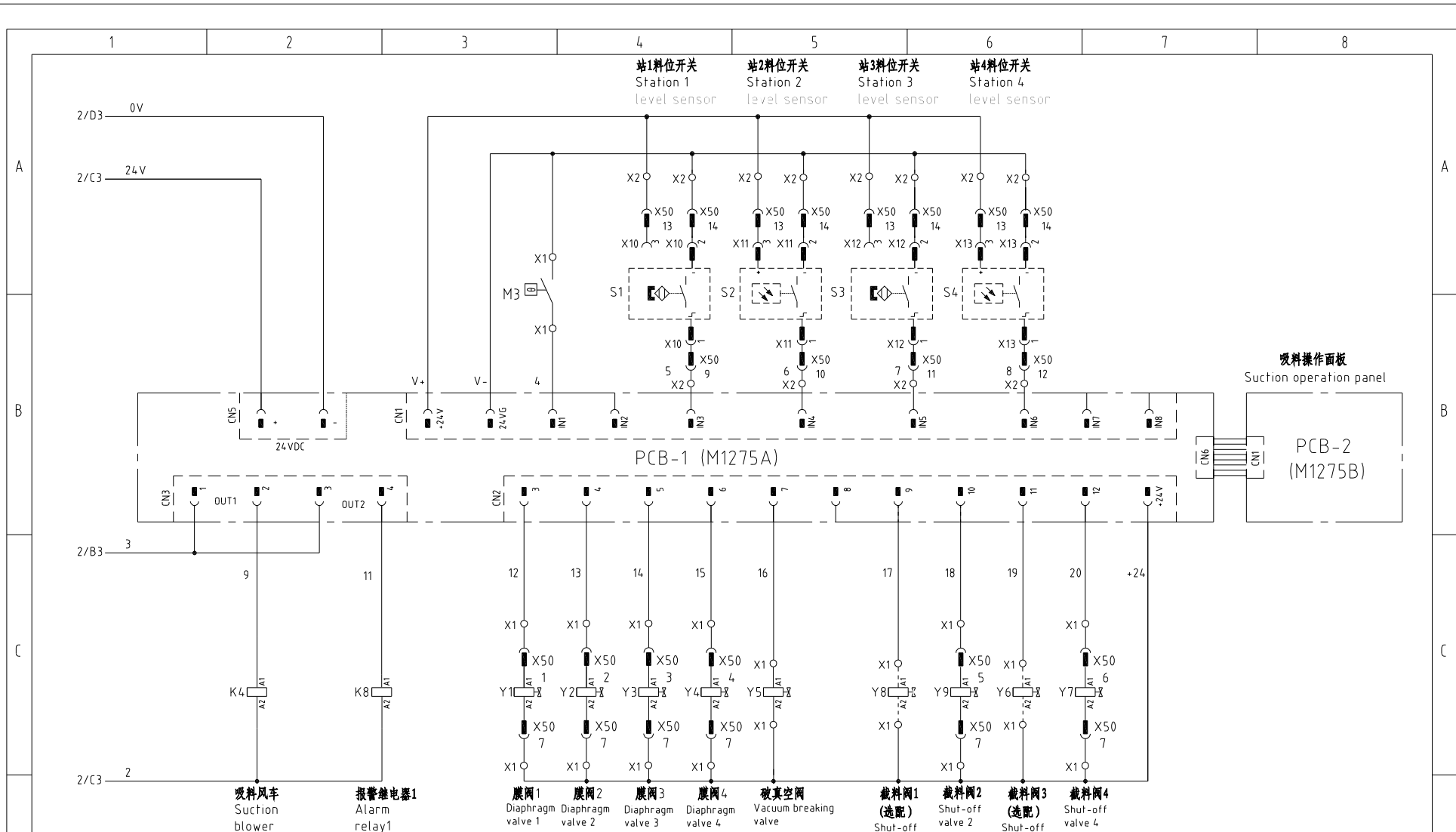

机型版本 Ver.B

					制图	版号	A	标题	SCD-120Ux2-120H	图号	SCD-120Ux2-120H-CE-400V-A-3	比例	第 3 张	
					设计	核准		控制电路图一				标准	CE	共 10 张
					校对	核准		 信易電熱機械股份有限公司 Shini Plastics Technologies, Inc.				机器电压	3φ400V	
标记	更改前	更改后	更改人	日期	审核	日期	2024.06.04						机器频率	50Hz

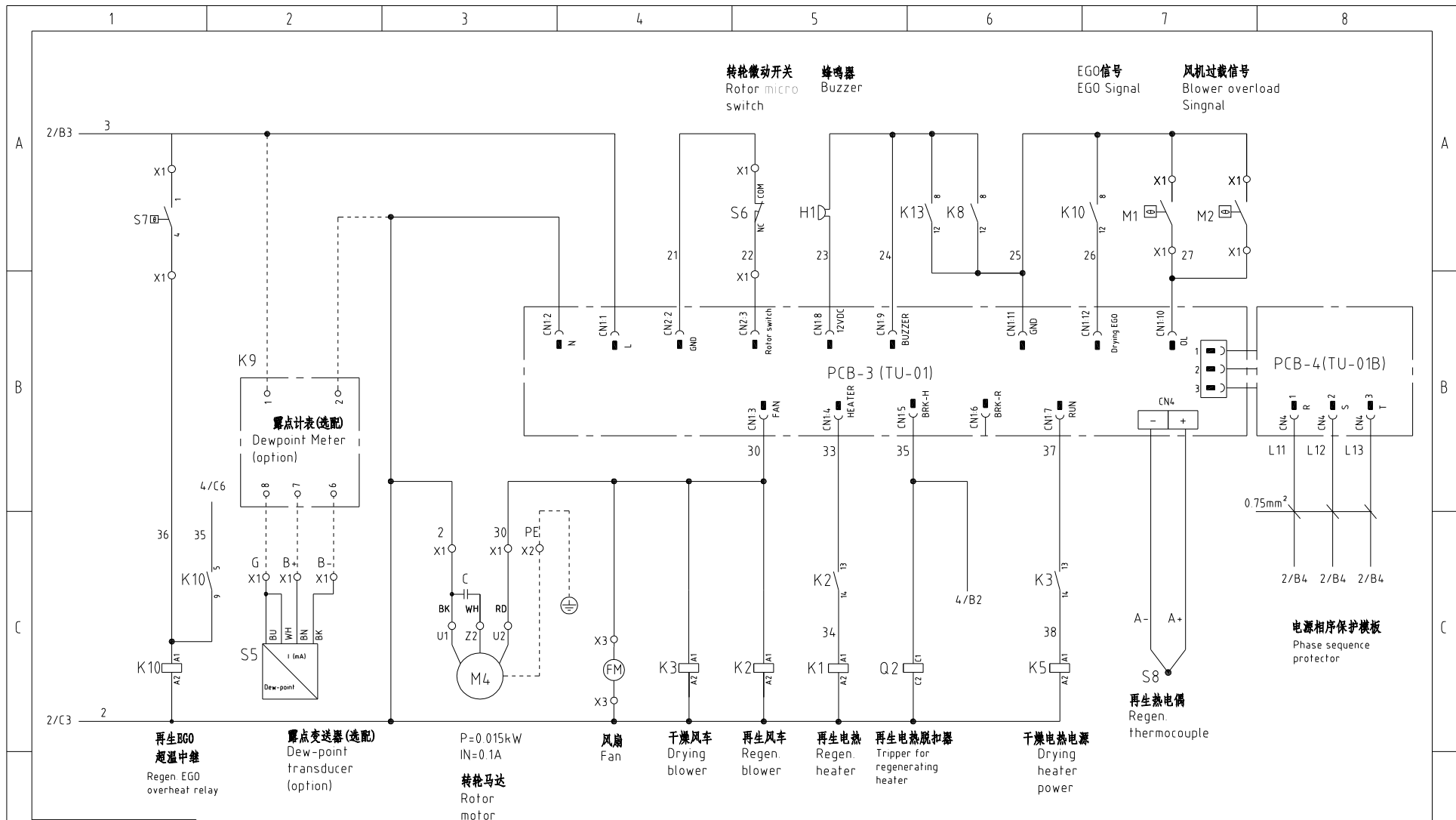

机型版本 Ver. B

						制图	版号	A	标题	SCD-120U×2-120H	图号	SCD-120U×2-120H-CE-400V-A-4	比例	第 4 张
						设计	核准		控制电路图二				标准	CE
						校对	核准						机器电压	3φ400V
标记	更改前	更改后	更改人	日期	审核	日期	2024.06.04						机器频率	50Hz



信易电热机械股份有限公司  
Shini Plastics Technologies, Inc.



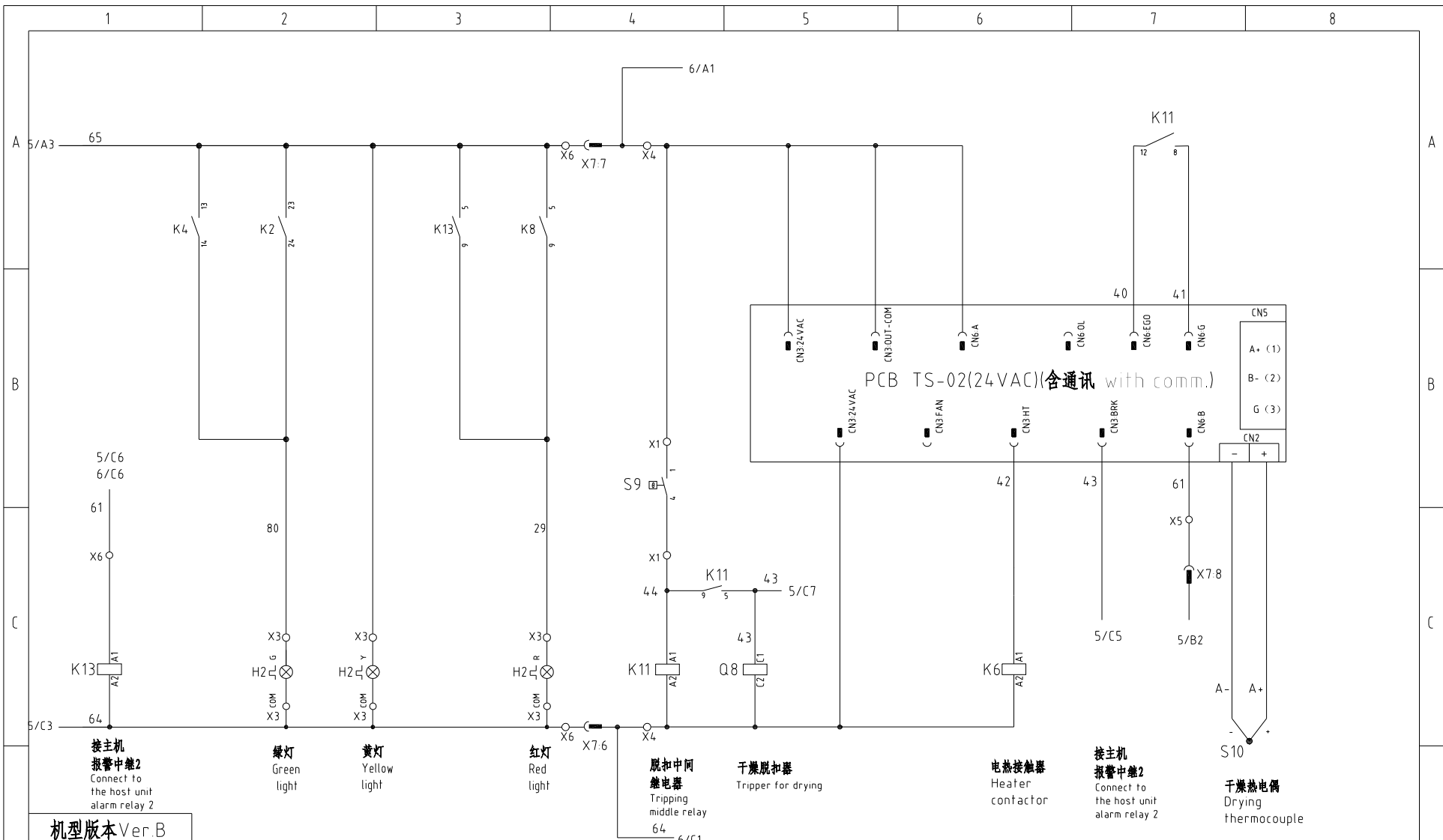

接主机  
报警中继2  
Connect to  
the host unit  
alarm relay 2

绿灯  
Green  
light

黄灯  
Yellow  
light

红灯  
Red  
light

脱扣中间  
继电器  
Tripping  
middle relay

干燥脱扣器  
Tripper for drying

电热接触器  
Heater  
contactor

接主机  
报警中继2  
Connect to  
the host unit  
alarm relay 2

干燥热电偶  
Drying  
thermocouple

机型版本 Ver.B

制图	版号	A	标题	SCD-120U×2-120H	图号	SCD-120U×2-120H-CE-400V-A-5	比例	第 5 张	
设计	核准		控制电路图三				共 10 张		
校对	核准								
标记	更改前	更改后	更改人	日期	审核	日期	2024.06.04	机器电压	3φ400V
								机器频率	50Hz



信易电热机械股份有限公司  
Shini Plastics Technologies, Inc.

标准 CE

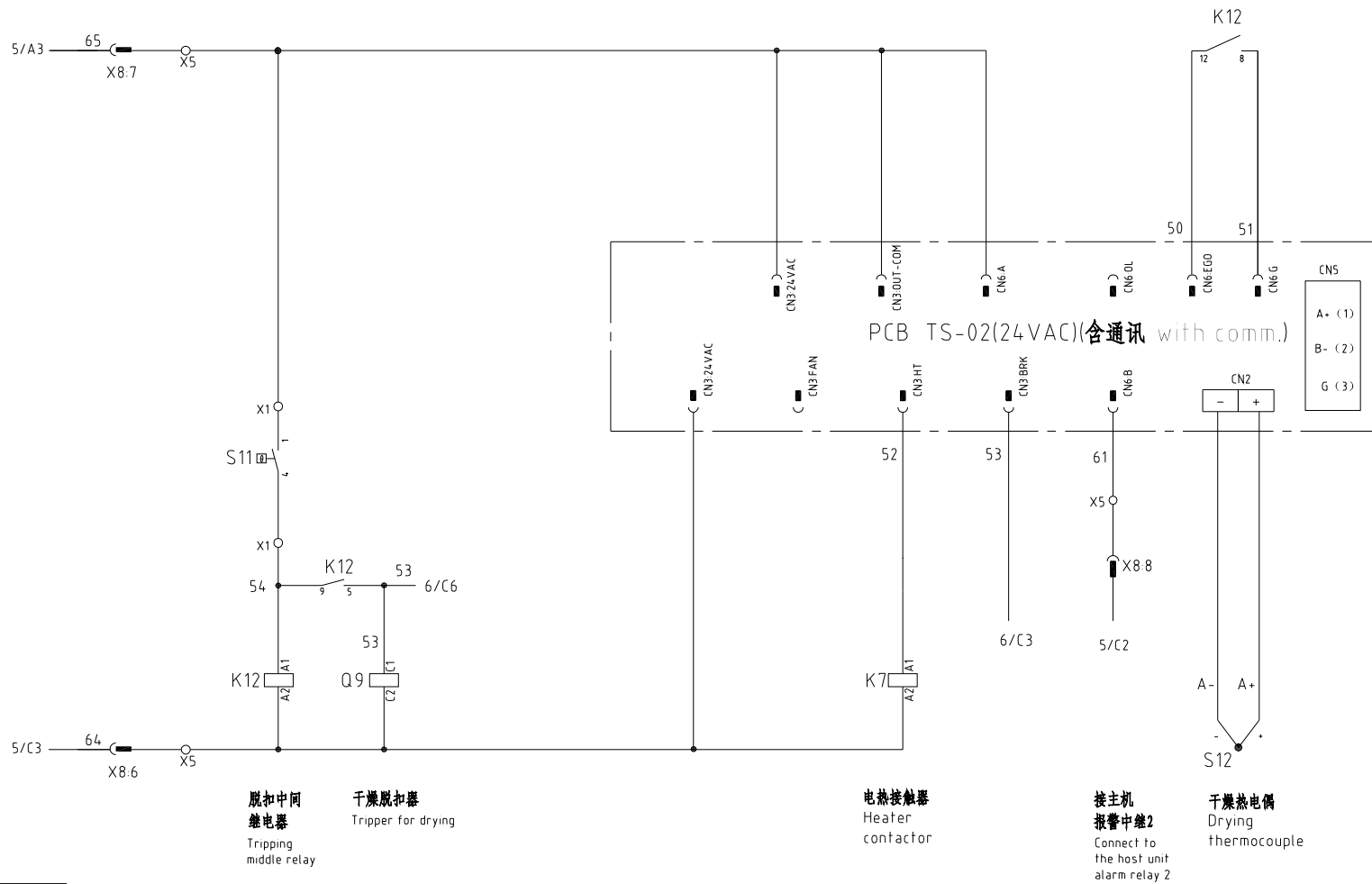

机型版本 Ver. B						制图		版号 A		标题 SCD-120U×2-120H		图号 SCD-120U×2-120H-CE-400V-A-6		比例		第 6 张	
						设计		核准		控制电路图四		标准 CE		共 10 张			
						校对		日期 2024.06.04		SHINI 信易电热机械股份有限公司 Shini Plastics Technologies, Inc.		机器电压		3φ400V			
标记						更改前		更改后		更改人		日期		审核		机器频率 50Hz	

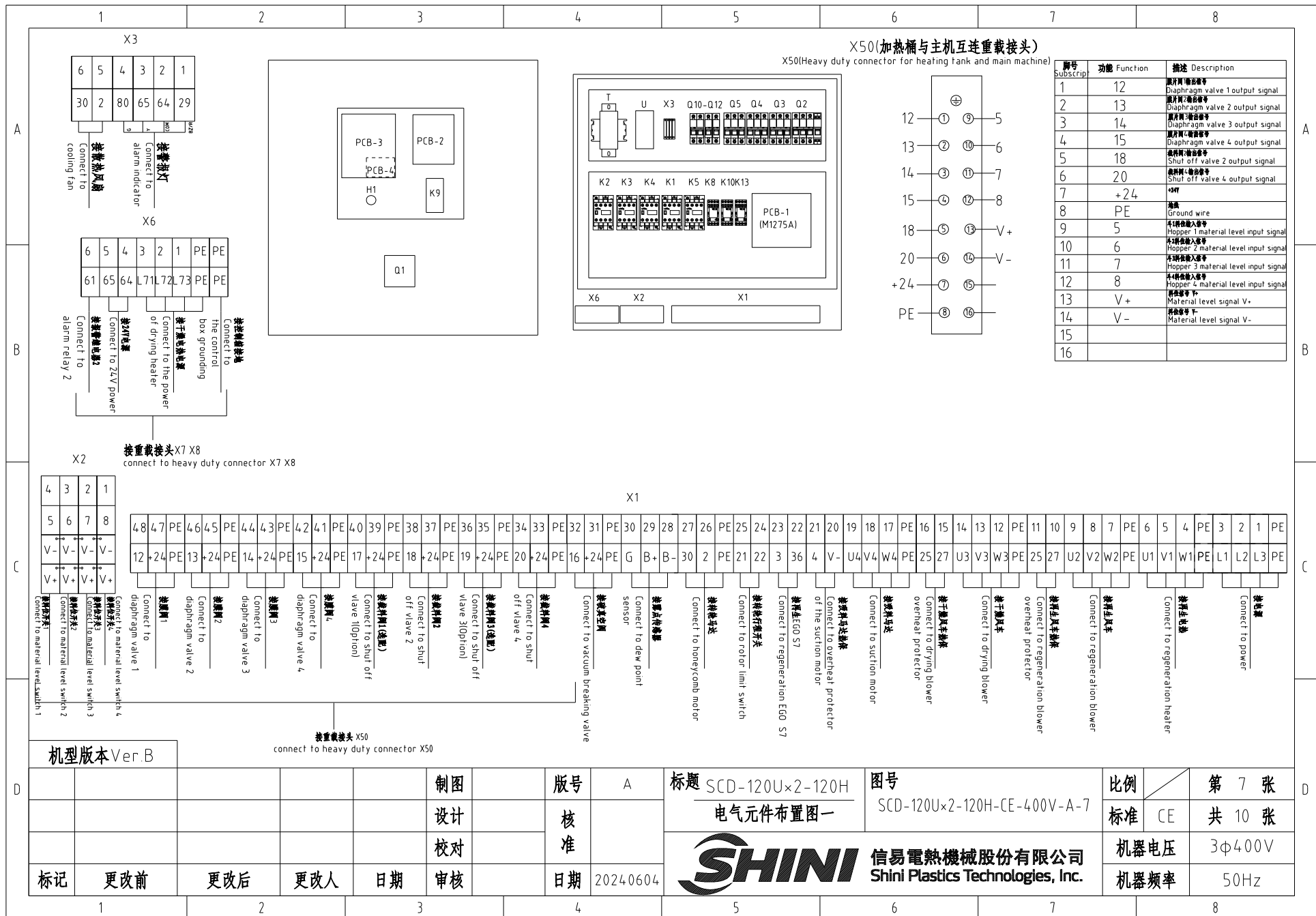

X50(加热桶与主机互连重载接头)

X50(Heavy duty connector for heating tank and main machine)

脚号 Subscript	功能 Function	描述 Description
1	12	膜片阀1输出信号 Diaphragm valve 1 output signal
2	13	膜片阀2输出信号 Diaphragm valve 2 output signal
3	14	膜片阀3输出信号 Diaphragm valve 3 output signal
4	15	膜片阀4输出信号 Diaphragm valve 4 output signal
5	18	截止阀2输出信号 Shut off valve 2 output signal
6	20	截止阀4输出信号 Shut off valve 4 output signal
7	+24	+24V
8	PE	接地 Ground wire
9	5	料斗1输入信号 Hopper 1 material level input signal
10	6	料斗2输入信号 Hopper 2 material level input signal
11	7	料斗3输入信号 Hopper 3 material level input signal
12	8	料斗4输入信号 Hopper 4 material level input signal
13	V+	料位信号+ Material level signal V+
14	V-	料位信号- Material level signal V-
15		
16		

接重载接头X7 X8  
connect to heavy duty connector X7 X8

脚号	功能	描述
1	12	膜片阀1输出信号
2	13	膜片阀2输出信号
3	14	膜片阀3输出信号
4	15	膜片阀4输出信号
5	18	截止阀2输出信号
6	20	截止阀4输出信号
7	+24	+24V
8	PE	接地
9	5	料斗1输入信号
10	6	料斗2输入信号
11	7	料斗3输入信号
12	8	料斗4输入信号
13	V+	料位信号+
14	V-	料位信号-
15		
16		
17		
18		
19		
20		
21		
22		
23		
24		
25		
26		
27		
28		
29		
30		
31		
32		
33		
34		
35		
36		
37		
38		
39		
40		
41		
42		
43		
44		
45		
46		
47		
48		

机型版本 Ver. B

接重载接头 X50  
connect to heavy duty connector X50

制图	版号	A	标题	SCD-120U×2-120H 电气元件布置图一	图号	SCD-120U×2-120H-CE-400V-A-7	比例	第 7 张
设计	核准						标准	CE
校对	核准						机器电压	3φ400V
标记	更改前	更改后	更改人	日期	20240604		机器频率	50Hz



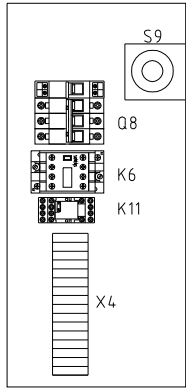

干燥桶1控制箱  
Drying hopper 1 Control box

Technical requirements: the heater directly connect to contactor output, disconnect to terminal board.

技术要求: 电热直接接接触器输出端, 不经过端子排.

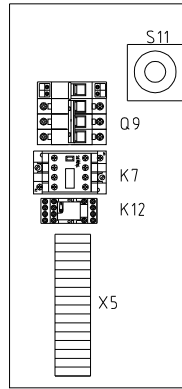
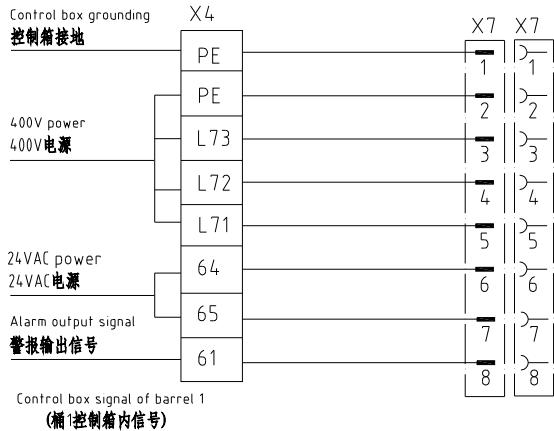

干燥桶2控制箱  
Drying hopper 2 Control box

Technical requirements: the heater directly connect to contactor output, disconnect to terminal board.

技术要求: 电热直接接接触器输出端, 不经过端子排.

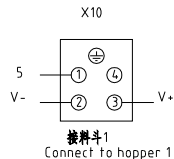
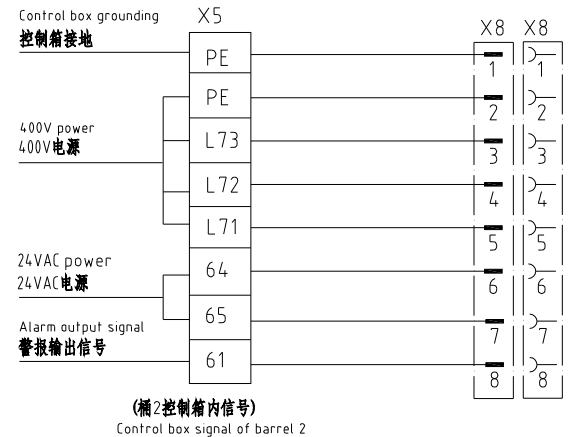

脚号 Subscript	功能 Function	描述 Description
1	料位信号(SENS) Material level signal (SENS)	接料位开关1 Connect to material level switch 1
2	GND	
3	24V+	---
4	---	

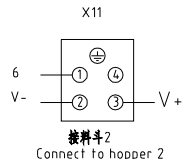

脚号 Subscript	功能 Function	描述 Description
1	料位信号(SENS) Material level signal (SENS)	接料位开关2 Connect to material level switch 2
2	GND	
3	24V+	---
4	---	

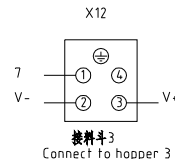

脚号 Subscript	功能 Function	描述 Description
1	料位信号(SENS) Material level signal (SENS)	接料位开关3 Connect to material level switch 3
2	GND	
3	24V+	---
4	---	

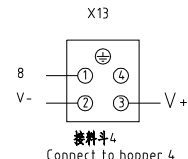

脚号 Subscript	功能 Function	描述 Description
1	料位信号(SENS) Material level signal (SENS)	接料位开关4 Connect to material level switch 4
2	GND	
3	24V+	---
4	---	

机型版本 Ver.B

					制图	版号	A	标题	SCD-120U×2-120H	图号	SCD-120U×2-120H-CE-400V-A-8	比例	第 8 张
					设计	核准		电气元件布置图二		标准	CE	共 10 张	
					校对	核准				机器电压	3φ400V		
标记	更改前	更改后	更改人	日期	审核	日期	2024.06.04			SHINI 信易电热机械股份有限公司 Shini Plastics Technologies, Inc.	机器频率	50Hz	

1

2

3

4

5

6

7

8

1		2		3		4		5		6		7		8			
序号/NO	符号/Symbol	名称/Name		制造商/Manufacturer		型号/Type		规格/Specification		单位/unit	数量/Number	物料编号/Material number		备注/Remark			
1	Q1	主电源开关 /Main power Switch		EATON		P1-32/EA/SVB 32A		32A		PCS	1	YE10323200000					
2	Q2 Q5 Q8 Q9	断路器 /Circuit breaker		TECO		BM-63C/3010S		10A		PCS	4	YE40301003000					
3		脱扣器 /Tripper		CHINT		MX		110V~400V/50/60HZ		PCS	1	YE40023560000					
4		脱扣器 /Tripper		CHINT		MX		24VAC		PCS	2	YE40024000000					
5	Q3 Q4	断路器 /Tripper		TECO		BM-63C/3006S		6A		PCS	2	YE40300603000					
6	Q6 Q7	主电源开关 /Main power Switch		EATON		T0-2-1/EA/SVB/20A		20A		PCS	2	YE10021160000					
7	Q10	断路器/Circuit breakers		TECO		BM-63C		3A		PCS	1	YE40200203000					
8	Q11 Q12	断路器/Circuit breakers		TECO		BM-63C		3A		PCS	2	YE40100203000					
9	K1~K4	交流接触器/ AC Contactors		SIEMENS		3RT6016-1AN21		9A 1NO 220V 50/60Hz		PCS	4	YE00601621000					
10		辅助触点/Auxiliary contacts		SIEMENS		3RH6911-1AA10		1AA10		PCS	1	YE00691110000					
11	K6 K7	交流接触器/AC Contactors		SIEMENS		3RT6016-1AB01		9A 1NO 24V 50/60Hz		PCS	2	YE00601602500					
12	K5	交流接触器/AC Contactors		SIEMENS		3RT6018-1AN21		16A NO 220V 50/60Hz		PCS	1	YE00601800000					
13	K8 K10	中间继电器 /Middle relay		WEIDMULLER		DRM270730LT		230V 50/60Hz		PCS	2	YE03270700000					
14	K9	露点显示器/Dew-point displayer		SHINI		Dewpoint Meter		220V 50/60Hz		PCS	1	YE85122000100		(2)			
15	K11 K12 K13	中间继电器 /Middle relay		HONEYWELL		GR-2C-AC24V底座 base PGR-2C-E		24V 50/60Hz		PCS	3	YE03022400300					
16	S5	露点变送器/Dew-point transducer		VAISALA		DMT141		POWER=24VDC 4-20mA		PCS	1	YE90014100100		(1) (2)			
17	T	互感变压器 /Sensor Transformer		JIUXIN		IN=400V OUT=230V/24V		1000mA/80VA		PCS	1	YE70040008800					
18	U	直流电源 /DC Power		DELTA		PMT-24V35W2BA		---		PCS	1	YE70243500000					
19	PCB-1 (PCB-2)	微电脑控制板/Microprocessor control board		HONGYUN		M1275		一对四 one-to-four		PCS	1	YE80127500000					
20	PCB-3	微电脑控制板/Microprocessor control board		YUYUN		TU-01A+SA-RCS2		220VAC		PCS	1	YE80001100000					
21	PCB-4	微电脑控制板/Microprocessor control board		YUYUN		TU-01B		-----		PCS	1	YE80001100100					
22	PCB-5 PCB-6	干燥机线路板/Dryer circuit board		YUYUN		TS-02(24VDC/AC)(组零件 Assembly)		24VAC		PCS	2	YE80022401200					
23	X1-X6	端子排/Terminal Board		Honeywell		4mm <sup>2</sup>		----		PCS	15	YE60000403200					
24		端子排/Terminal Board		Honeywell		4mm <sup>2</sup> PE		----		PCS	5	YE60000403500					
25		端子排/Terminal Board		Honeywell		2.5mm <sup>2</sup>		----		PCS	48	YE60002503200					
机型版本 Ver.B		注: (1)表示非电控箱内材料; (2)表示选配露点; (3)表示选配截料阀; Notes: (1)Means it 's not the material inside the control box. (2)optional dewpoint. (3)Optional shut off valve.															
				制图		版号		A		标题		图号		比例		第 9 张	
				设计		核		电器明细		SCD-120U×2-120H		SCD-120U×2-120H-CE-400V-A-9		标准		CE	
				校对		准				SCD-120U×2-120H-CE-400V-A-9		SCD-120U×2-120H-CE-400V-A-9		机器电压		3φ400V	
标记		更改前		更改后		更改人		日期		20240604		SHINI 信易電熱機械股份有限公司 Shini Plastics Technologies, Inc.		机器频率		50Hz	
1		2		3		4		5		6		7		8			

1	2	3	4	5	6	7	8		
序号/NO	符号/Symbol	名称/Name	制造商/Manufacturer	型号/Type	规格/Specification	单位/unit	数量/Number	物料编号/Material number	备注/Remark
26		端子排/Terminal Board	Honeywell	2.5mm <sup>2</sup> PE	----	PCS	15	YE60002503400	
27		端子排/Terminal Board	Honeywell	6mm <sup>2</sup>	----	PCS	3	YE60000603200	(2)
28		端子排/Terminal Board	Honeywell	6mm <sup>2</sup> PE	----	PCS	1	YE60000603500	
29		端子排/Terminal board	Honeywell	三脚簧端子SK25-TL Three-layer spring terminal	10A 250V	PCS	4	YE60002503600	
30		端子排/Terminal board	HONEYWELL	SK-2.5TL桥接件 bridgeware	10A 250V	PCS	0.7	YE60001003600	
31		终端固定件E/GK系列 Terminal fittings E/GK series	HONEYWELL	SK-2.5TL桥接件 bridgeware	10A 250V	PCS	5	YE60000003900	
32		蜂鸣器/Buzzer	HONEYWELL	PK-27A/29EP(DC3-24V)	24VDC	PCS	1	YE84002700000	
33	H1	重载接插件/Heavy Duty Connector	----	4P+PE(母座)Han 4-F(插针)Haoting	4P 10A	PCS	4	YE68000401400	(1)
34	X10,X11,X12,X13	重载接头 /Heavy duty connector	HARTING	10P+PE(公插+母座) Han E-10M/F	4P 10A	PCS	2	YE68001001300	(1)
35	X7 X8	重载接头 /Heavy duty connector	HARTING	16P+PE(公插+母座) Han E-16M/F(插针)不插G21		PCS	1	YE68001601300	(1)
36	X50	三色报警灯(红黄绿)三色报警灯 3-color alarm lamp (Red, green, yellow lights + buzzer) SWI-P-10/20	HARTING	优先级 Priority	24V 50/60Hz	PCS	1	BL90002401520	(1)
37	H2	一二三线端子排材料组合面板SD-90H2/100H-ALL-V4(版中英文 panel Ver.0 chinese and english)	SHINI	SWI-P	AC/DC24	PCS	1	YR01801000000	(1)
--	Y1-Y7	电磁阀/Solenoid valve	----	SPDV-38	24VDC		7	----	(1)
--	Y8 Y9	电磁阀/Solenoid valve	----	----	24VDC		2	----	(1) (3)
--	S6	微动开关/Micro switch	----	YBLXW-5/11G2	----		1	----	(1)
--	FM	排气扇/Fan	----	12×12CM/230V/50/60HZ	配塑胶网 With plastic net		1	----	(1)
--	M1	干燥风机/Drying blower	SHINI	HTB75-032	0.4KW 380V 50Hz		1	----	(1)
--	M2	再生风机/Regen blower	SHINI	RB205	0.4KW 380-415V 50Hz		1	----	(1)
--	M3	吸料风机/Suction blower	SHINI	RB420	1.5KW 380-415V 50Hz		1	----	(1)
--	M4	减速马达/Gear motor	SHINI	3GN-10XK/3GN-60K/3IK15GN-C-T	220V		1	----	(1)
--	EH1	电热/Heater	SHINI	SD/SDD/SCD-3KW3Φ230/400V	----		1	----	(1)
--	EH2 EH3	电热/Heater	SHINI	SHD-80U(3.9KW)3Φ400V	400V 50Hz 3.9KW		2	----	(1)
--	S7 S9 S11	组合体EG0/EG0 assembly	SHINI	(115-320℃ 55.13262.160)	----		3	----	(1)
--	S8 S10 S12	热电偶 /Thermocouple	SHINI	SD-30H/120H(2.5M)MY07	----		3	----	(1)

机型版本 Ver.B

注: (1)表示非电控箱内材料; (2)表示选配露点; (3)表示选配截料阀; Notes: (1)Means it's not the material inside the control box. (2)optional dewpoint. (3)Optional shut off valve.

制图		版号		A		标题		SCD-120U×2-120H		图号		比例		第 10 张	
设计		核				电气元件明细表二		SCD-120U×2-120H-CE-400V-A-10		标准		CE		共 10 张	
校对		准						<b>信易电热机械股份有限公司</b> <b>Shini Plastics Technologies, Inc.</b>		机器电压		3φ400V			
标记		日期		2024.06.04						机器频率		50Hz			
1	更改前	更改后	更改人	日期	审核	日期	2024.06.04	6	7	8					