

**SCD Series**  
**"All-in-One" Compact Dryer**

Date: Jul. 2017

Version: Ver.F (English)





## Contents

<b>1. General Description</b>	<b>9</b>
1.1 Coding Principle	10
1.2 Features	10
1.3 Technical Specifications	11
1.3.1 Technical Specification	11
1.3.2 Specifications	11
1.3.3 Drying Capacity	14
1.4 Safety Regulations	16
1.4.1 Safety Regulations for the Blowers	16
1.4.2 Safety Signs and Labels	17
1.4.3 Transportation and Storage of the Machine	17
1.5 Exemption Clause	19
<b>2. Structure Characteristics and Working Principle</b>	<b>20</b>
2.1 Working Principle	20
2.2 Relative Humidity and Dew-point	21
2.3 Why Choose "All-in-One" Compact Dryer	21
2.4 Options	22
<b>3. Installation Testing</b>	<b>25</b>
3.1 Machine Location	25
3.2 Air pipe and material pipe connection	26
3.3 Water connections	27
3.3.1 Cooling Water Connection	27
3.3.2 Condensation Drainage Pipe	28
3.4 Power Connectors	28
3.5 Air Supply Connection	29
3.6 Notes of optional material storage bin (MST-80U-OP)	29
3.7 Notes of optional HEPA	29
3.8 Notes for optional SHR-CP-3U	30
3.9 Cyclone Dust Collector	31
3.10 Oil Filter	32
3.11 Plate Heat Exchanger	32

<b>4. Application and Operation .....</b>	<b>33</b>
4.1 Operation Procedure for HMI(Optional).....	33
4.1.1 Description of touch screen.....	33
4.1.2 Touch panel appear error.....	33
4.1.3 Screen operation flow Table .....	34
4.1.4 Menu Particular.....	34
4.1.4.1 System Default Screen.....	34
4.1.4.2 Dehumidifying Process.....	35
4.1.4.3 Password Unlock.....	35
4.1.4.4 Working Modes of Regeneration Heater (Dehumidifying Function)38	
4.1.4.5 Working Modes of Material Drying.....	41
4.1.4.6 Alarms Fault Records .....	43
<b>5. Trouble-shooting .....</b>	<b>45</b>
<b>6. Maintenance and Repair.....</b>	<b>47</b>
6.1 Filter & Pressure Regulating Valve.....	48
6.1.1 Filter & Pressure Regulating Valve Drawing .....	48
6.1.2 Filter & Pressure Regulating Valve Operation steps .....	48
6.2 Air Filters .....	48
6.3 Blower Motors.....	49
6.3.1 Drying Blower.....	49
6.3.2 Regeneration Blower .....	49
6.3.3 Conveying Blower .....	50
6.3.4 Blower Cleaning.....	50
6.4 Heater Assemblies .....	51
6.5 The Useful Life of the Key Parts of the Product.....	51
6.6 Honeycomb-rotor.....	52
6.6.1 What is Honeycomb-rotor .....	52
6.6.2 Installation of the Rotor .....	52
6.7 EGO .....	54
6.8 Cooler.....	55
6.9 Dewpoint Monitor(Optional).....	55
6.9.1 Installation for Dewpoint Monitor.....	55
6.9.2 Dew-point monitor setting .....	58

6.10 Maintenance Schedule .....	59
6.10.1 General Machine Information.....	59
6.10.2 Installation & Inspection.....	59
6.10.3 Daily Checking.....	59
6.10.4 Weekly Checking .....	59
6.10.5 Monthly Checking .....	60
6.10.6 Half-yearly Checking.....	60
6.10.7 Yearly Checking.....	60
6.10.8 3 year Checking.....	60

### **Table Index**

Table 1-1: Specifications 1(Fully-integral design).....	11
Table 1-2: Specifications 2(Fully-integral design).....	12
Table 1-3: Specifications (Semi-integral design) .....	13
Table 1-4: Drying capacity 1 .....	14
Table 1-5: Drying capacity 2 .....	15
Table 6-1: The useful life of the key parts of the product .....	51

### **Picture Index**

Picture 1-1: Technical specifications .....	11
Picture 1-2: Safety regulations for the blowers.....	16
Picture 2-1: SCD working principle.....	20
Picture 2-2: SCD-OP working principle (With plate heat exchanger) (Option) ..	20
Picture 3-1: Installation drawing .....	25
Picture 3-2: Schematic drawing of installation (Fully-integral design) .....	26
Picture 3-3: Schematic drawing of installation (semi-integral design) .....	26
Picture 3-4: Cooling water connection.....	27
Picture 3-5: Material stage bin of optical grade MST-80U-OP .....	29
Picture 3-6: High-efficiency filter.....	30
Picture 3-7: Important notices for using.....	31
Picture 3-8: Installation diagram of cyclone dust collector.....	31
Picture 3-9: Installation diagram of oil filter .....	32

Picture 3-10: Plate heat exchanger over figure .....	32
Picture 4-1: Description of Touch Screen.....	33
Picture 4-2: Screen Operation Flow Table .....	34
Picture 4-3: System Initial Screen .....	34
Picture 4-4: Dehumidifying Process Screen.....	35
Picture 4-5: Password Input Screen.....	35
Picture 4-6: Drying Process .....	36
Picture 4-7: Parameter Setting Menu Screen.....	36
Picture 4-8: Time Setting Screen .....	37
Picture 4-9: Parameter Setting .....	37
Picture 4-10: Parameter Setting Screen.....	38
Picture 4-11: Drying Process Screen .....	38
Picture 4-12: Dehumidify Process Screen.....	39
Picture 4-13: Parameter Setting Screen.....	39
Picture 4-14: Drying Process Screen .....	40
Picture 4-15: Dehumidify Process Screen.....	40
Picture 4-16: Drying Process Screen .....	41
Picture 4-17: Drying Process Screen .....	41
Picture 4-18: Recipe Setting Screen .....	42
Picture 4-19: Drying Process Screen .....	42
Picture 4-20: Drying Process Screen .....	43
Picture 4-21: Alarm Fault Records .....	43
Picture 6-1: Filter & Pressure regulating valve drawing.....	48
Picture 6-2: Air filters.....	49
Picture 6-3: Installation of blowers .....	49
Picture 6-4: Conveying blower .....	50
Picture 6-5: Blower motors.....	50
Picture 6-6: Heater assemblies .....	51
Picture 6-7: Honeycomb rotor .....	52
Picture 6-8: Installation of the rotor .....	53
Picture 6-9: EGO.....	54
Picture 6-10: Hole site.....	55
Picture 6-11: Parts of dew-point monitor .....	56
Picture 6-12: Copper joint assembly of original machine .....	56

Picture 6-13: Installation seat.....	56
Picture 6-14: Installation for transmitter.....	57
Picture 6-15: Connection of signal wire.....	57
Picture 6-16: Connection of dew-point monitor .....	58





# 1. General Description



Read this manual carefully before operation to prevent damage of the machine or personal injuries.

SCD series dehumidifying dryer possesses three functions of dehumidification, drying and two-stage conveying. It is very suitable for drying engineering plastics materials with hygroscopicity such as PA, PC, PBT, PET. Among them, optics SCD-OP could be used in processing application of lens, LCD backlight board and discs, it has dew-point of below  $-40^{\circ}\text{C}$  under ideal condition.



SCD-160U/120H



SCD-600U/400H-LC-D

## 1.1 Coding Principle

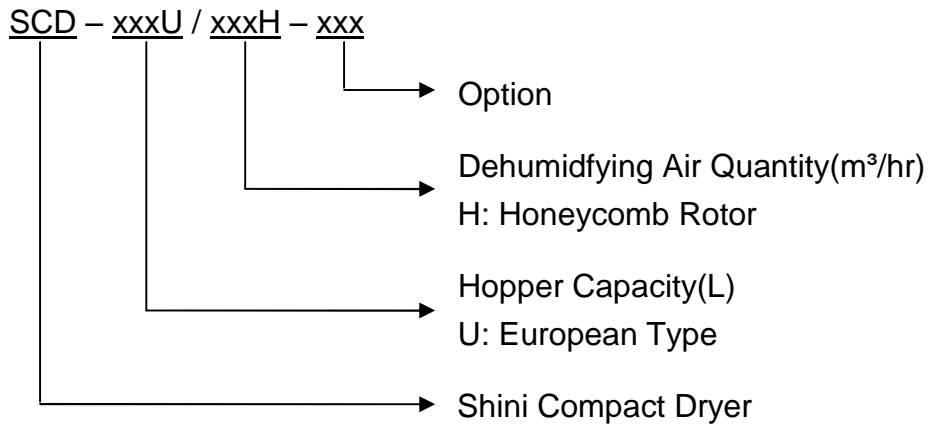

## 1.2 Features

- Combine the function of dehumidifying, drying and two-stage conveying into a single unit.
- SCD Dryer Loaders are equipped with honeycomb rotor to obtain stable low dew-point drying air. It contains two models: semi-open and hermetic.
- Feeding system is equipped with shut-off valve to ensure no surplus raw material in hopper tubes.
- Microprocessor is available as standard equipment.
- Heat preserved drying hopper barrel adopts down blowpipe design and collocates with cyclone air exhaust to avoid heat lost and improve drying efficiency.

All service work should be carried out by a person with technical training or corresponding professional experience. The manual contains instructions for both handling and servicing. Chapter 6, which contains service instructions intended for service engineers. Other chapters contain instructions for the daily operator.

Any modifications of the machine must be approved by SHINI in order to avoid personal injury and damage to machine. We shall not be liable for any damage caused by unauthorized change of the machine.

Our company provides excellent after-sales service. Should you have any problem during using the machine, please contact the company or the local vendor.

Headquarter and Taipei factory:

Tel: (886) 2 2680 9119

Shini Plastics Technologies (Dongguan), Inc:

Tel: (86) 769 8111 6600

Shini Plastics Technologies India Pvt.Ltd.:

Tel: (91) 250 3021 166

## 1.3 Technical Specifications

### 1.3.1 Technical Specification

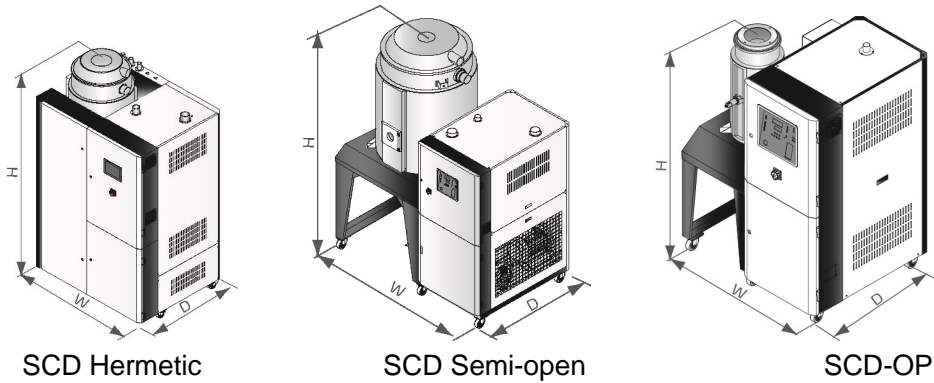

Picture 1-1: Technical specifications

### 1.3.2 Specifications

Table 1-1: Specifications 1(Fully-integral design)

Model SCD-	20U/30H-OP	40U/30H-OP	80U/50H-OP	120U/80H-OP
Ver.	D	D	D	D
Drying System				
Dying Heater Power (kW)	3	3	3.9	6
Dying Blower Power (kW)	0.4	0.4	0.4	0.75
Hopper Capacity (L)	20	40	80	120
Dehumidifying System				
Regenerating Heater Power (kW)	3	3	3	3
Regenerating Blower Power (kW)	0.4	0.4	0.4	0.4
Dehumidifying Air quantity (m <sup>3</sup> /hr)	30	30	50	80
Feeding System				
Feeding Blower Power (kW)	1.5	1.5	1.5	1.5
Dia. of Material Pipe (inch)	1.5	1.5	1.5	1.5
SHR-U-E Hopper (L)	3*	3*	3*	3*
SHR-U Hopper (L)	3	3	6	6
Dimensions				
H(mm)	1400	1500	1670	1710
W(mm)	1050	1050	1240	1240
D(mm)	900	900	1000	1000
Weight (kg)	235	280	330	385

Note: 1) Plastic materials can be fully dried by drying air with dew-point temperature  $\leq -20^{\circ}\text{C}$ . When ambient temperature  $\leq -25^{\circ}\text{C}$  and relative humidity  $\leq 60\%$ , the drying air dewpoint temp.  $\leq -40^{\circ}\text{C}$ .

2) "\*" stands for hopper receiver SHR-CP-U.

3) Power: 3 $\Phi$ , 230 / 400 / 460 / 575VAC, 50 / 60Hz.

We reserve the right to change specifications without prior notice.

Table 1-2: Specifications 2(Fully-integral design)

Model SCD-	20U/40H	40U/40H	80U/40H	120U/80H	160U/80H	160U/120H	230U/120H	300U/200H	450U/200H
Ver.	C	C	C	D	D	D	C	C	C
Drying System									
Dying Heater Power (kW)	4	4	4	6	6	6	6	12	12
Dying Blower Power (kW, 50/60Hz)	0.12	0.12	0.12	0.75	0.75	0.75	0.75	1.5	1.5
Hopper Capacity (L)	20	40	80	120	160	160	230	300	450
Dehumidifying System									
Regenerating Heater Power (kW)(50/60Hz)	3 / 3	3 / 3	3 / 3	3 / 4	3 / 4	3 / 4	3 / 4	4 / 6	4 / 6
Regenerating Blower Power (kW, 50/60Hz)	0.4	0.4	0.4	0.4	0.4	0.4	0.4	0.4	0.4
Dehumidifying Air quantity (m <sup>3</sup> /hr, 50/60Hz)	40	40	40	80	80	120	120	200	200
Feeding System									
Feeding Blower Power (kW, 50/60Hz)	1.5	1.5	1.5	1.5	1.5	1.5	1.5	1.5	1.5
Dia. of Material Pipe (inch)	1.5	1.5	1.5	1.5	1.5	1.5	1.5	1.5	1.5
SHR-U-E Hopper (L)	3	3	6	6	6	6	12	12	12
SHR-U Hopper (L)	3	3	6	6	6	6	12	12	12
Dimensions									
H(mm)	1490	1550	1645	1990	1860	1860	2070	2160	2570
W(mm)	1000	1040	1105	1105	1190	1190	1190	1460	1460
D(mm)	880	880	880	875	875	875	875	1020	1020
Weight (kg)	280	295	325	340	385	505	515	565	595

Note: 1) Plastic materials can be fully dried by drying air with dew-point temperature  $\leq -20^{\circ}\text{C}$ . When ambient temperature  $\leq -25^{\circ}\text{C}$  and relative humidity  $\leq 60\%$ , the drying air dewpoint temp.  $\leq -40^{\circ}\text{C}$ .

2) "\*" stands for hopper receiver SHR-CP-U.

3) Power: 3 $\Phi$ , 230 / 400 / 460 / 575VAC, 50 / 60Hz.

We reserve the right to change specifications without prior notice.

Table 1-3: Specifications (Semi-integral design)

Model SCD-	600U/400H	750U/400H	900U/700H	1200U/700H
Ver.	C	C	F	F
Drying System				
Drying Heater Power (kW)	18	18	24	24
Drying Blower Power (kW, 50/60Hz)	3.75 / 4.5	3.75 / 4.5	7.5 / 8.6	7.5 / 8.6
Hopper Capacity (L)	600	750	900	1200
Dehumidifying System				
Regenerating Heater Power (kW)	7.2	7.2	10	10
Regenerating Blower Power (kW, 50/60Hz)	0.75 / 0.9	0.75 / 0.9	1.5 / 1.8	1.5 / 1.8
Dehumidifying Air quantity (m <sup>3</sup> /hr, 50/60Hz)	400 / 450	400 / 450	700 / 780	700 / 780
Feeding System				
Feeding Blower Power (kW)	1.5	1.5	3.75	3.75
Dia. of Material Pipe (inch)	1.5	1.5	2	2
SHR-U-E Hopper Receiver (L)	12	12	24	24
SHR-U Hopper Receiver (L)	12	12	24	24
Dimensions				
H(mm)	2380	2610	2640	3070
W(mm)	1745	1745	2140	2140
D(mm)	1255	1255	1380	1380
Weight (kg)	640	690	850	900

Note: 1) Plastic materials can be fully dried by drying air with dew-point temperature  $\leq -20^{\circ}\text{C}$ . When ambient temperature  $\leq -25^{\circ}\text{C}$  and relative humidity  $\leq 60\%$ , the drying air dewpoint temp.  $\leq -40^{\circ}\text{C}$ .

2) "\*" stands for hopper receiver SHR-CP-U.

3) Power: 3 $\Phi$ , 230 / 400 / 460 / 575VAC, 50 / 60Hz.

We reserve the right to change specifications without prior notice.

### 1.3.3 Drying Capacity

Table 1-4: Drying capacity 1

Material	Drying Temp. (°C)	Drying Time(hr)	Drying Capacity (kg/hr)							
			20U /40H	40U /40H	80U /40H	120U /80H	160U /80H	160U /120H	230U /120H	300U /200H
ABS	80	2-3		16		27		35		105
CA	75	2-3		12		22		30		90
CAB	75	2-3		12		22		30		90
CP	75	2-3		16		27		35		106
LCP	150	4		11		20		27		80
POM	100	2		24		40		53		160
PMMA	80	3		17		29		38		115
IONOMER	90	3-4		10		17		22		66
PA6/6.6/6.10	75	4-6		9		14		19		58
PA11	75	4-5		10		17		23		69
PA12	75	4-5		10		17		23		69
PC	120	2-3		19		31		41		124
PU	90	2-3		17		29		38		115
PBT	130	3-4		13		23		31		93
PE	90	1		47		80		106		318
PEI	150	3-4		11		20		27		80
PET	160	4-6		11		19		25		75
PETG	70	3-4		11		20		27		80
PEN	170	5		13		23		30		90
PES	150	4		13		23		30		90
PMMA	80	3		17		29		28		115
PPO	110	1-2		19		33		44		133
PPS	150	3-4		11		20		27		80
PI	120	2		24		40		53		160
PP	90	1		39		66		88		265
PS(GP)	80	1		39		66		88		265
PSU	120	3-4		12		22		29		85
PVC	70	1-2		19		33		44		135
SAN(AS)	80	1-2		19		33		44		135
TPE	110	3		18		30		40		125

Note: 1. Please refer to above drying capacity of SCD machine, select the right model according to material usage of processing machine.

2. Please consult Shini service staff for model selection.

Table 1-5: Drying capacity 2

Material	Drying Temp. (°C)	Drying Time(hr)	Drying Capacity (kg/hr)			
			600U /400H	750U /400H	900U /700H	1200U /700H
ABS	80	2-3	210		355	
CA	75	2-3	180		295	
CAB	75	2-3	180		295	
CP	75	2-3	210		355	
LCP	150	4	160		365	
POM	100	2	320		530	
PMMA	80	3	230		383	
IONOMER	90	3-4	133		220	
PA6/6.6/6.10	75	4-6	115		192	
PA11	75	4-5	138		230	
PA12	75	4-5	138		230	
PC	120	2-3	250		413	
PU	90	2-3	230		383	
PBT	130	3-4	186		310	
PE	90	1	637		1062	
PEI	150	3-4	160		265	
PET	160	4-6	150		250	
PETG	70	3-4	160		265	
PEN	170	5	180		300	
PES	150	4	180		300	
PMMA	80	3	230		385	
PPO	110	1-2	265		440	
PPS	150	3-4	160		265	
PI	120	2	320		530	
PP	90	1	530		885	
PS(GP)	80	1	531		885	
PSU	120	3-4	173		290	
PVC	70	1-2	265		442	
SAN(AS)	80	1-2	265		442	
TPE	110	3	250		413	

Note: 1. Please refer to above drying capacity of SCD machine, select the right model according to material usage of processing machine.

2. Please consult Shini service staff for model selection.

## 1.4 Safety Regulations

### 1.4.1 Safety Regulations for the Blowers

- 1) Under normal operation, the blowers will generate high temperature. Do not touch blower's case to avoid any physical injury.
- 2) Under normal operation, the blower motor's current loading will increase or reduce according to air pressure's change accordingly. While installation, an adequate motor overload protection switch should be installed with full loading test, to ensure operating safely under full-loading to avoid motor's damage.
- 3) To avoid any block materials, dust, powder, fiber particles and water drops entering the blower, and hence cause the deficiency of its performance. This machine is well designed with air filters, so please clean up the filter with any foreign particles (recommended to clean up this filter weekly).
- 4) Clean the blowers both internal and external parts (especially for the fan cooling path), and remove surface dust if necessary. If more dusts are accumulated, it will cause deficiency for ventilation, temperature rising, vacuum power reduced, vibration increased and so it will cause machine broke down.
- 5) Ball bearing, oil seal and soundproof are belonging to consumable parts and so it has a life period and equires regular replacement. Meanwhile, blade, external case, and metallic screen etc. should be replaced regularly for best performance.
- 6) Under normal operation, if the blowers are not running smoothly or abnormal noise appeared. Please immediately shut down the machine for repair.

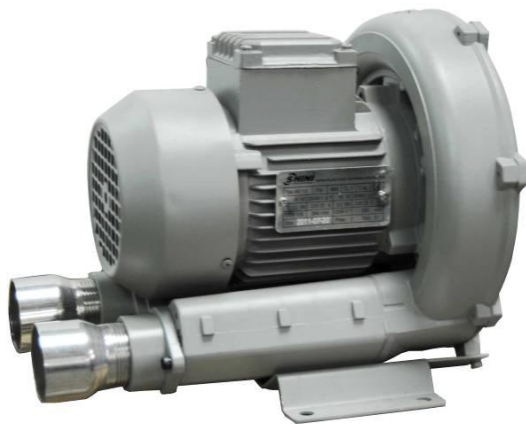

Picture 1-2: Safety regulations for the blowers



## 1.4.2 Safety Signs and Labels



Danger!

High voltage danger!

This label is stuck on the electrical boxes.



Attention!

This label means that this area should be taken care!



Warning!

High temperature, take care of hands!

This label should be stick to the shell of heater.



Attention!

No need for regular inspection because all the electrical parts in the control unit are fixed tightly!



Note!

The EGO over-temperature protection is only for process heater protection, not for material protection usage, the default setting should not be changed.

## 1.4.3 Transportation and Storage of the Machine

Transportation:

- 1) SCD series "All-in-one" compact dryer are packed in crates or plywood cases with wooden pallet at the bottom, suitable for quick positioning by fork lift.
- 2) After unpacked, castors equipped on the machine can be used for ease of movement.
- 3) Do not rotate the machine and avoid collision with other objects during transportation to prevent improper functioning.
- 4) The structure of the machine is well-balanced, although it should also be handled with care when lifting the machine for fear of falling down.
- 5) The machine and its attached parts can be kept at a temperature from  $-25^{\circ}\text{C}$  to  $+55^{\circ}\text{C}$  for long distance transportation and for a short distance, it can be transported with temperature under  $+70^{\circ}\text{C}$ .

### Storage:

- 1) SCD series "All-in-One" compact dryer should be stored indoors with temperature kept from 5°C to 40°C and humidity below 80%.
- 2) Disconnect all power supply and turn off main switch and control switch.
- 3) Keep the whole machine, especially the electrical components away from water to avoid potential troubles caused by the water.
- 4) Plastic film should be used to protect the machine from dust and rains.

### Working environment:

Indoors in a dry environment with max. temperature +45°C and humidity no more than 80%.

### Do not use the machine:

- 1) If it is with a damaged cord.
- 2) On a wet floor or when it is exposed to rain to avoid electrical shock.
- 3) If it has been dropped or damaged until it is checked or fixed by a qualified serviceman.
- 4) This equipment works normally in the environment with altitude within 3000m.
- 5) At least a clearance of 1m surrounding the equipment is required during operation. Keep this equipment away from flammable sources at least two meters.
- 6) Avoid vibration, magnetic disturbance at the operation area.

### Rejected parts disposal

When the equipment has run out its life time and can not be used any more, unplug the power supply and dispose of it properly according to local code.

Fire hazard.



In case of fire, CO<sub>2</sub> dry powder fire extinguisher should be applied.

## 1.5 Exemption Clause

The following statements clarify the responsibilities and regulations born by any buyer or user who purchases products and accessories from Shini (including employees and agents).

Shini is exempted from liability for any costs, fees, claims and losses caused by reasons below:

1. Any careless or man-made installations, operation and maintenances upon machines without referring to the Manual prior to machine using.
2. Any incidents beyond human reasonable controls, which include man-made vicious or deliberate damages or abnormal power, and machine faults caused by irresistible natural disasters including fire, flood, storm and earthquake.
3. Any operational actions that are not authorized by Shini upon machine, including adding or replacing accessories, dismantling, delivering or repairing.
4. Employing consumables or oil media that are not appointed by Shini.

## 2. Structure Characteristics and Working Principle

### 2.1 Working Principle

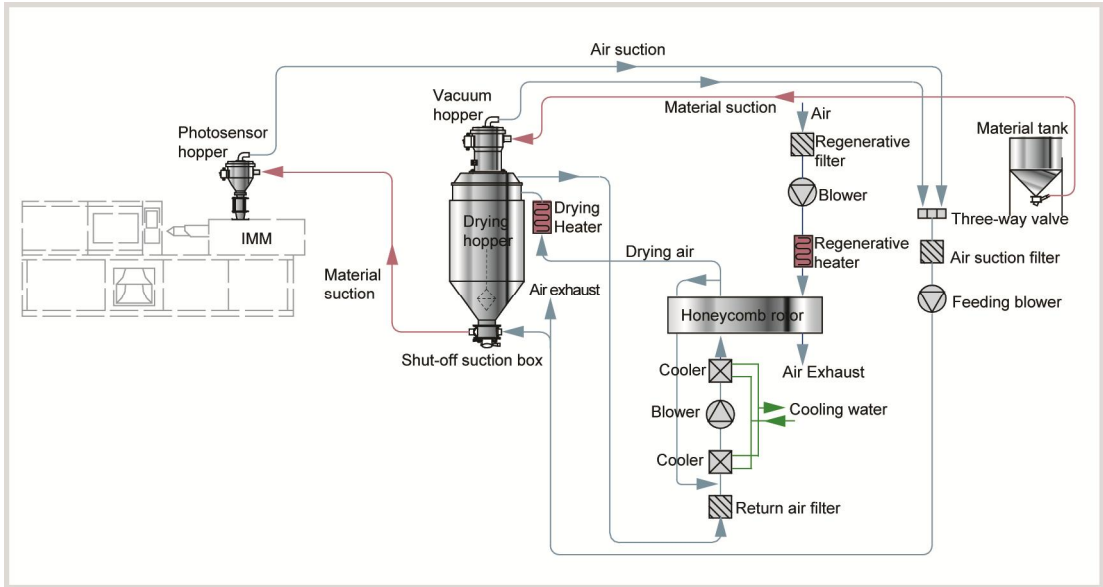

Picture 2-1: SCD working principle

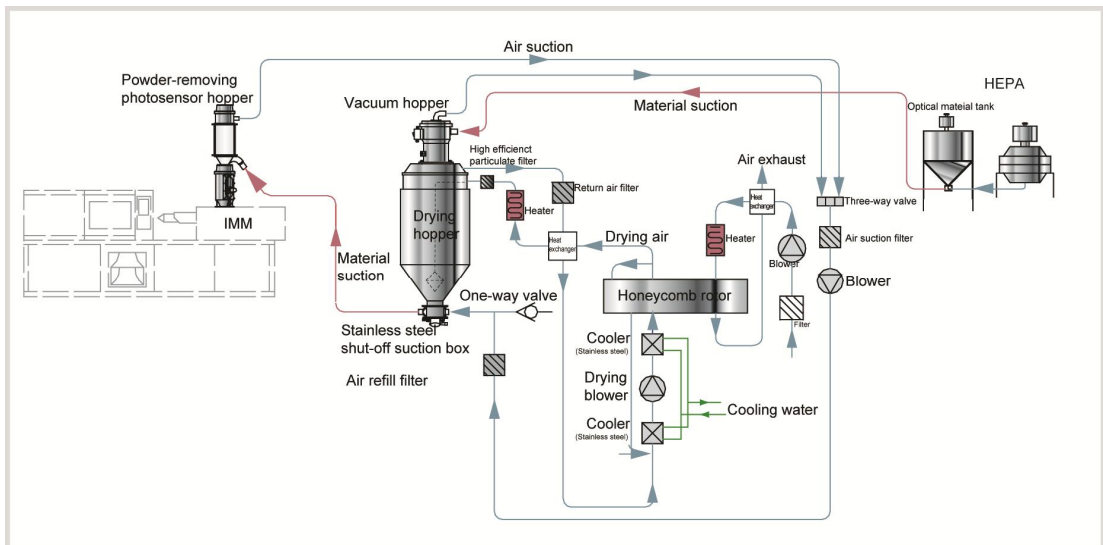

Picture 2-2: SCD-OP working principle (With plate heat exchanger) (Option)  
 Dehumidifying: damp and hot air from dry material barrel is blown into rotor after cooled. Moisture from the air is absorbed by rotor and is then adsorbed by regeneration heating air. Two strands of airflow function on the rotor. And with

the rotation, moisture from the air is absorbed and expelled after absorbed regeneration air to form stable low dew-point air, which is dried to the drying temperature and then is blown into material barrel to closed circle to dry material.

Suction: material is absorbed into barrel from storage barrel or other storage containers. When the magnetic reed switch detects no material, suction motor runs to produce vacuum inside vacuum hopper. Raw material in storage barrels is absorbed into suction hopper due to air pressure difference. When the time is completed, suction motor stops. Raw materials drop into drying hopper barrel due to gravity. The dried raw material after dried from is taken out to the hopper with photosensor installed on moulding machine or other hopper form

drying hopper barrel.

## 2.2 Relative Humidity and Dew-point

Relative humidity: Relative air humidity means real vapor content to saturated vapor at the same temperature in percentage. Dew point: it means that temperature when the saturation vapor begins to dew. When the relative humidity is 100%, the ambient temperature is the dew point temperature. The more lower of dew point temperature (than the ambient temperature) is, the more less possible to dew, that also means the more drier the air is. The dew point will not be influenced by temperature, but influenced by pressure.

## 2.3 Why Choose "All-in-One" Compact Dryer

It is proved that the hygroscopic materials used in the plastics industry such as PC, PA, PBT, PET, Nylon, etc. cannot be dried effectively by conventional hot air drying systems because those systems depend on ambient conditions and are relatively inefficient in reducing moisture contents. These materials demand a steady low dew point dry air and a constant drying temperature, which guarantee final moisture content of 0.02% or even less. The SCD provides a closed-loop system with the dew-point of the dried air being down to  $-40^{\circ}\text{C}$  or even lower which accelerates moisture transferring from the plastic granules to the dry air.

## 2.4 Options

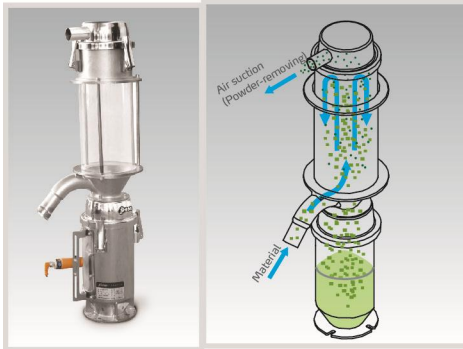

Optical Powder-removing Hopper



SCD-OP High Efficiency  
Particulate Absorbing Filter

- Optical SCD-OP series together with powder- removing hopper which can help avoid stain in the production; material contact surfaces are all mirror polished and collocates conveying system with closed loop to avoid contamination and moisture regain; system has standard configuration high efficiency particulate absorbing filter, which can filter tiny ion of  $0.3\mu\text{m}$  with filter ratio of 99.995%. (Only Apply to SCD-20U/30H~SCD-120U/80H)



High Efficiency Particulate  
Absorbing Filter HEPA( $0.3\mu\text{m}$ )



Optical Material Tank ( $5\mu\text{m}$ )

- Optical-class models can select high-efficient filter (left) and optical-class storage hopper (right) to avoid material contamination in the conveying process.
- Models optional with touch-control HMI (adopt PLC HMI), add "LC" at the end of the model code.

- Built-in type, which means that dew-point monitor is installed on the machine, is convenient to monitor dew-point temperature. Add "D" at the end of the model code.
- Portable type, which means that dew-point monitor is separate from the machine, is convenient to test dew-point temperature of different machines. Add "PD" at the end of the model code.



Dew-point Monitor (installed on machine)

Dew-point Monitor (portable)

- For models with energy-saving drying management, add "ES" at model behind, standard equipped with HMI touch control, which can save up to 41% of total power consumption. Volume used per hour is settable between 40~100% as drying capacity to save the total power consumption of 35%~0; Standard equipped with heat regenerative recycler which recycles the regeneration air exhausted heat via plate heat exchanger and can save 3%~6% of total power consumption.
- For models optional with dew-point control, add "DC" at model behind. "ES" by setting if dew-point value to control the regeneration required temperature automatically and lowers power consumption of the regenerative heater; According to -40OC~+10OC of dew-point value, the total power consumption can save 0~10%.
- For models optional with drying heat recycler, add "HE" at model behind. Dehumidified low temperature air via plate heat exchanger to recycle the heat of hot-wet return air, which can higher the air temperature in drying heater and lower the power consumption of the heater, the total power consumption can save 0%~19%.
- Three-stage conveying function is available to feed two sets of injection

molding machines. Add "M2" at the end of the model code.

- Polished surface inside of hopper, Plus "P" at the end of the model code.



Before connecting electrical power source, the main power switch must be turned to OFF position. After the machine connected with power source, turn the main power switch to ON position. According to your applications, operate drying and loading system respectively.



### 3. Installation Testing

This series of models only could be applied in working environment with good ventilation.

#### 3.1 Machine Location



Picture 3-1: Installation drawing

#### Installation Notice:

- 1) The machine can only be installed in the vertical position, make sure there's no pipeline, fixed structure and other object which may obstruct machine installation or cause items, human injuries above the selected location and adjacent areas.
- 2) For easy maintenance, leaving 1m space around machine is suggested. Keep machine 2m away from the inflammable materials.
- 3) The machine must be placed on the ground level to ensure balance state, and to remove the accumulated condensing water. If machine is need to install on a higher level (scaffolding or interlayer), it should make sure that the structure and size could withstand the machine.

### 3.2 Air pipe and material pipe connection

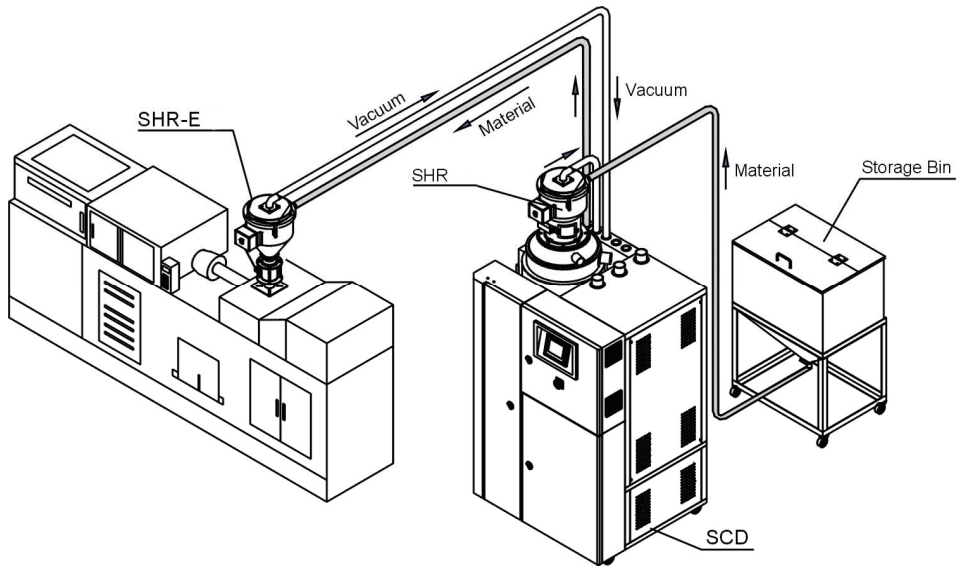

Picture 3-2: Schematic drawing of installation (Fully-integral design)

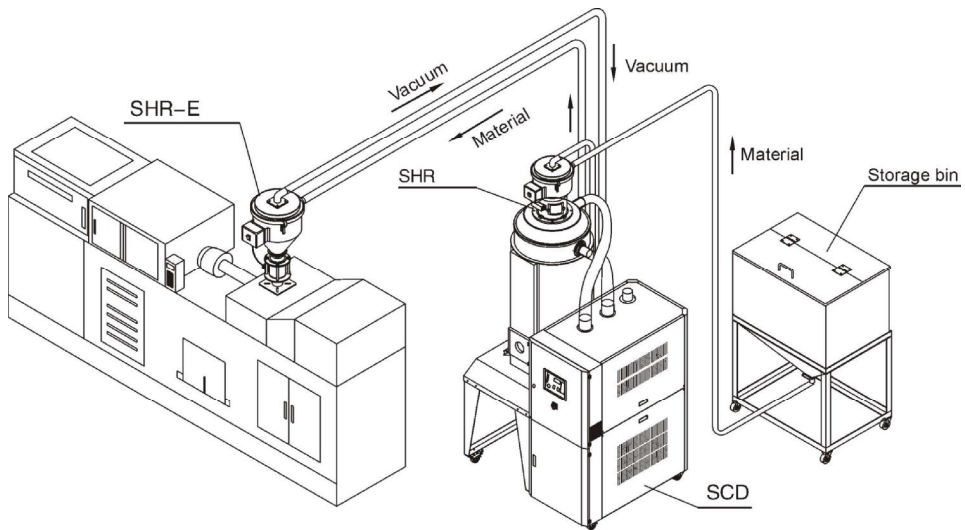

Picture 3-3: Schematic drawing of installation (semi-integral design)

### 3.3 Water connections

The cooling water pressure is 3~5bar and the cooling water temperature should be 10~30°C.

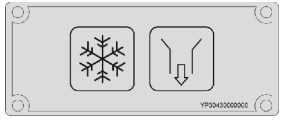
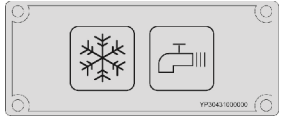
	<p>Water outlet: cooling water outlet.</p>
	<p>Water inlet: inlet for replenishing water and cooling water.</p>

cooling water needs to be connected the before operation. The water port is at the back of the machine.

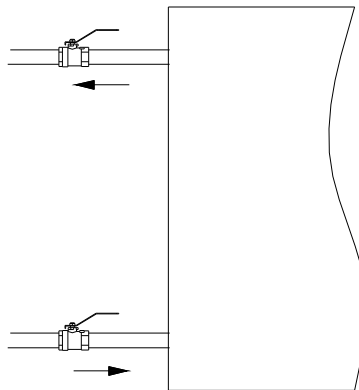

Picture 3-4: Cooling water connection

#### 3.3.1 Cooling Water Connection

Connect through the cooling water before machine operation. For the efficiency, please follow below suggestions:

- 1) For easy maintenance and safety, install the ball valve at cooling water inlet and outlet.
- 2) Water pipe diameter should not less than the diameter of cooling water inlet and outlet.
- 3) For water quality, it needs to sediment or filter the water before it gets into the pipe, to prevent the deposits accumulated on pipeline of cooler and performance degradation.

Cooling Water Specifications			
Model	Flowrate of Cooling Water (L/min)	Model	Flowrate of cooling Water (L/min)
SD-30H	4	SD-400H	50
SD-40H	5	SD-500H	60
SD-50H	6	SD-700H	80
SD-80H	10	SD-1000H	120
SD-120H	15	SD-1500H	180
SD-150H	20	SD-2000H	240
SD-200H	30	SD-3000H	360
SD-300H	40	SD-4000H	480

Note: 1. Difference in temperature: 5°C  
 2. Cooling water pressure: 3~5Kgf/cm<sup>2</sup>  
 3. Cooling water temperature: ≤30°C

### 3.3.2 Condensation Drainage Pipe

During normal operation, it will generate condensation water. Connect the water pipe at drainage outlet to remove the condensation water is necessary.

- 1) Drainage pipe inner diameter should not less than the diameter of drainage outlet.
- 2) Drainage pipe should be long enough to approach the drainage channel, and be the hose. Be careful not to press or bend the pipe for smooth water flow (Use the rigid pipe if there's need to press or bend the hose).
- 3) As condensation water drainage is in terms of gravity, make sure the drainage outlet is above the pipe. Otherwise the water can't be drained out and will flow back to the machine.

### 3.4 Power Connectors

- 1) Make sure voltage and frequency of the power source comply with those indicated on the manufacturer nameplate, attached to the machine.
- 2) Power cable and earth connections should conform with your local regulations.
- 3) Use independent electrical wires and power switch. Diameter of electrical wire should not be less than those used in the control box.
- 4) The power cable connection terminals should be tightened securely.
- 5) The machine requires a 3-phase 4-wire power source, connect the power lead (L1, L2, L3) to the live wires, and the earth (PE) to the ground.

6) Power supply requirements:

Main power voltage: +/- 10%

Main power frequency: +/- 2%

7) Specific power supply specifications please refer to the schematic model.

### 3.5 Air Supply Connection

Quality grade: 335 (solid particle concentration  $\leq 5\text{mg/m}^3$  dew-point temperature is about  $-20^\circ\text{C}$ , oil content  $\leq 25\text{mg/m}^3$ )

Air pressure: 3~5bar

Air quantity: ~10L/hr

Pipe dimension: PM20

### 3.6 Notes of optional material storage bin (MST-80U-OP)

- 1) Check whether internal bin and connecting pipe are clean or not before using.
- 2) Using equipped with HEPA and model of optional grade series.
- 3) If customer do not equip with HEPA, filter with accuracy of 5um is available, which is installed inside storage bin.



Picture 3-5: Material stage bin of optical grade MST-80U-OP

### 3.7 Notes of optional HEPA

- 1) Take note of air flow direction of plate filter, avoiding reversing side.
- 2) Take note of sequence of installation of the two plate filter, that is installed above with accuracy of 5um and below with accuracy of 0.3um.

- 3) The two plate filters are installed tightly to align locating device and keep the detection location of upper and lower pressure on the same side.
- 4) The upper low efficient filter should be cleaned timely (once a week is suggested). When air supply is lacked obviously and cleaning efficiency of cylinder type filter is not obvious, we suggest cleaning middle-efficiency filter with accuracy of 5um, or replace high-efficiency filter with accuracy of 0.3um.
- 5) It is not available for high-efficiency filter with accuracy of 0.3um to recycle for use because of vulnerability.
- 6) Differential pressure indicator optionally connects to the pressure detection location of upper and lower plate cover. When pressure difference is above 1000Pa, we suggest cleaning middle-efficiency filter with accuracy of 5um. And if the efficiency is not good, we suggest replacing high-efficiency filter with accuracy of 0.3um.



Picture 3-6: High-efficiency filter

### 3.8 Notes for optional SHR-CP-3U

- 1) Check whether the feed-in pipes are clean before using.
- 2) The screen needs regular cleaning, once a week is recommended.
- 3) The glass tube and the packing are consumables. Be careful when using and back up is necessary.
- 4) Location of the level sensor can be adjusted according to user's requirement.



Picture 3-7: Important notices for using

### 3.9 Cyclone Dust Collector

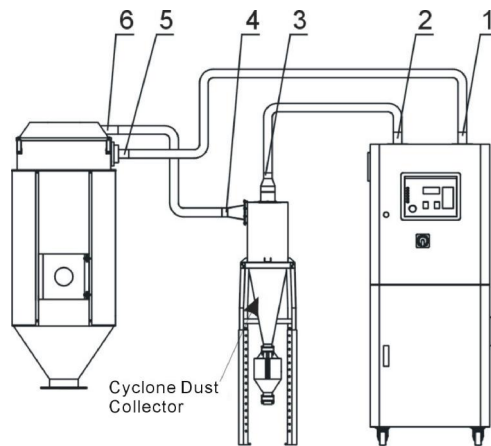

Picture 3-8: Installation diagram of cyclone dust collector

Cyclone Dust Collector Installation steps:

1. Connect 1 and 5 with a heat-resistant duct and fixed both the ends with stainless steel tube.
2. Connect 2 and 3 with a heat-resistant duct and fixed both the ends with stainless steel tube.
3. Connect 4 and 6 with a heat-resistant duct and fixed both the ends with stainless steel tube.

### 3.10 Oil Filter

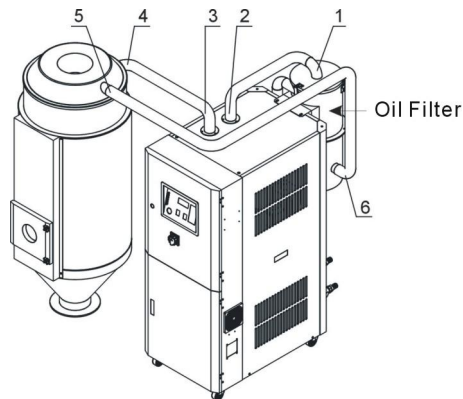

Picture 3-9: Installation diagram of oil filter

Oil filter installation steps:

1. Screw the oil filter on the top plate of the honeycomb dehumidifier.
2. Connect 1 and 2 with a heat-resistant duct and fixed both the ends with stainless steel tube.
3. Connect 3 and 4 with a heat-resistant duct and fixed both the ends with stainless steel tube.
4. Connect 5 and 6 with a heat-resistant duct and fixed both the ends with stainless steel tube.

### 3.11 Plate Heat Exchanger

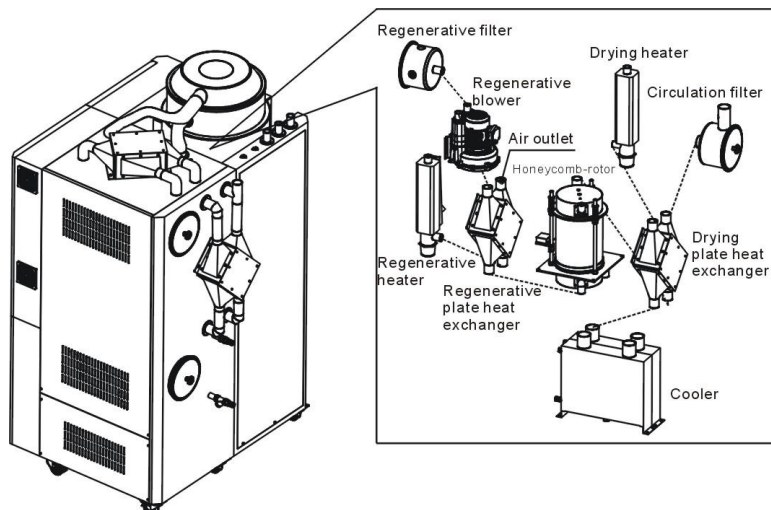

Picture 3-10: Plate heat exchanger over figure

Each part is connected by heat-resistant air pipes and fixed by stainless steel pipes as shown in the diagram.



## 4. Application and Operation

### 4.1 Operation Procedure for HMI

- 1) Do not use keen-edged object instead of hands to operate the touch screen, and prevent violent collision of it.
- 2) In a dry environment, static electricity may accumulate on the touch screen. Use a metal wire to discharge it before operating.
- 3) Use alcohol or eleoptene to wipe off the pollutants on the screen. Other solvent may cause the color of the screen to fade out.
- 4) Do not tear down any parts of the touch screen or take away any PCBs attached to it.

#### 4.1.1 Description of touch screen



Picture 4-1: Description of Touch Screen

A: Display

B: Touch panel

#### 4.1.2 Touch panel appear error

Table 4-1: Touch Panel Information

LED indicator light	State
Green (light)	Work well
Orange (light)	Backlight lamp burning
Orange (shine)	During software startup
Red (light)	Power status
No shine	Power break off

### 4.1.3 Screen operation flow Table

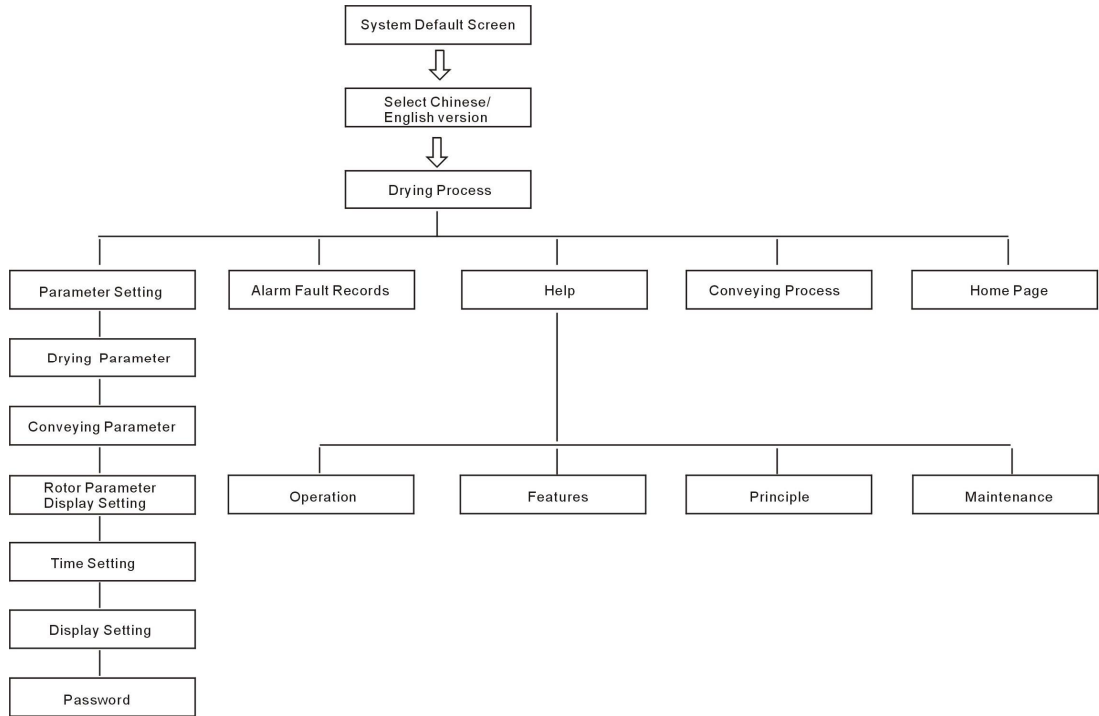

Picture 4-2: Screen Operation Flow Table

### 4.1.4 Menu Particular

#### 4.1.4.1 System Default Screen

When the system is connected with power source, the initial default screen will display as shown below. By touching the button of "English" or "Chinese" to select either English or Chinese language in order to login "Drying Process" screen.

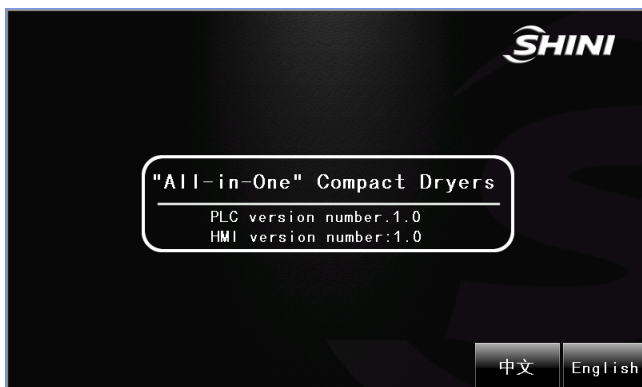

Picture 4-3: System Initial Screen

#### 4.1.4.2 Dehumidifying Process



Picture 4-4: Dehumidifying Process Screen

#### 4.1.4.3 Password Unlock

- 1) Input user name: shini
- 2) Input password: 3588
- 3) Press “Unlock”
- 4) Press “Return”, finish unlocking.

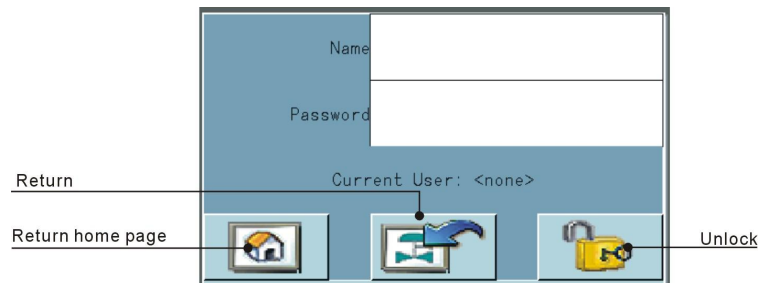

Picture 4-5: Password Input Screen

Note: Administrator password: 3333, Name: shiniwx,

Press  in dehumidifying control screen to enter drying monitor screen.



Picture 4-6: Drying Process

Press parameter setting button  in dehumidifying process screen to enter parameter settings menu screen.



Picture 4-7: Parameter Setting Menu Screen

When using weekly-timer mode, press weekly-timer function button  to enter weekly-timer screen and set one-week timer function.

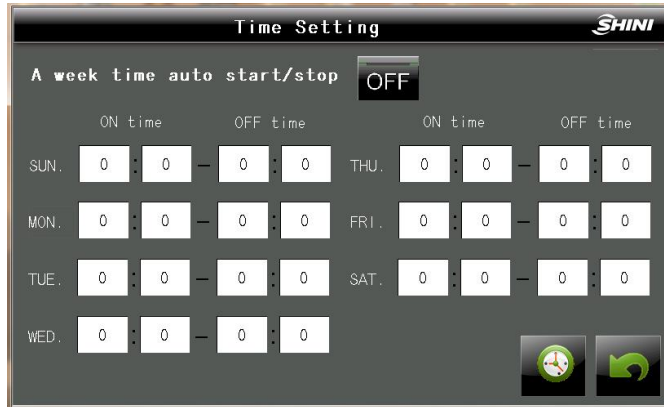

Picture 4-8: Time Setting Screen

Press parameter settings button  to enter parameter setting screen.

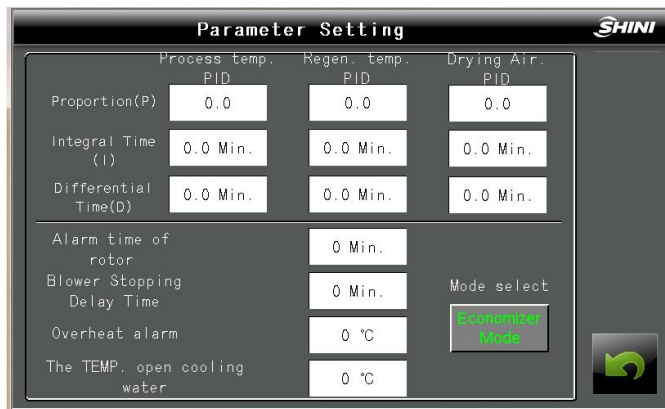

Picture 4-9: Parameter Setting

**Rotor alarm time:** Used to detect whether honeycomb rotor is rotating. Factory setting is 10min.

**Blower stop delay time:** When turning off the machine, blower's stop will be delayed to cool down the heat inside heater box to prevent the temperature inside the box keeps rising after machine's turning off. Factory setting is 3min.

**Overheat alarm:** Used for protection by preventing the system temperature rise beyond the temperature range. Factory setting is 15°C.

**Cooling water temperature setting:** Cooling water is used when the temperature is above the set temperature. Factory setting is 60°C.

#### 4.1.4.4 Working Modes of Regeneration Heater (Dehumidifying Function)

##### A. Regeneration Mode

##### Setting Steps:

1. Enter parameter setting screen, press mode button, choose regeneration mode.

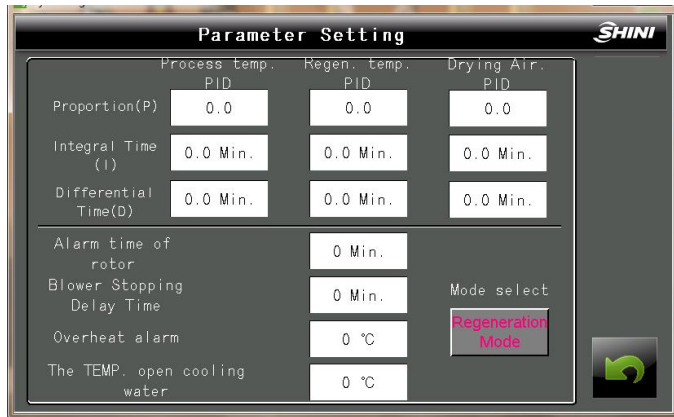

Picture 4-10: Parameter Setting Screen

2. Enter drying control screen, set material drying temperature and air volume.

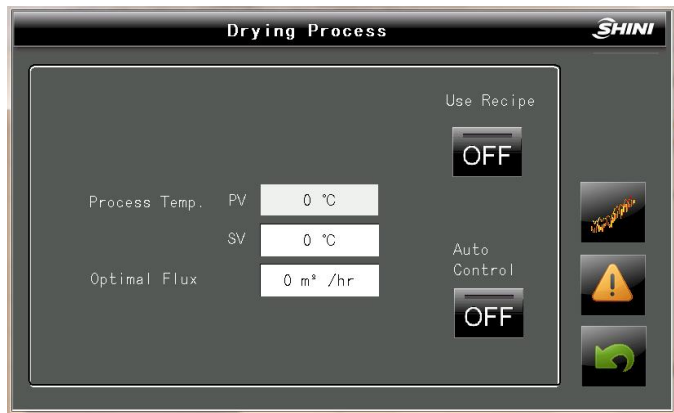

Picture 4-11: Drying Process Screen

3. Set regeneration temperature (180°C)

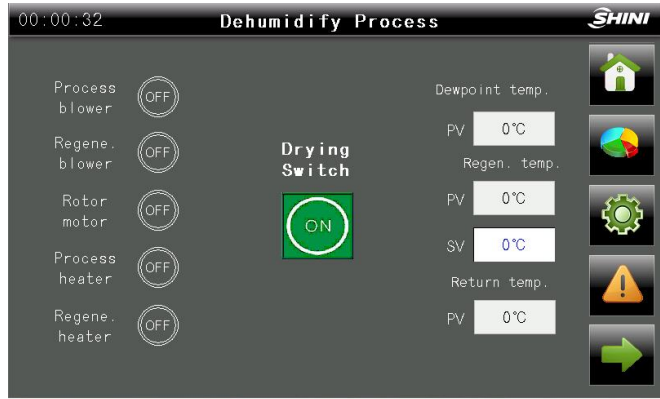

Picture 4-12: Dehumidify Process Screen

4. Press  button, machine will start-up.

Note: In this mode, regeneration temperature and drying air volume of the machine are constant. Machine will operate under a setting drying temperature, air volume and regeneration temperature.

### B. Energy saving mode

1. Enter parameter setting screen, press , choose energy saving mode.

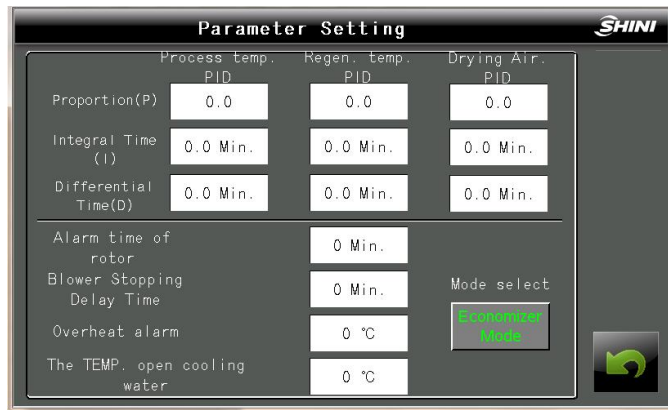

Picture 4-13: Parameter Setting Screen

2. Enter drying control screen, set material drying temperature and air volume.



Picture 4-14: Drying Process Screen

3. Set dew-point temperature



Picture 4-15: Dehumidify Process Screen

4. Press  button, machine will start up.

Note: In this mode, regeneration temperature (dehumidifying temperature) will be adjusted according to the change of dew-point temperature to saving energy



#### 4.1.4.5 Working Modes of Material Drying

##### A. Normal Drying Mode

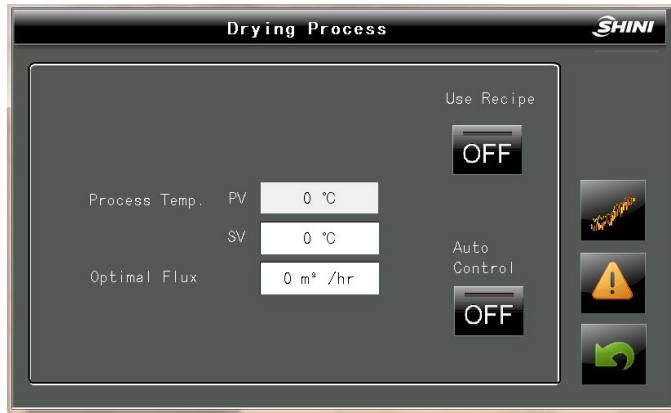

Picture 4-16: Drying Process Screen

Note: In this mode, only drying temperature and air volume need to be set. Machine will dry the material under a set temperature and air volume.

##### B. Activate Recipe-Drying Mode

1. Press **OFF** button,

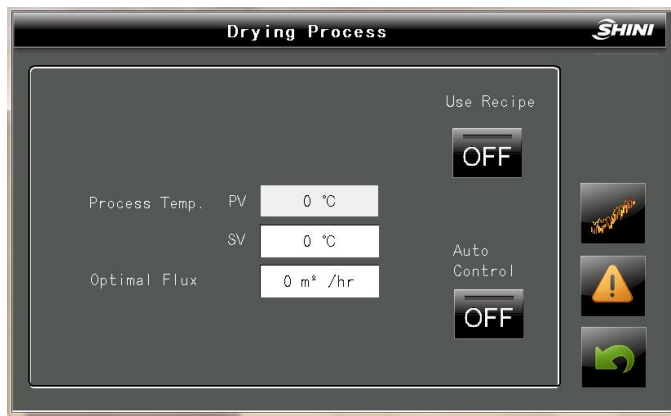

Picture 4-17: Drying Process Screen

## 2. Set Parameter of The Recipe

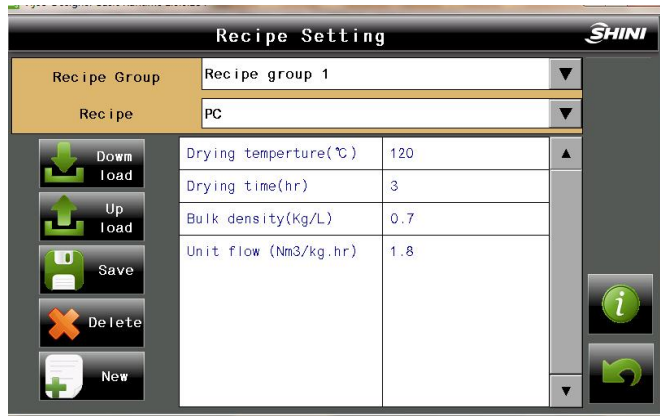

Picture 4-18: Recipe Setting Screen

## 3. Drying Process screen

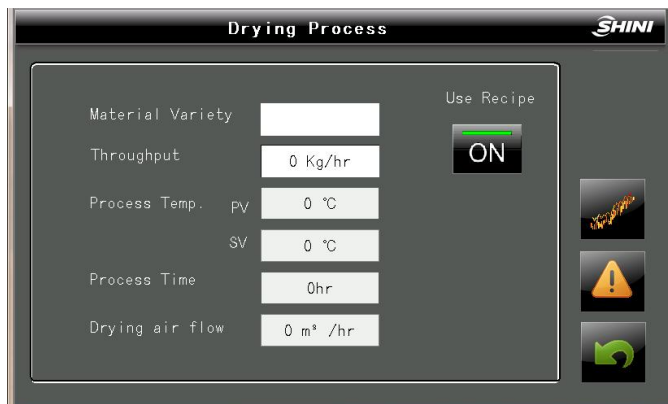

Picture 4-19: Drying Process Screen

Note: In this mode, drying air volume will change according to the throughput set in the recipe.

### C. Using return-air's temperature control mode

1. Press  to make it run.



Picture 4-20: Drying Process Screen

Set drying temperature and return-air temperature of the material as picture above.

Note: In this mode, drying air volume will adjust according to return-air's temperature to achieve energy saved controlling.

#### 4.1.4.6 Alarms Fault Records

Touch " Alarm Fault Records " button on the right of "Drying Process" screen or "Conveying Process" screen to enter into Alarm Fault Records screen. The screen is shown as below:



Picture 4-21: Alarm Fault Records

1. When alarm fault records cover more than displaying space, touch "Up" or "Down" keys to read more records.
2. According to the alarm information, the operator could get the troubleshooting information from the instruction book.
3. Press "EXIT" button to exit from this screen.

Table 4-2: Alarm Information List

Alert message	Range	Results	Possible causes
Anti-phase	SCD,SDD SD-H	System cannot operate, and the visible alarm is flickering.	Low voltage, anti-phase
Process blower overload.	SCD,SDD SD-H	Dehumidifier does not work and the visible alarm is flickering.	Incorrect motor overload setting, or motor burns out.
Regenerating blower overload.	SCD,SDD SD-H	Dehumidifier does not work and red alert light is flickering.	Incorrect motor overload setting, or motor burns out.
Conveying blower overload.	SCD	Material conveying stops and the visible alarm is flickering.	Incorrect motor overload setting, or motor burns out.
No.1 receiver suction problem	SCD	No.1 receiver stop suction function and the visible alarm is flickering.	Storage tank lacks material, suction probe problem, parameter wrongly setting, shut-off valve damaged.
No.2 receiver suction problem	SCD	No.2 receiver stop suction function and the visible alarm is flickering.	Drying hopper lacks material, suction box problem, parameter wrongly set, shut-off valve damaged.
No.3 receiver suction problem	SCD	No.3 receiver stop suction function and the visible alarm is flickering.	Drying hopper lacks material, suction box problem, parameter wrongly set, shut-off valve damaged
Process temperature overheat	SDD,SCD	Dehumidifier does not work and the visible alarm is flickering.	Temperature control parameter wrongly setup, touching pad is malfunction, process heating problem.
Regenerating temp.overheat	SCD,SDD SD-H	Alarm display on screen	1. Temperature control parameter set envi 2. Contactor fail 3. Thermocouple fail
Temp. overheat	SCD,SDD SD-H	Message display screen	No water supply or high water temperature.
Process temp. Thermople broken	SDD,SCD	Dehumidifier does not work and the visible alarm is flickering.	Thermocouple disconnected or bad contact.
Regenerating temp. Thermocouple broken	SCD,SDD SD-H	Dehumidifier does not work and the visible alarm is flickering.	Thermocouple disconnected or bad contact.
Rotor is not working	SCD,SDD SD-H	Dehumidifier stop and the visible alarm is flickering.	Rotor driving motor burnt, belt broken, micro switch fail, or incorrect rotor speed monitoring parameter setting.
PLC is not under operation mode	SCD,SDD SD-H	System stops.	PLC work mode is not in RUN mode.

- Note: 1) Overload Relay reset: Open control box, press "RESET" button on the corresponding overload relay.  
 2) Rotor Failure Alarm reset: Turn off the Drying Switch and then turn it "ON" again.  
 3) Over Temperature Alarm reset: Turn off the Drying Switch and then turn it "ON" again after the temperature drops down.

## 5. Trouble-shooting

Symptom	Possible causes	Actions taken
Alarm light for high dew point	1. Return air temperature too high	1. Check cooling water temperature (below 40°C)
	2. Abnormal setting of regenerating temperature	2. Set the regenerating temperature again(Default value H5 is 180°C, H4 is 150°C)
	3. Rotation wheel blocked	3. Clean or wash rotor
	4. Filter is blocked	4. Clean or replacement
	5. Leakage of heat-resistant hose	5. Check pipe and connector
	6. Operating time is less than 30 minutes	6. Wait until 30 minutes later for confirmation
	7. Rotation wheel is not working	7. Check motor, micro switch, belt is damage or not
	8. Motor's direction is wrong	8. Check motor's direction
	9. System drying capacity insufficient	9. Replace with a large system
	10. Honey-comb upper/lower lid is leaking	10. service or change the seal components
System cannot operate	1. Main AC power supply unconnected	1. Close main AC power supply
	2. Put timer switch into ON status	2. Reset timer button and restart again
	3. Motor overload or Phase reverse	3. Check close-loop, regenerative motor and AC power source are connected correctly
Lack material for a long time but suction blower don't work	1. Main AC power source unconnected or conveying is not in ON position	1. Turn on main AC power source
	2. Photo sensor, micro switch are bad contact	2. Adjust or replace
	3. Signal cable is broken	3. Re-connect or replace
Motor does not run	1. Heat relay off load	1. Check reason and reset
	2. Connector is not working	2. Check it is burnt out or not
	3. Power source lack of phase or motor is burnt out	3. Check and replace
Material is full but suction blower still working	1. Photo sensor or micro switch is On status	1. Adjust or replace
	2. Signal's cable is broken	2. Check signal cable
	3. Mechanical problem or contactor fail	3. Repair or Replace
	4. PLC problem	4. Check and replace

<b>Symptom</b>	<b>Possible causes</b>	<b>Actions taken</b>
Continuous running but cannot fill up hopper receiver	1. Material is empty	1. To add more materials
	2. Pipe leakage	2. Repair or replace
	3. Filter is blocked	3. Clean
	4. Diaphragm valve or shutoff valve is closed	4. Check diaphragm valve or shutoff valve's pressure, electric valve may be burnt out, circuit is well connected or not
	5. Blower blade problem	5. Check and repair

## 6. Maintenance and Repair

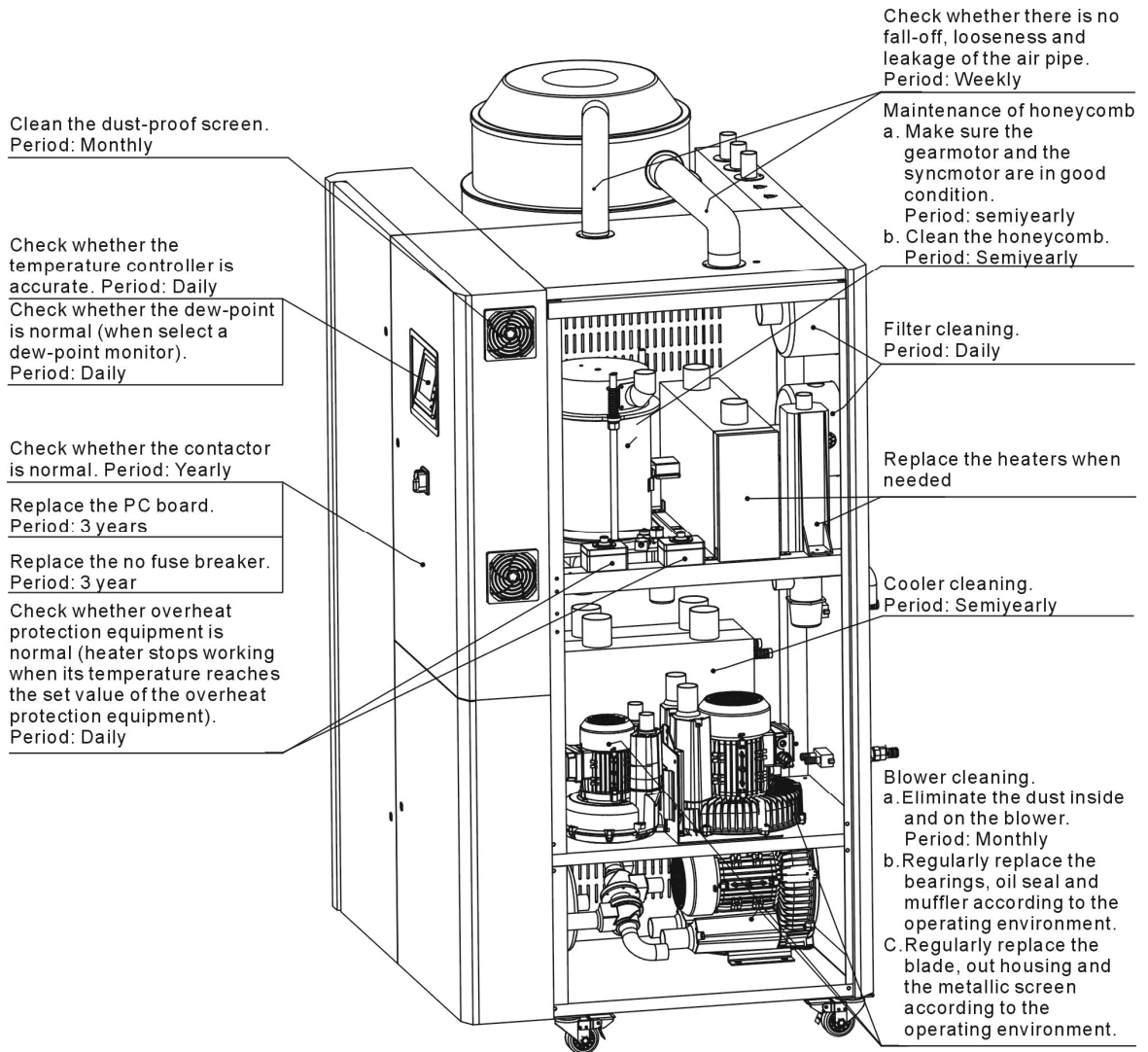

## 6.1 Filter & Pressure Regulating Valve

### 6.1.1 Filter & Pressure Regulating Valve Drawing

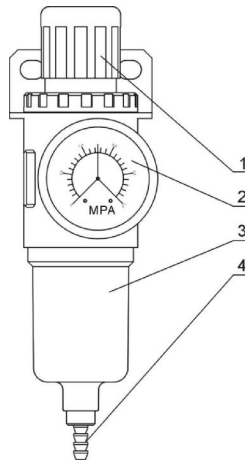

Parts list:

1. Pressure adjusting knob    2. Pressure gauge    3. Cup    4. Water outlet

Picture 6-1: Filter & Pressure regulating valve drawing

### 6.1.2 Filter & Pressure Regulating Valve Operation steps

- 1) Switch on the air source.
- 2) Pull the black pressure adjusting knob 1 upward and rotate it, observe the pressure gauge 2, generally a 0.5 Mpa pressure is advisable.
- 3) Push back the black knob 1.

## 6.2 Air Filters

Please periodically clean the dust on the air filters, once per week.

Cleaning steps:

- 1) Take out the air filter carefully.
- 2) Blow off the dust on the air filter screen and the cover with pressure air.
- 3) Wipe off the barrel wall of air filter with cloth.
- 4) After cleaning, place all parts in reversed order carefully.
- 5) Please ensure that the filter is well seal with metal frame.





Picture 6-2: Air filters



Note!

Don't let foreign object enter into the barrel, when taking out the air filter.

## 6.3 Blower Motors

### 6.3.1 Drying Blower

- 1) Fix inlet/outlet flange of blower, and tighten 4 screws securely.
- 2) Connect the blower with electrical source.
- 3) Install the blower on the Machine frame.



Picture 6-3: Installation of blowers

### 6.3.2 Regeneration Blower

- 1) Fix inlet/outlet flange of blower, and tighten 4 screws securely.
- 2) Install the blower on the machine frame.
- 3) Connect the blower with electrical source.

### 6.3.3 Conveying Blower

- 1) Fix inlet/outlet flange of blower, and tighten 4 screws securely.
- 2) Connect the blower with electrical power source.
- 3) Install the blower on the machine frame.
- 4) Fix the three-way valve (See Figure. 1).
- 5) Install the solenoid valve, and then tighten 2 screws on the machine frame (See Figure. 2).



Picture 6-4: Conveying blower

### 6.3.4 Blower Cleaning

- 1) To clean blower both internal and external parts (especially the fan cooling path), by removing surface dust. If more dusts are accumulated, it will cause deficiency for ventilation, temperature rising up, blower power reduced, vibration increased and so it will cause machine broke down.
- 2) Ball bearing, oil seal and sound-proof are belonging to consumable parts and so it has a life period and requires regular replacement.



Picture 6-5: Blower motors

## 6.4 Heater Assemblies

- 1) Install the heating pipe in the heater.
- 2) Fix the heater into the housing. (See right picture)



**Warning!**

Hot surfaces could burn hands. Take care of high temperature!

This label should be stick to the shell of heater.



1



2

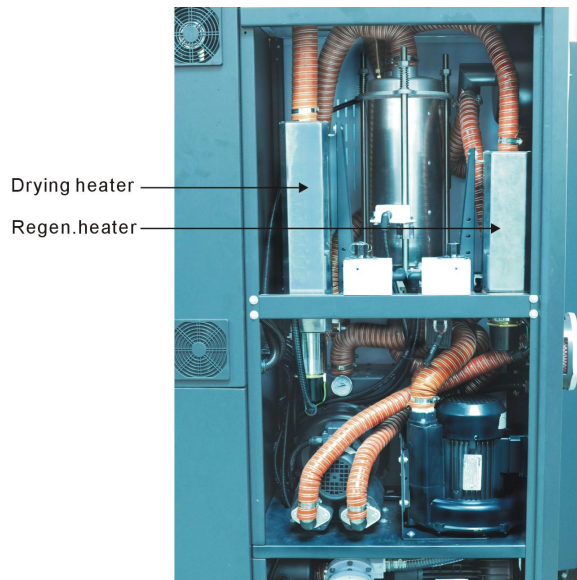

Picture 6-6: Heater assemblies

## 6.5 The Useful Life of the Key Parts of the Product

Table 6-1: The useful life of the key parts of the product

Name of the parts	Useful life
Blower	Above 5 years
Process heater	Above 1 year
Regen. herter	Above 1 year
Contactora	Above 2000,000 act
Honeycomb	5 years
Filter	1 year

## 6.6 Honeycomb-rotor

### 6.6.1 What is Honeycomb-rotor

The main body of the honeycomb-rotor is a honeycomb, made by ceramic fibre and organic additives, sintered under high temperature with molecular sieve and silica gel, to be strongly bonded together and form a solid and hard surface. Not like common molecular sieve, which will produce dusts and fines to pollute raw materials when aging or become saturated requiring regular replacement, the moisture of return air is quickly absorbed by numerous tunnels before coming out of the rotor to form low dew-point air. At the same time, regenerating blower takes dry air into the honeycomb-rotor from an opposite direction to regenerate the rotor.

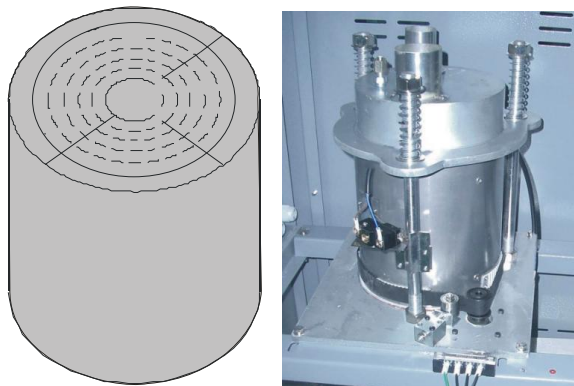

Picture 6-7: Honeycomb rotor

### 6.6.2 Installation of the Rotor

- 1) The upper and lower lid of honey-comb should install Teflon gasket (Fig. 1).
- 2) Use 4 screws to fix the rotor base on the machine frame firmly, and then install the shaft accordingly (Fig. 2).
- 3) Install the gearmotor and transmission gear (Fig. 4).
- 4) Install and fix the main support screws (Fig. 3).
- 5) Fit the transmission belt in proper position (Fig. 6).
- 6) Install the honeycomb-rotor (Fig. 9) and transmission belt (Fig. 12).
- 7) Fix the rotor top cover (Fig. 8).
- 8) Fit all springs and tighten the screws (Fig. 7).
- 9) Install both the transmission belt (Fig. 13) and belt tension regulator (Fig. 14).
- 10) Install micro-switch and fixed board firmly (Fig. 10).



Picture 6-8: Installation of the rotor

Honeycomb Rotor cleaning steps:

- 1) Use a vacuum-cleaner with brush to suck up the dust on rotor surface.
- 2) Blow off the dust in the rotor channels with compressed air.
- 3) If there is dirt sticking to the channel walls inside the rotor, cleaning steps as follows:
  - a. Saturate the rotor by blowing humid air (higher than 60%RH) through the rotor without having regeneration circuit on. This can be done by just turning the regeneration heater off and still have the process blower running if process air has high humidity. If the process air is too dry try to put a humidifier in the air stream. Do this for one hour.
  - b. Depending on the character of the dirt, sink the rotor into water with cleaning agent in it (PH value 3~2 liquid is applied to silica gel, PH value 7~10 applied to molecular valve). Greasy dirt should be put into a detergent solution with xylene. 15 minutes cleaning is suggested.
  - c. Take the rotor out of the liquid and let it rest with the channels vertically for 5 minutes so the liquid can run out.

- d. Blow off the residual liquid in the channels with compressed air.
- e. Put the rotor back into the dehumidifier and run the unit with regeneration circuit (the regeneration temperature between 50°C and 60°C) on for at least one hour.



Note:

- 1. Note that in the dry air and wet air outlets, there will be high concentrations liquid out for some time. If a solvent has been used, there will be a residual smell for several days.
- 2. For some dirt which is greasy and sticky in the rotor, 100% elimination is impossible. The only one thing you can do is to replace the rotor for the cleaned rotor performance can only be recovered partly.

## 6.7 EGO



The EGO value has been setting before out factory, Don't modify it.

	Default Value
Drying	200°C
Regenerating	200°C



Picture 6-9: EGO

## 6.8 Cooler

- 1) Clean the cooler and eliminate the leakage regularly.
- 2) Please do the above-mentioned job once a month for cooling by chilled water.  
As for the cooling by normal water, do the same job once a quarter.

### Cooler clear step

- 1) Disassemble the cooler's pipe and screw, and remove the cooler out of the chiller.
- 2) Release the fixed screw on the upper and lower cover of cooler and disassemble the cover.
- 3) Use brushes, compressed air or low pressure water to clean the dust and sundries on the cooler fan and copper pipe.

Notes: water residue on the cooler fan and copper pipe should be dried with compressed air.

- 4) Make the cooler's upper and lower cover junction clean enough and smear the silica gel then fixed the covers with screws.
- 5) Put the cooler on the air at least 4 hours to make the silica gel drying enough then fix the cooler on the chiller and connect all pipes.

## 6.9 Dewpoint Monitor(Optional)

### 6.9.1 Installation for Dewpoint Monitor

- 1) Cut off the film on control panel. Slightly cut it with the blade as there reserved with the holes.



Picture 6-10: Hole site

- 2) Check if there are complete parts for dewpoint monitor including:

Dew-point monitor

Dew-point transmitter assembly (dew-point detector, detection cable, washer and installation guide)

Copper joint, installation seat for dew-point monitor



Picture 6-11: Parts of dew-point monitor

- 3) Remove the dew-point detector assembly from the machine, and mount it to another  $\Phi 28$  hole on the controller. Install a dew-point monitor base on original hole, and mount two Teflon pipe connectors on the base. Via the copper pipe, one connector connects to the honeycomb and another connects to the dew-point detector assembly.



Picture 6-12: Copper joint assembly of original machine

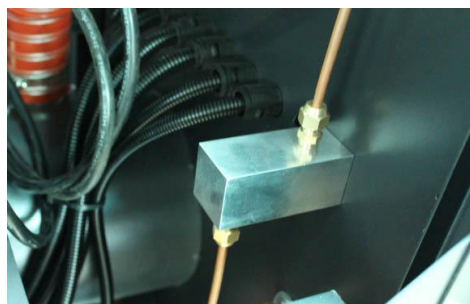

Picture 6-13: Installation seat



4) Install dew-point transmitter assembly to copper joint.

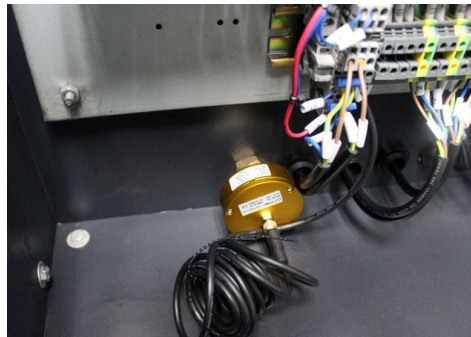

Picture 6-14: Installation for transmitter

5) Insert the dew-point monitor into the hole on the panel and fasten it.

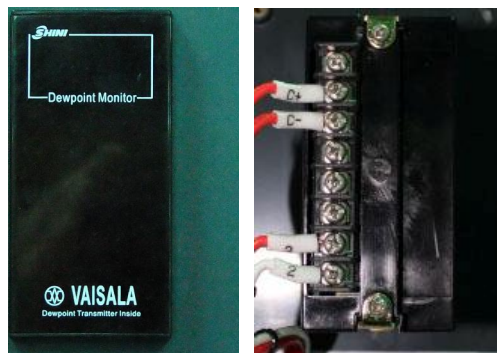

Picture 6-15: Connection of signal wire

6) Connect signal wires of the transmitter and power lines of dew-point monitor with the according terminals.

Connect contact No.1 and No.2 with power, supply is 220VAC.

Contact No.3, No.4 and No.5 are idle.

Connect contact No.6 and No.7 with the signal of transmitter. (C- Connects contact No.6, C+ connects contact No.7

Dew-point transducer wiring (white connect to C-, blue connect to C+)

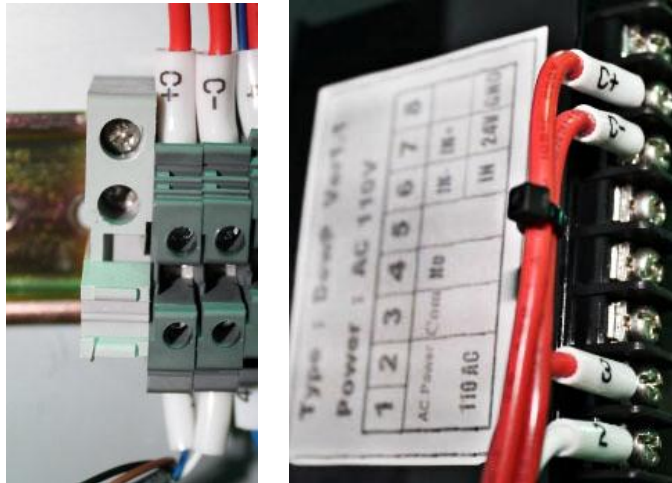

Picture 6-16: Connection of dew-point monitor

### 6.9.2 Dew-point monitor setting

#### 1. Common mode functional setting (adjust dew-point alarm setting value):

- 1) Press “S” key to enter setting (after entering, the displayer flickers);
- 2) Adjust dew-point alarm setting value, and press “U” and “D” to adjust the value.
- 3) Press “E” and save setting value.
- 4) Press “S” to leave setting mode.

#### 2. Special mode functional setting:

Enter this mode. Firstly hold “U” “D” for three secs. and enter (after enter special mode, it displays F-X in which X means that different number.);

Menu functions:

F-3: °C or °F in unit

F-5: it is +20°C when input 20 ampere

F-6: it's in min. temp. when signal input is 4 ampere. For example, if the measuring range of dew-point transmitter is -60~+20°C (this range always marks on the transmitter), therefore F-6 should be -60°C, F-5 should be +20°C.

F-7: the upper limit value (99-99)

F-8: the lower limit value (99-99)

## 6.10 Maintenance Schedule

### 6.10.1 General Machine Information

Model \_\_\_\_\_ SN \_\_\_\_\_ Manufacture date \_\_\_\_\_

Voltage \_\_\_\_\_  $\Phi$  \_\_\_\_\_ V Frequency \_\_\_\_\_ Hz Power \_\_\_\_\_ kW

### 6.10.2 Installation & Inspection

- Check if the air pipe are tightly connected.
- Check if the material clearance door tightly closed.
- Check if the air pipes are correctly connected.
- Check if there are damages of the honeycomb.

#### Inspection of electric components

- Voltage \_\_\_\_\_ V \_\_\_\_\_ Hz
- Fuse melt current: 1 Phase \_\_\_\_\_ A 3 Phases \_\_\_\_\_ A
- Check phase sequence of the power supply.
- Check the rotating direction of regeneration blower.
- Check the rotating direction of conveying blower.

#### Check air supply of compressor

- Compressed air pressure \_\_\_\_\_ bar
- Air flow \_\_\_\_\_ L/min
- Check if the compressed air purified or not

### 6.10.3 Daily Checking

- Check the switch of the machine.
- Check auto start-up of the machine.
- Check the temperature controller.
- Clean the filter.
- Check whether overheat protection is normal.
- Check whether dew-point is normal.

### 6.10.4 Weekly Checking

- Check all the electric wires.

- Check loose electric connections.
- Check and clean compressed air filter and regulator.
- Check magnetic valve.
- Check motor overload relay and phase-reversed prevention function.
- Check whether air pipe is shed, leaked and loose.

#### 6.10.5 Monthly Checking

- Check if the belt is loose or not.
- Check gear box working conditions.
- Check if there are leakages in the honeycomb.

#### 6.10.6 Half-yearly Checking

- Check if hot air pipe is broken or not.
- Check dehumidifier heater.
- Check regulation blower/material conveying blower/fans.
- Check whether honey-comb rotor belt is damaged.
- Clean the cooler.

#### 6.10.7 Yearly Checking

- Check whether the contactor is normal <sup>1</sup>.

#### 6.10.8 3 year Checking

- PC board renewal.
- No fuse breaker renewal.

Note: 1. Manufacturer laboratory data for AC contactor is two million times in life. we suggest service life for one million four hundred thousand times, if work eight hours per day, recommended replacing frequency is 1.5 years, if work day and night, replacement is suggested to be done every six months.