

44	YW66102500000	Flat washer 10x25x15 Longzine	1	29	YW65012000000	Standard spring washer GB/193 12-L-Longzine	65Mn	1	14	--	Control box assembly	Assembly	1	
43	YW64080600000	Hex. nut GB/16170 M8-Longzine	4	28	YW68005500000	Hexagon socket set screw with flat end GB/17065-Longzine	45H	1	13	YW61081600000	Inner hex cylindrical head screw GB/1701 M8X16-12.9-Longzine	12.9	4	
42	YW66102500000	Flat washer 10x25x15 Longzine	4	27	BH1124.1000010	Screw lock screw nut	4	1	12	YW03000300000	Brake castor 3"	Assembly	1	
41	BP82162100044	Filter cloth bag	Nylon mesh 400	26	--	Support foot 2	Q235A&SPH6.0	1	11	YW03000300300	Fixed castor 3"	Assembly	2	
40	YW64012100000	Hex. nut GB/16170 M12	4	25	--	Support foot 1	Q235A&SPH6.0	3	10	YW64080100000	Non-metal insert hex lock nut GB/1889.1 M8	5	16	
39	YW62041000000	Large cross recessed flat head screw 25T19M12-Longzine	4.8	24	--	Storage case assembly	Assembly	1	9	YW66081900000	Flat washer 8x19x2.0 Longzine	14.0HV	21	
38	YW02003000400	Snap hook	Assembly	23	--	Storage hopper assembly	Assembly	1	8	YW65008000100	Standard spring washer GB/193 8-Longzine	65Mn	4	
37	YW61102500000	Inner hex. flat head screw@TULI/M20-12.9-Longzine	12.9	22	--	Storage case assembly	Assembly	1	7	YW60082500100	Inner hex. ball GB/15183 M8X25-12.9-Longzine	4.8	16	
36	BH10162804.110	Limit block sleeve	Q235A	21	YW61062000200	Inner hex cylindrical head screw@TULI/M20-12.9-Longzine	12.9	4	6	--	Rack assembly	Assembly	1	
35	YW61083000000	Inner hex column head screw@TULI/M20-12.9-Longzine	12.9	20	YR40162800000	Rubber sleeve	PP	1	5	--	Screen bracket assembly	Assembly	1	
34	--	Limit block	SPH8.0	19	YW65010000000	Standard spring washer GB/193 10-Longzine	65Mn	7	4	YW60128000000	Hex. bolt GB/15182 M12x80-Longzine	8.8	1	
33	JT10001806000	Short click pulley wrench 8	Q235A	18	YW61102000000	Inner hex cylindrical head screw@TULI/M20-12.9-Longzine	12.9	4	3	BH10204208510	Feed box star assembly	Assembly	1	
32	YW62041000000	Large cross recessed flat head screw 25T19M12-Longzine	2	17	--	Gearing dentie	Assembly	1	2	--	Cutting chamber assembly	Assembly	1	
31	YW90351800100	Small ball thrust ball screws 3mm hole dia. 5mm hole distance 18mm		16	--	Storage hopper assembly	Assembly	1	1	--	Feed box assembly	Assembly	1	
30	YW661224.00000	Flat washer GB/193.12-Longzine	14.0HV	15	YW03000300200	Portable castor 3"	Assembly	1	No.	Code	Name	Mat.	Qty.	Remark

制图	版号	标题	图号	比例	数量
设计	核准	SG-1621N		1:1	1
校对		粉碎机总成		材质	
审核	日期	SHINI 信易電熱機械股份有限公司	表面要求		
标记	更改前	更改后	更改人	日期	物料号

SHINI 信易電熱機械股份有限公司
Shini Plastics Technologies, Inc.

Additional drawing

Standard weight (kg)	Cutting Noise(B (A))	Max. cutting ability (kg/hr)	Cutting Chamber Size (mm)	Rotating Blade Qty.	Fix Blade Qty.	Culter Mat.	Main shaft rotation(r.p.m)	Motor power (KW)	Version
175	80~85	35	160×210	9	2	SKD11	230	1.5	Ver.F

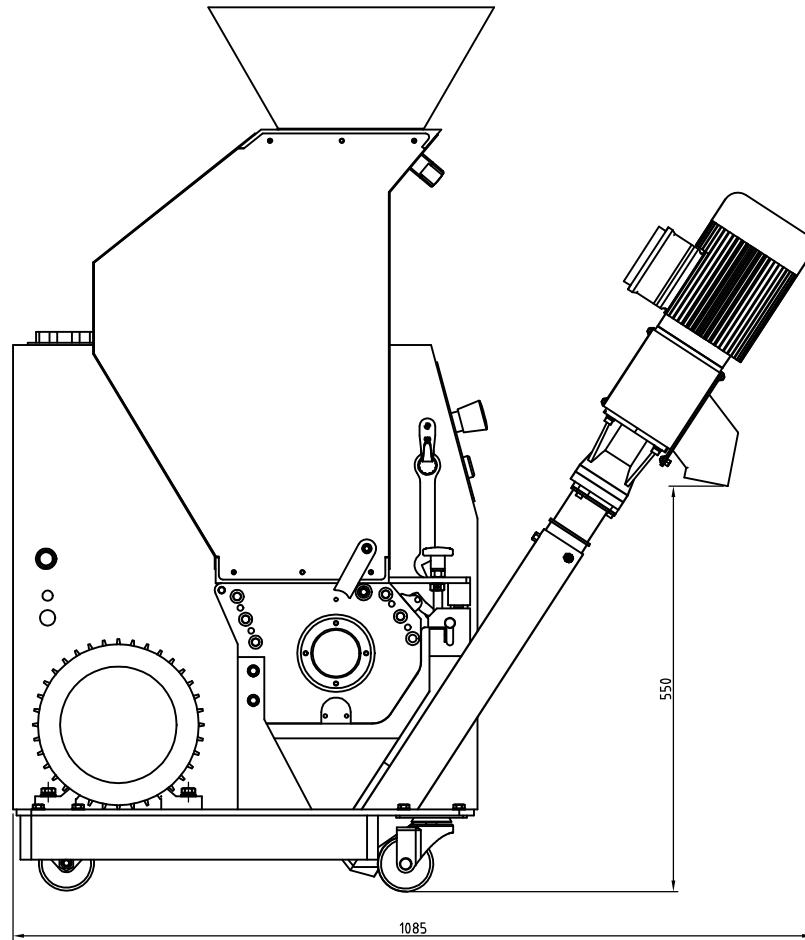

Optional spring conveyor

- Notes: 1) The max. cutting capacity depends on the material size and crushed material;
 2) The noise when granulating is different due to the configuration of crushed materials and motor.
 3) SKD11 Japan JIS standard;
 4) To avoid material sticking the blade, all materials to be crushed shall be crushed at normal temp.;
 5) Machine power: 3φ,400VAC,50Hz;

					制图	版号	标题	图号	比例	数量
					设计	核准	SG-1621N 粉碎机总成		表面要求	材质
					校对		信易電熱機械股份有限公司 Shini Plastics Technologies, Inc.			
标记	更改前	更改后	更改人	日期	审核	日期		物料号		

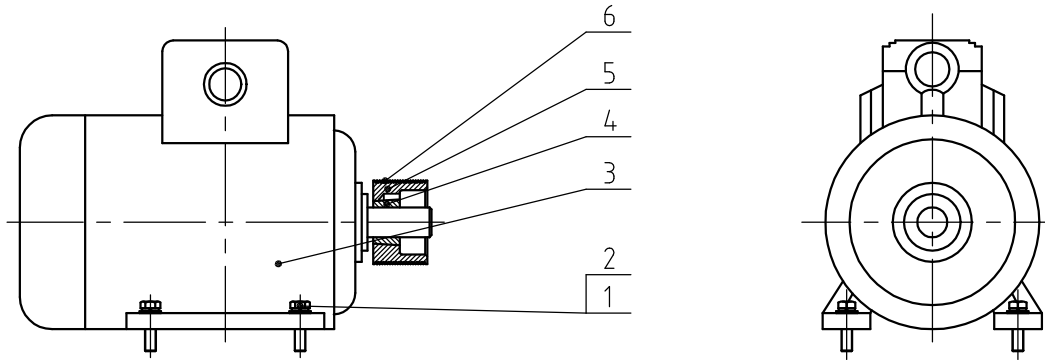

6	YW30205000000	Poly V-belt 20 PJ 50"		1	
5	BW30001605220	Small belt pulley SG-16-P20P J78-1210 HT250 (assembly)		1	
4	BW30001605420	Small taper sleeve SG-16-1210-28 HT250 (assembly)		1	
3	YM10201500500	Motor W20 15kW-100L-6P B3R IE3 230V/400V/460V		1	
2	YW65010000000	Standard spring washer GB/T93 10-Longzine	65Mn	4	
1	YW60103000200	Hex bolt GB/T5783 M10x30-8.8-Longzine		4	
No.	Material number	Name	Mat.	Num.	Remarks

					Draw.	Ver.	Title	Drawing no.	Scale	Num.
					Desi.	App.	Actuating Device			Mat.
					Check	by	SHINI 信易電熱機械股份有限公司 Shini Plastics Technologies, Inc.	Surface req.		
Mark	Before Mark	After Mod.	Modified by	Date	App.	Date		Mat No.		

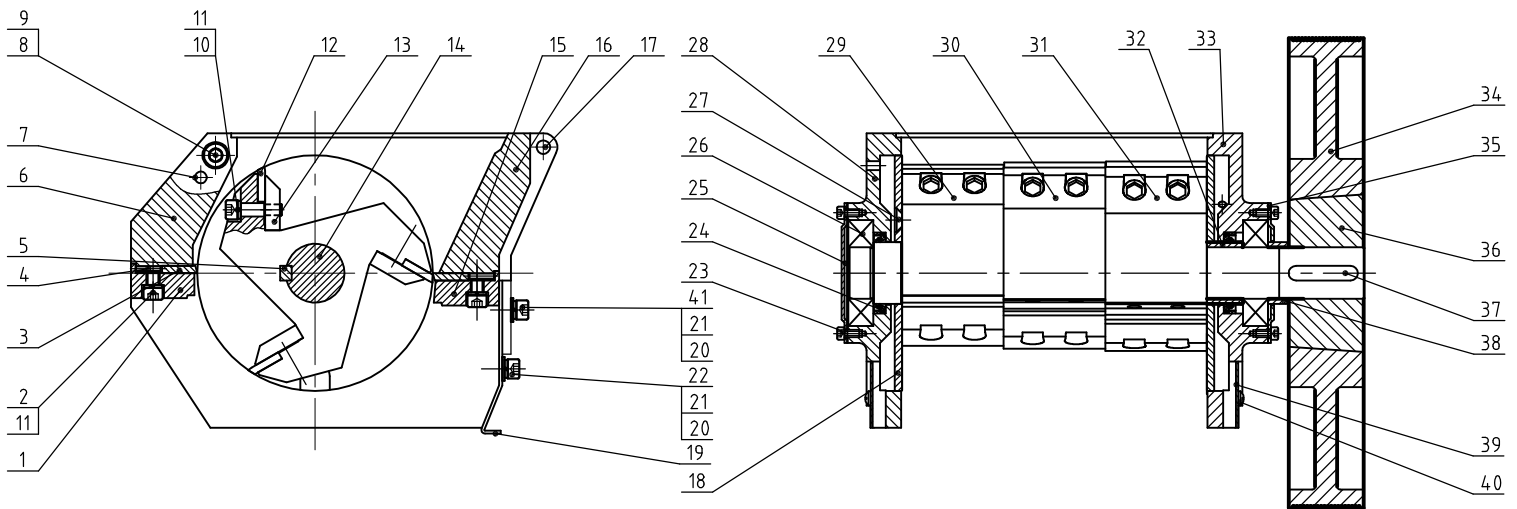

41	YW61082501200	Inner hex column head screw (QT/TU/INOS-D3-Longline)		2		20	YW61081600000	Large belt wheel SG-40-PP20-30(H20 Count)		2	
40	YW63050800000	Long recessed panel screw (BT-40/15-4-Longline)	4.8	4		19	--	Storage box hanging plate	SPCC2.0	1	
39	--	Over plate	SPCC1.5	2		18	YW45162850000	Fender plate	65Mn	2	
38	BH10162823010	Steel	Q235A	1		17	BH10204100010	Rotating shaft	Q235A	2	
37	BH1161400010	Flat key 10×8×4.6.5	45	1		16	BH10162600010	Rear box block	QT500-7	1	
36	BW30001605320	Big taper sleeve SG-16-30R-20(H20 Count)		1		15	BH10162500010	Rear box block pressing block	Q235A	1	
35	BL54162800020	Right bearing ext. over plate	SPCC2.0	1		14	BH55162100010	Main shaft	45	1	
34	BW30001605120	Large belt wheel SG-40-PP20-30(H20 Count)		1		13	BH11627000010	Lock blade	Q235A	9	
33	BW30162807010	Right end plate	QT500-7	1		12	YW42162840000	Rotating blade	SKD11	9	
32	BH10161500010	Sleeve	Q235A	1		11	YW65008000100	Standard spring washer GB/T93-B-Longline	65Mn	22	
31	BW30162111510	Blade rest(2)	QT500-7	1		10	YW61083000000	Inner hex column head screw (QT/TU/INOS-D3-Longline)		18	
30	BW30001612910	Blade rest(1)	QT500-7	1		9	YW65010000000	Standard spring washer GB/T93-B-Longline	65Mn	12	
29	BW30162811610	Blade rest(1)	QT500-7	1		8	YW61103500000	Inner hex column head screw (QT/TU/INOS-D3-Longline)		12	
28	BW30162807110	Left end plate	QT500-7	1		7	YW69083500000	Spring column pin GB/T 879.1 B-35	65Mn	8	
27	YW61082000100	Inner hex column head screw (QT/TU/INOS-D3-Longline)		6		6	BW30162105110	Front box block	QT500-7	1	
26	YW11620701800	Bearing 6207-2RS1		2	SKF	5	BH10162110010	Flat key 10×199	45	1	
25	BL54162830020	Left bearing ext. over plate	SPCC2.0	1		4	YW68051600000	Inner hex flat end lock screw (BT/17/16-6)	33H	4	
24	YR80554200000	Oil seal φ55×φ4.2×7		2		3	YW42162100000	Rotating blade	SKD11	2	
23	YW61051000000	Inner hex column head screw (QT/TU/INOS-D3-Longline)		8		2	YW61082501200	Inner hex column head screw (QT/TU/INOS-D3-Longline)		4	
22	YW66081900000	Flat washer A grade GB/T191-100-H-2-L-Longline	14.0HV	4		1	BH10162104010	Front box block pressing block	Q235A	1	
21	YW65008000100	Standard spring washer GB/T93-B-Longline	65Mn	4		No.	Material number	Name	Mat.	Num.	Remarks

Draw.	Ver.	Title	SG-1621N	Drawing no.	Scale	Num.
Desi.	App. by	Cutting Chamber Assembly			Mat.	
Check	by	信易電熱機械股份有限公司 Shini Plastics Technologies, Inc.			Surface req.	
Mark	Before Mod.	After Mod.	Modified by	Date	App.	Date
				Mat. No.		

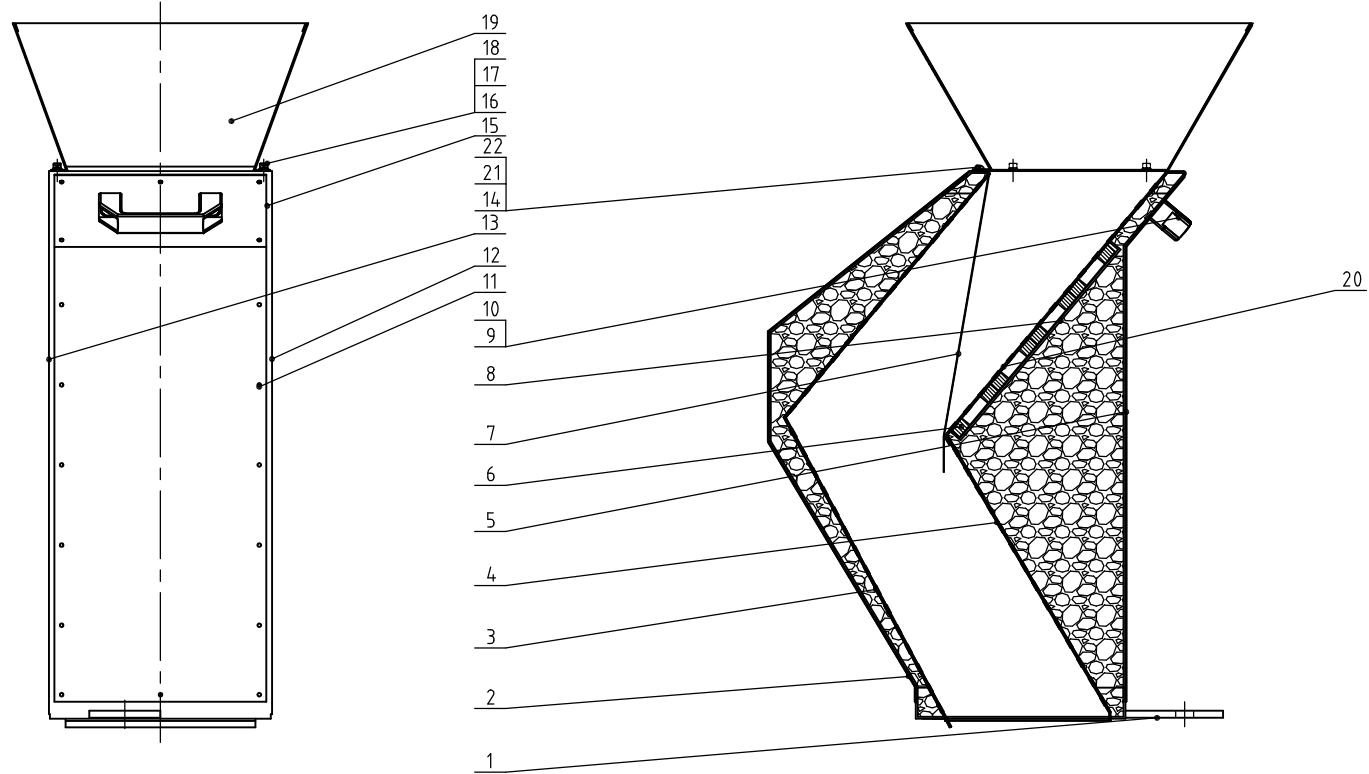

22	YW62051000100	Large recessed flat head screw JS 1111 M5X10-Longzine	12.9	3							
21	--	Fender plate pressing plate	SPCC1.5	1		10	YW61081600000	Inner hex. column head screw M16	12.9	2	
20	--	Front inner plate 2	SUS201 2.0	1		9	BW20012000140	Handle L. 120	Alum. alloy	1	
19	--	Feed part	SPCC1.5	1		8	--	Magnetic box	SPCC1.2	1	
18	YW66051000000	Flat washer 5	14.0HV	4		7	--	Fender plate	White water-proof cloth	1	
17	YW65005200000	Spring washer 5	65Mn	4		6	YW90683200000	Magnet 68×32×12		12	
16	YW61051000000	Inner hex. column head screw M5x10	12.9	4		5	--	Front guard plate	SPCC1.2	1	
15	--	Left & right inner plate	SECC2.0	2		4	--	Front inner plate 1	SECC2.0	1	
14	--	Hopper part	SPCC2.0	1		3	--	Rear inner plate	SECC2.0	1	
13	--	Left guard plate	SPCC1.2	1		2	--	Rear guard plate	SPCC1.2	1	
12	--	Right guard plate	SPCC1.2	1		1	--	Square base	SPCC2.0	1	
11	YW67481900000	Large recessed pan head laping screw S14.8×10		4.0		No.	Material number	Name	Mat.	Num.	Remarks

Draw.	Ver.	Title		Drawing no.		Scale	Num.
Desi.	App. by	Feed Box Assembly					Mat.
Check		偵易電熱機械股份有限公司 Shini Plastics Technologies, Inc.		Surface req.			
Mark	Date			Mat No.			
Before Mod.	After Mod.	Modified by.	Date	App.	Date		

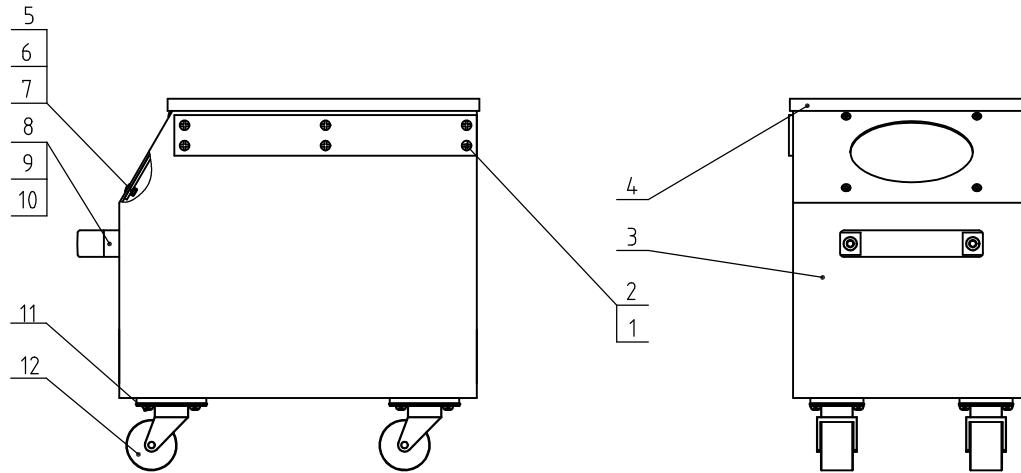

12	YW03000200000	Black castor 2"(De Shen)	Assembly	4	
11	YW62050500000	Large cross recessed flat head screw JS1111 M5×5	Longzine	16	
10	YW64000800100	Non-metal insert hex. lock nut GB/T889.1 M8Z	6	2	
9	YW61081600000	Inner hex. column head screw GB/T70.1 M8×16-12.9-Longzine	8.8	2	
8	BW2001200014.0	Square alu. handle L120(M8 hole)black	Alum. alloy	1	
7	YW64040700100	Non-metal insert hex. lock nut GB/T889.1 M4	5	4	
6	YW62041000000	Large cross flat head screw JS1111 M4×10-Longzine	8.8	4	
5	BR90242750050	Visual window transparent plate	Acrylic	1	
4	--	Storage box cover	SECC2.0	1	
3	--	Storage case	SECC2.0	1	
2	YW61040600000	Inner hex. countersunk screw GB/T70.3 M4×6-12.9-Longzine	8.8	12	
1	BR90162800310	Fender plate	Teflon	2	
No.	Material number	Name	Mat.	Num.	Remarks

					Draw.		Ver.	Title	SG-1621N	Drawing no.	Scale		Num.	
					Desi.		App.	Storage Box Assembly (option)			☐	☉	Mat.	
					Check		by	 信易電熱機械股份有限公司 Shini Plastics Technologies, Inc.			Surface req.			
Mark	Before Mark	After Mod.	Modified by.	Date	App.	Date				Mat No.				

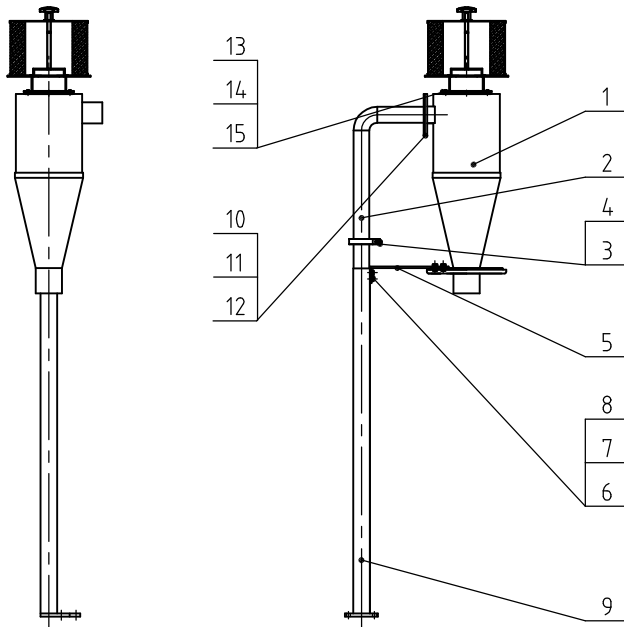

15	YW60512880000	Inner hex. bolt GB/15783 M5x12-8.8-Longzine		4	
14	S000000000357	Simple filter	Welding assembly	1	
13	BL59160000121	Filter	Welding assembly	1	
12	YW65008000100	Standard spring washer GB/193 8-Longzine		4	
11	YW66081900000	Flat washer 8x19x2.0 Longzine		4	
10	YW60081600100	Inner hex. bolt GB/15781 M6x16-4.8-Longzine		4	
9	--	Lower support	Welding assembly	1	
8	YW65005200000	Standard spring washer GB/193 5-Longzine	60Mn	2	
7	YW66051000000	Flat washer A grade GB/197.15-Longzine	14.0HV	6	
6	YW61050600300	Inner hex. column head screw GB/170.1M6x6-12.9-Longzine		4	
5	--	Support plate	SPH4	1	
4	YR20001500000	Food connector seal ring 1.5"		1	
3	YW07001500500	1.5" food connector pipe clamp		1	
2	S000000000620	Upper support	Welding assembly	1	
1	S000000000966	Cycloner	Welding assembly	1	
No.	Material number	Name	Mat.	Num.	Remarks

					Draw.		Ver.		Title	SG-16N/20N	Drawing no.	Scale	Num.
					Desi.		App.		BC Cyclone Support Rack (option)				Mat.
					Check		by		信易電熱機械股份有限公司 Shini Plastics Technologies, Inc.		Surface req.		
Mark	Before Mark	After Mod.	Modified by	Date	App.		Date					Mat No.	

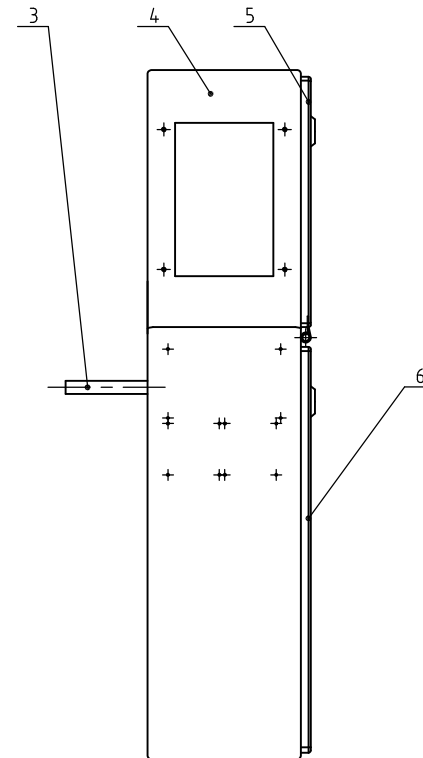
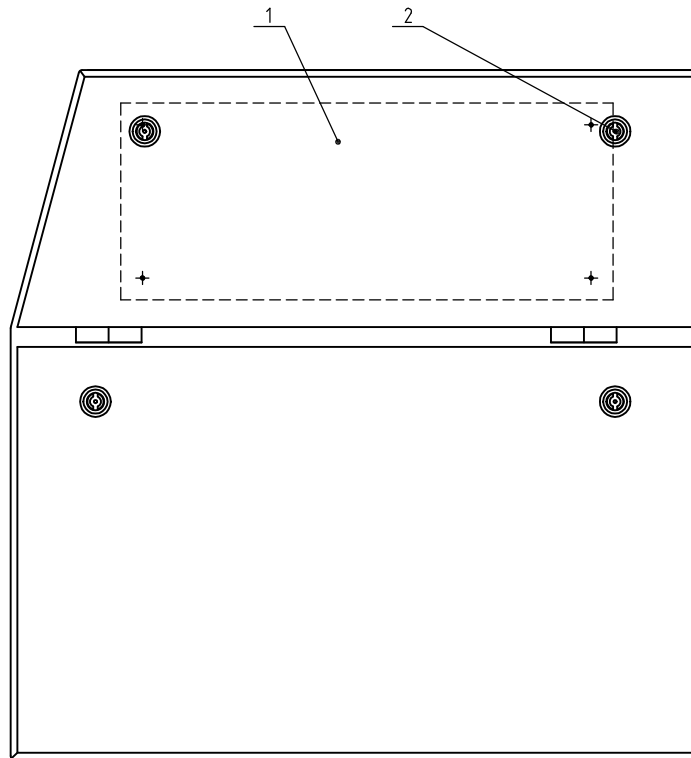

No.	Material number	Name	Mat.	Num.	Remarks
6	--	Shell lower cover plate	SPCC2.0	1	
5	--	Shell upper cover plate	SPCC2.0	1	
4	--	Shell	SPCC3.0	1	
3	--	Feed box support rod	Q235A	1	
2	YW00000000100	Long door lock		4	
1	--	Elec. mount plate	SPCC15	1	

Mark	Before Mod.	After Mod.	Modified by	Date	Draw	Ver.	App. by	Date

Title: SG-1621N/1628N/1635N		Drawing no.		Scale	Num.
Control box assembly				Mat.	
信易電熱機械股份有限公司 Shini Plastics Technologies, Inc.					Surface req.
				Mat No.	

Additional drawing

Standard weight (kg)	Noise during granulating dB(A)	Max. cutting ability(kg/hr)	Cutting chamber size (mm)	Rotating Blade Qty.	Fixed Blade Qty.	Cutter Blade	Max. shaft rotation(rpm)	Motor power(KW)	(Ver. No.)
195	80~85	50	160x280	12	2	SKD11	235	2.2	Ver.F

- Notes: 1) The max. cutting capacity depends on the material size and crushed material;
 2) The noise when granulating is different due to the configuration of crushed materials and motor.
 3) SKD11 Japan JIS standard;
 4) To avoid material sticking the blade, all materials to be crushed shall be crushed at normal temp.;
 5) Machine power: 3Ø,400VAC,50Hz;

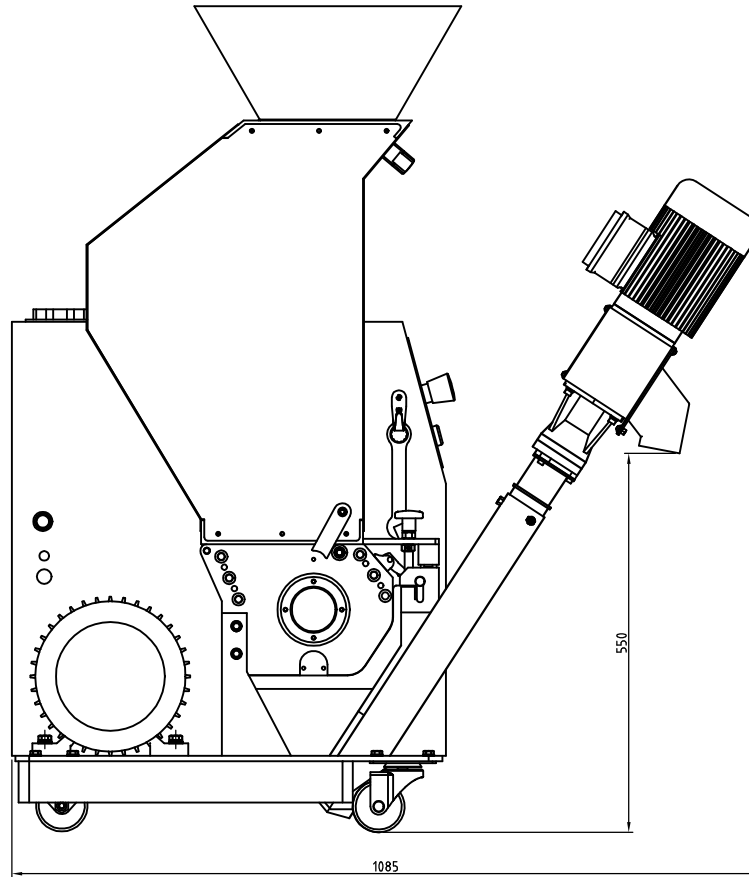

Optional spring conveyor

					制图		版号		标题	SG-1628N	图号		比例	数量
					设计		核		粉碎机总成				材质	
					校对		准		信易电热机械股份有限公司 Shini Plastics Technologies, Inc.			表面要求		
标记	更改前	更改后	更改人	日期	审核		日期			物料号				

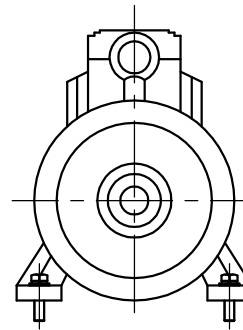
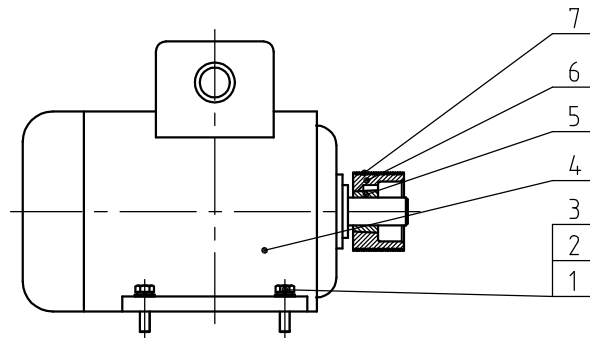

7	YW30205000000	Poly V-belt 20 PJ 50"		1	
6	BW30001605220	Small belt pulley SG-16-P20P178-12W HT250 (assembly)		1	
5	BW30001605420	Small taper sleeve SG-16-1210-28 HT250 (assembly)		1	
4	YM10202200500	Motor W20 2.2kW-112M-4P B3R IE3 230V/400V/460V		1	
3	YW66102500000	Flat washer 10x25x15-Longzine	14.0HV	4	
2	YW65010000000	Standard spring washer GB/T93 10-Longzine	65Mn	4	
1	YW60104000100	Hex bolt GB/T5783 M10x40-8.8-Longzine		4	
No.	Material number	Name	Mat.	Num.	Remarks

					Draw.		Ver.		Title	SG-1628N	Drawing no.	Scale	Num.
					Desi.		App.		Actuating Device				Mat.
					Check		by		信易電熱機械股份有限公司 Shini Plastics Technologies, Inc.		Surface req.		
Mark	Before Mark	After Mod.	Modified by	Date	App.		Date					Mat No.	

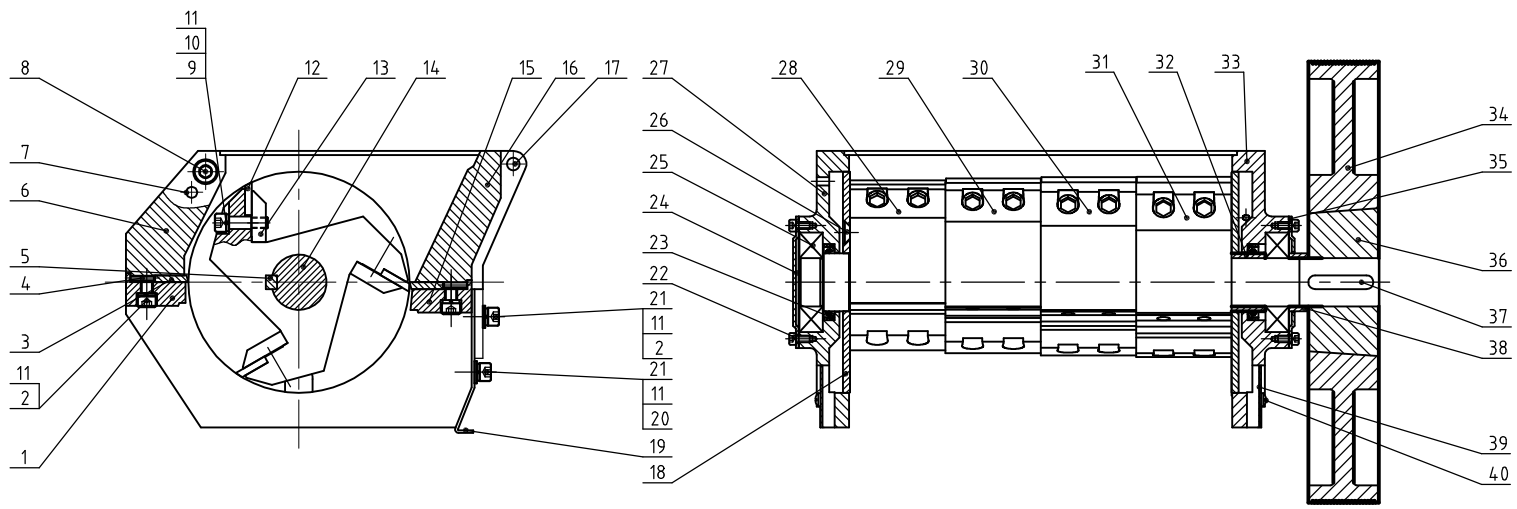

No.	Material number	Name	Mat.	Num.	Remarks
40	YW63050800000	Coax. recessed pan head screw Q17.00156-Longlife	4.8	4	
39	--	Clear plate	SPCC15	2	
38	BH10162823010	Steel 1	Q235A	1	
37	BH11161400010	Flat key 10x8x6.5	45	1	
36	BW30001605320	Big taper sleeve SC-303-25.H125(Lowalt)		1	
35	BL54.162800020	Large ball wheel SC-400-PP30-30.H125(Lowalt)	SPCC2.0	1	
34	BW30001605120	Large ball wheel SC-400-PP30-30.H125(Lowalt)		1	
33	BW30162807010	Right end plate	QT500-7	1	
32	BH10161500010	Sleeve	Q235A	1	
31	BW30162811710	Blade rest(2)	QT500-7	1	
30	BW30001613010	Blade rest 2	QT500-7	1	
29	BW30001612910	Blade rest1	QT500-7	1	
28	BW30162811610	Blade rest(1)	QT500-7	1	
27	BW30162807110	Left end plate	QT500-7	1	
26	YW61082000100	Inter hex column head screw Q17.00156-L2-Longlife		6	
25	YW11620701800	Bearing 6207-2RS1	2	SKF	
24	BL54.162830020	Left bearing end cover plate	SPCC2.0	1	
23	YR80554.2000000	Oil seal φ55×φ42×7		2	
22	YW61051000000	Inter hex column head screw Q17.00156-L2-Longlife		8	
21	YW66081900000	Flat washer A grade Q17.00156-L2-Longlife	14.0HV	4	
20	YW61081600000	Inter hex column head screw Q17.00156-L2-Longlife		2	
19	--	Storage box hanging plate	SPCC2.0	1	
18	YW45162850000	Fender plate	65Mn	2	
17	BH10204.1000010	Rolling shaft	Q235A	2	
16	BH10162900010	Rear box block	QT500-7	1	
15	BH10160280010	Rear box block pressing block	Q235A	1	
14	BH55162600010	Main shaft	45	1	
13	BH11627000010	Lock blade	Q235A	12	
12	YW4.216284.00000	Rolling blade	SKD11	12	
11	YW65008000100	Standard spring washer Q17.00156-L2-Longlife	65Mn	34	
10	YW61083000000	Inter hex column head screw Q17.00156-L2-Longlife		24	
9	YW65010000000	Standard spring washer Q17.00156-L2-Longlife	65Mn	12	
8	YW61103500000	Inter hex column head screw Q17.00156-L2-Longlife		12	
7	YW69083500000	Spring column pin GB/T 879.1-35	65Mn	8	
6	BW30162806110	Front box block	QT500-7	1	
5	BH10162810010	Flat key 10x268	45	1	
4	YW68051600000	Inter hex flat head screw Q17.00156-L2-Longlife	33H	4	
3	YW4.11628200000	Fixed blade	SKD11	2	
2	YW61082501200	Inter hex column head screw Q17.00156-L2-Longlife		8	
1	BH10162804.010	Front box block pressing block	Q235A	1	

Draw.	Ver.	Title	SG-1628N	Drawing no.	Scale	Num.
Desi.	App. by	Cutting Chamber Assembly				Mat.
Check	Date	信易電熱機械股份有限公司 Shini Plastics Technologies, Inc.		Surface req.		
Mark	Before Mod.	After Mod.	Modified by.	Date	Mat. No.	

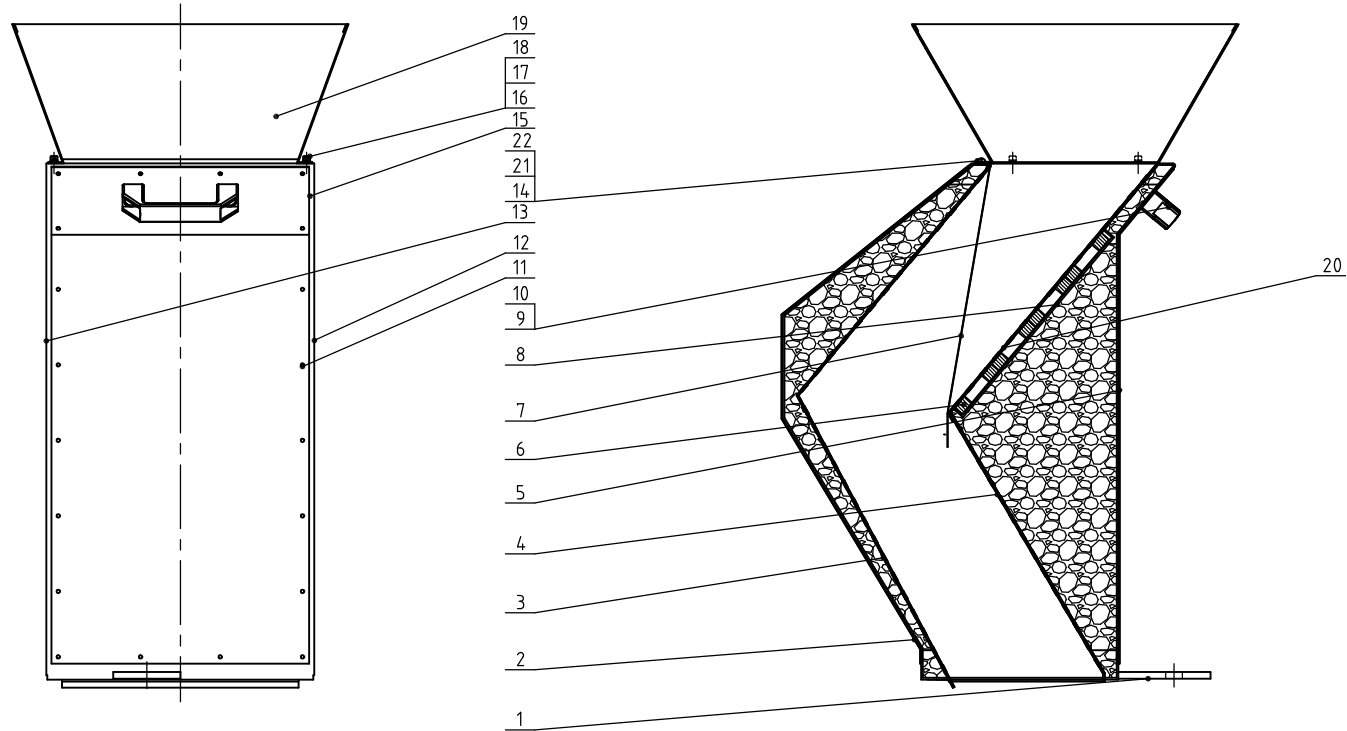

22	YW62051000100	Large recessed flat head screw JS 1111 MSX10-Longline	12.9	3									
21	--	Fender plate pressing plate	SPCC1.5	1		10	YW61081600000	Inner hex. column head screw M6x6	12.9	2			
20	--	Front inner plate-2	SUS201 2.0	1		9	BW20012000140	Handle L 120	Alum. alloy	1			
19	--	Feed part	SPCC1.5	1		8	--	Magnetic box	SUS201 1.2	1			
18	YW66051000000	Flat washer 5	14.0HV	4		7	--	Fender plate	White water-proof cloth	1			
17	YW65005200000	Spring washer 5	65Mn	4		6	YW90683200000	Magnet 68x32x12		16			
16	YW61051000000	Inner hex. column head screw M5x10	12.9	4		5	--	Front guard plate	SPCC1.2	1			
15	--	Left & right inner plate	SECC2.0	2		4	--	Front inner plate 1	SECC2.0	1			
14	--	Hopper part	SPCC2.0	1		3	--	Rear inner plate	SECC2.0	1			
13	--	Left guard plate	SPCC1.2	1		2	--	Rear guard plate	SPCC1.2	1			
12	--	Right guard plate	SPCC1.2	1		1	--	Square base	SPCC2.0	1			
11	YW67481900000	Large recessed pan head tapping screw S14.8 -D		4.4		No.	Material number	Name	Mat.	Num.	Remarks		

					Draw	Ver.	Title	Drawing no.	Scale	Num.
					Desi.	App.	SG-1628N		1:1	1
					Check		Feed Box Assembly			Mat.
Mark	Before Mod.	After Mod.	Modified by	Date	App.	Date	 信易電熱機械股份有限公司 Shini Plastics Technologies, Inc.		Surface req.	
									Mat No.	

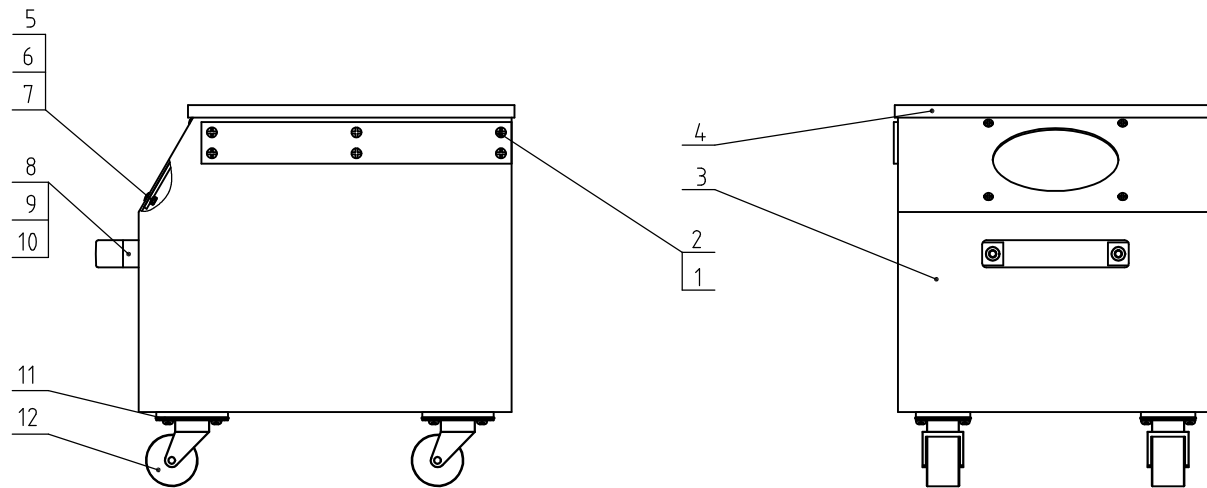

12	YW03000200000	Black castor 2'	Assembly	4	
11	YW62050500000	Large cross recessed flat head screw JS1111 M5x5	Longzine	16	
10	YW64000800100	Anti-loose nut M8		6	2
9	YW61081600000	Inner hex. nut M8x16		8.8	2
8	BW20012000140	Handle	Alum. alloy		1
7	YW64040700100	Anti-loose nut M4		5	4
6	YW62041000000	Large cross flat head screw JS1111 M4x10-Longzine		8.8	4
5	--	Visual window transparent plate	Acrylic		1
4	--	Storage box cover	SECC2.0		1
3	--	Storage case	SECC2.0		1
2	YW61040600000	Inner hex countersunk screw GB/T70.3 M4x6-12.9-Longzine		8.8	12
1	BR90162800310	Fender plate	Teflon		2
No.	Material number	Name	Mat.	Num.	Remarks

					Draw.		Ver.		Title	SG-1628N	Drawing no.			Num.	
					Desi.		App.		Storage Box Assembly (option)					Mat.	
					Check		by		 信易電熱機械股份有限公司 Shini Plastics Technologies, Inc.						
Mark	Before Mark	After Mod.	Modified by	Date	App.		Date								

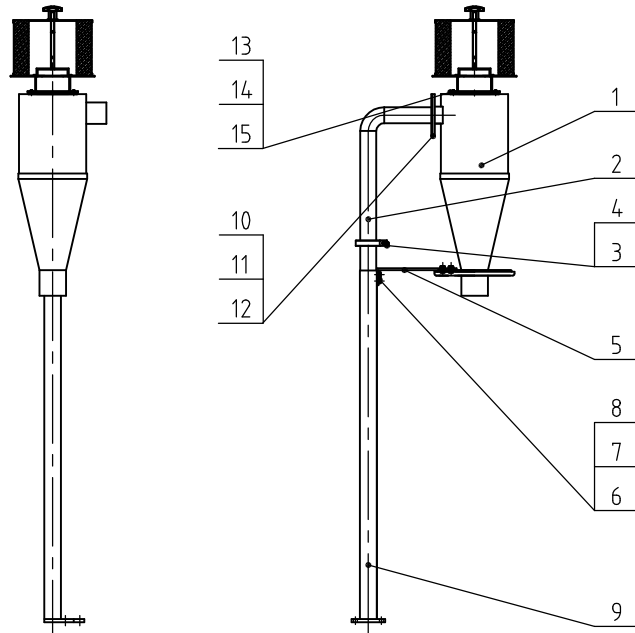

15	YW60512880000	Inner hex. bolt GB/T5783 M5x12-8.8-Longzine		4	
14	S00000000357	Simple filter	Assembly	1	
13	BL59160000121	Filter	Welding assembly	1	
12	YW65008000100	Standard spring washer GB/T93 8-Longzine		4	
11	YW66081900000	Flat washer 8x19x2.0 Longzine		4	
10	YW60081600100	Inner hex. bolt GB/T5781 M6x16-4.8-Longzine		4	
9	--	Lower support	Welding assembly	1	
8	YW65005200000	Standard spring washer GB/T93 5-Longzine	60Mn	2	
7	YW66051000000	Flat washer A grade GB/T97.15-Longzine	14.0HV	6	
6	YW61050600300	Inner hex. column head screw GB/T701M6x6-12.9-Longzine		4	
5	--	Support plate	SPH4	1	
4	YR20001500000	Food connector seal ring 1.5"		1	
3	YW07001500500	1.5" food connector pipe clamp		1	
2	S00000000620	Upper support	Welding assembly	1	
1	S00000000966	Cycloner	Welding assembly	1	
No.	Material number	Name	Mat.	Num.	Remarks

					Draw.		Ver.		Title	SG-16N/20N	Drawing no.			Num.
					Desi.		App.		BC Cyclone Support Rack (option)					Mat.
					Check		by		 信易電熱機械股份有限公司 Shini Plastics Technologies, Inc.					
Mark	Before Mark	After Mod.	Modified by.	Date	App.		Date							

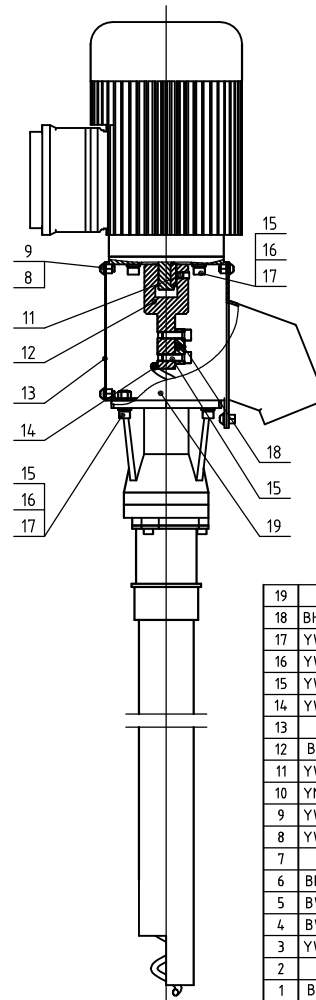
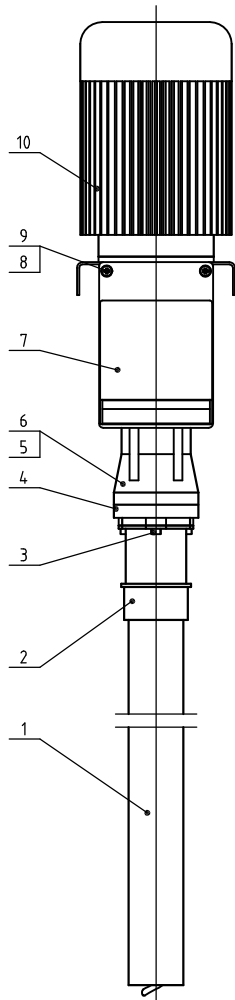

19	--	Transfer box	Welding assembly	1	
18	BH10503600010	Pressing block	SPH10.0	1	
17	YW66061300000	Flat washer 6	14.0HV	10	
16	YW65060000100	Spring washer 6	65Mn	10	
15	YW61062000300	Inner hex. column head screw M6×20	12.9	10	
14	YW01162800600	Conveying spring	SWP-B	1	
13	--	Cover plate	SUS201 1.5	1	
12	BH10162800440	Connecting shaft	Q235A	1	
11	YW68006600000	Inner hex. flat end lock screw M6×6	12.9	2	
10	YM507614.00000	Motor 0.18kW	Assembly	1	
9	YW66051000000	Flat washer 5	14.0HV	8	
8	YW62051000100	Cross recessed pan head screw M5×10	4.8	8	
7	--	Material outlet	SUS201 2.0	1	
6	BP20500300050	Pipe sleeve seal ring	Rubber	1	
5	BW20500000010	Pipe sleeve base	YL112	1	
4	BW20500000110	Pipe sleeve cover	YL112	1	
3	YW60054.000000	Inner hex. screw M5×40	8.8	3	
2	--	Conveying pipe sleeve	Welding assembly	1	
1	BR90162800110	Conveying pipe	PA12	1	
No.	Material number	Name	Mat.	Num.	Remarks

					Draw	Ver.	
					Desi.	App.	
					Check	by	
Mark	Before Mod.	After Mod.	Modified by	Date	App.	Date	

Title		Drawing no.		Scale	Num.
SG-16N/20N					
BC Cyclone Support Rack (option)					
				Surface req.	
				Mat No.	

SHINI 信易電熱機械股份有限公司
Shini Plastics Technologies, Inc.

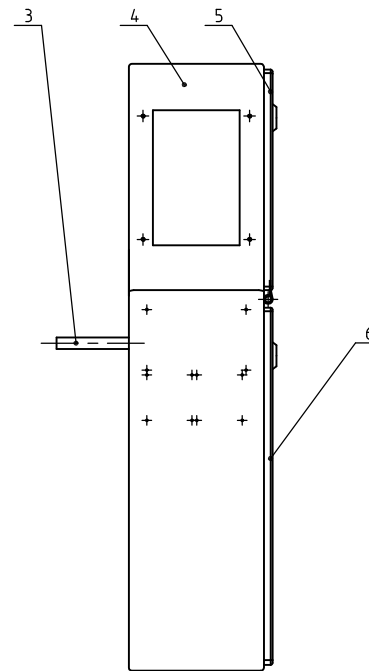
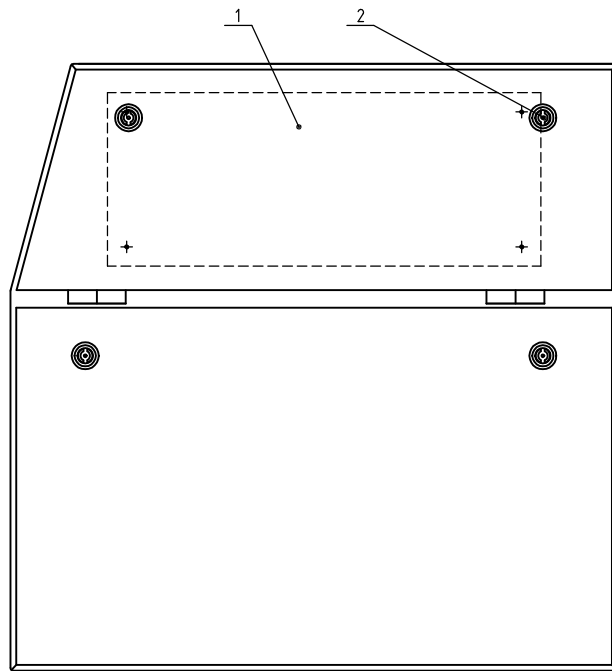

6	--	Shell lower cover plate	SPCC2.0	1	
5	--	Shell upper cover plate	SPCC2.0	1	
4	--	Shell	SPCC3.0	1	
3	--	Feed box support rod	Q235A	1	
2	YW0000000100	Long door lock		4	
1	--	Elec. mount plate	SPCC1.5	1	

No.	Material number	Name	Mat.	Num.	Remarks
-----	-----------------	------	------	------	---------

Mark	Before Mod.	After Mod.	Modified by	Date	Draw.	Ver.	App. by	Date

Title		Drawing no.		Scale	Num.
SG-1621N/1628N/1635N					
Control box assembly					
				Surface req.	
				Mat. No.	

SHINI 普易電熱機械股份有限公司
Shini Plastics Technologies, Inc.

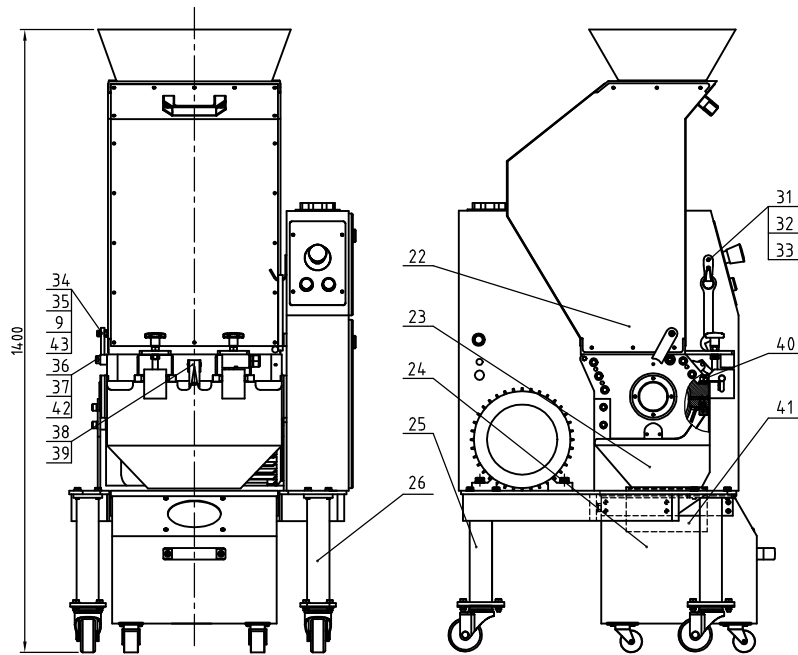

Optional high storage box

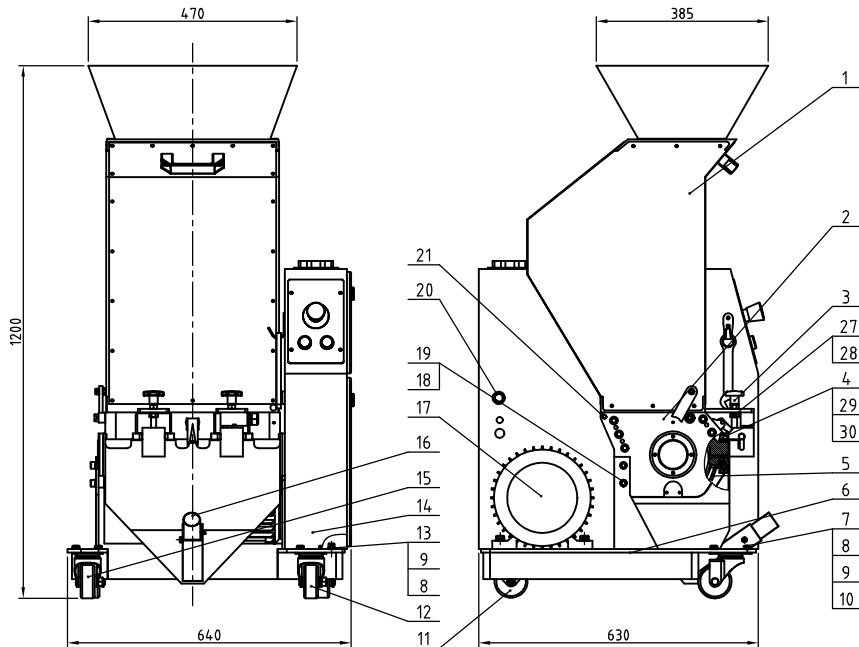

Standard

43	YW64080600000	Hex. nut GB/T6170 M8-Longzine	4	1	29	YW65012000000	Standard spring washer GB/T193 12-Longzine	65Mn	2	14	--	Control box assembly	Assembly	1	
42	YW66102500000	Flat washer 10x25x1.5 Longzine	4	2	28	YW68005500000	Hexagen set of screw with flat nut GB/T1796-Longzine	45H	2	13	YW61081600000	Inner hex. cylindrical head screw GB/T70.1/MK2-12.9-Longzine	12.9	4	
41	BP82163500044	Filter cloth bag	Nylon mesh 400	1	27	BH1124.1000010	Screw lock screw nut	4	2	12	YW03000300000	Brake castor 3"	Assembly	1	
40	YW64012100000	Hex. nut GB/T6170 M12	4	2	26	--	Support foot 2	Q235A&SPH6.0	1	Optional large storage hopper	11	YW03000300300	Black fixed panel castor 3" foot stand bottom plate	Assembly	17
39	YW62041000000	Large cross recessed flat head screw Q235A-Longzine	4.8	2	25	--	Support foot 1	Q235A&SPH6.0	3	Optional large storage hopper	10	YW64080100000	Non-metal insert hex lock nut GB/T889.1 M8	5	2
38	YW02003000400	Snap hook	Assembly	1	24	--	Storage box assembly	Assembly	1	Optional large storage hopper	9	YW66081900000	Flat washer 8x19x2.0 Longzine	14.0HV	21
37	YW61102500000	Inner hex. flat head screw GB/T70.1/MK2-12.9-Longzine	12.9	1	23	--	Storage hopper assembly	Assembly	1	Optional large storage hopper	8	YW65008000100	Standard spring washer GB/T193 8-Longzine	65Mn	4
36	BH10162804110	Limit block sleeve	Q235A	1	22	--	Feed box assembly	Assembly	1	Optional large storage hopper	7	YW60082500100	Inner hex. ball GB/T5783 MK25-12.9-Longzine	4.8	16
35	YW61063000000	Inner hex. column head screw GB/T70.1/MK2-12.9-Longzine	12.9	1	21	YW61062000200	Inner hex. cylindrical head screw GB/T70.1/MK2-12.9-Longzine	12.9	4	6	--	Rack assembly	Assembly	1	
34	--	Limit block	SPH8.0	1	20	YR40162800000	Rubber sleeve	PP	1	5	--	Screen bracket assembly	Assembly	1	
33	JT10001806000	Short click pulley wrench 18	Q235A	1	19	YW65010000000	Standard spring washer GB/T193 10-Longzine	65Mn	7	4	YW60128000000	Hex. bolt GB/T5782 MK2-80-Longzine	8.8	2	
32	YW62041000000	Large cross recessed flat head screw Q235A-Longzine	4.8	2	18	YW61102000000	Inner hex. cylindrical head screw GB/T70.1/MK2-12.9-Longzine	12.9	4	3	BH10204.208510	Feed box star assembly	Assembly	2	
31	YW90351800100	Ball flat Head Hexagon Hex Nut 4.8mm 4.8mm 4.8mm	4.8	1	17	--	Gearing device	Assembly	1	2	--	Lifting chamber assembly	Assembly	1	
30	YW661224.00000	Flat washer GB/T193 12-Longzine	SUS304	2	16	--	Storage hopper assembly	Assembly	1	1	--	Feed box assembly	Assembly	1	
					15	YW03000300200	Mobile castor 3"	Assembly	1	No.	Code	Name	Mat.	Qty.	Remark

制图	版号	标题	SG-1635N	图号	比例	数量
设计	核准	粉碎机总成			1:1	1
校对	审核				表面要求	
标记	更改前	更改后	更改人	日期	物料号	

SHINI 信易電機機械股份有限公司
Shini Plastics Technologies, Inc.

Additional drawing

Standard weight (kg)	Noise during granulating (dB(A))	Max. cutting ability (kg/hr)	Cutting chamber size (mm)	Rotating Blade Qty.	Fixed Blade Qty.	Cutter Blade	Max. shaft rotation (rpm)	Motor power (KW)	(Ver. No.)
210(225)	80~85	60(80)	160×350	15	2	SKD11	235(240)	2.2(3.0)	Ver.F

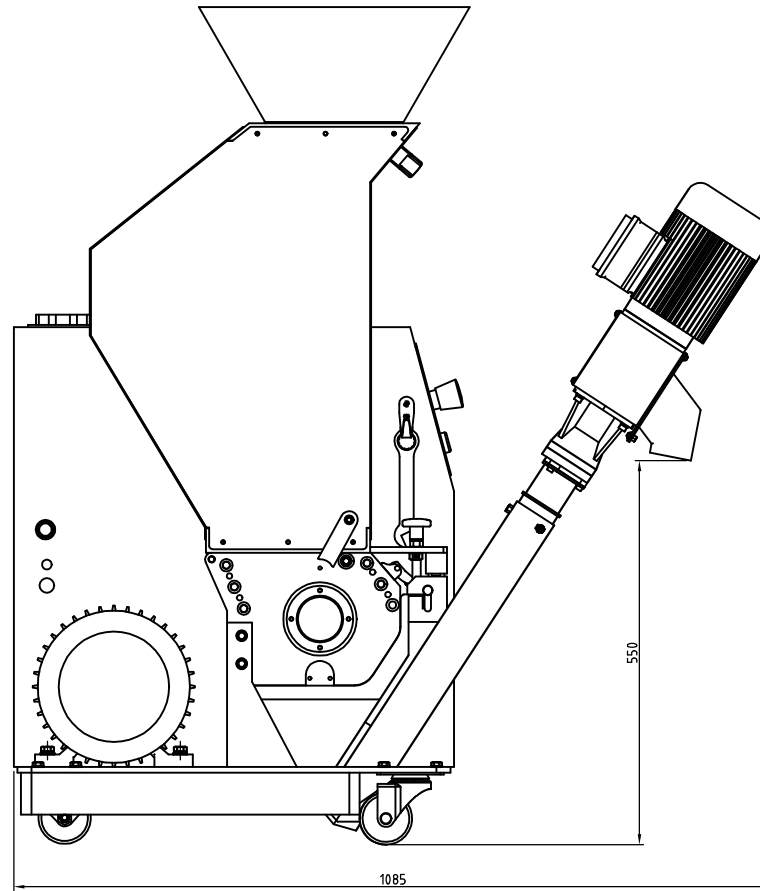

Optional spring conveyor

- Notes: 1) The max. cutting capacity depends on the material size and crushed material;
 2) The noise when granulating is different due to the configuration of crushed materials and motor.
 3) SKD11 Japan JIS standard;
 4) To avoid material sticking the blade, all materials to be crushed shall be crushed at normal temp.;
 5) Machine power: 3Ø, 400VAC, 50Hz;
 6) The values in the brackets are for the optional large motor power model of SG-1635NH.

					制图	版号	标题	图号	比例	数量
					设计	核	SG-1635N			
					校对	准	粉碎机总成			材质
					审核	日期	 信易智能科技有限公司 Shini Plastics Technologies, Inc.		表面要求	
标记	更改前	更改后	更改人	日期				物料号		

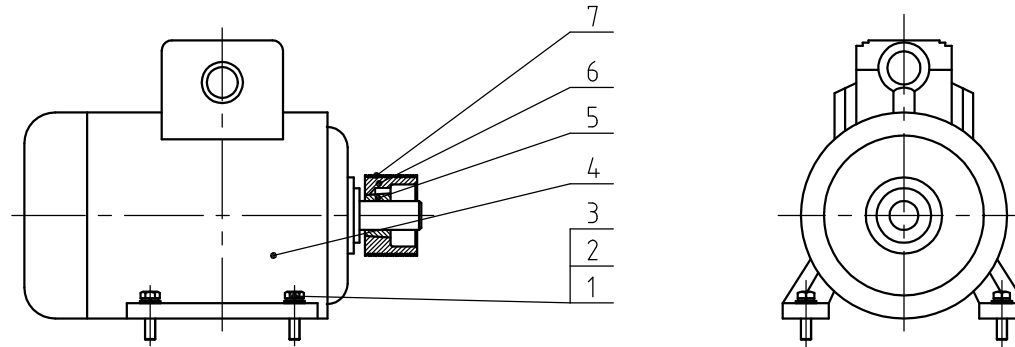

7	YW30205000000	Poly V-belt 20 PJ 50"		1	
6	BW30001605220	Small belt pulley SG-16-P20P78-1210 HT250 (assembly)		1	
5	BW30001605420	Small taper sleeve SG-16-1210-28 HT250 (assembly)		1	
4	YM10202200500	Motor W20 22kW-112M-4P B3R IE3 230V/400V/60V		1	
3	YW66102500000	Flat washer 10x25x15-Longzine	14.0HV	4	
2	YW65010000000	Standard spring washer GB/T93-10-Longzine	65Mn	4	
1	YW60104000100	Hex bolt GB/T5783 M10x40-8.8-Longzine		4	
No.	Material number	Name	Mat.	Num.	Remarks

					Draw.		Ver.		Title	SG-1635N	Drawing no.	Scale		Num.	
					Desi.		App.		Actuating Device				Mat.		
					Check		by		信易電熱機械股份有限公司 Shini Plastics Technologies, Inc.			Surface req.			
Mark	Before Mark	After Mod.	Modified by	Date	App.		Date					Mat No.			

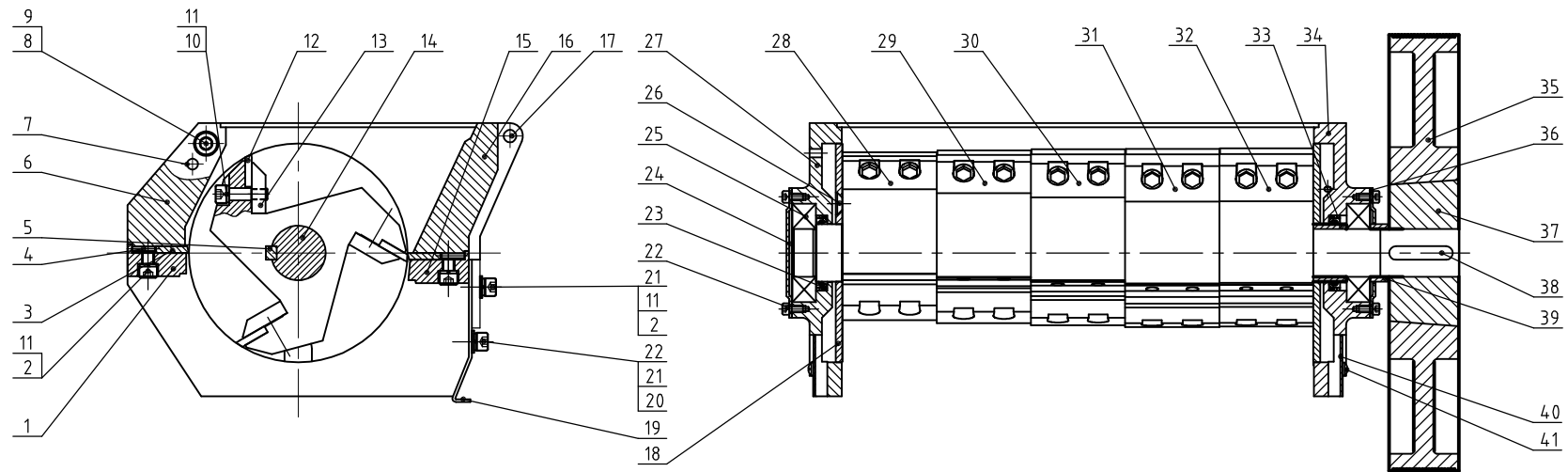

41	YW63050800000	One recessed pan head screw GB/T 818-2014	4.8	4		20	YW61081600000	Inner hex column head screw GB/T 11618-2014		2	
40	--	One plate	SPCC15	2		19	--	Storage box hanging plate	SPCC2.0	1	
39	BH10162823010	Steel	Q235A	1		18	YW45162850000	Fender plate	65Mn	2	
38	BH11161400010	Flat key 10×8×4.6.5	45	1		17	BH10204.100010	Rotating shaft	Q235A	2	
37	BW30001605320	Big taper sleeve SG-16-300-36 H1750 (assembly)	QT500-7	1		16	BH10163560010	Rear box block	QT500-7	1	
36	BL54.162800020	Right bearing outer cover plate	SPCC2.0	1		15	BH10163550010	Rear box block pressing block	Q235A	1	
35	BW30001605120	Large belt wheel SG-16-300-36 H1750 (assembly)	HT250	1		14	BH55163500010	Main shaft	45	1	
34	SG-1628N-B-16	Right end plate	QT500-7	1		13	BH11162700010	Lock blade	Q235A	15	
33	BH10161500010	Sleeve	Q235A	1		12	YW4216284.0000	Rotating blade	SKD11	15	
32	BW30163511810	Blade rest(2)	QT500-7	1		11	YW65008000100	Standard spring washer GB/T 193 8-Longline	65Mn	42	
31	BW30001613110	Blade rest 3	QT500-7	1		10	YW61083000000	Inner hex column head screw GB/T 11618-2014		30	
30	BW30001613010	Blade rest 2	QT500-7	1		9	YW65010000000	Standard spring washer GB/T 193 10-Longline	65Mn	12	
29	BW30001612910	Blade rest 1	QT500-7	1		8	YW61103500000	Inner hex column head screw GB/T 11618-2014		12	
28	BW30162811610	Blade rest(1)	QT500-7	1		7	YW69083500000	Spring column pin GB/T 879.1 8x35	65Mn	8	
27	BW30162807110	Left end plate	QT500-7	1		6	BW30163505110	Front box block	QT500-7	1	
26	YW61082000100	Inner hex column head screw GB/T 11618-2014		6		5	BH10163510010	Flat key 10×337	45	1	
25	YW11620701800	Bearing 6207-2RS1		2	SKF	4	YW68051600000	Inner hex flat end lock screw GB/T 7716-6	33H	8	
24	BL54.162830020	Left bearing outer cover plate	SPCC2.0	1		3	YW41163520000	Rotating blade	SKD11	4	
23	YR80554.2000000	Oil seal φ55×φ4.2×7		2		2	YW61082501200	Inner hex column head screw GB/T 11618-2014		10	
22	YW61051000000	Inner hex column head screw GB/T 11618-2014		8		1	BW30163505210	Front box block pressing block	Q235A	1	
21	YW66081900000	Flat washer A grade GB/T 193 16-16x2.0-Longline	14.0HV	4		No.	Material number	Name	Mat.	Num.	Remarks

					Draw.	Ver.	Title	Drawing no.	Scale	Num.
					Desi.	App. by	SG-1635N		1:1	Mat.
					Check	Date	Cutting Chamber Assembly		Surface req.	
Mark	Before Mod.	After Mod.	Modified by	Date	App.	Date	SHINI 信易電熱機械股份有限公司 Shini Plastics Technologies, Inc.		Mat. No.	

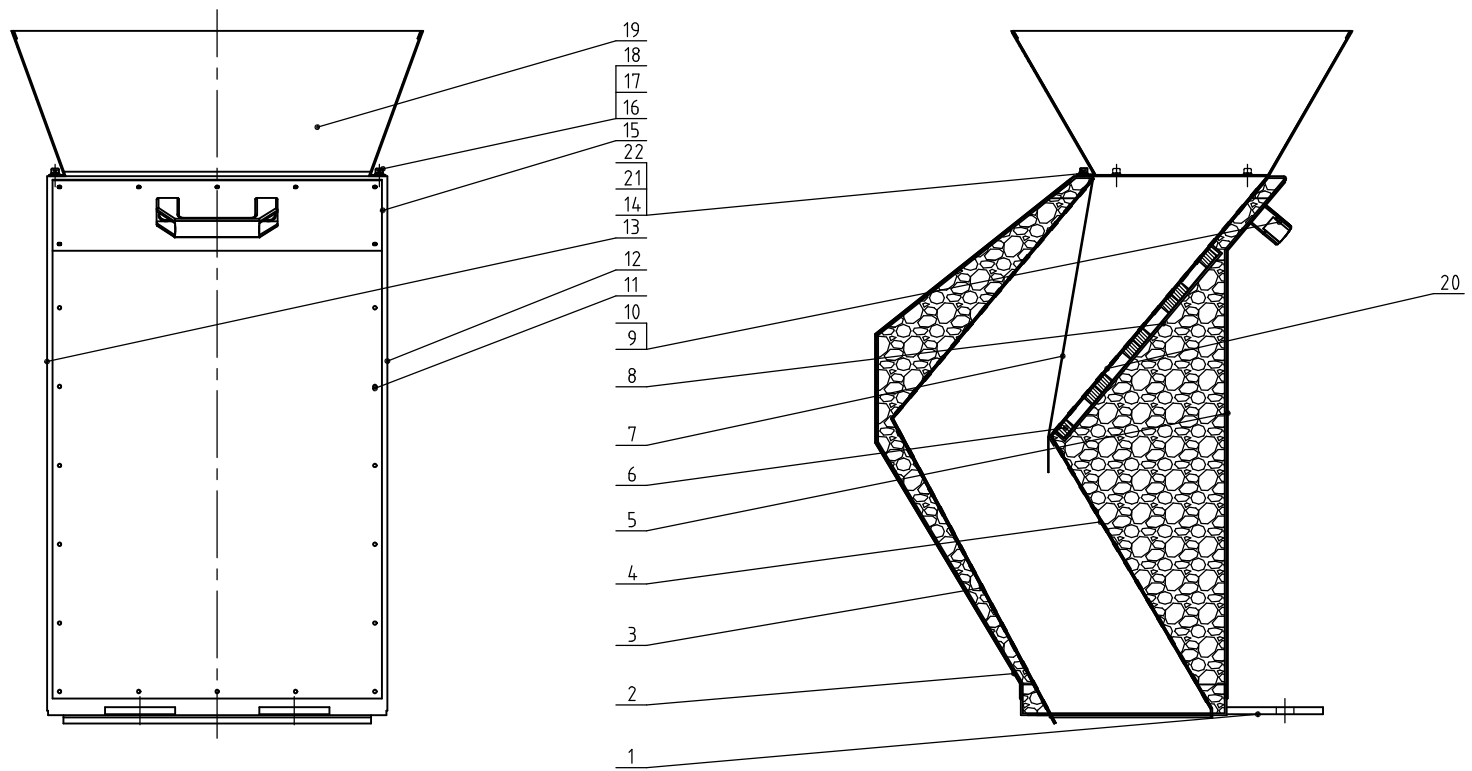

22	YW62051000100	Large recessed flat head screw JIS 1111 M6X10-Longline	12.9	3									
21	--	Fender plate pressing plate	SPCC1.5	1	10	YW61081600000	Inner hex. column head screw M6X6	12.9	2				
20	--	Front inner plate 2	SUS201 2.0	1	9	BW20012000140	Handle L 120	Alum. alloy	1				
19	--	Feed part	SPCC1.5	1	8	--	Magnetic box	SPCC1.2	1				
18	YW66051000000	Flat washer 5	140HV	4	7	--	Fender plate	White water-resistant cloth	1				
17	YW65005200000	Spring washer 5	65Mn	4	6	YW90683200000	Magnet 68x32x12		20				
16	YW61051000000	Inner hex. column head screw M6X6	12.9	4	5	--	Front guard plate	SPCC1.2	1				
15	--	Left & right inner plate	SECC2.0	2	4	--	Front inner plate 1	SECC2.0	1				
14	--	Hopper part	SPCC2.0	1	3	--	Rear inner plate	SECC2.0	1				
13	--	Left guard plate	SPCC1.2	1	2	--	Rear guard plate	SPCC1.2	1				
12	--	Right guard plate	SPCC1.2	1	1	--	Square base	SPCC2.0	1				
11	YW67481900000	Large recessed pan head tapping screw STA.8 xΦ											

Mark	Before Mod.	After Mod.	Modified by	Date	App.	Date	Draw.	Ver.	Title	Drawing no.	Scale	Num.	Remarks
									SG-1635N				
									Feed Box Assembly				
									 信易電熱機械股份有限公司 Shini Plastics Technologies, Inc.		Surface req.		
											Mat. No.		

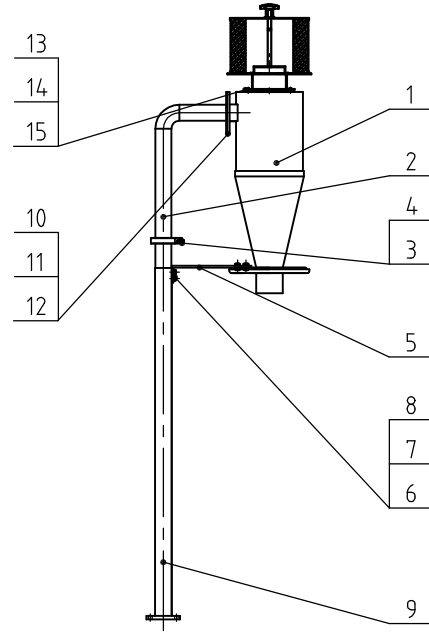
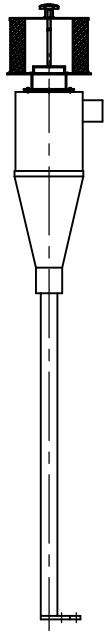

15	YW60512880000	Inner hex. bolt GB/T5783 M5x12-8.8-Longzine		4	
14	S000000000357	Simple filter	Assembly	1	
13	BL59160000121	Filter	Welding assembly	1	
12	YW65008000100	Standard spring washer GB/T93 8-Longzine		4	
11	YW66081900000	Flat washer 8x19x2.0 Longzine		4	
10	YW60081600100	Inner hex. bolt GB/T5781 M6x16-4.8-Longzine		4	
9	--	Lower support	Welding assembly	1	
8	YW65005200000	Standard spring washer GB/T93 5-Longzine	60Mn	2	
7	YW66051000000	Flat washer A grade GB/T97.15-Longzine	14.0HV	6	
6	YW61050600300	Inner hex. column head screw GB/T701 M6x6-12.9-Longzine		4	
5	--	Support plate	SPH4	1	
4	YR20001500000	Food connector seal ring 1.5"		1	
3	YW07001500500	1.5" food connector pipe clamp		1	
2	S000000000620	Upper support	Welding assembly	1	
1	S000000000966	Cycloner	Welding assembly	1	
No.	Material number	Name	Mat.	Num.	Remarks

					Draw.		Ver.		Title	SG-16N/20N	Drawing no.			Num.	
					Desi.		App.		BC Cyclone Support Rack (option)					Mat.	
					Check		by		信易電熱機械股份有限公司 Shini Plastics Technologies, Inc.						
Mark	Before Mark	After Mod.	Modified by	Date	App.		Date								

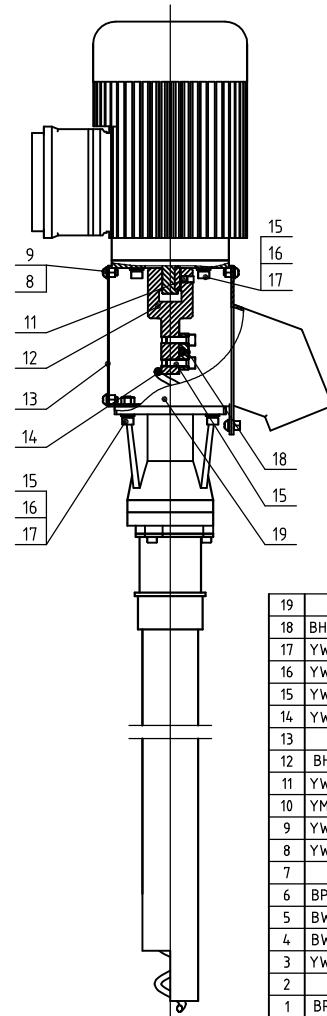
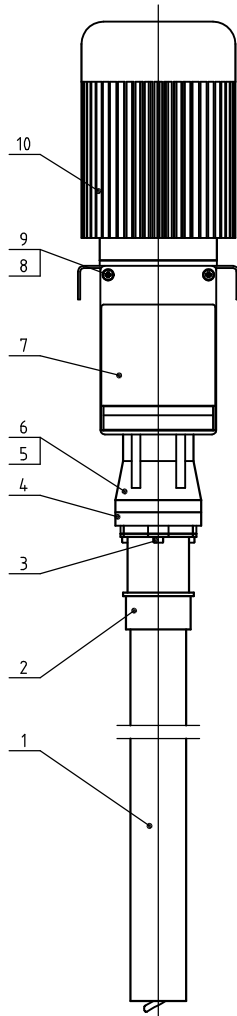

No.	Material number	Name	Mat.	Num.	Remarks
19	--	Transfer box	Welding assembly	1	
18	BH10503600010	Pressing block	SPH10.0	1	
17	YW66061300000	Flat washer 6	14.0HV	10	
16	YW65060000100	Spring washer 6	65Mn	10	
15	YW61062000300	Inner hex. column head screw M6x20	12.9	10	
14	YW01162800600	Conveying spring	SWP-B	1	
13	--	Cover plate	SUS201 1.5	1	
12	BH10162800440	Connecting shaft	Q235A	1	
11	YW68006600000	Inner hex. flat end lock screw M6x6	12.9	2	
10	YM50761400000	Motor 0.18kW	Assembly	1	
9	YW66051000000	Flat washer 5	14.0HV	8	
8	YW62051000100	Cross recessed pan head screw M5x10	4.8	8	
7	--	Material outlet	SUS201 2.0	1	
6	BP20500300050	Pipe sleeve seal ring	Rubber	1	
5	BW20500000010	Pipe sleeve base	YL112	1	
4	BW205000000110	Pipe sleeve cover	YL112	1	
3	YW60054000000	Inner hex. screw M5x40	8.8	3	
2	--	Conveying pipe sleeve	Welding assembly	1	
1	BR90162800110	Conveying pipe	PA12	1	

Draw.	Ver.	Title	Drawing no.	Scale	Num.
Desi.	App. by	SG-16N/20N			
Check	by	Rotary Spring Conveyor (option)			
Mark	Date	 信易電熱機械股份有限公司 Shini Plastics Technologies, Inc.		Surface req.	
Before Mod.	After Mod.			Mat. No.	
Modified by.	Date	App.	Date		

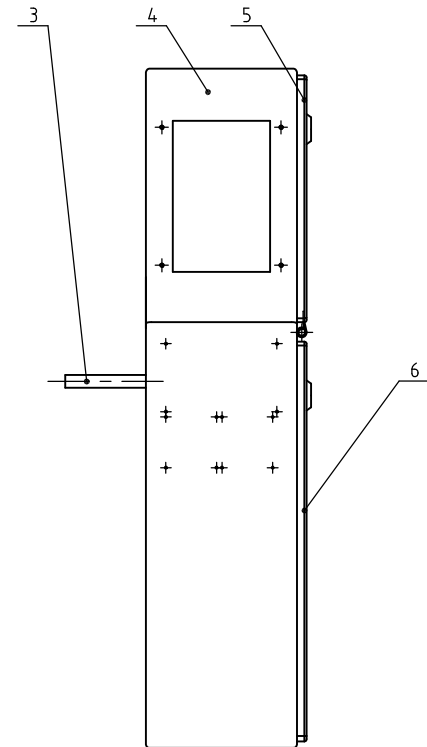
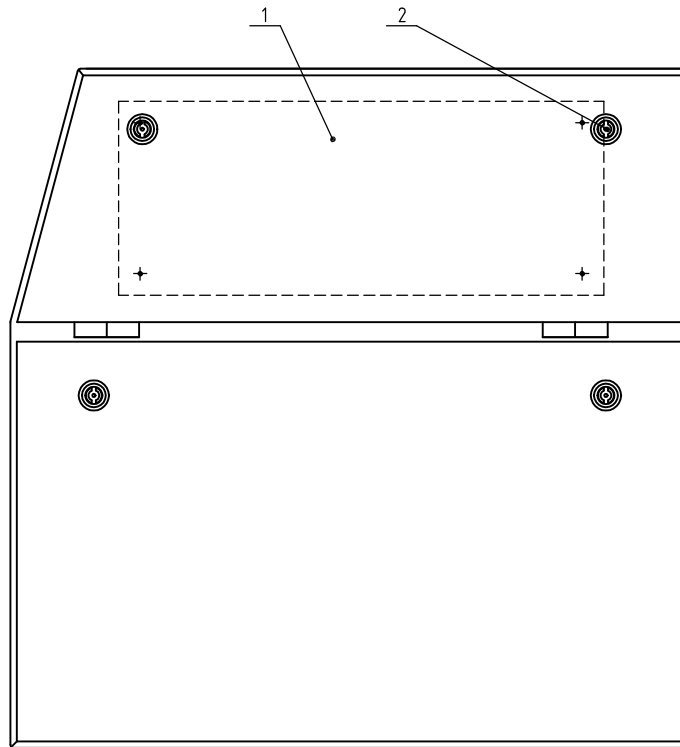

6	--	Shell lower cover plate	SPCC2.0	1	
5	--	Shell upper cover plate	SPCC2.0	1	
4	--	Shell	SPCC3.0	1	
3	--	Feed box support rod	Q235A	1	
2	YW00000000100	Long door lock		4	
1	--	Elec. mount plate	SPCC1.5	1	
No.	Material number	Name	Mat.	Num.	Remarks

					Draw.		Ver.	
					Desi.		App.	
					Check		by	
Mark	Before Mod.	After Mod.	Modified by.	Date	App.		Date	

Title		Drawing no.		Scale	Num.
SG-1621N/1628N/1635N					
Control box assembly					Mat.
				Surface req.	
				Mat No.	



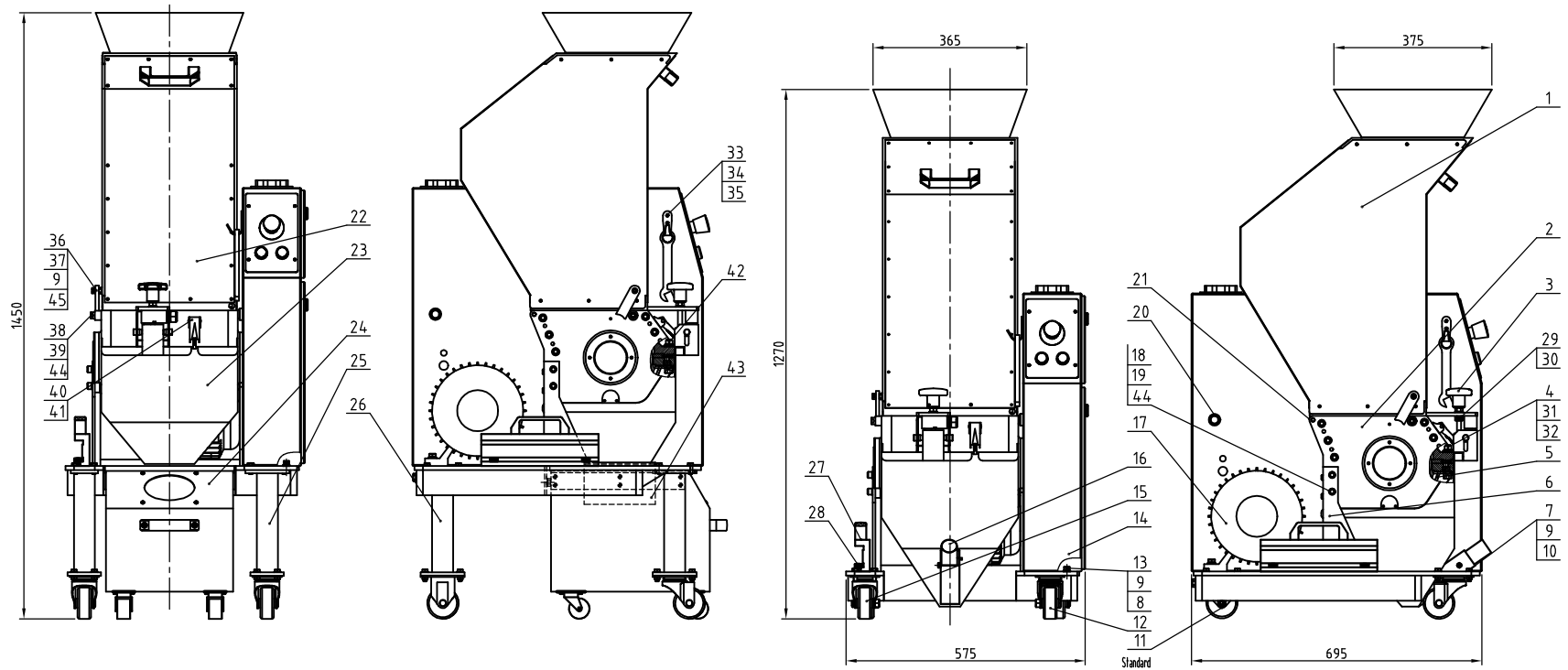

45	YW64.080600000	Hex. nut GB/T6170 M8- Longzine	4	1	31	YW65012000000	Standard spring washer GB/T93 Q-Longzine	65Mn	1	15	YW03000300200	Brake castor 3"	Assembly	1		
44	YW66102500000	Flat washer 16x25x1.5- Longzine	4	2	30	YW68005500000	Hexager socket set screw with flat end GB/T7065-Longzine	4.5H	1	14	--	Control box assembly	Assembly	1		
43	BP82202800044	Filter cloth bag	Nylon mesh 400	1	29	BH1124.1000010	Screw lock screw nut	4	1	13	YW61081600000	Hex hex cylindrical head screw GB/T91.1M20x12.5-Longzine	8.8	4		
42	YW64012100000	Hex. nut GB/T6170 M12- Longzine	4	1	28	YW69621600000	Manual screw M6x20x16	Assembly	2	12	YW03000300000	Brake castor 3"	Assembly	1		
41	YW6204.1000000	Large cross recessed flat head screw 25MM M12x12.5-Longzine	4.8	2	27	BW30202813310	Blade rest shaft	Assembly	1	11	YW03000300300	Fixed castor 3"	Assembly	2		
40	YW02003000400	Snap hook	Assembly	1	26	--	Support foot 1	Q235A&SPH6.0	3	Optional large storage hopper	10	YW64.080600000	Non-metal insert hex. lock nut GB/T6091M8	5	16	
39	YW61102500000	Hex hex. flat head screw GB/T91.1M20x12.5-Longzine	12.9	1	25	--	Support foot 2	Q235A&SPH6.0	1	Optional large storage hopper	9	YW66081900000	Flat washer 8x19x2.0 Longzine	14.0HV	21	
38	BH10162804.110	Limit block sleeve	Q.235A	1	24	--	Storage box assembly	Assembly	1	Optional large storage hopper	8	YW65008000100	Flat washer 8x19x2.0 Longzine	65Mn	4	
37	YW61083000000	Hex hex column head screw GB/T91.1M20x12.5-Longzine	12.9	1	23	--	Storage hopper assembly	Assembly	1	Optional large storage hopper	7	YW60082500300	Hex. bolt GB/T5783 M8x25-12.9-Longzine	4.8	16	
36	--	Limit block	SPH8.0	1	22	--	Feed box assembly	Assembly	1	Optional large storage hopper	6	--	Rack assembly	Assembly	1	
35	JT10001806000	Short click pulley wrench 18	Q.235A	1	21	YW61062000200	Hex hex cylindrical head screw GB/T91.1M20x12.5-Longzine	12.9	4	5	--	--	Screen bracket assembly	Assembly	1	
34	YW6204.1000000	Large cross recessed flat head screw 25MM M12x12.5-Longzine	4.8	2	20	YR4.01628000000	Rubber sleeve	PP	1	4	YW60128000000	Hex. bolt GB/T5782 M10x18-8.8-Longzine	8.8	1		
33	YW90351800100	Ball bearing 1/2 inch ball bearing 3mm hole dia. 18mm outer dia. 5mm width	1	1	19	YW65010000000	Standard spring washer GB/T93 18-Longzine	65Mn	7	3	BH10204.208510	Feed box star assembly	Assembly	1		
32	YW661224.00000	Flat washer GB/T9112- Longzine	1	1	18	YW61102000000	Hex hex cylindrical head screw GB/T91.1M20x12.5-Longzine	12.9	4	2	--	Cutting chamber assembly	Assembly	1		
					17	--	Gearing device	Assembly	1	1	--	Feed box assembly	Assembly	1		
					16	--	Storage hopper assembly	Assembly	1	Standard	No.	Code	Name	Mat.	Qty.	Remark

制图	版号	标题	SG-2028N	图号	比例	数量
设计	核准	粉磨机总成			1:1	1
校对	核				材质	
审核	准				表面要求	
标记	更改前	更改后	更改人	日期	物料号	



Additional drawing

Standard weight (kg)	Noise during granulating (dB(A))	Max. cutting ability (kg/hr)	Cutting chamber size (mm)	Rotating Blade Qty.	Fixed Blade Qty.	Cutter Blade	Max. shaft rotation (rpm)	Motor power (KW)	(Ver. No.)
265(280)	85~90	80	200×280	3	2	SKD11	290	2.2(3.0)	Ver.F

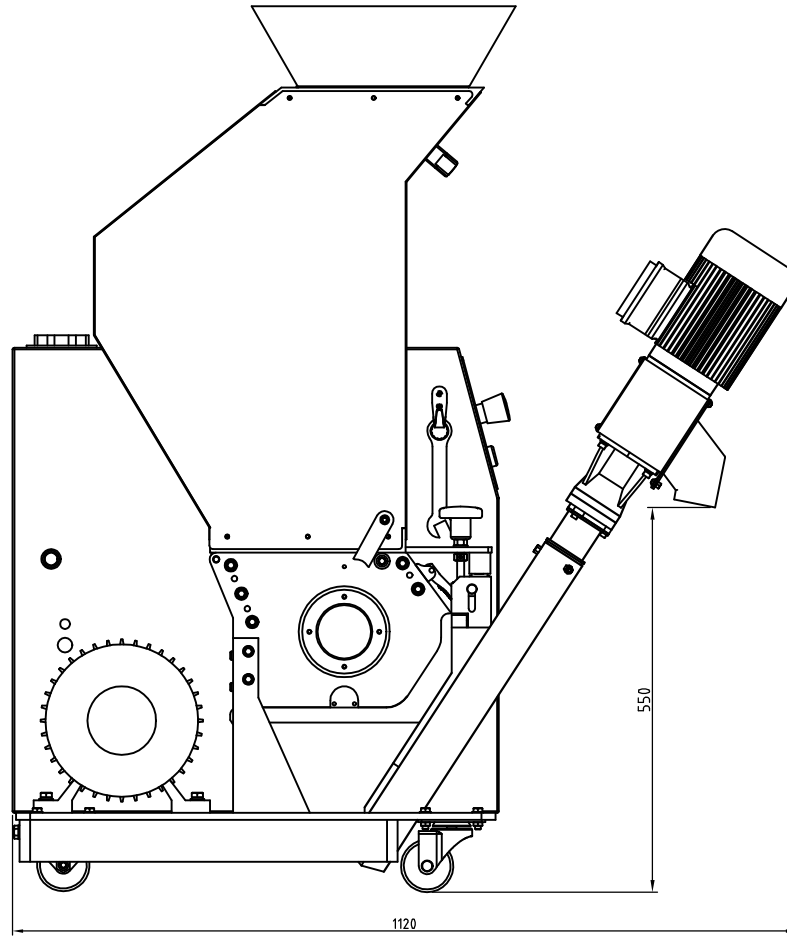

Optional spring conveyor

- Notes: 1) The max. cutting capacity depends on the material size and crushed material;
 2) The noise when granulating is different due to the configuration of crushed materials and motor.
 3) SKD11 Japan JIS standard;
 4) To avoid material sticking the blade, all materials to be crushed shall be crushed at normal temp.;
 5) Machine power: 3Ø, 400VAC, 50Hz;
 6) The values in the brackets are for the optional large motor power model of SG-2028NCH.

					制图	版号	标题	图号	比例	数量
					设计	核	SG-2028N		1:1	1
					校对	准	粉碎机总成		表面要求	材质
标记	更改前	更改后	更改人	日期	审核	日期	SHINI 信易电热机械股份有限公司 Shini Plastics Technologies, Inc.		物料号	

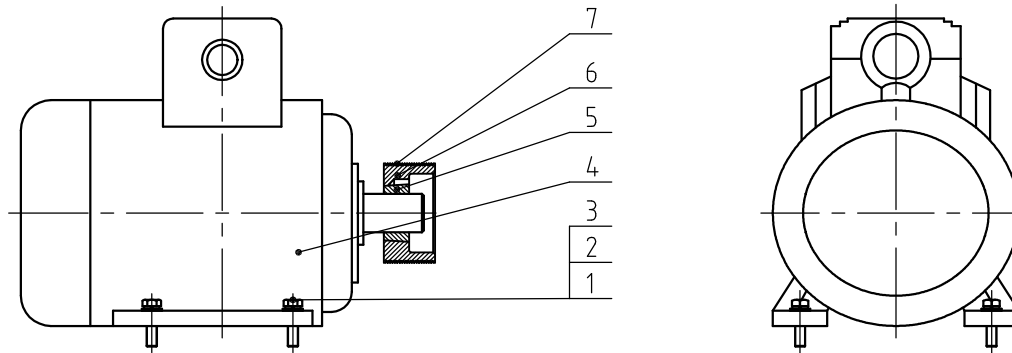

7	YR00532000000	Poly V-belt 20 PJ 50"		1	
6	BW30002005220	Small belt pulley SG-20-PJP 10/3-16/10 HT250 (assembly)		1	
5	BW30002005320	Small taper sleeve SG-20-16/10-28 HT250 (assembly)		1	
4	YM10202200500	Motor W20 2.2kW-102M-6P B3R IE3 230/400V/460V		1	
3	YW66102500000	Flat washer 10x25x15-Longzine	14-0HV	4	
2	YW65010000000	Standard spring washer GB/193 10-Longzine	65Mn	4	
1	YW60104000100	Hex bolt GB/15783 M10x40-8.8-Longzine		4	
No.	Material number	Name	Mat.	Num.	Remarks

					Draw.	Ver.	Title	Drawing no.	Scale	Num.
					Desi.	App.	SG-2028N(C)			
					Check	by	Actuating Device			Mat.
Mark	Before Mark	After Mod.	Modified by	Date	App.	Date	信易電熱機械股份有限公司 Shini Plastics Technologies, Inc.		Surface req.	
									Mat No.	

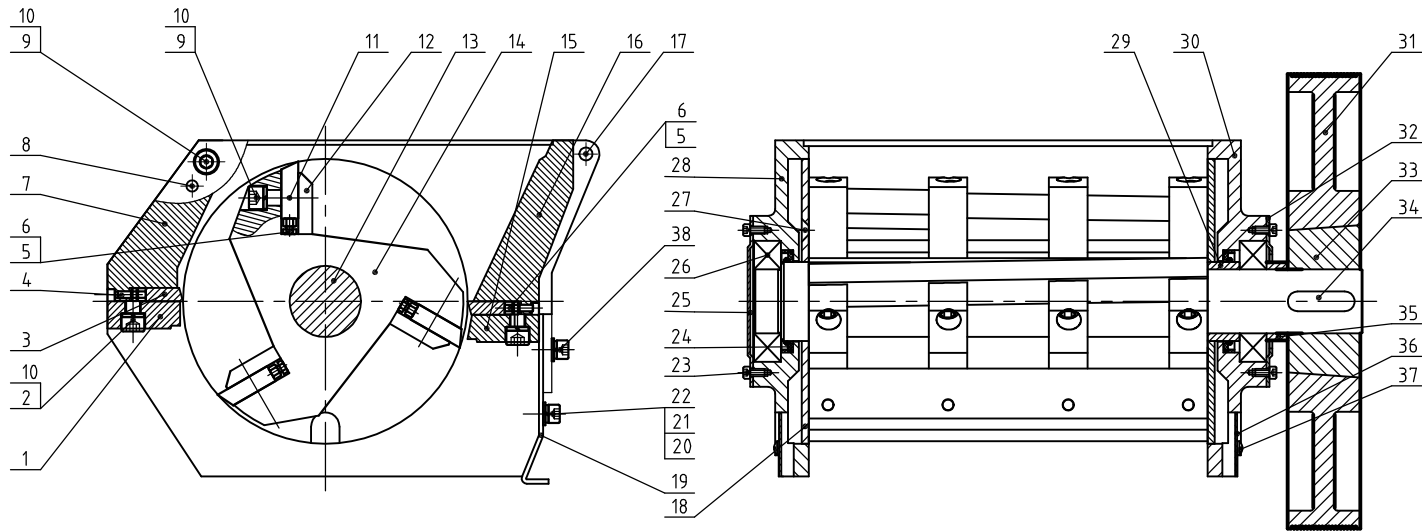

27	YW61082000100	Inner hex. countersink head screw GB/T11963-12.9-Longzine		6		12	BH110202850010	Blade pressing plate	Q235A	3	
26	YW11620901800	Bearing 6209-2RS1		2	SKF	11	YW43202800000	Rotating blade	SKD11	3	
25	BL50204201320	Left bearing ext. cover plate	SPCC2.0	1		10	YW65010000000	Standard spring washer GB/T93 11-Longzine	65Mn	30	
24	YR80557200000	Oil seal $\phi 77 \times \phi 55 \times 8$		2		9	YW61103500000	Inner hex. column head screw GB/T11963-12.9-Longzine		24	
23	YW61051000000	Inner hex. column head screw GB/T11963-12.9-Longzine		8		8	YW69083500000	Spring column pin GB/T 879.1 8x35	65Mn	8	
38	YW61082501200	Inner hex. column head screw GB/T11963-12.9-Longzine		2		7	BW30202813410	Front box block	QT500-7	1	
37	YW63050800000	Cross recessed pan head screw GB/T49 15x4-Longzine		4		6	YW64050800100	Hex. nut GB/T6170 M5-A2-70(SUS)		10	
36	--	Clamp plate	SPCC1.5	2		5	YW60512880000	Hex. bolt GB/T5783 M5x12-8.8-Longzine		10	
35	BH10204203010	Shim 1	Q235A	1		4	YW68051600000	Inner hex. flial end lock screw GB/T11963-12.9-Longzine		4	
34	BH11020400010	Flat key 14x9x4.6.5	Q235A	1		3	YW41202800600	Fixed blade	SKD11	2	
33	BW30002005520	Big taper sleeve SG-201-302-45 H1250(assembly)		1		17	BH10204100010	Rotating shaft	Q235A	2	
32	BL50204201820	Right bearing ext. cover plate	SPCC2.0	1		16	BW30202813610	Rear box block	QT500-7	1	
31	BW30001605120	Large ball wheel SG-401-301-300020(assembly)		1		15	BW30202813710	Rear box block pressing block	Q235A	1	
30	BW30204207110	Right end plate	QT500-7	1		14	--	Blade rest	45	4	
29	BH10204500010	Shim 2	Q235A	1		13	BH11002028010	Blade rest shaft	45	1	
28	BW30204207010	Left end plate	QT500-7	1		No.	Material number	Name	Mat.	Num.	Remarks

Draw.	Ver.	Title	Drawing no.	Scale	Num.
Desi.	App. by	SG-2028N	Cutting Chamber Assembly		Mat.
Check	App. by	信易電熱機械股份有限公司 Shini Plastics Technologies, Inc.		Surface req.	
Mark	Date			Mat. No.	
Before Mod.	After Mod.	Modified by	Date	App.	Date

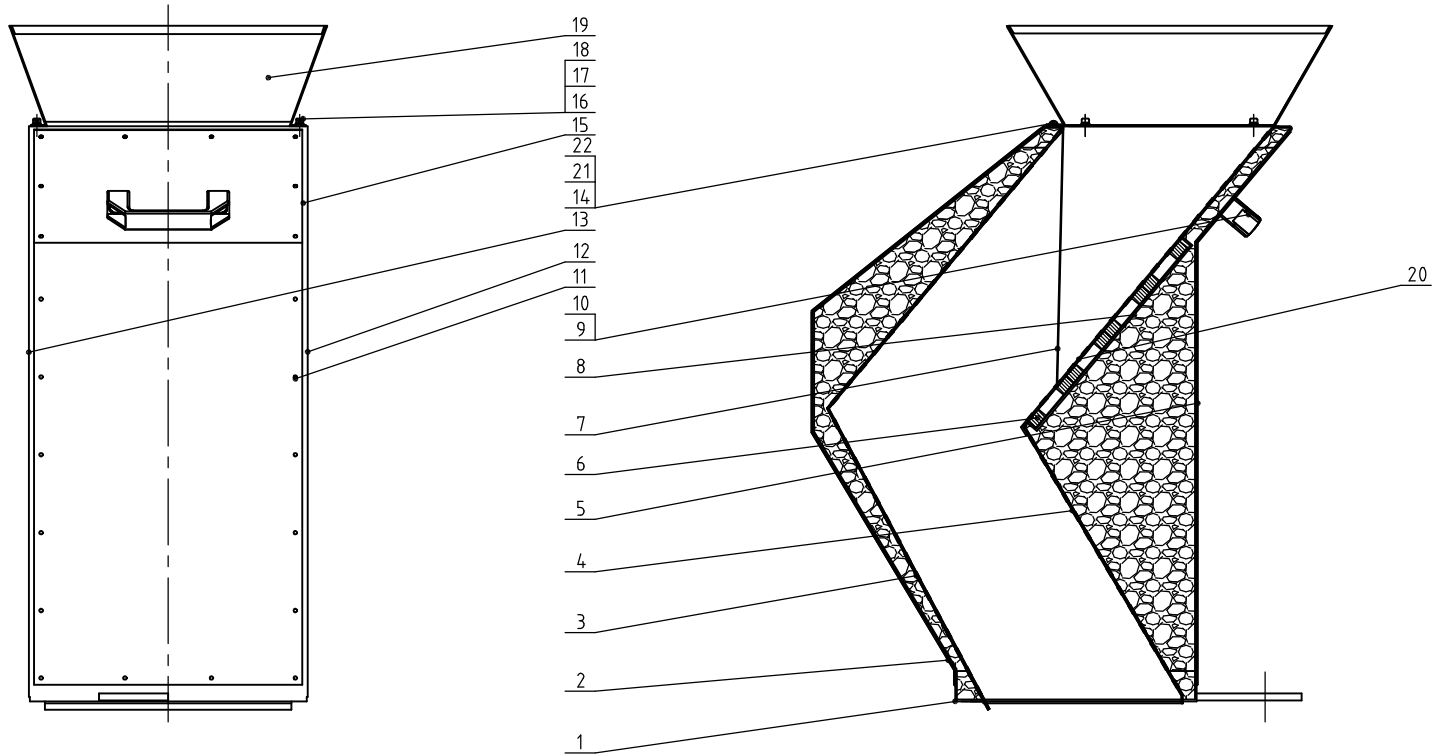

22	YW2051000100	Large recessed flat head screw J5 1111MS-10-Longline	12.9	3									
21	--	Fender plate pressing plate	SPCC1.5	1		10	YW61081600000	Inner hex. column head screw M16	8.8		2		
20	--	Front inner plate 2	SUS201 2.0	1		9	BW20012000140	Handle L	Alum. alloy		1		
19	--	Feed part	SPCC1.5	1		8	--	Magnetic box	SUS201 1.2		1		
18	YW66051000000	Flat washer 5	140HV	4		7	--	Fender plate	Fender pressing plate		1		
17	YW65005200000	Spring washer 5	65Mn	4		6	YW90683200000	Magnet 68×32×12			16		
16	YW61051000000	Inner hex. column head screw M6x10	12.9	4		5	--	Front guard plate	SPCC1.2		1		
15	--	Left & right inner plate	SECC2.0	2		4	--	Front inner plate 1	SECC2.0		1		
14	--	Hopper part	SPCC2.0	1		3	--	Rear inner plate	SECC2.0		1		
13	--	Left guard plate	SPCC1.2	1		2	--	Rear guard plate	SPCC1.2		1		
12	--	Right guard plate	SPCC1.2	1		1	--	Square base	SPCC3.0		1		
11	YW67481900000	Large recessed pan head tapping screw S14.6x19		4.4		No.	Material number	Name	Mat.	Num.	Remarks		

Mark	Before Mod.	After Mod.	Modified by	Date	App.	Date	Draw.	Ver.	Title	SG-2028N(C)	Drawing no.	Scale	Num.	Remarks
							Desi.		Feed Box Assembly					
							Check	App.	 信易電熱機械股份有限公司 Shini Plastics Technology, Inc.		Surface req.			
											Mat. No.			

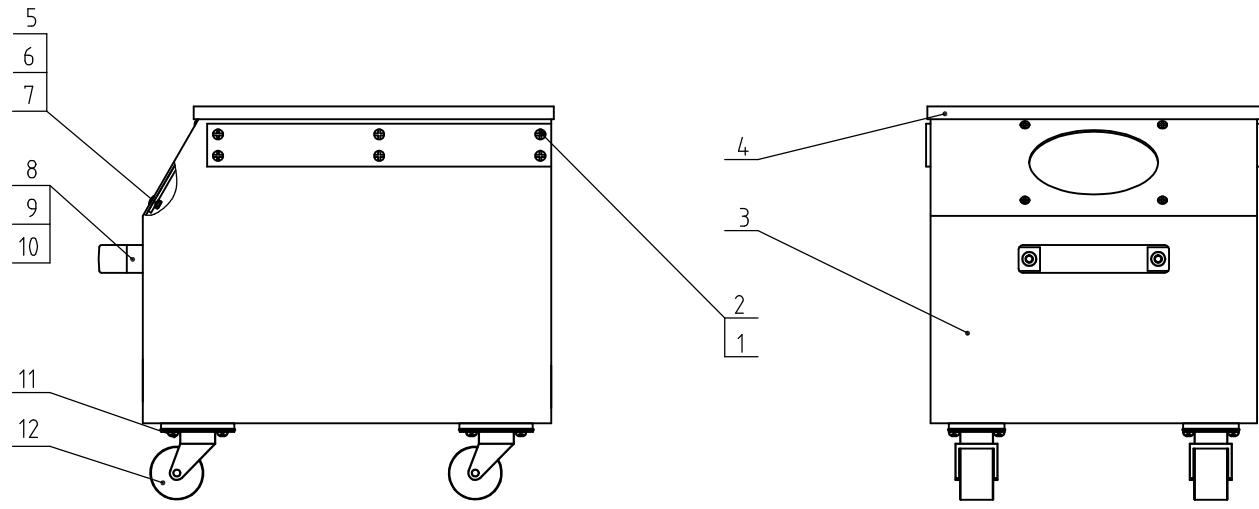

12	YW03000200000	Black castor 2'	Assembly	4	
11	YW62050500000	Large cross recessed flat head screw JS1111 M5×5	Longzine	16	
10	YW64000800100	Anti-loose nut M8	6	2	
9	YW61081600000	Inner hex. nut M8×16	8.8	2	
8	BW20012000140	Handle	Alum. alloy	1	
7	YW64040700100	Anti-loose nut M4	5	4	
6	YW62041000000	Large cross flat head screw JS1111 M4×10-Longzine	8.8	4	
5	--	Visual window transparent plate	Acrylic	1	
4	--	Storage box cover	SECC2.0	1	
3	--	Storage case	SECC2.0	1	
2	YW61040600000	Inner hex countersunk screw GB/T170.3 M4×6-12.9-Longzine	8.8	12	
1	BR90202800310	Fender plate	Teflon	2	
No.	Material number	Name	Mat.	Num.	Remarks

					Draw.		Ver.		Title	SG-2028N(C)	Drawing no.		Num.	
					Desi.		App.		Storage Box Assembly (option)				Mat.	
					Check		by		 信易電熱機械股份有限公司 Shini Plastics Technologies, Inc.					
Mark	Before Mark	After Mod.	Modified by	Date	App.		Date							

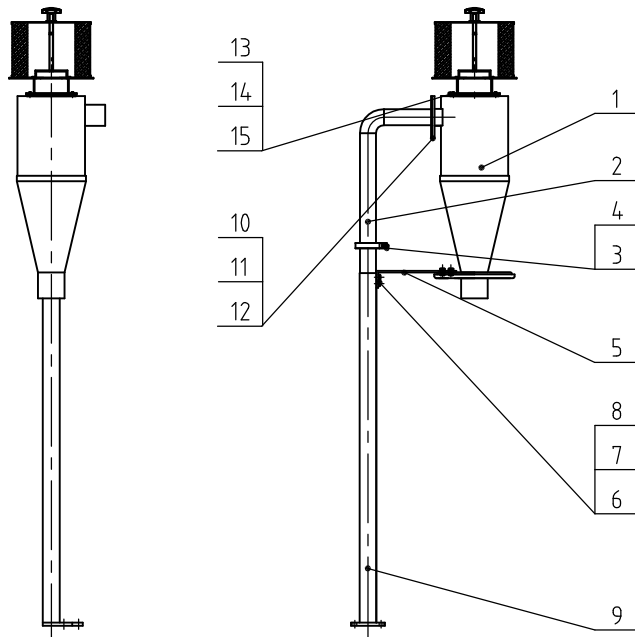

15	YW60512880000	Inner hex. bolt GB/T5783 M5x12-8.8-Longzine		4	
14	S00000000357	Simple filter	Assembly	1	
13	BL59160000121	Filter	Welding assembly	1	
12	YW65008000100	Standard spring washer GB/T93 8-Longzine		4	
11	YW66081900000	Flat washer 8x19x2.0 Longzine		4	
10	YW60081600100	Inner hex. bolt GB/T5781 M8x16-4.8-Longzine		4	
9	--	Lower support	Welding assembly	1	
8	YW65005200000	Standard spring washer GB/T93 5-Longzine	60Mn	2	
7	YW66051000000	Flat washer A grade GB/T97.15-Longzine	14.0HV	6	
6	YW61050600300	Inner hex. column head screw GB/T701 M5x6-12.9-Longzine		4	
5	--	Support plate	SPH4	1	
4	YR20001500000	Food connector seal ring 1.5"		1	
3	YW07001500500	1.5" food connector pipe clamp		1	
2	S00000000620	Upper support	Welding assembly	1	
1	S00000000966	Cycloner	Welding assembly	1	
No.	Material number	Name	Mat.	Num.	Remarks

					Draw	Ver.	Title	Drawing no.		Num
					Desi	App.	SG-16N/20N			Mat.
					Check	by	BC Cyclone Support Rack (option)			
Mark	Before Mark	After Mod.	Modified by	Date	App.	Date	信易電熱機械股份有限公司 Shini Plastics Technologies, Inc.			

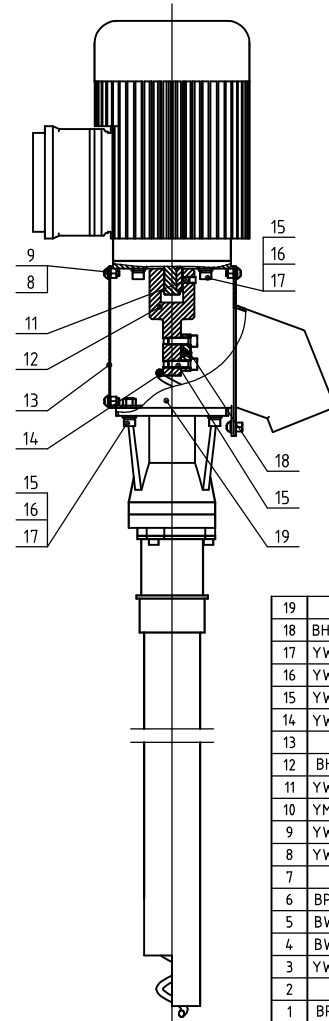
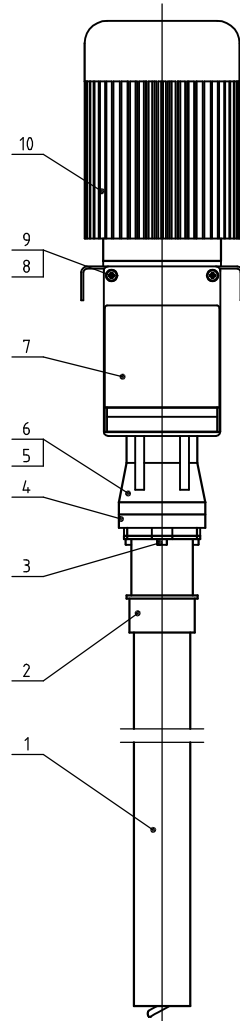

19	--	Transfer box	Welding assembly	1	
18	BH10503600010	Pressing block	SPH10.0	1	
17	YW66061300000	Flat washer 6	14.0HV	10	
16	YW65060000100	Spring washer 6	65Mn	10	
15	YW61062000300	Inner hex. column head screw M6×20	12.9	10	
14	YW01162800600	Conveying spring	SWP-B	1	
13	--	Cover plate	SUS201 1.5	1	
12	BH10162800440	Connecting shaft	Q235A	1	
11	YW68006600000	Inner hex. flat end lock screw M6×6	12.9	2	
10	YM507614.00000	Motor 0.18kW	Assembly	1	
9	YW66051000000	Flat washer 5	14.0HV	8	
8	YW62051000100	Unss recessed pan head screw M5×10	4.8	8	
7	--	Material outlet	SUS201 2.0	1	
6	BP20500300050	Pipe sleeve seal ring	Rubber	1	
5	BW20500000010	Pipe sleeve base	YL112	1	
4	BW20500000110	Pipe sleeve cover	YL112	1	
3	YW60054.0000000	Inner hex. screw M5×40	8.8	3	
2	--	Conveying pipe sleeve	Welding assembly	1	
1	BR90162800110	Conveying pipe	PA12	1	
No.	Material number	Name	Mat.	Num.	Remarks

Draw.	Ver.	Title	SG-16N/20N	Drawing no.	Scale	Num.
Desi.	App.	Rotary Spring Conveyor (option)		信易電熱機械股份有限公司 Shini Plastics Technologies, Inc.	Surface req.	Mat.
Check	by					
Mark	Before Mod.	After Mod.	Modified by.	Date	App.	Date

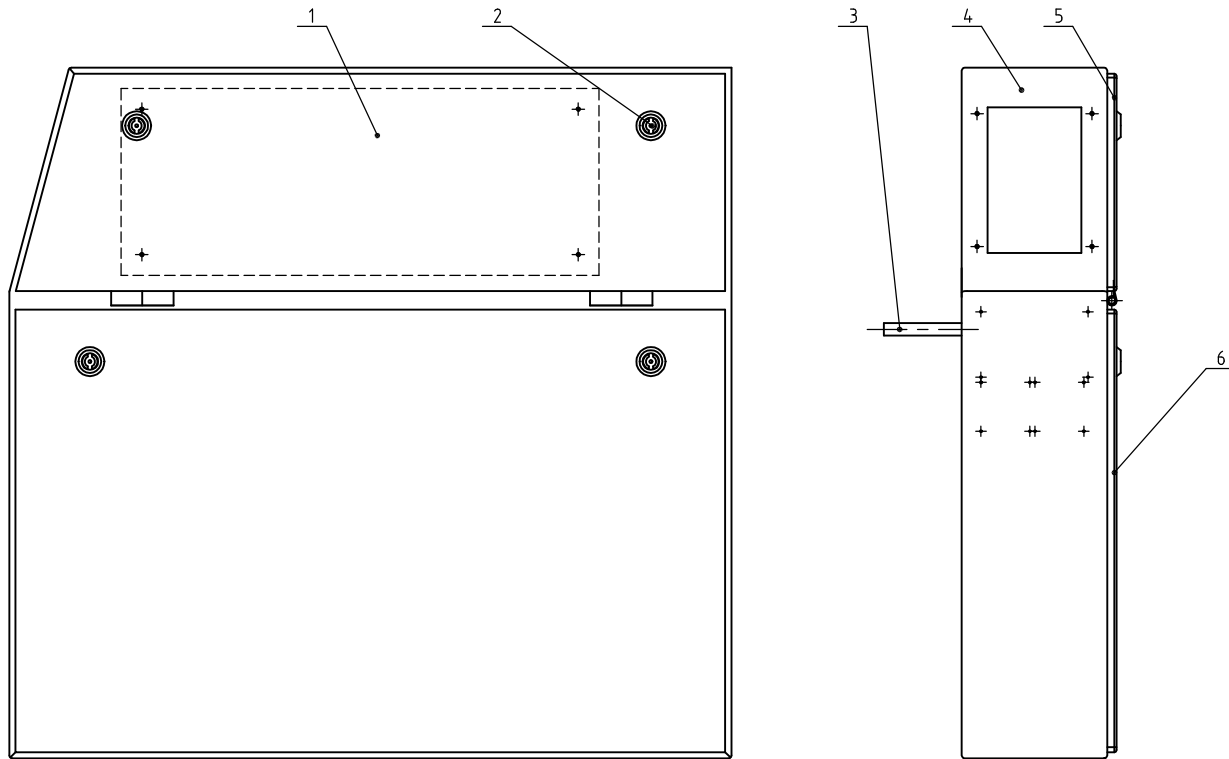

6	--	Shell lower cover plate	SPCC2.0	1	
5	--	Shell upper cover plate	SPCC2.0	1	
4	--	Shell	SPCC3.0	1	
3	--	Feed box support rod	Q235A	1	
2	YW00000000100	Long door lock		4	
1	--	Elec. mount plate	SPCC1.5	1	
No.	Material number	Name	Mat.	Num.	Remarks

					Draw.		Ver.	
					Desi.		App.	
					Check		by	
Mark	Before Mod.	After Mod.	Modified by	Date	App.		Date	

Title		Drawing no.		Scale	Num.
SG-2028N(C)/2042N(C)					
Control box assembly				☐	Mat.
				Surface req.	
				Mat No.	

SHINI 信易電熱機械股份有限公司
Shini Plastics Technologies, Inc.

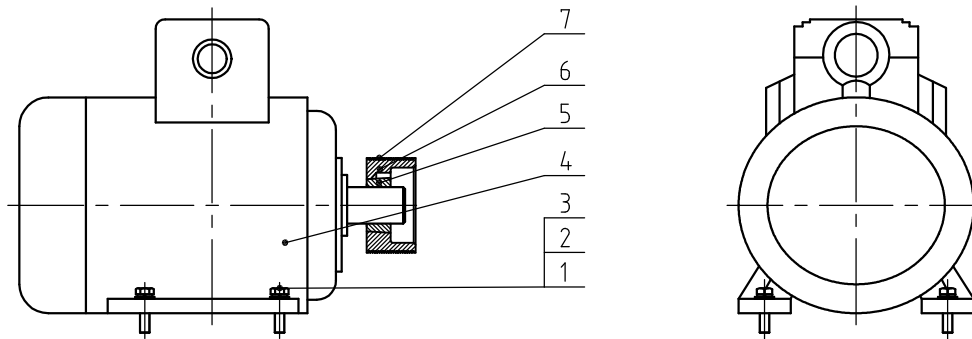

7	YR00532000000	Poly V-belt 20 PJ 50"		1	
6	BW30002005220	Small belt pulley SG-70-PWP/PW/3-N/N/H/250 (assembly)		1	
5	BW30002005320	Small taper sleeve SG-20-1610-20/H/250 (assembly)		1	
4	YM10202200500	Motor W20 220W-102M-4P B3R/E3 23W/40W/46W		1	
3	YW66102500000	Flat washer 10x25x1.5-Longzine	14-0HV	4	
2	YW65010000000	Standard spring washer GB/T193 10-Longzine	65Mn	4	
1	YW60104000100	Hex bolt GB/T5783 M10x4.0-8.8-Longzine		4	
No.	Material number	Name	Mat.	Num.	Remarks

					Draw.		Ver.		Title	SG-2028N(C)	Drawing no.	Scale		Num.	
					Desi.		App.		Actuating Device				Mat.		
					Check		by		信易電熱機械股份有限公司 Shini Plastics Technologies, Inc.		Surface req.				
Mark	Before Mark	After Mod.	Modified by	Date	App.	Date		Mat No.							

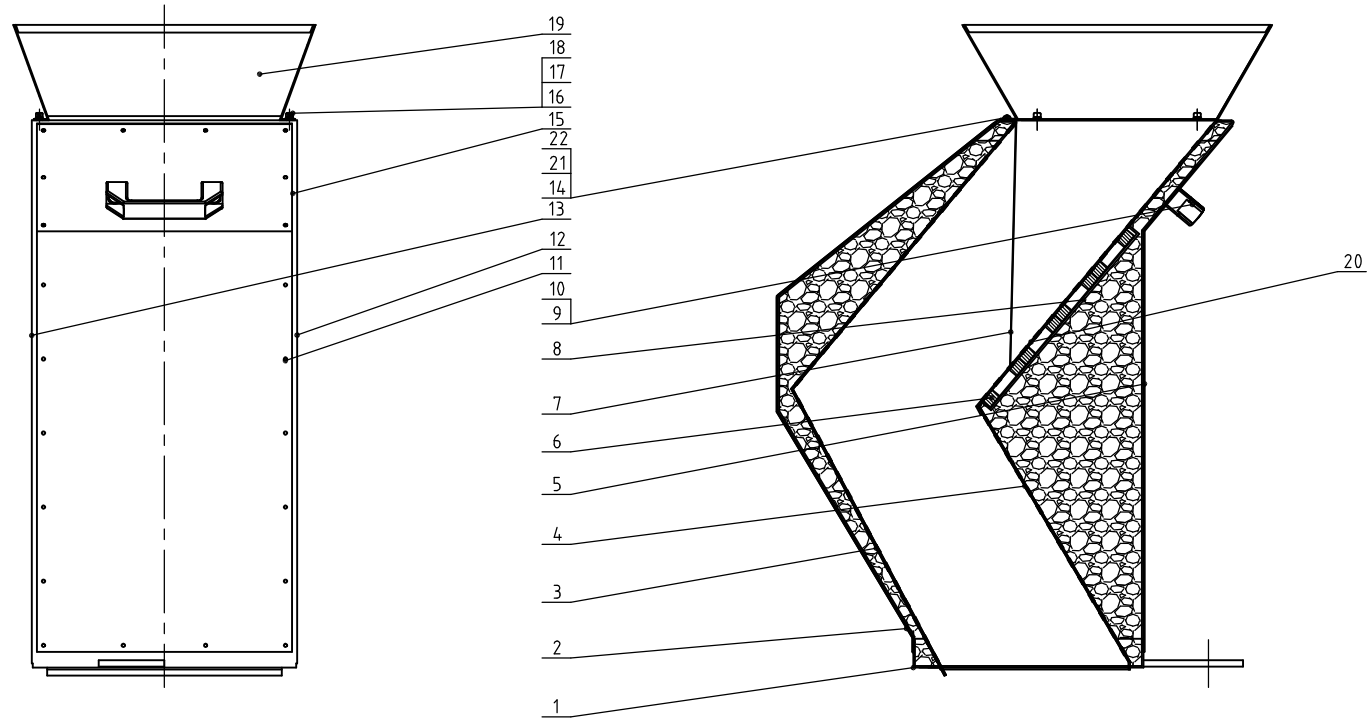

22	YW2051000100	Large recessed flat head screw JS 1111 M5-D-Longline	12.9	3									
21	--	Fender plate pressing plate	SPCC1.5	1		10	YW61081600000	Inner hex column head screw M6x6	8.8	2			
20	--	Front inner plate 2	SUS201 2.0	1		9	BW20012000140	Handle L 120	Alum. alloy	1			
19	--	Feed part	SPCC1.5	1		8	--	Magnetic box	SUS201 1.2	1			
18	YW66051000000	Flat washer 5	140HV	4		7	--	Fender plate	Fender pressing plate	1			
17	YW65005200000	Spring washer 5	65Mn	4		6	YW90683200000	Magnet 68x32x12		16			
16	YW61051000000	Inner hex column head screw M5x10	12.9	4		5	--	Front guard plate	SPCC1.2	1			
15	--	Left & right inner plate	SECC2.0	2		4	--	Front inner plate 1	SECC2.0	1			
14	--	Hopper part	SPCC2.0	1		3	--	Rear inner plate	SECC2.0	1			
13	--	Left guard plate	SPCC1.2	1		2	--	Rear guard plate	SPCC1.2	1			
12	--	Right guard plate	SPCC1.2	1		1	--	Square base	SPCC3.0	1			
11	YW67481900000	Large recessed pan head tapping screw ST4.4-D		4.4		No.		Material number	Name	Mat.	Num.	Remarks	

Draw.	Ver.	Title	SG-2028N(C)	Drawing no.	Scale	Num.
Desi.	App. by	Feed Box Assembly				Mat.
Check	Date	SHINI 慎易電熱機械股份有限公司		Surface req.		
Mark	Before Mod.	After Mod.	Modified by	Date	App.	Date
				Shini Plastics Technology, Inc.		Mat No.

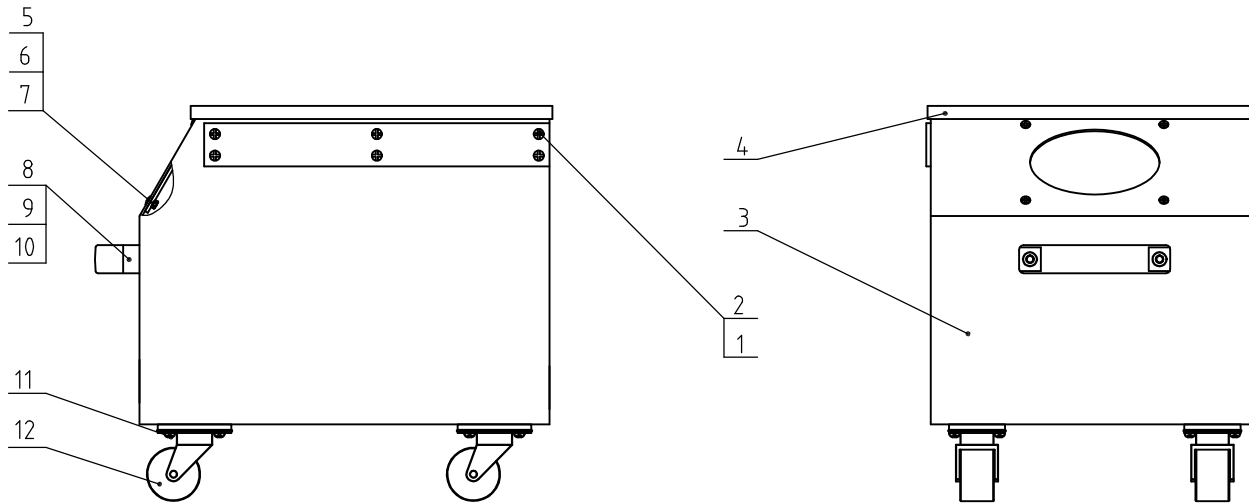

12	YW03000200000	Black castor 2"	Assembly	4	
11	YW62050500000	Large cross recessed flat head screw JS1111 M5x5	Longzine	16	
10	YW64000800100	Anti-loose nut M8	6	2	
9	YW61081600000	Inner hex. nut M8x16	8.8	2	
8	BW20012000140	Handle	Alum. alloy	1	
7	YW64040700100	Anti-loose nut M4	5	4	
6	YW62041000000	Large cross flat head screw JS1111 M4x10-Longzine	8.8	4	
5	--	Visual window transparent plate	Acrylic	1	
4	--	Storage box cover	SECC2.0	1	
3	--	Storage case	SECC2.0	1	
2	YW61040600000	Inner hex. countersunk screw GB/770.3 M4x6-12.9-Longzine	8.8	12	
1	BR90202800310	Fender plate	Teflon	2	
No.	Material number	Name	Mat.	Num.	Remarks

					Draw.		Ver.		Title	SG-2028N(C)	Drawing no.			Num.	
					Desi.		App.		Storage Box Assembly (option)					Mat.	
					Check		by		 信易電熱機械股份有限公司 Shini Plastics Technologies, Inc.						
Mark	Before Mark	After Mod.	Modified by	Date	App.		Date								

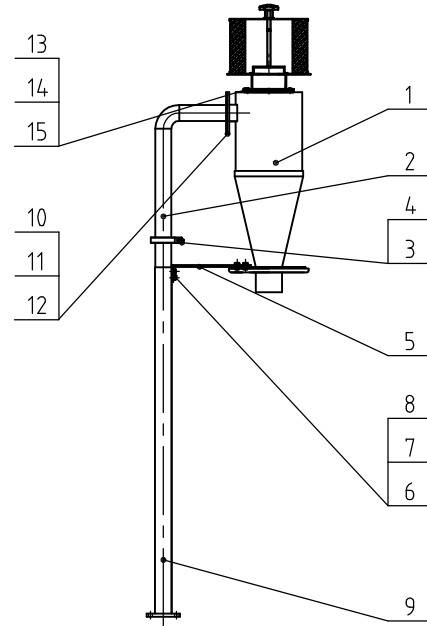
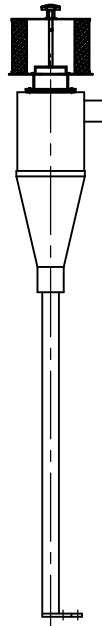

15	YW60512880000	Inner hex. bolt GB/T5783 M5x12-8.8-Longzine		4	
14	S000000000357	Simple filter	Assembly	1	
13	BL59160000121	Filter	Welding assembly	1	
12	YW65008000100	Standard spring washer GB/T93 8-Longzine		4	
11	YW66081900000	Flat washer 8x19x2.0 Longzine		4	
10	YW60081600100	Inner hex. bolt GB/T5781 M6x16-4.8-Longzine		4	
9	--	Lower support	Welding assembly	1	
8	YW65005200000	Standard spring washer GB/T93 5-Longzine	60Mn	2	
7	YW66051000000	Flat washer A grade GB/T97.15-Longzine	14.0HV	6	
6	YW61050600300	Inner hex. column head screw GB/T701M6x6-12.9-Longzine		4	
5	--	Support plate	SPH4	1	
4	YR20001500000	Food connector seal ring 1.5"		1	
3	YW07001500500	1.5" food connector pipe clamp		1	
2	S000000000620	Upper support	Welding assembly	1	
1	S000000000966	Cycloner	Welding assembly	1	
No.	Material number	Name	Mat.	Num.	Remarks

					Draw	Ver.	Title	Drawing no.		Num.
					Desi	App.	SG-16N/20N			Mat.
					Check	by	BC Cyclone Support Rack (option)			
Mark	Before Mark	After Mod.	Modified by	Date	App.	Date	 信易電熱機械股份有限公司 Shini Plastics Technologies, Inc.			

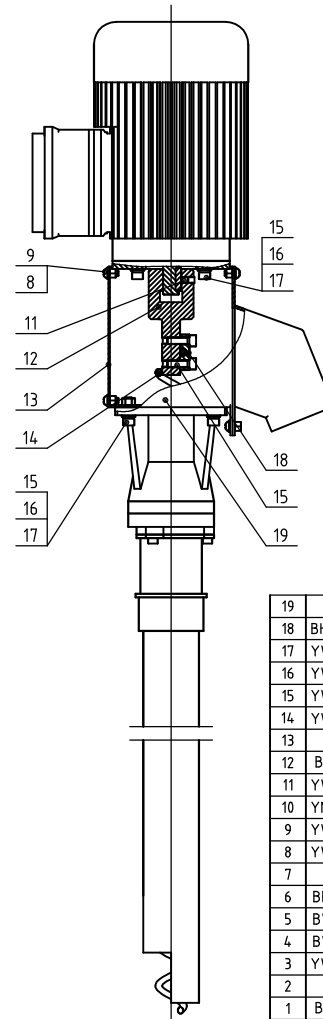
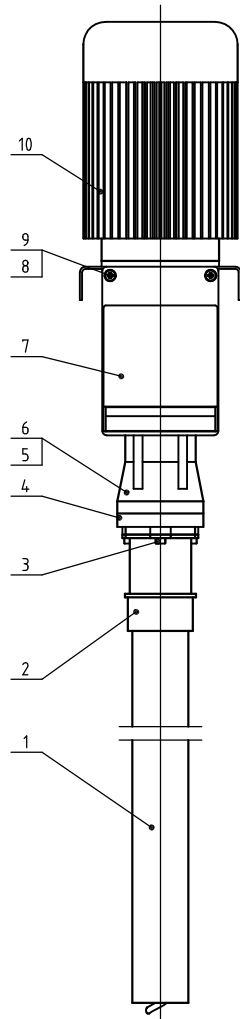

19	--	Transfer box	Welding assembly	1	
18	BH10503600010	Pressing block	SPH10.0	1	
17	YW66061300000	Flat washer 6	14.0HV	10	
16	YW65060000100	Spring washer 6	65Mn	10	
15	YW61062000300	Inner hex. column lead screw M6×20	2.9	10	
14	YW01162800600	Conveying spring	SWP-B	1	
13	--	Cover plate	SUS201 1.5	1	
12	BH101628004.40	Connecting shaft	Q235A	1	
11	YW68006600000	Inner hex. flat end lock screw M6×6	12.9	2	
10	YM507614.00000	Motor 0.18kW	Assembly	1	
9	YW66051000000	Flat washer 5	14.0HV	8	
8	YW62051000100	Cross recessed pan head screw M5×10	4.8	8	
7	--	Material outlet	SUS201 2.0	1	
6	BP20500300050	Pipe sleeve seal ring	Rubber	1	
5	BW20500000010	Pipe sleeve base	YL112	1	
4	BW20500000110	Pipe sleeve cover	YL112	1	
3	YW60054.0000000	Inner hex. screw M5×40	8.8	3	
2	--	Conveying pipe sleeve	Welding assembly	1	
1	BR90162800110	Conveying pipe	PA12	1	
No.	Material number	Name	Mat.	Num.	Remarks

Draw	Ver.	Title	Drawing no.	Scale	Num.
Desi.	App. by	Rotary Spring Conveyor (option)			Mat.
Check					
Mark	Before Mod.	After Mod.	Modified by.	Date	App.
		信易電熱機械股份有限公司 Shini Plastics Technologies, Inc.		Surface req.	
				Mat No.	

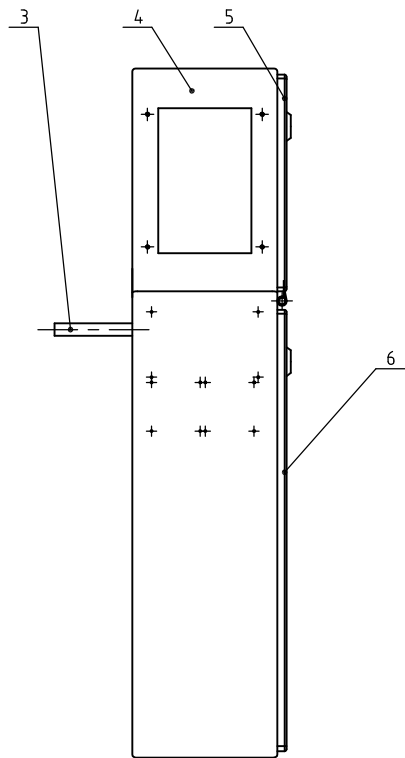
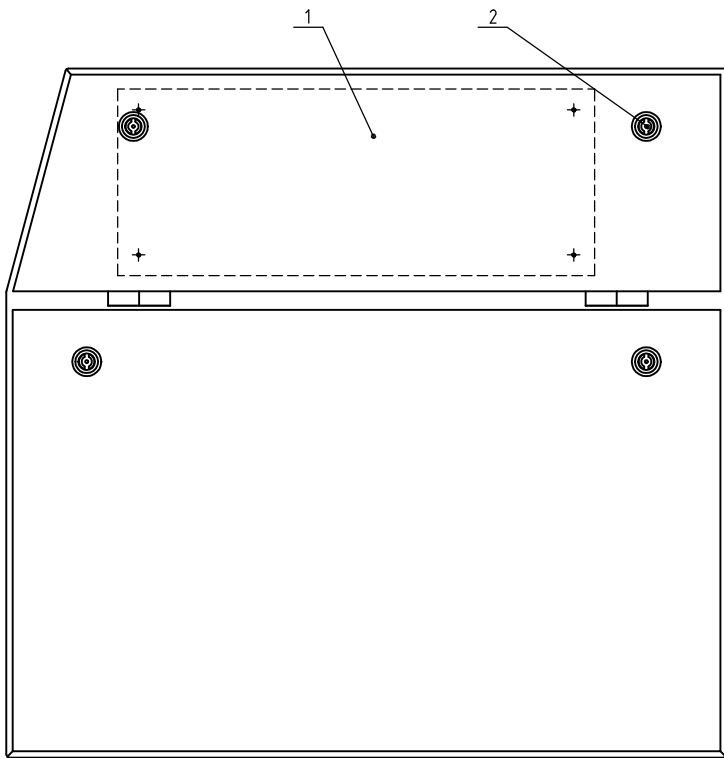

6	--	Shell lower cover plate	SPCC2.0	1	
5	--	Shell upper cover plate	SPCC2.0	1	
4	--	Shell	SPCC3.0	1	
3	--	Feed box support rod	Q235A	1	
2	YW0000000100	Long door lock		4	
1	--	Elec. mount plate	SPCC1.5	1	
No.	Material number	Name	Mat.	Num.	Remarks

					Draw.		Ver.	
					Desi.		App.	
					Check		by	
Mark	Before Mod.	After Mod.	Modified by	Date	App.		Date	

Title: SG-2028N(C)/2042N(C)		Drawing no.		Scale	Num.
Control box assembly				Mat.	
 信易電熱機械股份有限公司 Shini Plastics Technologies, Inc.				Surface req.	
				Mat No.	

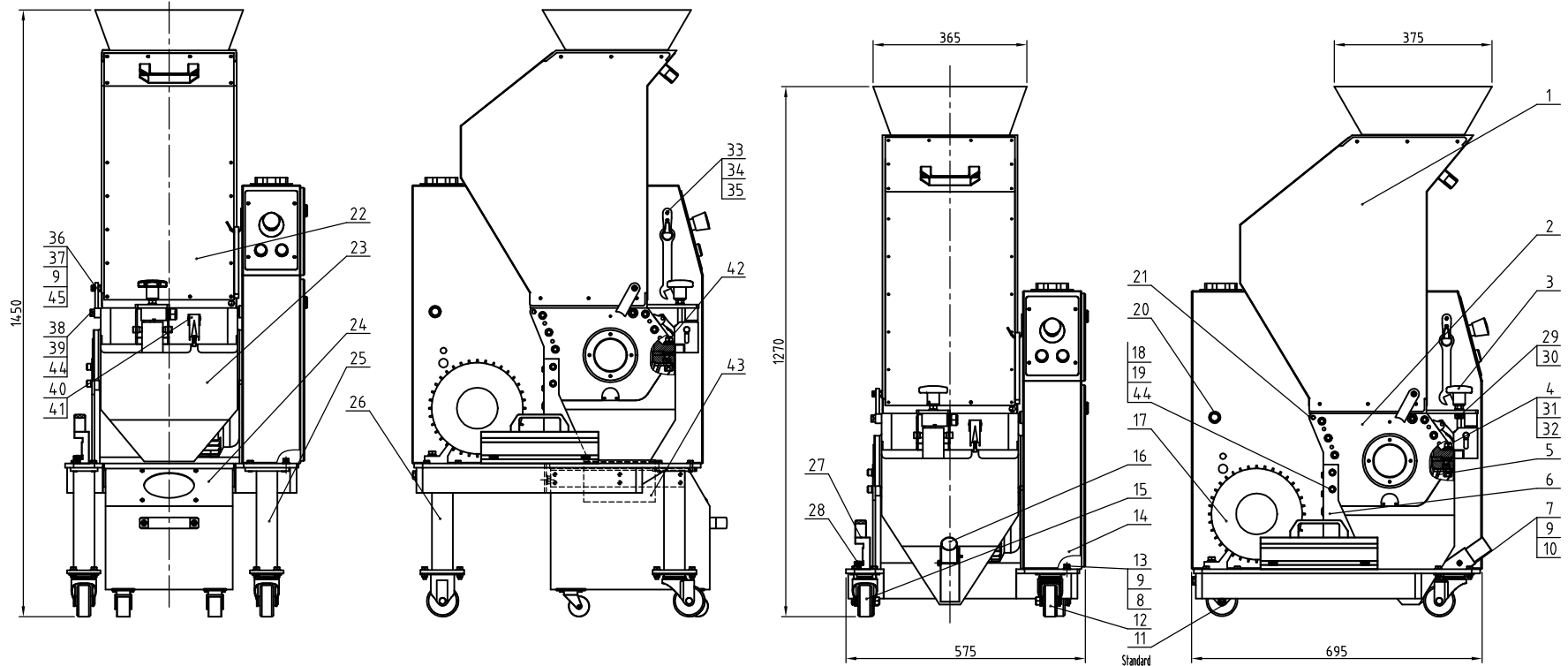

45	YW64080600000	Hex. nut GB/T6170 M8- Longzine	4	1	31	YW65012000000	Standard spring washer GB/T193 12-Longzine	65Mn	1	15	YW03000300200	Brake castor 3"	Assembly	1
44	YW66102500000	Flat washer 10x25x15- Longzine	4	2	30	YW68005500000	Hexagon socket set screw with flat end GB/T7086-Longzine	4.5H	1	14	--	Control box assembly	Assembly	1
43	BP82202800044	Filter cloth bag	Nylon mesh 400	1	29	BH11241000010	Screw lock screw nut	4	1	13	YW61081600000	Inner hex cylindrical head screw GB/T911 M8x12.9-Longzine	8.8	4
42	YW64012100000	Hex. nut GB/T6170 M2- Longzine	4	1	28	YW69621600000	Manual screw M6x20x16	Assembly	2	12	YW03000300000	Brake castor 3"	Assembly	1
41	YW62041000000	Large cross recessed flat head screw 8.8x16x1.8-Longzine	4.8	2	27	BW30202813310	Blade rest shaft	Assembly	1	11	YW03000300300	Fixed castor 3"	Assembly	2
40	YW02003000400	Snap hook	Assembly	1	26	--	Support foot 1	Q235A&SPH6.0	3	10	YW64080600000	Non-metal insert hex. lock nut GB/T10811M8	5	16
39	YW61102500000	Inner hex. flat head screw GB/T911 M8x5-12.9-Longzine	12.9	1	25	--	Support foot 2	Q235A&SPH6.0	1	9	YW66081900000	Flat washer 8x19x2.0 Longzine	14.0HV	21
38	BH10162804110	Limit block sleeve	Q235A	1	24	--	Storage box assembly	Assembly	1	8	YW65008000100	Flat washer 8x19x2.0 Longzine	65Mn	4
37	YW61083000000	Inner hex column head screw GB/T911 M8x12.9-Longzine	12.9	1	23	--	Storage hopper assembly	Assembly	1	7	YW60082500300	Hex. bolt GB/T5783 M8-25-12.9-Longzine	4.8	16
36	--	Limit block	SPH8.0	1	22	--	Feed box assembly	Assembly	1	6	--	Rack assembly	Assembly	1
35	JT10001806000	Short click pulley wrench 18	Q235A	1	21	YW61062000200	Inner hex cylindrical head screw GB/T911 M8x12.9-Longzine	12.9	4	5	--	Screen bracket assembly	Assembly	1
34	YW62041000000	Large cross recessed flat head screw 8.8x16x1.8-Longzine	4.8	2	20	YR40162800000	Rubber sleeve	PP	1	4	YW60128000000	Hex. bolt GB/T5782 M8x48-8.8-Longzine	8.8	1
33	YW90351800100	Small Head Flat Head Hexness Screw with 4mm Hex hole distance 18mm	4.8	1	19	YW65010000000	Standard spring washer GB/T193 10-Longzine	65Mn	7	3	BH10204208510	Feed box star assembly	Assembly	1
32	YW66122400000	Flat washer GB/T191 12- Longzine	4.8	1	18	YW61102000000	Inner hex cylindrical head screw GB/T911 M8x12.9-Longzine	12.9	4	2	--	Cutting chamber assembly	Assembly	1
					17	--	Gearing device	Assembly	1	1	--	Feed box assembly	Assembly	1
					16	--	Storage hopper assembly	Assembly	1	Standard				

制图	版号	标题	SG-2028N	图号		比例	数量
设计	核准	粉碎机总成				材质	表面要求
校对	标准	信易电热机械股份有限公司 Shini Plastics Technologies, Inc.					
标记	更改前	更改后	更改人	日期	审核	日期	

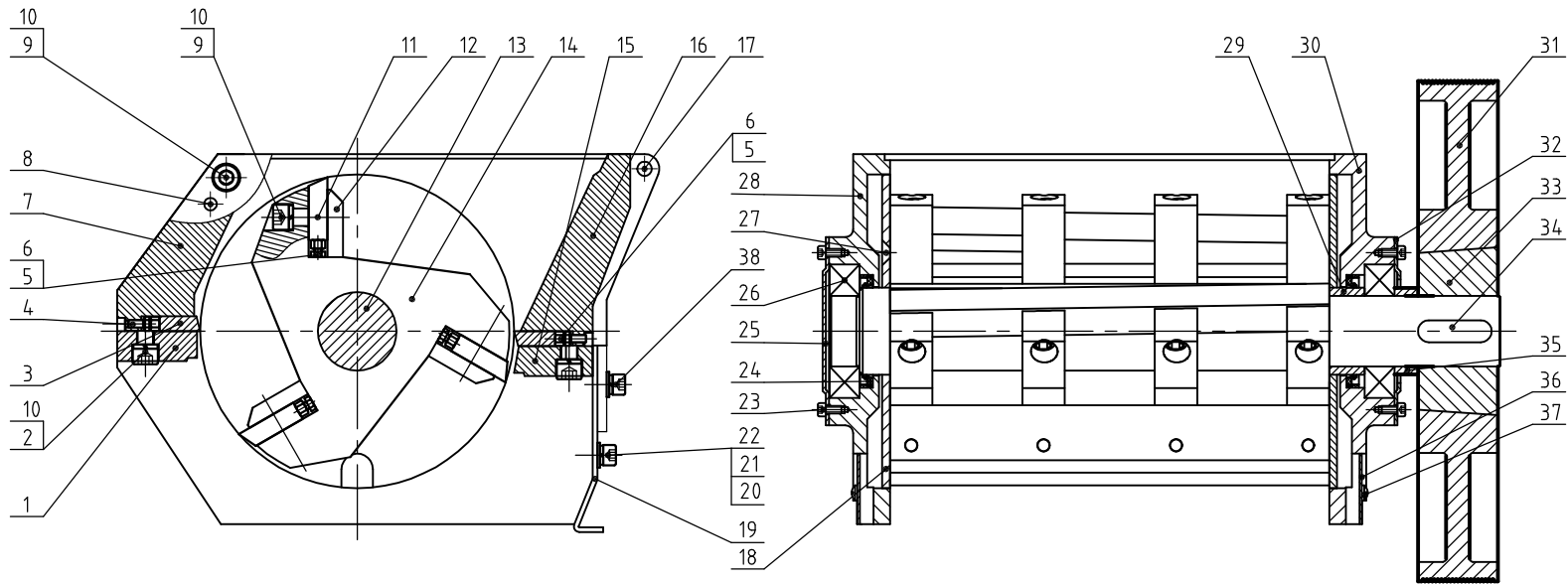

38	YW61082501200	Inner hex. column head screw GB/T91.1M5x12.9-Longzine		2		22	YW66081900000	Flat washer A grade GB/T97.1 8- Longzine	14.0HV	4		7	BW30202804540	Front box block	QT500-7	1				
37	YW63050800000	Cross recessed pan head screw GB/T 89.1M5x4-Longzine		4		21	YW65008000100	Standard spring washer GB/T93 8-Longzine	65Mn	4		6	YW64050800100	Hex. nut GB/T6170 M5-A2-70(SUS)		10				
36	--	Disc plate	SPCC1.5	2		20	YW61081600000	Inner hex. column head screw GB/T91.1M5x12.9-Longzine		2		5	YW60512880000	Hex. bolt GB/T5783 M5x12-8.8-Longzine		10				
35	BH12024203010	Shim1	Q235A	1		19	--	Storage box hanging plate	SPCC3.0	1		4	YW68051600000	Inner hex. flat end lock screw GB/T7716x6-Longzine		4				
34	BH11202400010	Flat key 14x9x4.6.5	45	1		18	BH11020020010	Fender plate	SK5	2		3	YW40202820000	Fixed blade	S45C&V-4E	2				
33	BW30002005520	Big taper sleeve SG-20-3020-45 HT250 (assembly)		1		17	BH10204100010	Rotating shaft	Q235A	2		2	YW61103000000	Inner hex. column head screw GB/T91.1M5x12.9-Longzine		6				
32	BL50204201820	Right bearing ext. cover plate	SPCC2.0	1		16	BW30202804640	Rear box block	QT500-7	1		1	BW30202813510	Rear box block pressing block	Q235A	1				
31	BW30001605120	Large ball wheel SG-20/2000-2000HT250 (assembly)		1		15	BW30202813710	Rear box block pressing block	Q235A	1		1	BW30202813510	Rear box block pressing block	Q235A	1				
30	BW30204207110	Right end plate	QT500-7	1		14	--	Blade rest	45	4		1	BW30202813510	Rear box block pressing block	Q235A	1				
29	BH10204500010	Shim	Q235A	1		13	BH11002028010	Blade rest shaft	45	1		No.	Material number	Name	Mat.	Num.	Remarks			
28	BW30204207010	Left end plate	QT500-7	1																
27	YW61082000100	Inner hex. countersink head screw GB/T91.1M5x12.9-Longzine		6								12	BH11202840410	Blade pressing plate	Q235A	3				
26	YW11620901800	Bearing 6209-2RS1		2	SKF							11	YW45161150000	Rotating blade	S45C&V-4E	3				
25	BL50204201320	Left bearing ext. cover plate	SPCC2.0	1								10	YW65010000000	Standard spring washer GB/T93 10-Longzine	65Mn	30				
24	YR80557200000	Oil seal φ77xφ55x8		2								9	YW61103500000	Inner hex. column head screw GB/T91.1M5x12.9-Longzine		24				
23	YW61051000000	Inner hex. column head screw GB/T91.1M5x12.9-Longzine		8								8	YW69083500000	Spring column pin GB/T 879.1 8x35	65Mn	8				
22	YW66081900000	Flat washer A grade GB/T97.1 8- Longzine		4								7	BW30202804540	Front box block	QT500-7	1				
21	YW65008000100	Standard spring washer GB/T93 8-Longzine		4								6	YW64050800100	Hex. nut GB/T6170 M5-A2-70(SUS)		10				
20	YW61081600000	Inner hex. column head screw GB/T91.1M5x12.9-Longzine		2								5	YW60512880000	Hex. bolt GB/T5783 M5x12-8.8-Longzine		10				
19	--	Storage box hanging plate	SPCC3.0	1								4	YW68051600000	Inner hex. flat end lock screw GB/T7716x6-Longzine		4				
18	BH11020020010	Fender plate	SK5	2								3	YW40202820000	Fixed blade	S45C&V-4E	2				
17	BH10204100010	Rotating shaft	Q235A	2								2	YW61103000000	Inner hex. column head screw GB/T91.1M5x12.9-Longzine		6				
16	BW30202804640	Rear box block	QT500-7	1								1	BW30202813510	Rear box block pressing block	Q235A	1				
15	BW30202813710	Rear box block pressing block	Q235A	1								1	BW30202813510	Rear box block pressing block	Q235A	1				
14	--	Blade rest	45	4								1	BW30202813510	Rear box block pressing block	Q235A	1				
13	BH11002028010	Blade rest shaft	45	1																
12	BH11202840410	Blade pressing plate	Q235A	3																
11	YW45161150000	Rotating blade	S45C&V-4E	3																
10	YW65010000000	Standard spring washer GB/T93 10-Longzine	65Mn	30																
9	YW61103500000	Inner hex. column head screw GB/T91.1M5x12.9-Longzine		24																
8	YW69083500000	Spring column pin GB/T 879.1 8x35	65Mn	8																
7	BW30202804540	Front box block	QT500-7	1																
6	YW64050800100	Hex. nut GB/T6170 M5-A2-70(SUS)		10																
5	YW60512880000	Hex. bolt GB/T5783 M5x12-8.8-Longzine		10																
4	YW68051600000	Inner hex. flat end lock screw GB/T7716x6-Longzine		4																
3	YW40202820000	Fixed blade	S45C&V-4E	2																
2	YW61103000000	Inner hex. column head screw GB/T91.1M5x12.9-Longzine		6																
1	BW30202813510	Rear box block pressing block	Q235A	1																

Draw.	Ver.
Desi.	App. by
Check	
App.	Date

Title SG-2028N
Drawing no.
Cutting Chamber Assembly

Scale Num.
Mat.
Surface req.
Mat No.



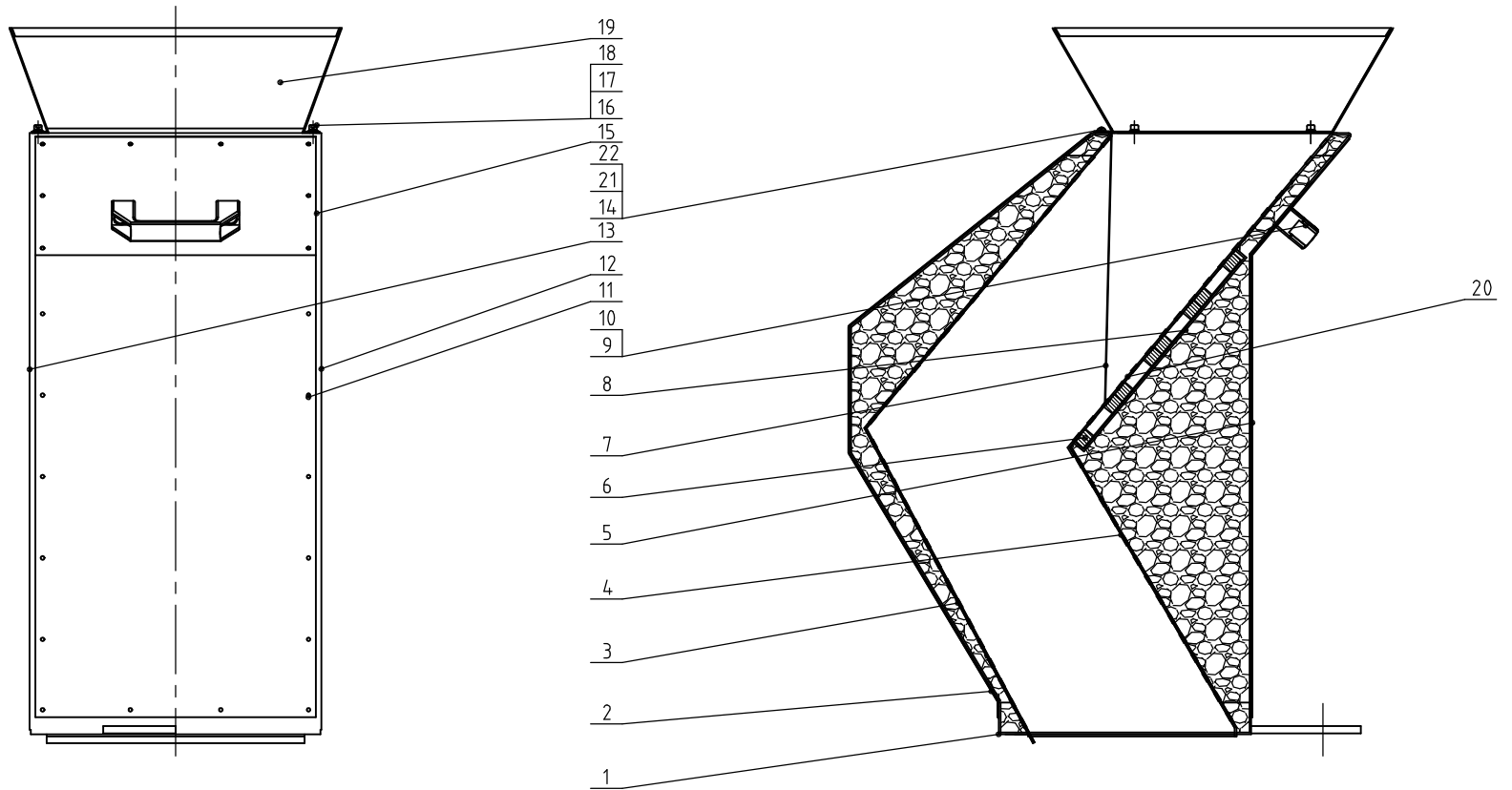

22	YW2051000100	Large recessed flat head screw JS 1111M5x10-Longline	12.9	3								
21	--	Fender plate pressing plate	SPCC1.5	1		10	YW61081600000	Inner hex column head screw M6x16	8.8	2		
20	--	Front inner plate 2	SUS201 2.0	1		9	BW20012000140	Handle L	Alum. alloy	1		
19	--	Feed part	SPCC1.5	1		8	--	Magnetic box	SUS201 1.2	1		
18	YW66051000000	Flat washer 5	140HV	4		7	--	Fender plate	Fender pressing plate	1		
17	YW65005200000	Spring washer 5	65Mn	4		6	YW90683200000	Magnet 68x32x12		16		
16	YW61051000000	Inner hex column head screw M5x10	12.9	4		5	--	Front guard plate	SPCC1.2	1		
15	--	Left & right inner plate	SECC2.0	2		4	--	Front inner plate 1	SECC2.0	1		
14	--	Hopper part	SPCC2.0	1		3	--	Rear inner plate	SECC2.0	1		
13	--	Left guard plate	SPCC1.2	1		2	--	Rear guard plate	SPCC1.2	1		
12	--	Right guard plate	SPCC1.2	1		1	--	Square base	SPCC3.0	1		
11	YW67481900000	Large recessed pan head tapping screw ST4.8x9		44		No.	Material number	Name	Mat.	Num.	Remarks	

					Draw.	Ver.	Title SG-2028N(C)		Drawing no.		Scale	Num.
					Desi.	App. by	Feed Box Assembly				Mat.	
					Check						Surface req.	
Mark	Before Mod.	After Mod.	Modified by.	Date	App.	Date	 信易電熱機械股份有限公司 Shini Plastics Technology, Inc.				Mat No.	

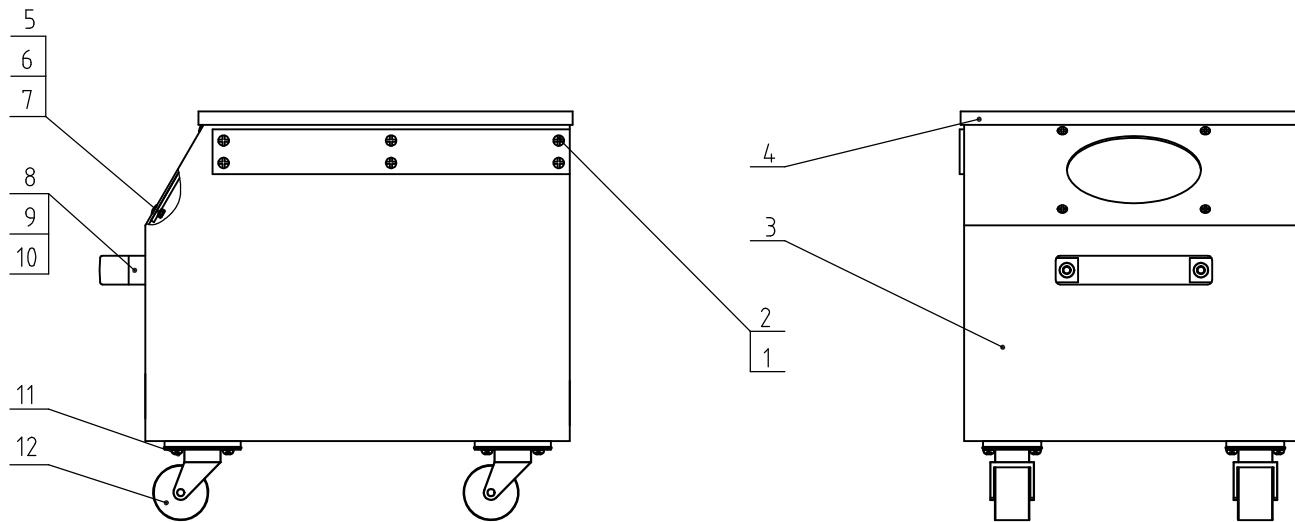

12	YW03000200000	Black castor 2'	Assembly	4	
11	YW62050500000	Large cross recessed flat head screw JS1111 M5x5	Longzine	16	
10	YW64000800100	Anti-loose nut M8	6	2	
9	YW61081600000	Inner hex. nut M8x16	8.8	2	
8	BW20012000140	Handle	Alum. alloy	1	
7	YW64040700100	Anti-loose nut M4	5	4	
6	YW62041000000	Large cross flat head screw JS1111 M4x10-Longzine	8.8	4	
5	--	Visual window transparent plate	Acrylic	1	
4	--	Storage box cover	SECC2.0	1	
3	--	Storage case	SECC2.0	1	
2	YW61040600000	Inner hex countersunk screw GB/T70.3 M4x6-12.9-Longzine	8.8	12	
1	BR90202800310	Fender plate	Teflon	2	
No.	Material number	Name	Mat.	Num.	Remarks

					Draw.		Ver.		Title	SG-2028N(C)	Drawing no.		Num.		
					Desi.		App.		Storage Box Assembly (option)				Mat.		
					Check		by		 信易電熱機械股份有限公司 Shini Plastics Technologies, Inc.						
Mark	Before Mark	After Mod.	Modified by	Date	App.		Date								

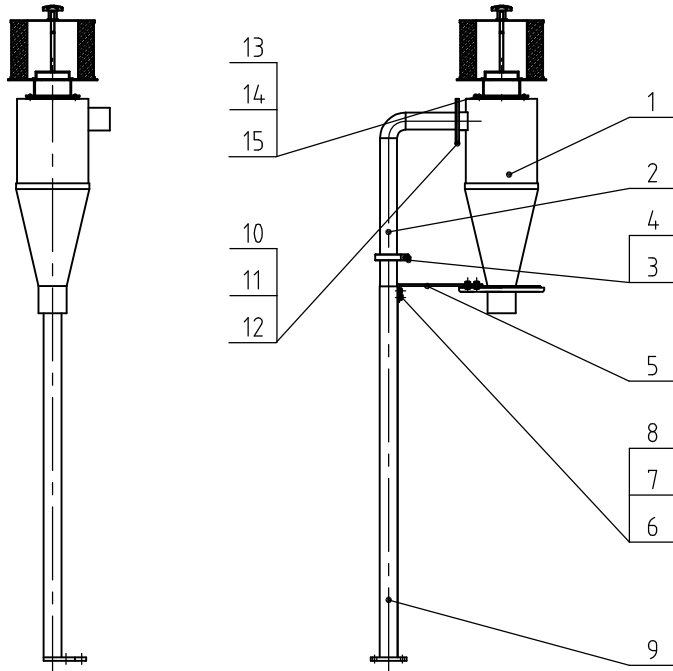

15	YW60512880000	Inner hex. bolt GB/T5783 M5x12-8.8-Longzine		4	
14	S00000000357	Simple filter	Assembly	1	
13	BL59160000121	Filter	Welding assembly	1	
12	YW65008000100	Standard spring washer GB/T93 8-Longzine		4	
11	YW66081900000	Flat washer 8x19x2.0 Longzine		4	
10	YW60081600100	Inner hex. bolt GB/T5781 M8x16-4.8-Longzine		4	
9	--	Lower support	Welding assembly	1	
8	YW65005200000	Standard spring washer GB/T93 5-Longzine	60Mn	2	
7	YW66051000000	Flat washer A grade GB/T97.15-Longzine	140HV	6	
6	YW61050600300	Inner hex. column head screw GB/T90.1 M6x16-2.9-Longzine		4	
5	--	Support plate	SPH4	1	
4	YR20001500000	Food connector seal ring 1.5"		1	
3	YW07001500500	1.5" food connector pipe clamp		1	
2	S000000000620	Upper support	Welding assembly	1	
1	S000000000966	Cycloner	Welding assembly	1	
No.	Material number	Name	Mat.	Num.	Remarks

					Draw		Ver.		Title	SG-16N/20N	Drawing no.		Num.
					Desi		App.		BC Cyclone Support Rack (option)				Mat.
					Check		by		信易電熱機械股份有限公司 Shini Plastics Technologies, Inc.				
Mark	Before Mark	After Mod.	Modified by	Date	App.		Date						

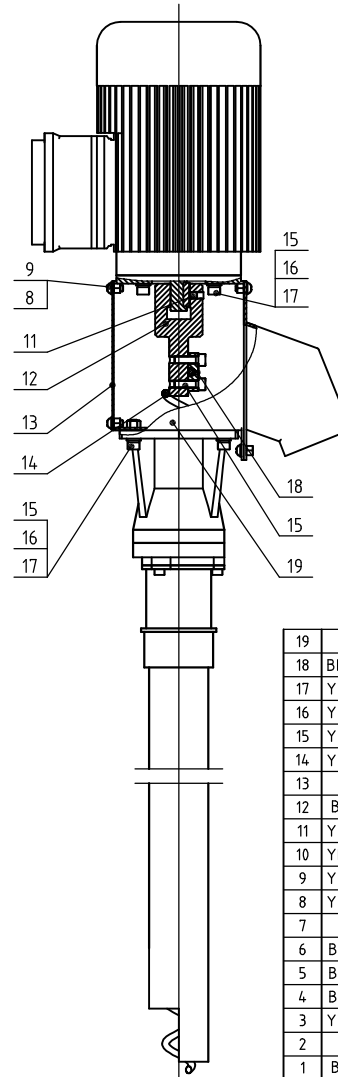
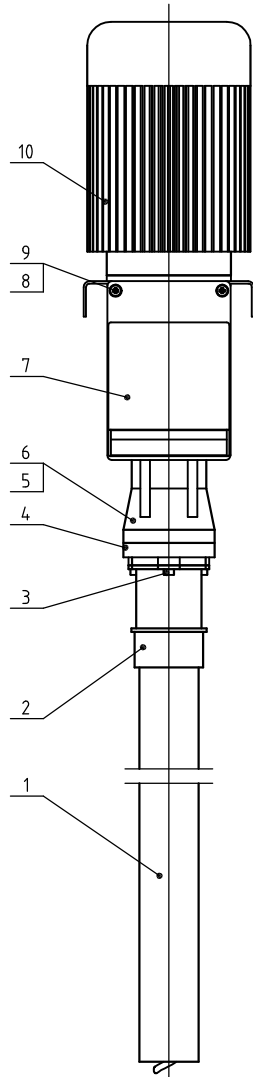

No.	Material number	Name	Mat.	Num.	Remarks
19	--	Transfer box	Welding assembly	1	
18	BH10503600010	Pressing block	SPH10.0	1	
17	YW66061300000	Flat washer 6	140HV	10	
16	YW65060000100	Spring washer 6	65Mn	10	
15	YW61062000300	Inner hex column head screw M6×20	12.9	10	
14	YW01162800600	Conveying spring	SWP-B	1	
13	--	Cover plate	SUS201 1.5	1	
12	BH101628004.4.0	Connecting shaft	Q235A	1	
11	YW68006600000	Inner hex flat end lock screw M6×6	12.9	2	
10	YM507614.00000	Motor 0.18kW	Assembly	1	
9	YW66051000000	Flat washer 5	140HV	8	
8	YW62051000100	Cross recessed pan head screw M5×10	4.8	8	
7	--	Material outlet	SUS201 2.0	1	
6	BP20500300050	Pipe sleeve seal ring	Rubber	1	
5	BW20500000010	Pipe sleeve base	YL112	1	
4	BW20500000110	Pipe sleeve cover	YL112	1	
3	YW60054.00000	Inner hex. screw M5×4.0	8.8	3	
2	--	Conveying pipe sleeve	Welding assembly	1	
1	BR90162800110	Conveying pipe	PA12	1	

Mark	Before Mod.	After Mod.	Modified by	Date	App.	Date

Draw.	Ver.	Title	Drawing no.	Scale	Num.
Desi.	App. by	SG-16N/20N			
Check		Rotary Spring Conveyor (option)			
App.	Date	 信易電熱機械股份有限公司 Shini Plastics Technologies, Inc.		Surface req.	
				Mat. No.	

Standard weight (kg)	Noise during granulating dB(A)	Max. cutting ability(kg/hr)	Cutting chamber size (mm)	Rotating Blade Qty.	Fixed Blade Qty.	Cutter Blade	Max. shaft rotation rpm	Motor power(KW)	(Ver. No.)
300(315)	85~90	135	200×420	3	2	SKD11	290	3.0(4.0)	Ver.F

Additional drawing

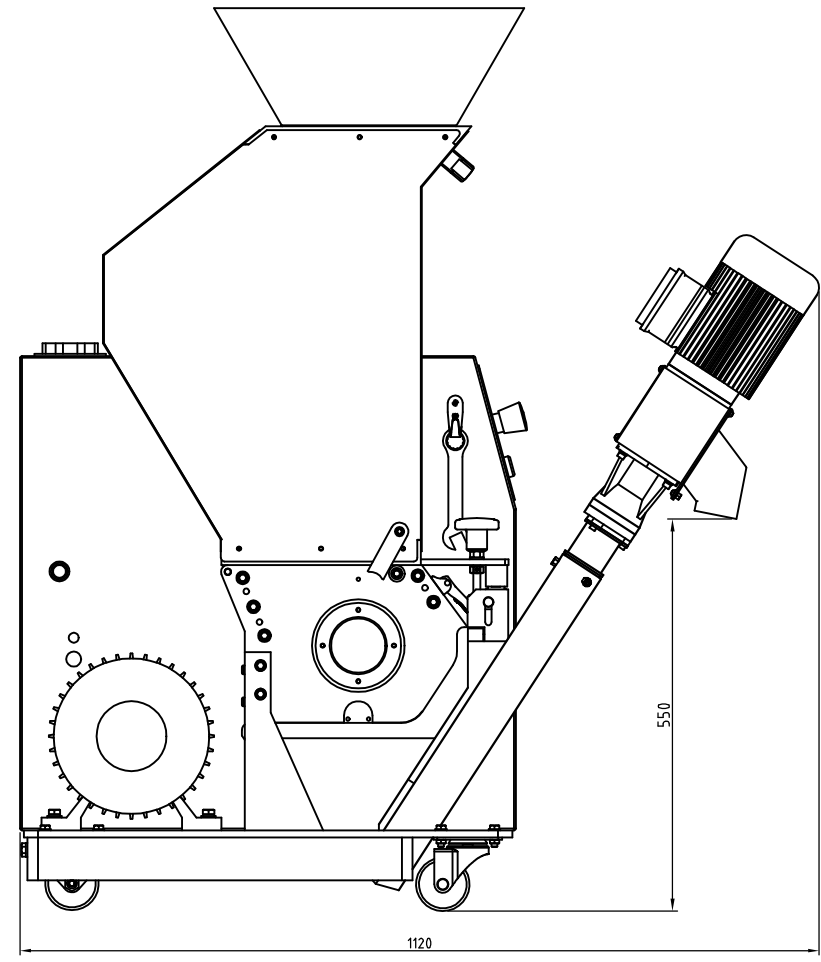

Notes: 1) The max. cutting capacity depends on the material size and crushed material;
 2) The noise when granulating is different due to the configuration of crushed materials and motor;
 3) SKD11 Japan JIS standard;
 4) To avoid material sticking the blade, all materials to be crushed shall be crushed at normal temp.;
 5) Machine power: 3 ϕ 400VAC,50Hz;
 6) The values in the brackets are for the optional large motor power model of SG-2042NH.

Optional spring conveyor

					制图	版号	标题	图号	比例	数量
					设计	核	SG-2042N		材质	
					校对	准	粉碎机总成			
					审核	日期	信易智能科技有限公司 Shini Plastics Technologies, Inc.	表面要求		
标记	更改前	更改后	更改人	日期				物料号		

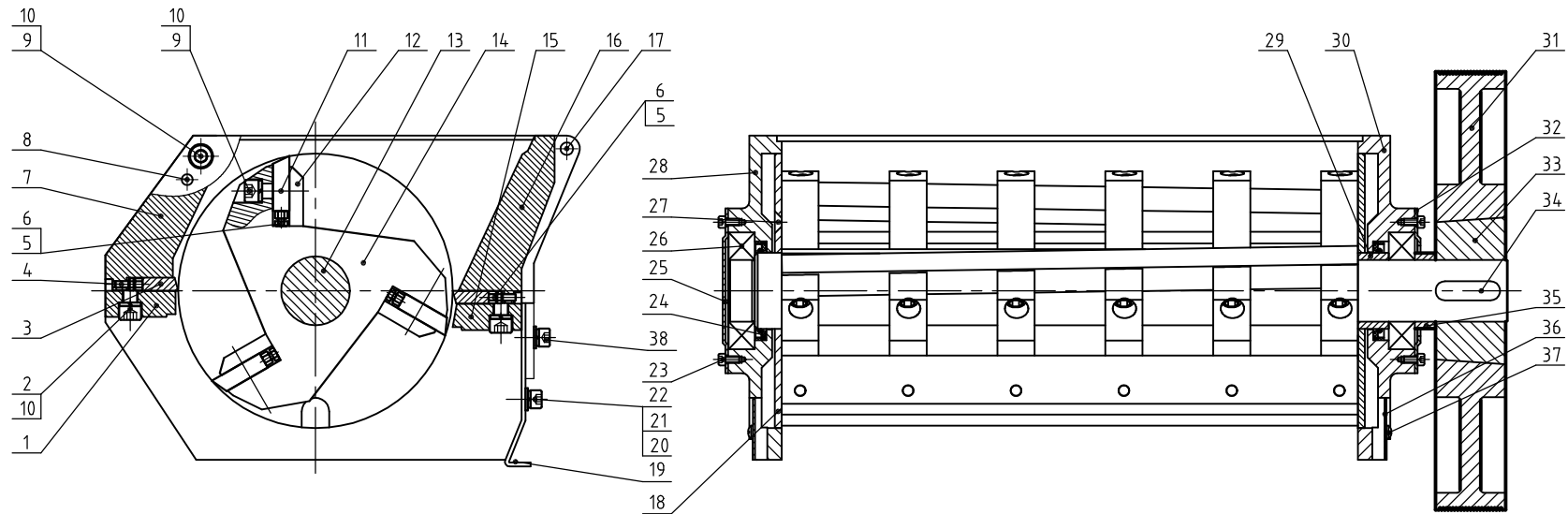

38	YW61082501200	Inner hex column head screw GB/T11190.3-12.9-Longzine		2		27	YW61081200100	Inner hex countersunk head screw GB/T11190.2-12.9-Longzine		6		12	BH11204.250010	Blade pressing plate	Q235A	3	
37	YW63050800000	Cross recessed pan head screw GB/T40160.8-Longzine		4		26	YW11620901800	Bearing 6209-2RS1		2	SKF	11	YW43204.2000000	Rotating blade	SKD11	3	
36	--	Clamp plate	SPCC1.5	2		25	BL50204.201320	Left bearing ext. cover plate	SPCC2.0	1		10	YW65010000000	Standard spring washer GB/T193.11-Longzine			38
35	BH10204.203010	Sleeve 1	Q235A	1		24	YR80557200000	Oil seal $\phi 72 \times \phi 55 \times 8$		2		9	YW61103500000	Inner hex column head screw GB/T11190.3-12.9-Longzine			38
34	BH112024.00010	Flat key 14 \times 9 \times 4.6.5	45	1		23	YW61051000000	Inner hex column head screw GB/T11190.3-12.9-Longzine		8		8	YW69083500000	Spring column pin GB/T 879.1 8 \times 35	65Mn	8	
33	BW30002005520	Big taper sleeve SG-20-3020-45 H7/G6 (assembly)		1		22	YW66081900000	Flat washer A grade GB/T 97.1 8		4		7	BW30204.213410	Front box block	QT500-7	1	
32	BL50204.201820	Right bearing ext. cover plate	SPCC2.0	1		21	YW65008000100	Standard spring washer GB/T193.8-Longzine		4		6	YW64.050800100	Hex. nut GB/T6170 M5-A2-70(SUS)			10
31	BW30001605120	Large ball wheel SG-20-3020-45 H7/G6 (assembly)		1		20	YW61081600000	Inner hex column head screw GB/T11190.3-12.9-Longzine		2		5	YW60512880000	Hex. bolt GB/T5783 M5 \times 12-8.8-Longzine			10
30	BW30204.207110	Right end plate	QT500-7	1		19	--	Storage box hanging plate	SPCC3.0	1		4	YW68051600000	Inner hex flat end lock screw GB/T11190.4-Longzine			4
29	BH10204.500010	Sleeve	Q235A	1		18	BH11020020010	Feeder plate	SK5	2		3	YW41204.200600	Fixed blade	SKD11	2	
28	BW30204.207010	Left end plate	QT500-7	1		17	BH10204.100010	Rotating shaft	Q235A	2		16	BW30204.213610	Rear box block	QT500-7	1	
						16	BW30204.213610	Rear box block	QT500-7	1		2	YW61103000000	Inner hex column head screw GB/T11190.3-12.9-Longzine			8
						15	BW30204.213710	Rear box block pressing block	Q235A	1		1	BW30204.213510	Front box block pressing block	Q235A	1	
						14	--	Blade rest	45	6		No.	Material number	Name	Mat.	Num.	Remarks
						13	BH11204.260010	Blade rest shaft	45	1							

Draw.	Ver.	Title	SG-204.2N	Drawing no.	Scale	Num.
Desi.	App. by	Cutting Chamber Assembly				Mat.
Check	Date	SHINI 信易電熱機械股份有限公司 Shini Plastics Technologies, Inc.		Surface req.		
Mark	Before Mod.	After Mod.	Modified by	Date	App.	Mat No.

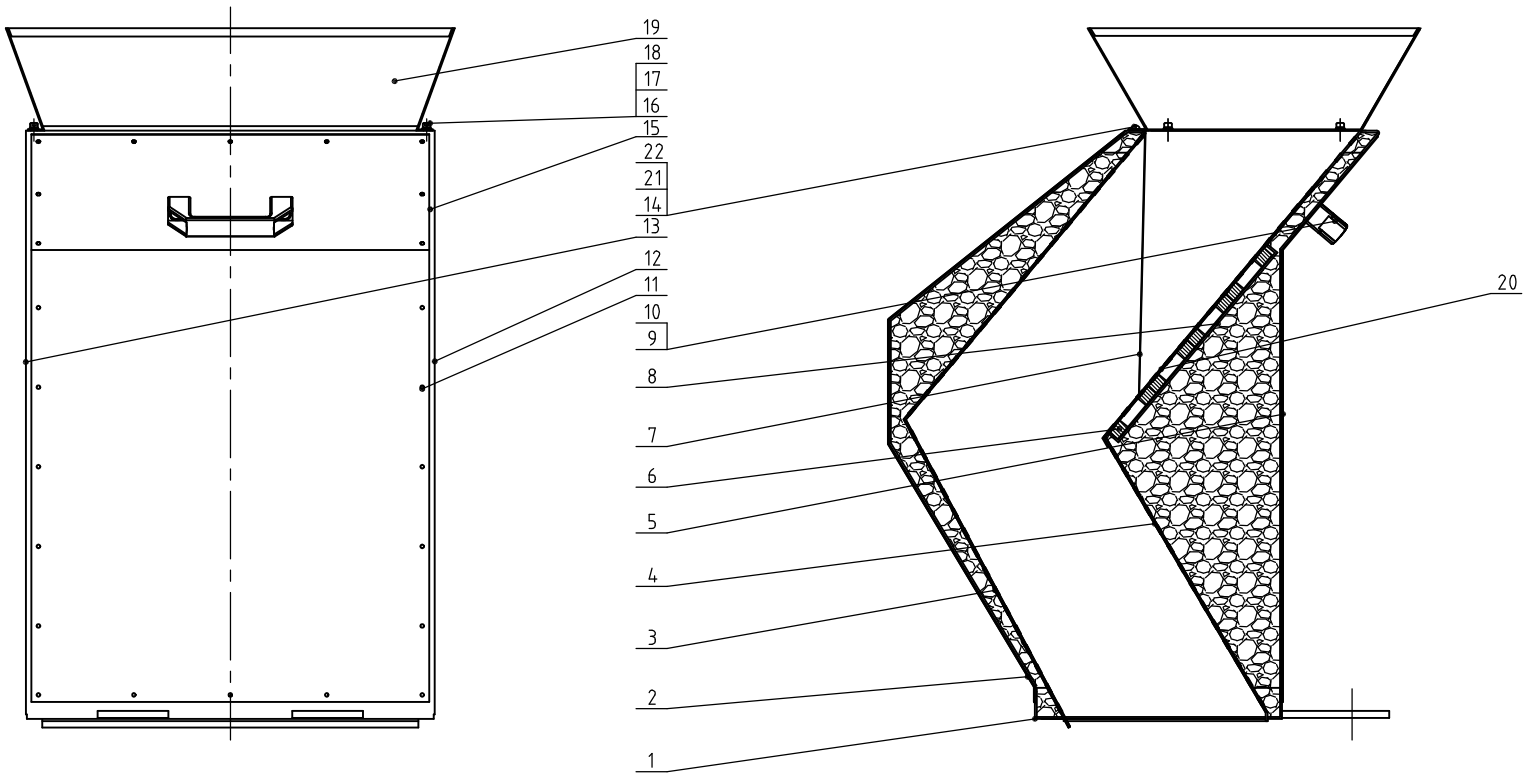

22	YW62051000100	Large recessed flat head screw JS M11 M5-0-Longline	12.9	3									
21	--	Fender plate pressing plate	SPCC1.5	1		10	YW61081600000	Inner hex. column head screw M6x6	12.9	2			
20	--	Front inner plate 2	SUS201 2.0	1		9	BW20012000140	Handle	Alum. alloy	1			
19	--	Feed part	SPCC1.5	1		8	--	Magnetic box	SPCC1.2	1			
18	YW66051000000	Flat washer 5	140HV	4		7	--	Fender plate	wire water-proof doth	1			
17	YW65005200000	Spring washer 5	65Mn	4		6	YW90683200000	Magnet 68x32x12		24			
16	YW61051000000	Inner hex. column head screw M5x10	12.9	4		5	--	Front guard plate	SPCC1.2	1			
15	--	Left & right inner plate	SECC2.0	2		4	--	Front inner plate 1	SECC2.0	1			
14	--	Hopper part	SPCC2.0	1		3	--	Rear inner plate	SECC2.0	1			
13	--	Left guard plate	SPCC1.2	1		2	--	Rear guard plate	SPCC1.2	1			
12	--	Right guard plate	SPCC1.2	1		1	--	Square base	SPCC3.0	1			
11	YW674.81900000	Large recessed pan head tapping screw S14.8x19		4.8									

Mark	Before Mod.	After Mod.	Modified by	Date	App.	Date	Draw.	Ver.	Title	Draw. no.	Scale	Num.	Remarks
									SG-2042N(C)				
									Feed Box Assembly				

SHINI 信易電熱機械股份有限公司
Shini Plastics Technology, Inc.

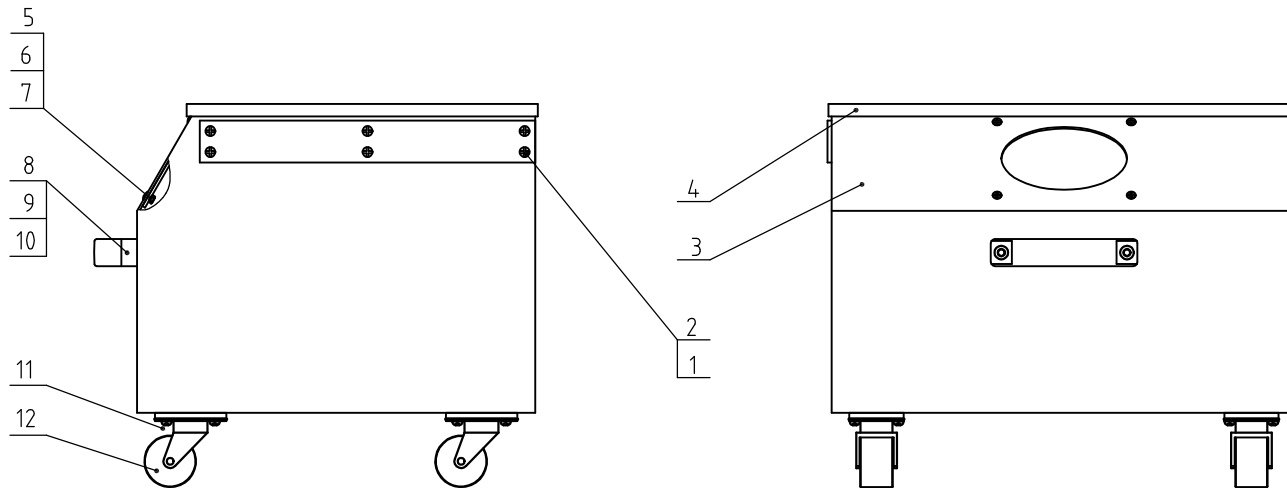

12	YW03000200000	Black castor 2'	Assembly	4	
11	YW62050500000	Large cross recessed flat head screw JS1111 M5x5	Longzine	16	
10	YW64000800100	Anti-loose nut M8	6	2	
9	YW61081600000	Inner hex. nut M8x16	8.8	2	
8	BW20012000140	Handle	Alum. alloy	1	
7	YW64040700100	Anti-loose nut M4	5	4	
6	YW62041000000	Large cross flat head screw JS1111 M4x10-Longzine	8.8	4	
5	--	Visual window transparent plate	Acrylic	1	
4	--	Storage box cover	SECC2.0	1	
3	--	Storage case	SECC2.0	1	
2	YW61040600000	Inner hex. countersunk screw GB/T703 M4x6-12.9-Longzine	8.8	12	
1	BR90202800310	Fender plate	Teflon	2	borrowed
No.	Material number	Name	Mat.	Num.	Remarks

					Draw.		Ver.		Title	SG-2042N(C)	Drawing no.			Num.	
					Desi.		App.		Storage Box Assembly (option)					Mat.	
					Check		by		 信易電熱機械股份有限公司 Shini Plastics Technologies, Inc.						
Mark	Before Mark	After Mod.	Modified by.	Date	App.		Date								

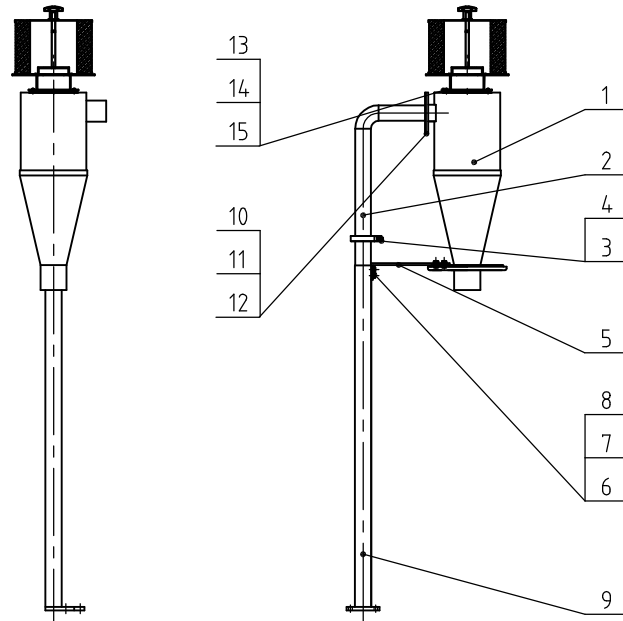

15	YW60512880000	Inner hex. bolt GB/T5783 M5x12-8.8-Longzine		4	
14	S000000000357	Simple filter	Assembly	1	
13	BL59160000121	Filter	Welding assembly	1	
12	YW65008000100	Standard spring washer GB/193 8-Longzine		4	
11	YW66081900000	Flat washer 8x19x2.0 Longzine		4	
10	YW60081600100	Inner hex. bolt GB/T5781 M6x16-4.8-Longzine		4	
9	--	Lower support	Welding assembly	1	
8	YW65005200000	Standard spring washer GB/193 5-Longzine	60Mn	2	
7	YW66051000000	Flat washer A grade GB/T97.15-Longzine	14.0HV	6	
6	YW61050600300	Inner hex. column head screw GB/T91.15x6-12.9-Longzine		4	
5	--	Support plate	SPH4	1	
4	YR20001500000	Food connector seal ring 1.5"		1	
3	YW07001500500	1.5" food connector pipe clamp		1	
2	S000000000620	Upper support	Welding assembly	1	
1	S000000000966	Cycloner	Welding assembly	1	
No.	Material number	Name	Mat.	Num.	Remarks

					Draw.	Ver.	Title	Drawing no.		Num.
					Desi.	App	SG-16N/20N			
					Check	by	BC Cyclone Support Rack (option)			Mat.
Mark	Before Mark	After Mod.	Modified by	Date	App.	Date	信易電熱機械股份有限公司 Shini Plastics Technologies, Inc.			

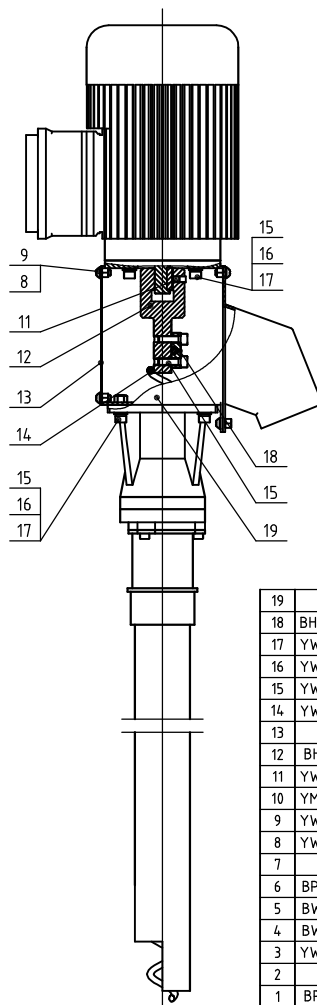
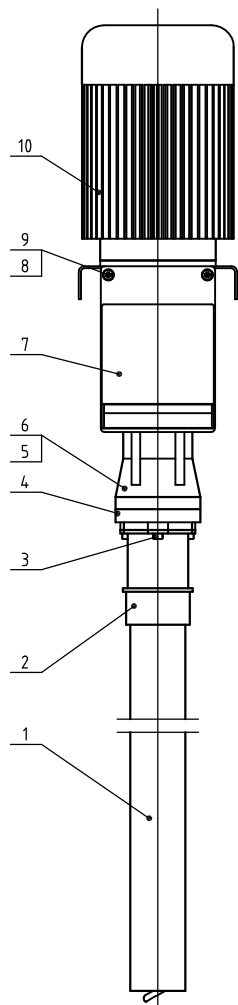

No.	Material number	Name	Mat.	Num.	Remarks
19	--	Transfer box	Welding assembly	1	
18	BH10503600010	Pressing block	SPH10.0	1	
17	YW66061300000	Flat washer 6	14.0HV	10	
16	YW65060000100	Spring washer 6	65Mn	10	
15	YW61062000300	Inner hex. column head screw M6×20	2.9	10	
14	YW01162800600	Conveying spring	SWP-B	1	
13	--	Cover plate	SUS201 1.5	1	
12	BH10162800440	Connecting shaft	Q235A	1	
11	YW68006600000	Inner hex. flat end lock screw M6×6	12.9	2	
10	YM507614.00000	Motor 0.18kw	Assembly	1	
9	YW66051000000	Flat washer 5	14.0HV	8	
8	YW62051000100	Cross recessed pan head screw M5×10	4.8	8	
7	--	Material outlet	SUS201 2.0	1	
6	BP20500300050	Pipe sleeve seal ring	Rubber	1	
5	BW20500000010	Pipe sleeve base	YL112	1	
4	BW20500000110	Pipe sleeve cover	YL112	1	
3	YW60054.00000	Inner hex. screw M5×40	8.8	3	
2	--	Conveying pipe sleeve	Welding assembly	1	
1	BR90162800110	Conveying pipe	PA12	1	

Draw	Ver.	Title	SG-16N/20N	Drawing no.	Scale	Num.
Desi.	App. by	Rotary Spring Conveyor (option)		信易電熱機械股份有限公司 Shini Plastics Technologies, Inc.	Surface req.	Mat.
Check	Date	App.	Date			
Mark	Before Mod.	After Mod.	Modified by	Date	App.	Date

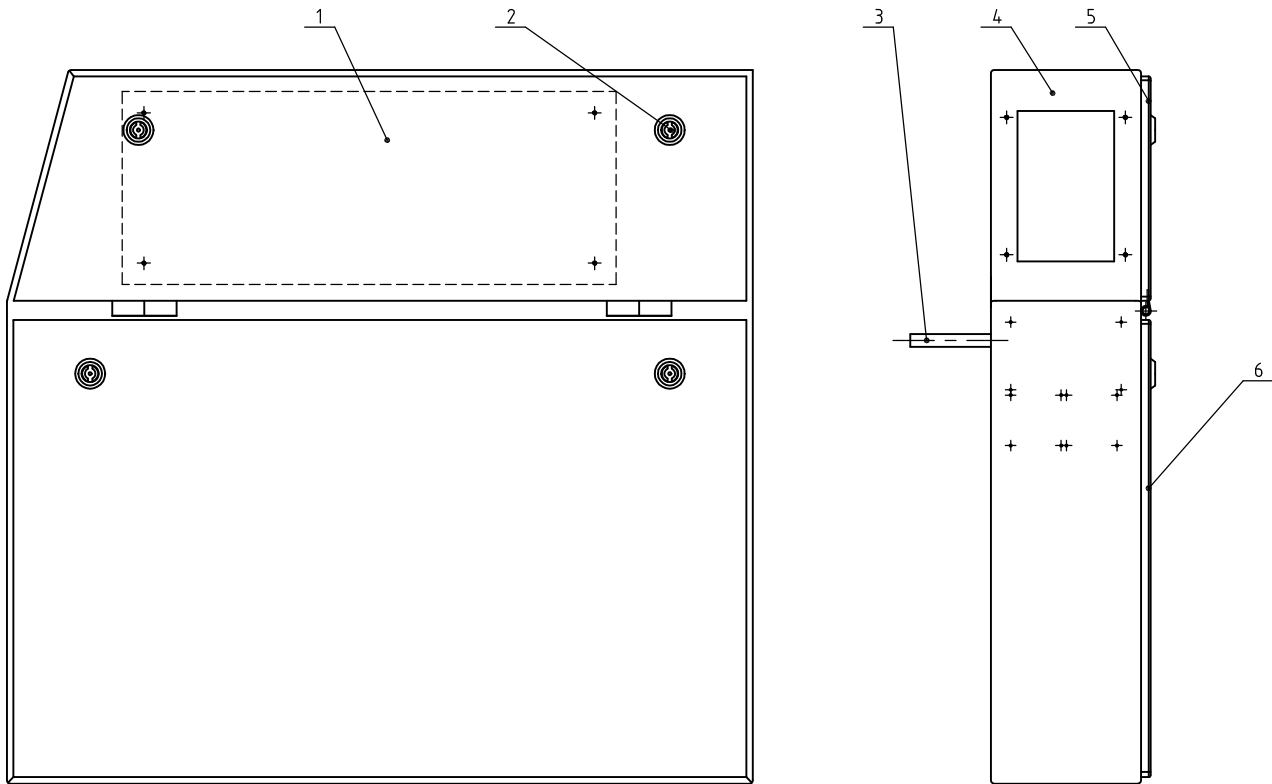

6	--	Shell lower cover plate	SPCC2.0	1	
5	--	Shell upper cover plate	SPCC2.0	1	
4	--	Shell	SPCC3.0	1	
3	--	Feed box support rod	Q235A	1	
2	YW0000000100	Long door lock		4	
1	--	Elec. mount plate	SPCC1.5	1	
No.	Material number	Name	Mat.	Num.	Remarks

					Draw.		Ver.		Title	SG-2028N(C)/2042N(C)	Drawing no.	Scale		Num.	
					Desi.		App		Control box assembly				Mat.		
					Check		by		SHINI 信易電熱機械股份有限公司 Shini Plastics Technologies, Inc.		Surface req.				
Mark	Before Mod.	After Mod.	Modified by.	Date	App.		Date					Mat No.			

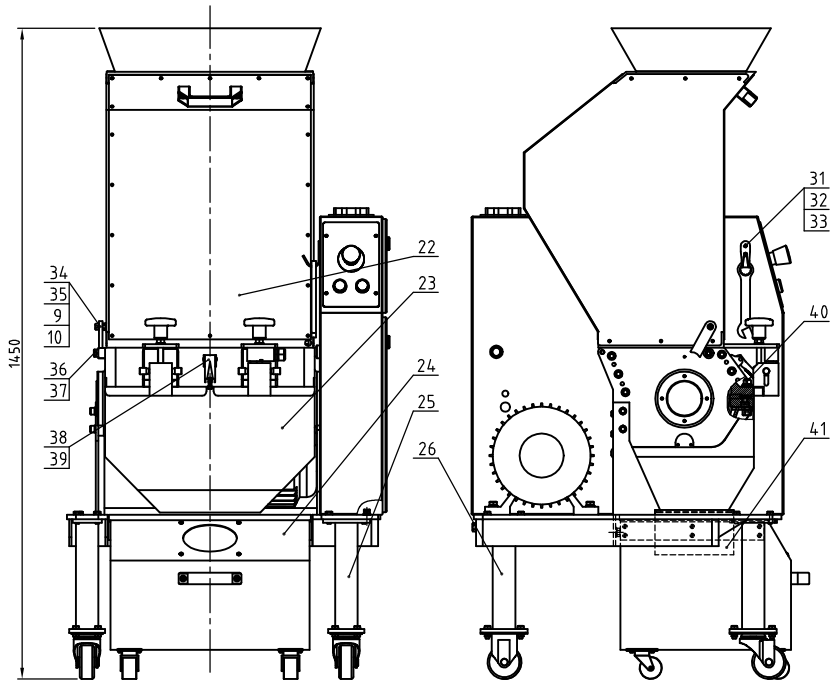

Optional high storage box

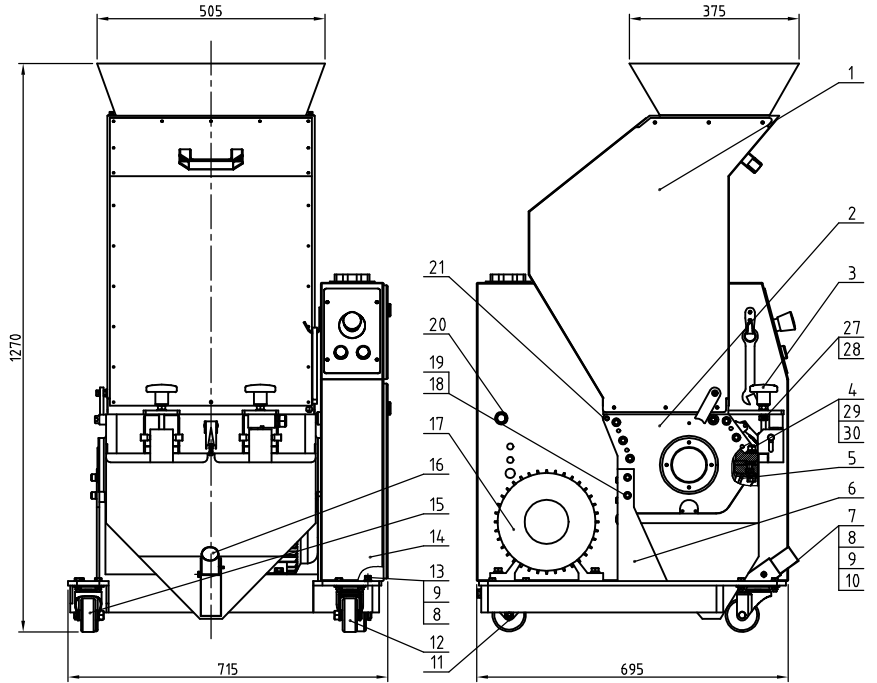

Standard

41	BP82204200044	Filter cloth bag	Nylon mesh 400	1		29	YW65012000000	Standard spring washer GB/T93 12-Longzine	65Mn	2		14	--	Control box assembly	Assembly	1	
40	YW64012100000	Hex. nut GB/T6170 M12- Longzine		2		28	YW68005500000	Hexage socket set screw with flat end GB/T7786-6-Longzine	45H	2		13	YW61081600000	Inner hex cylindrical head screw GB/T917M16x19-2.5-Longzine		4	
39	YW62041000000	Large cross recessed flat head screw GB/T14181.1-Longzine		2		27	BH11241000010	Screw lock screw nut	4	2		12	YW03000300000	Brake castor 3"	Assembly	1	
38	YW02003000400	Snap hook	Assembly	1		26	--	Support foot 1	Q235A&SPH6.0	3	Optional large storage hopper	11	YW03000300300	Fixed castor 3"	Assembly	2	
37	YW61102500000	Inner hex column head screw GB/T917M16x19-2.5-Longzine		1		25	--	Support foot 2	Q235A&SPH6.0	1	Optional large storage hopper	10	YW64000800100	Non-metal insert hex. lock nut GB/T8881M8		16	
36	BH10162804110	Limit block sleeve	Q235A	1		24	--	Storage box assembly	Assembly	1	Optional large storage hopper	9	YW66081900000	Flat washer 8x19-2.0 Longzine		21	
35	YW61083000000	Inner hex column head screw GB/T917M16x19-2.5-Longzine		1		23	--	Storage hopper assembly	Assembly	1	Optional large storage hopper	8	YW65008000100	Standard spring washer GB/T93 8-Longzine	65Mn	4	
34	--	Limit block	SPH8.0	1		22	--	Feed box assembly	Assembly	1	Optional large storage hopper	7	YW60082500100	Hex. bolt GB/T5783 M8x25-12.9-Longzine		16	
33	JT10001806000	Short click pulley wrench 18	Q235A	1		21	YW61062001200	Inner hex cylindrical head screw GB/T917M16x19-2.5-Longzine		4		6	--	Rack assembly	Assembly	1	
32	YW62041000000	Large cross recessed flat head screw GB/T14181.1-Longzine		2		20	YR40162800000	Rubber sleeve	PP	1		5	--	Screen bracket assembly	Assembly	1	
31	YW90351800100	Small head 4 mm thickness 3mm hole dia. 5mm hole distance 8mm		1		19	YW65010000000	Standard spring washer GB/T93 10-Longzine	65Mn	7		4	YW60128000000	Hex. bolt GB/T5782 M10x40-8.8-Longzine		2	
30	YW66122400000	Flat washer GB/T971.12- Longzine		2		18	YW61102000000	Inner hex cylindrical head screw GB/T917M16x19-2.5-Longzine		4		3	BH10204208510	Feed box star assembly	Assembly	2	
						17	--	Gearing device	Assembly	1		2	--	Caking chamber assembly	Assembly	1	
						16	--	Storage hopper assembly	Assembly	1	Standard	1	--	Feed box assembly	Assembly	1	
						15	YW03000300200	Movable castor 3"	Assembly	1		No.	Code	Name	Mat.	Qty.	Remark

制图	版号	标题	图号	比例	数量
设计	核准	SG-2042NC		1:1	1
校对	核准	粉碎机总成		表面要求	材质
审核	核准	SHINI 信易电热机械股份有限公司 Shini Plastics Technologies, Inc.		物料号	
标记	更改前	更改后	更改人	日期	日期

Additional drawing

Standard weight (kg)	Noise during granulating dB(A)	Max. cutting ability(kg/hr)	Cutting chamber size (mm)	Rotating Blade Qty.	Fixed Blade Qty.	Cutter Blade	Max. shaft rotation(r.p.m)	Motor power(KW)	(Ver. No.)
320(335)	85~90	135	200×420	18	2	SKD11	290	3.0(4.0)	Ver.F

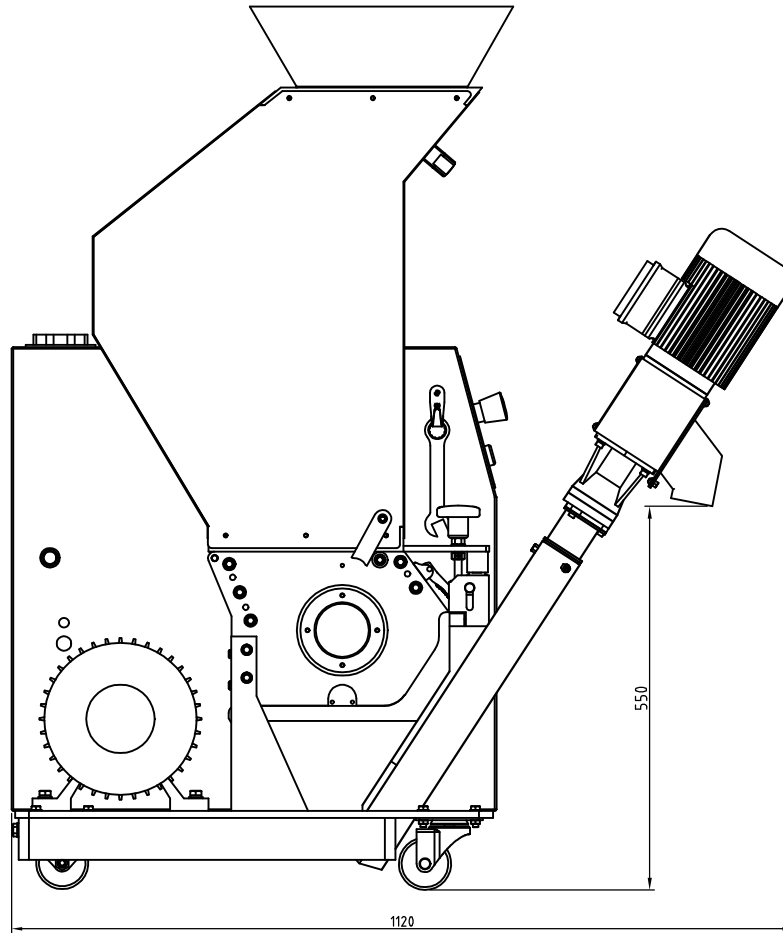

Optional spring conveyor

- Notes: 1) The max. cutting capacity depends on the material size and crushed material;
 2) The noise when granulating is different due to the configuration of crushed materials and motor.
 3) SKD11 Japan JIS standard;
 4) To avoid material sticking the blade, all materials to be crushed shall be crushed at normal temp.;
 5) Machine power: 3ø,400VAC,50Hz;
 6) The values in the brackets are for the optional large motor power model of SG-2042NCH.

					制图	版号	标题	图号	比例	数量
					设计	核准	SG-2042NC		1:1	1
					校对		粉碎机总成		表面要求	材质
标记	更改前	更改后	更改人	日期	审核	日期	SHINI 信易电热机械股份有限公司 Shini Plastics Technologies, Inc.		物料号	

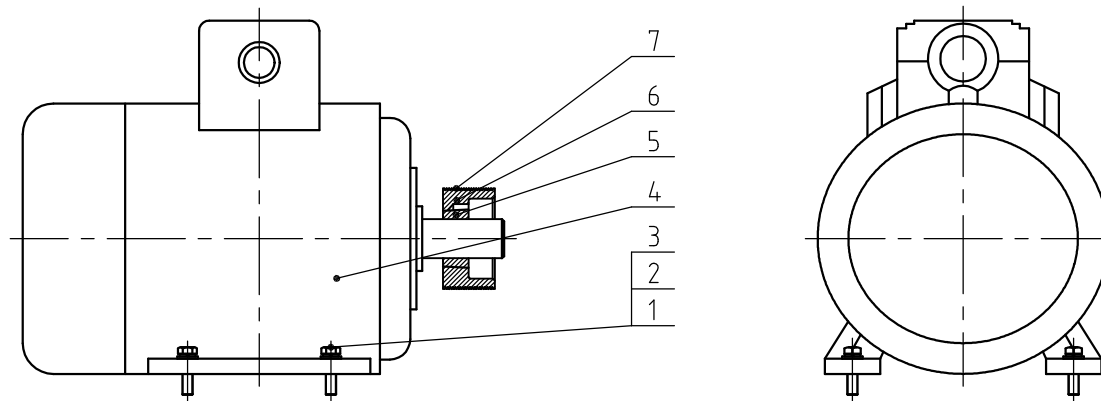

7	YW30205400000	Poly V-belt 20 PJ 54"		1	
6	BW30002005220	Small belt pulley SG-20-P20P180/3-600 H1250 (assembly)		1	
5	BW30002005420	Small taper sleeve SG-20-1610-38 H1250 (assembly)		1	
4	YM10203000600	Motor W20 3kW-132S-6P B3R IE3 230/400/460V		1	
3	YW66102500000	Flat washer 10x25x15-Longzine	14.0HV	4	
2	YW65010000000	Motor W20 3kW-132S-6P B3R IE3 230/400/460V	65Mn	4	
1	YW60104000100	Hex bolt GB/T5783 M10x40-8.8-Longzine		4	
No.	Material number	Name	Mat.	Num.	Remarks

					Draw.	Ver.	Title	Drawing no.	Scale	Num.
					Desi.	App.	Actuating Device			Mat.
					Check	by	信易電熱機械股份有限公司 Shini Plastics Technologies, Inc.		Surface req.	
Mark	Before Mark	After Mod.	Modified by	Date	App.	Date			Mat No.	

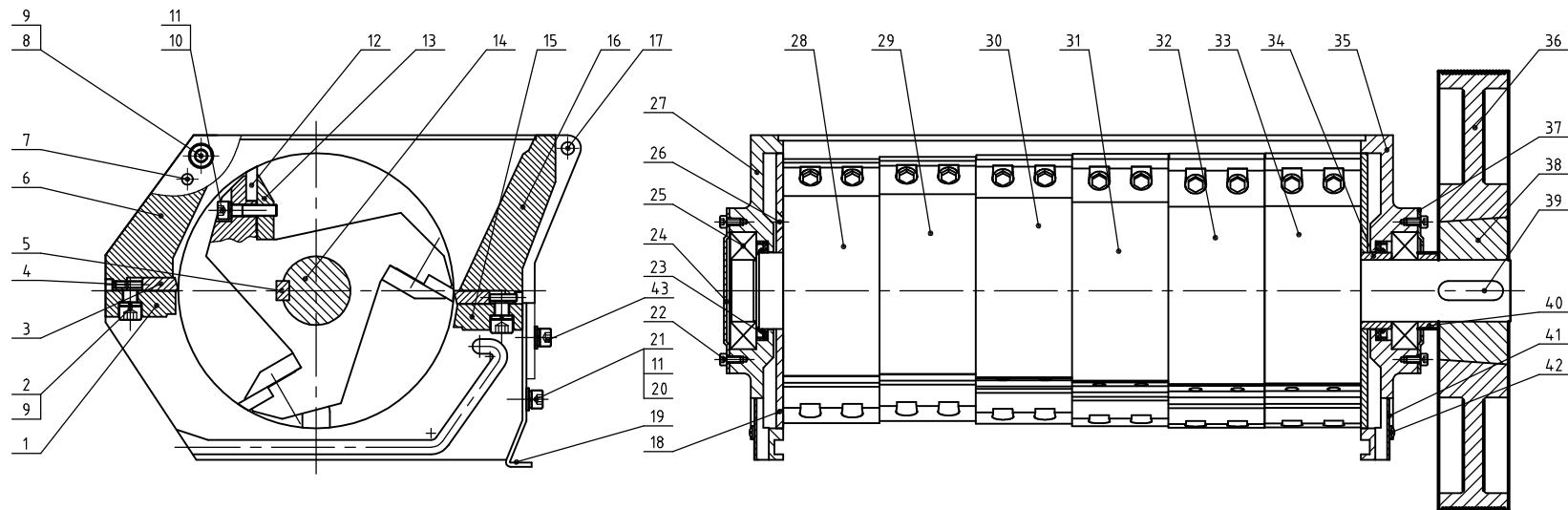

43	YW61082501200	Inner hex column head screw GB/T70.1M6x5-13-Longzine		2							29	BW30002013010	Blade rest 2	QT500-7	1		13	BH10235200010	Blade pressing plate	Q235A	18		
42	YW63050800000	Cross recess pan head screw GB/T40164-Longzine		4							28	BW30002012910	Blade rest 1	QT500-7	1		12	BW41200100010	Rotating blade	SKD11	18		
41	--	Cover plate	SPCC1.5	2							27	BW30204207010	Left end plate	QT500-7	1		11	YW65008000100	Standard spring washer GB/T93.8-Longzine	65Mn	40		
40	BH10204203010	Steel 1	Q235A	1							26	YW61082000100	Inner hex countersink head screw GB/T70.1M6x20-12.9-Longzine		6		10	YW61083500000	Inner hex column head screw GB/T70.1M6x25-12.9-Longzine		36		
39	BH112024.00010	Flat key 14x9x4.6.5	4.5	1							25	YW11620901800	Single line seal deep groove ball bearing 6209-2RS(SKF)		2		9	YW65010000000	Standard spring washer GB/T93.8-Longzine	65Mn	20		
38	BW30002005520	Big taper sleeve SG-38-3020-45-HT250(Canonly)		1							24	BL50204201320	Left bearing ext. cover plate	SPCC2.0	1		8	YW61103500000	Inner hex column head screw GB/T70.1M6x25-12.9-Longzine		12		
37	BL50204201820	Right bearing ext. cover plate	SPCC2.0	1							23	YR80557200000	Oil seal $\phi 72 \times \phi 55 \times 8$		2		7	YW69083500000	Spring column pin GB/T 879.18x35	65Mn	8		
36	BW30001605120	Large bell wheel SG-3020-P200-300HT20(Canonly)	HT200	1							22	YW61051000000	Inner hex column head screw GB/T70.1M6x16-12.9-Longzine		8		6	BW30204213410	Front box block	QT500-7	1		
35	BW30204207110	Right end plate	QT500-7	1							21	YW66081900000	Flat washer 8x19x2.0 Longzine	14.0HV	4		5	BH11204200510	Flat key 14x4.07	4.5	1		
34	BH10204500010	Steel	Q235A	1							20	YW61081600000	Inner hex column head screw GB/T70.1M6x16-12.9-Longzine		2		4	YW68052000000	Inner hex. flat end lock screw GB/T70.1M6x20-12.9-Longzine		4		
33	BW30204213110	Knife rest 6	QT500-7	1							19	--	Storage box hanging plate	SPCC3.0	1		3	YW41204201700	Fixed blade	SKD11	2		
32	BW30204213010	Knife rest 5	QT500-7	1							18	BH1020020010	Fender plate	65Mn	2		2	YW61103000000	Inner hex. column head screw GB/T70.1M6x20-12.9-Longzine		8		
31	BW30204212910	Knife rest 4	QT500-7	1							17	BH10204100010	Rotating shaft	Q235A	2		1	BW30204213510	Front box block pressing block	Q235A	1		
30	BW30002013110	Knife rest 3	QT500-7	1							16	BW30204213610	Rear box block	QT500-7	1		1						
											15	BW30204213710	Rear box block pressing block	Q235A	1								
											14	BH11204210110	Shaft	45	1	No.							

					Draw.	Ver.	Title	Drawing no.	Scale	Num.	Remarks
					Desi.	App.	SG-2042NC				
					Check	by	Cutting Chamber Assembly				
					App.	Date	SHINI 信易電熱機械股份有限公司 Shini Plastics Technologies, Inc.		Surface req.		
Mark	Before Mod.	After Mod.	Modified by	Date	App.	Date			Mat No.		

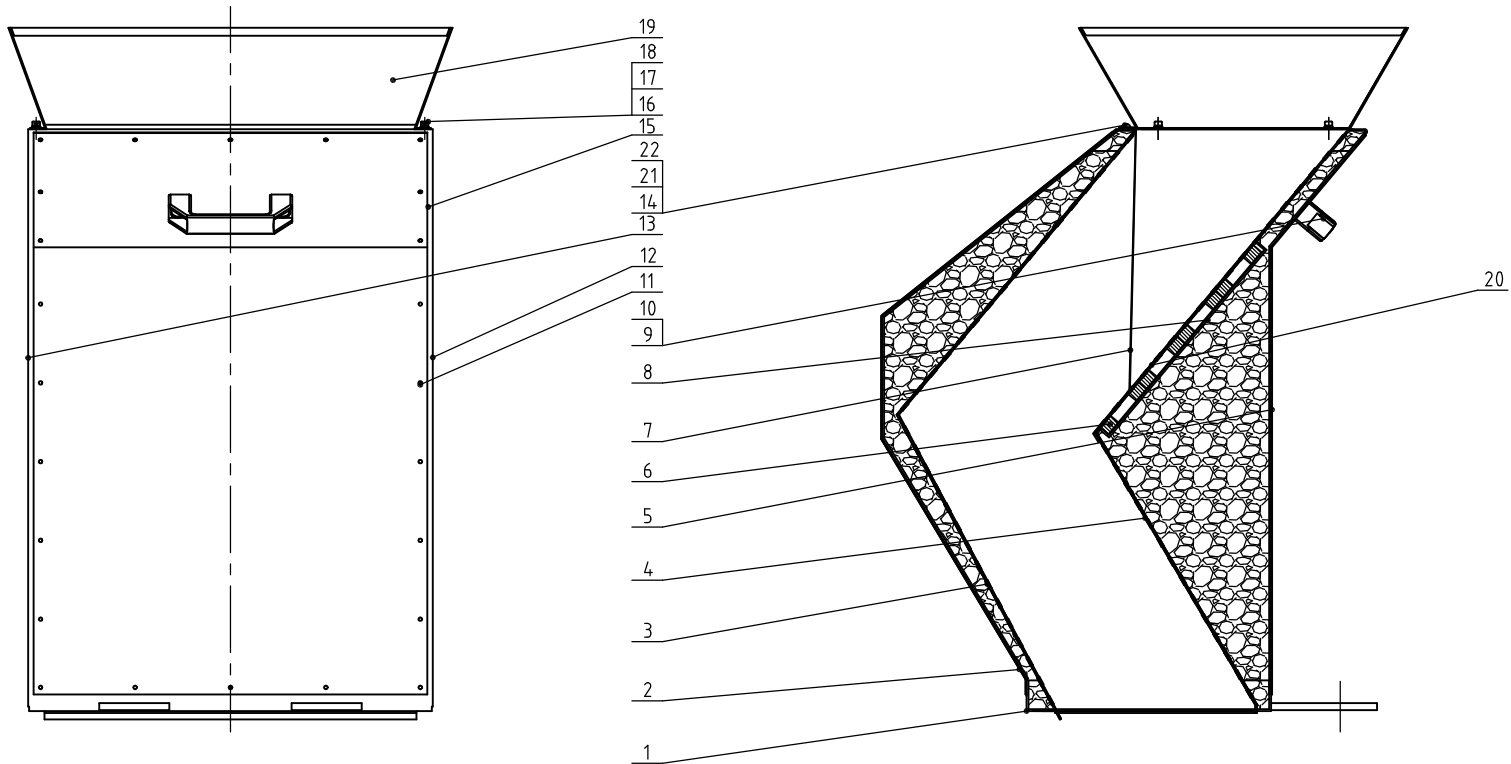

22	YW62051000100	Large recessed flat head screw JIS T111M5x11-Longzine	12.9	3							
21	--	Fender plate pressing plate	SPCC1.5	1		10	YW61081600000	Inner hex. column head screw M6x16	12.9	2	
20	--	Front inner plate 2	SUS201 2.0	1		9	BW20012000140	Handle	Alum. alloy	1	
19	--	Feed part	SPCC1.5	1		8	--	Magnetic box	SPCC1.2	1	
18	YW66051000000	Flat washer 5	140HV	4		7	--	Fender plate	White water-proof cloth	1	
17	YW65005200000	Spring washer 5	65Mn	4		6	YW90683200000	Magnet68x32x12		24	
16	YW61051000000	Inner hex. column head screw M5x10	12.9	4		5	--	Front guard plate	SPCC1.2	1	
15	--	Left & right inner plate	SECC2.0	2		4	--	Front inner plate 1	SECC2.0	1	
14	--	Hopper part	SPCC2.0	1		3	--	Rear inner plate	SECC2.0	1	
13	--	Left guard plate	SPCC1.2	1		2	--	Rear guard plate	SPCC1.2	1	
12	--	Right guard plate	SPCC1.2	1		1	--	Square base	SPCC3.0	1	
11	YW67481900000	Large recessed pan head tapping screw S14.8x10		48		No.	Material number	Name	Mat.	Num.	Remarks

					Draw.		Ver.	Title	SG-2042N(C)	Drawing no.	Scale		Num.	
					Desi.		App. by	Feed Box Assembly				Mat.		
					Check			信易電熱機械股份有限公司 Shini Electric Technologies, Inc.			Surface req.			
Mark	Before Mod.	After Mod.	Modified by	Date	App.	Date						Mat No.		

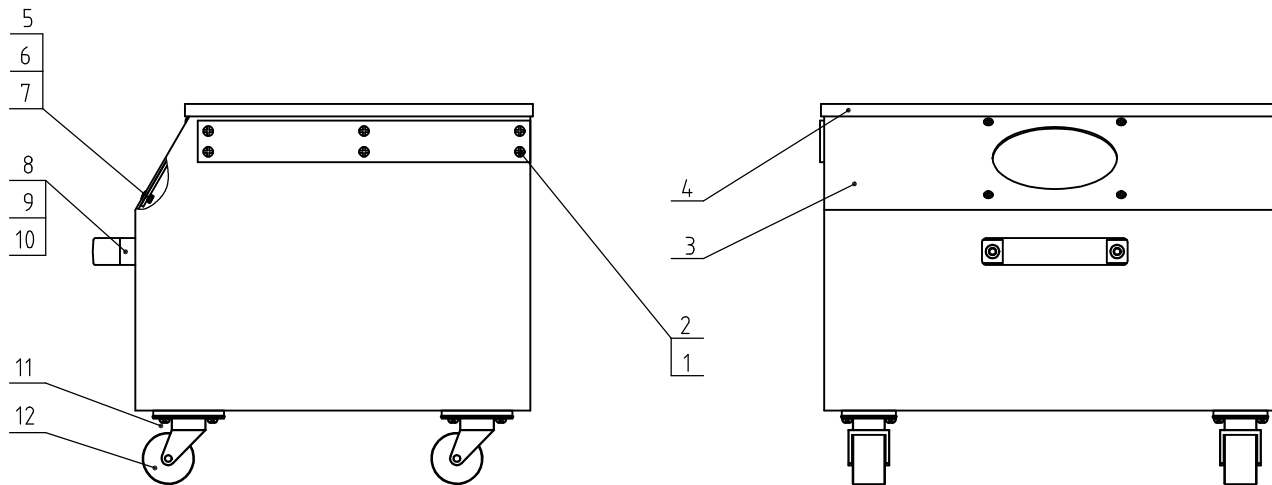

12	YW03000200000	Black castor 2'	Assembly	4	
11	YW62050500000	Large cross recessed flat head screw JS1111 M5x5	Longzine	16	
10	YW64000800100	Anti-loose nut M8		6	2
9	YW61081600000	Inner hex. nut M8x16		8.8	2
8	BW20012000140	Handle	Alum. alloy		1
7	YW64040700100	Anti-loose nut M4		5	4
6	YW62041000000	Large cross flat head screw JS1111 M4x10-Longzine		8.8	4
5	--	Visual window transparent plate	Acrylic		1
4	--	Storage box cover	SECC2.0		1
3	--	Storage case	SECC2.0		1
2	YW61040600000	Inner hex countersunk screw GB/T1703 M4x6-12.9-Longzine		8.8	12
1	BR90202800310	Fender plate	Teflon		2
No.	Material number	Name	Mat.	Num.	Remarks

					Draw.	Ver.	Title	Drawing no.		Num.
					Desi.	App.	SG-2042N(C)			
					Check	by	Storage Box Assembly (option)			Mat.
Mark	Before Mark	After Mod.	Modified by	Date	App.	Date	 信易電熱機械股份有限公司 Shini Plastics Technologies, Inc.			

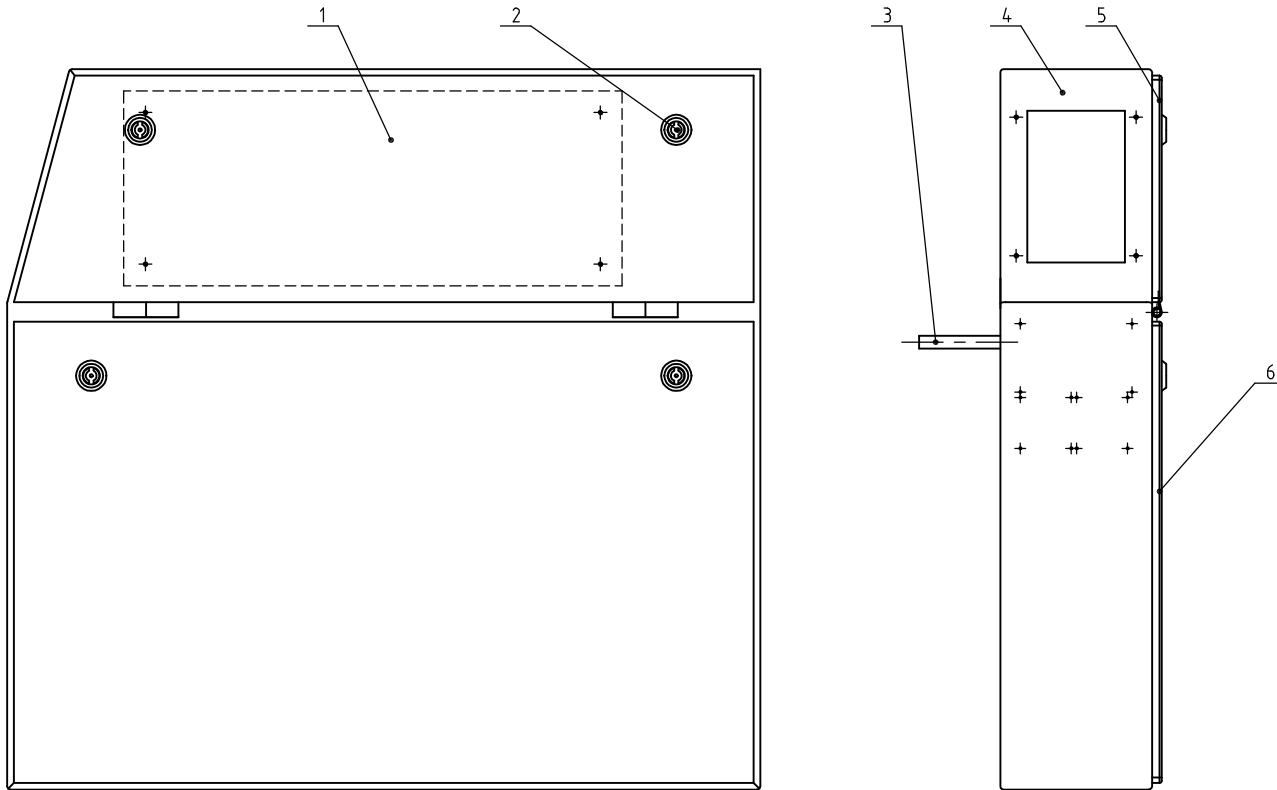

6	--	Shell lower cover plate	SPCC2.0	1	
5	--	Shell upper cover plate	SPCC2.0	1	
4	--	Shell	SPCC3.0	1	
3	--	Feed box support rod	Q235A	1	
2	YW0000000100	Long door lock		4	
1	--	Elec. mount plate	SPCC1.5	1	
No.	Material number	Name	Mat.	Num.	Remarks

					Draw.		Ver.	
					Desi.		App.	
					Check		by	
Mark	Before Mod.	After Mod.	Modified by	Date	App.		Date	

Title SG-2028N(C)/2042N(C)		Drawing no.		Scale	Num.
Control box assembly				 Mat.	
信易電熱機械股份有限公司 Shini Plastics Technologies, Inc.		Surface req.			
				Mat No.	

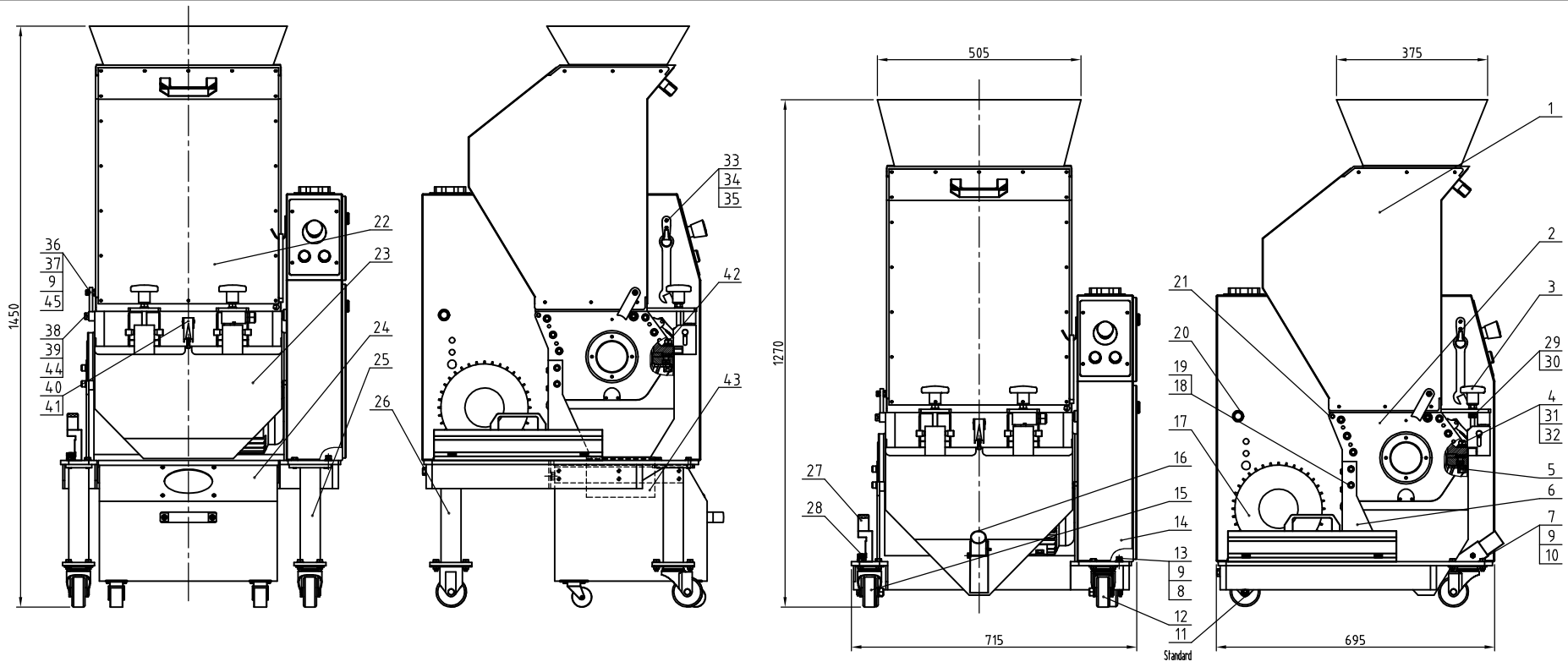

45	YW64080600000	Hex. nut GB/T6170 M8- Longzine	4	1	31	YW65012000000	Standard spring washer GB/T93 12-L-longzine	65Mn	2	15	YW03000300200	Movable castor 3"	Assembly	1		
44	YW66102500000	Flat washer 10x25x15- Longzine	4	2	30	YW68005500000	Escape socket set screw with flat end GB/T17065-Longzine	4.5H	2	14	--	Control box assembly	Assembly	1		
43	BP82204200044	Filter cloth bag	Nylon mesh 400	1	29	BH11241000010	Screw lock screw nut	4	2	13	YW61081600000	Inner hex. cylindrical head screw GB/T91.1M16x-25-Longzine	8.8	4		
42	YW64012100000	Hex. nut GB/T6170 M12- Longzine	4	2	28	YW69621600000	Manual screw M6x20x16	Assembly	2	12	YW03000300000	Brake castor 3"	Assembly	1		
41	YW62041000000	Large cross recessed flat head screw GB/T91.1M12-Longzine	4.8	2	27	BW30204213310	Blade rest shaft	Assembly	1	11	YW03000300300	Fixed castor 3"	Assembly	2		
40	YW02003000400	Snap hook	Assembly	1	26	--	Support foot 1	Q235A&SPH6.0	3	Optional large storage hopper	10	YW64000800100	Non-metal insert hex. lock nut GB/T881.1M8	5	16	
39	YW61102500000	Inner hex column head screw GB/T91.1M12x-25-Longzine	12.9	1	25	--	Support foot 2	Q235A&SPH6.0	1	Optional large storage hopper	9	YW66081900000	Flat washer 8x19x2.0 Longzine	14.0HV	21	
38	BH10162804110	Limit block sleeve	Q235A	1	24	--	Storage box assembly	Assembly	1	Optional large storage hopper	8	YW65008000100	Standard spring washer GB/T93 8-Longzine	65Mn	4	
37	YW61083000000	Inner hex column head screw GB/T91.1M8x-25-Longzine	12.9	1	23	--	Storage hopper assembly	Assembly	1	Optional large storage hopper	7	YW60082500300	Hex. bolt GB/T5783 M8x25-12.9-Longzine	4.8	16	
36	--	Limit block	SPH8.0	1	22	--	Feed box assembly	Assembly	1	Optional large storage hopper	6	--	Rack assembly	Assembly	1	
35	JT10001806000	Short click pulley wrench 18	Q235A	1	21	YW61062000200	Inner hex cylindrical head screw GB/T91.1M12x-25-Longzine	12.9	4	5	--	Screen bracket assembly	Assembly	1		
34	YW62041000000	Large cross recessed flat head screw GB/T91.1M12-Longzine	4.8	2	20	YR40162800000	Rubber sleeve	PP	1	4	YW60128000000	Hex. bolt GB/T5782 M12x48-8.8-Longzine	8.8	2		
33	YW90351800100	Small Head Flat Head Hex Head Screws 4x 5mm hole 40mm-50mm		1	19	YW65010000000	Standard spring washer GB/T93 10-Longzine	65Mn	7	3	BH10204208510	Feed box star assembly	Assembly	2		
32	YW66122400000	Flat washer GB/T9171 12- Longzine	SUS304	2	18	YW61102000000	Inner hex. cylindrical head screw GB/T91.1M12x-25-Longzine	12.9	4	2	--	Cutting chamber assembly	Assembly	1		
					17	--	Gearing device	Assembly	1	1	--	Feed box assembly	Assembly	1		
					16	--	Storage hopper assembly	Assembly	1	Standard	No.	Code	Name	Mat.	Qty.	Remark

制图	版号	标题	SG-2042N	图号		比例	数量
设计	核准	粉碎机总成				表面要求	物料号
校对	核准	SHINI 信易电热机械股份有限公司 Shini Plastics Technologies, Inc.					
标记	更改前	更改后	更改人	日期	审核	日期	

Standard weight (kg)	Noise during granulating dB(A)	Max. cutting ability (kg/hr)	Cutting chamber size (mm)	Rotating Blade Qty.	Fixed Blade Qty.	Cutter Blade	Max. shaft rotation (r.p.m)	Motor power (KW)	(Ver. No.)
300(315)	85-90	135	200×420	3	2	SKD11	290	3.0(4.0)	Ver.F

Additional drawing

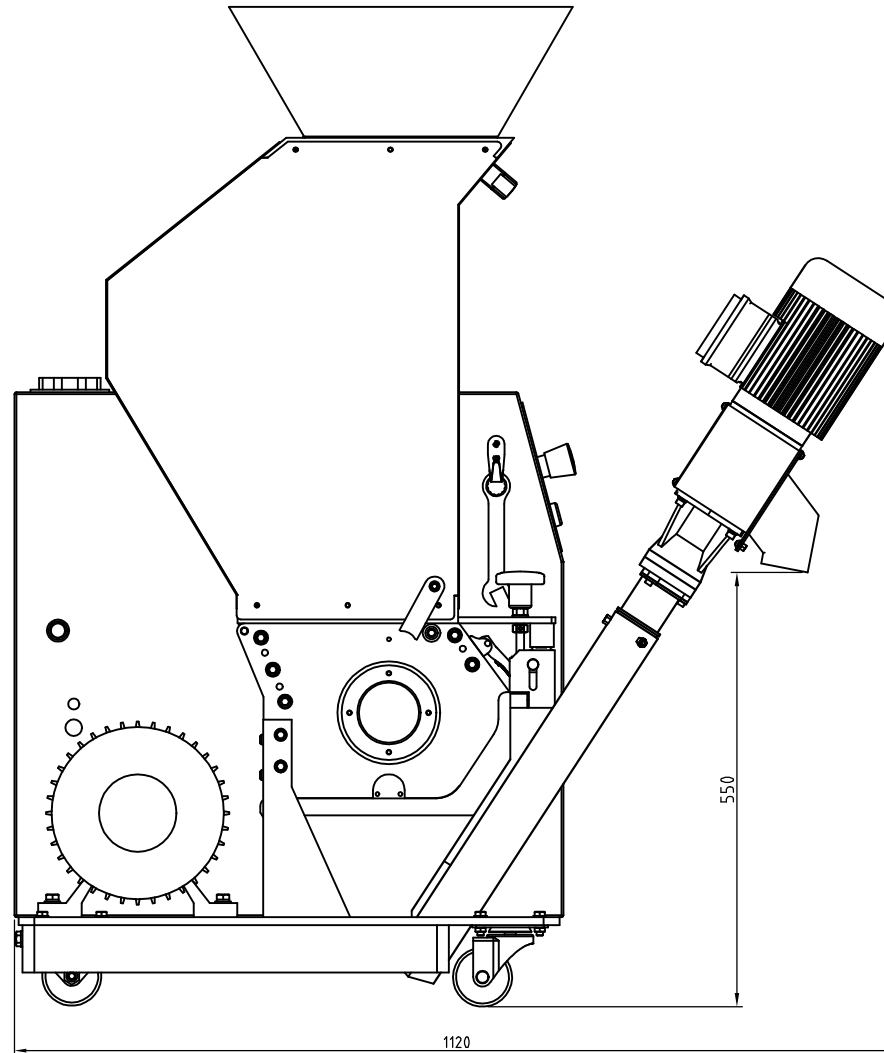

Optional spring conveyor

- Notes: 1) The max. cutting capacity depends on the material size and crushed material;
 2) The noise when granulating is different due to the configuration of crushed materials and motor.
 3) SKD11 Japan JIS standard;
 4) To avoid material sticking the blade, all materials to be crushed shall be crushed at normal temp.;
 5) Machine power: 3 ϕ 400VAC, 50Hz;
 6) The values in the brackets are for the optional large motor power model of SG-2042NH.

制图	版号	标题	图号	比例	数量
设计	核准	SG-2042N 粉碎机总成		1:1	1
校对	核准	 信易電熱機械股份有限公司 Shini Plastics Technologies, Inc.		表面要求	
审核	日期			物料号	
标记	更改前	更改后	更改人	日期	

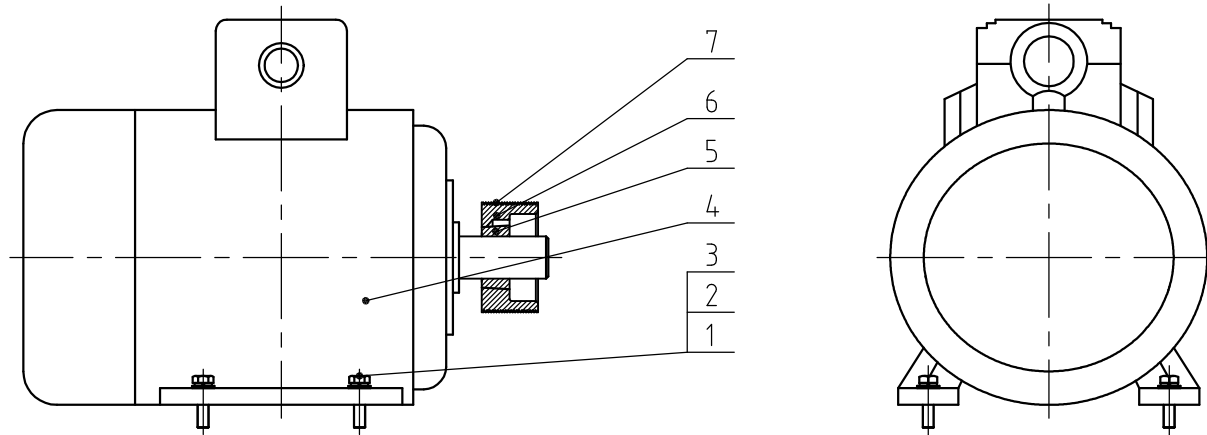

7	YW30205400000	Poly V-belt 20 PJ 54"		1	
6	BW30002005220	Small belt pulley SG-20-P20P 80/3-160 HT250 (assembly)		1	
5	BW30002005420	Small taper sleeve SG-20-1610-28 HT250 (assembly)		1	
4	YM10203000600	Motor W20 3kW-132S-6P B3R IE3 230/400/460V		1	
3	YW66102500000	Flat washer 10x25x1.5-Longzine	14.0HV	4	
2	YW65010000000	Standard spring washer GB/T93 10-Longzine	65Mn	4	
1	YW60104000100	Hex bolt GB/T5783 M10x40-8.8-Longzine		4	
No.	Material number	Name	Mat.	Num.	Remarks

					Draw.		Ver.		Title	SG-2042N(C)	Drawing no.	Scale		Num.	
					Desi.		App.		Actuating Device				Mat.		
					Check		by		信易電熱機械股份有限公司 Shini Plastics Technologies, Inc.				Surface req.		
Mark	Before Mark	After Mod.	Modified by	Date	App.		Date								Mat No.

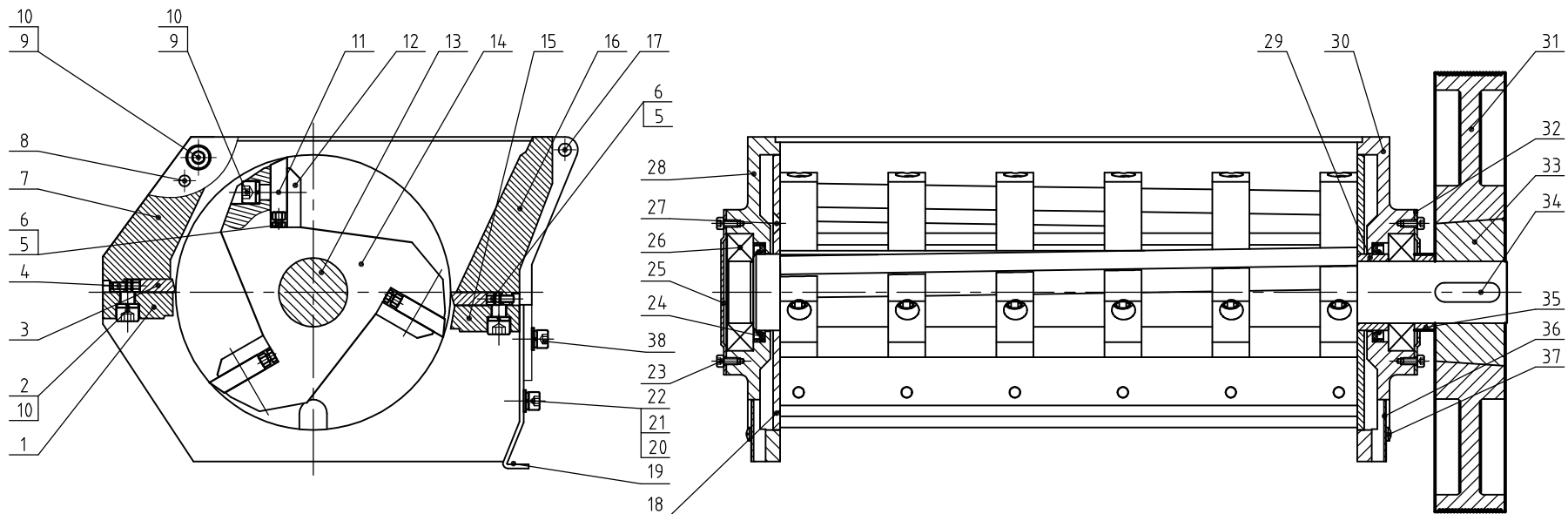

38	YW61082501200	Inner hex. column head screw GB/T7111M5x11-12.9-Longzine		2		27	YW61081200100	Inner hex. countersink head screw GB/T7031M4x12-12.9-Longzine		6		12	BH11204240410	Blade pressing plate	Q235A	3	
37	YW63050800000	Cross recessed pan head screw GB/T14954-Longzine		4		26	YW11620901800	Bearing 6209-2RS1		2	SKF	11	YW42160040000	Rotating blade	S45C&V-4E	3	
36	--	One plate	SPCC15	2		25	BL50204201320	Left bearing ext. cover plate	SPCC2.0	1		10	YW65010000000	Standard spring washer GB/T9310-Longzine		38	
35	BH10204203010	Steel	Q235A	1		24	YR80557200000	oil seal φ72xφ55x8		2		9	YW61103500000	Inner hex. column head screw GB/T7111M5x11-12.9-Longzine		38	
34	BH1120400010	Flat key 14x9x6.5	45	1		23	YW61051000000	Inner hex. column head screw GB/T7111M5x11-12.9-Longzine		8		8	YW69083500000	Spring column pin GB/T 879.18x35	65Mn	8	
33	BW30002005520	Big taper sleeve S6-28-3029-45 H125H (assembly)		1		22	YW66081900000	Flat washer A grade GB/T97.1.8		4		7	BW30204204540	Front box block	QT500-7	1	
32	BL50204201820	Right bearing ext. cover plate	SPCC2.0	1		21	YW65008000100	Standard spring washer GB/T9310-Longzine		4		6	YW64050800100	Hex. nut GB/T6170 M5-A2-70(SUS)		10	
31	BW30001605120	Large ball wheel S6-28-3029-30 H125H (assembly)		1		20	YW61081600000	Inner hex. column head screw GB/T7111M5x11-12.9-Longzine		2		5	YW60512880000	Hex. bolt GB/T5783 M5x12-8.8-Longzine		10	
30	BW30204207110	Right end plate	QT500-7	1		19	--	Storage box hanging plate	SPCC3.0	1		4	YW68051600000	Inner hex. flat end lock screw GB/T7111M5x11-Longzine		4	
29	BH10204500010	Skere	Q235A	1		18	BH11020020010	Fender plate	SK5	2		3	YW40204220000	Fixed blade	S45C&V-4E	2	
28	BW30204207010	Left end plate	QT500-7	1		17	BH10204100010	Rotating shaft	Q235A	2		2	YW61103000000	Inner hex. column head screw GB/T7111M5x11-12.9-Longzine		8	
						16	BW30204204640	Rear box block	Q235A	1		1	BW30204213510	Front box block pressing block	Q235A	1	
						15	BW30204213710	Rear box block pressing block	Q235A	1		1	BW30204213510	Front box block pressing block	Q235A	1	
						14	--	Blade rest	45	6		No.	Material number	Name	Mat.	Num.	Remarks
						13	BH11204260010	Blade rest shaft	45	1		Title SG-2042N		Drawing no.		Scale	Num.
								Draw.		Ver.	Cutting Chamber Assembly					Mat.	
								Desi.		App. by	SHINI 信易電熱機械股份有限公司 Shini Plastics Technologies, Inc.					Surface req.	
								Check		Date					Mat No.		
								App.		Date							

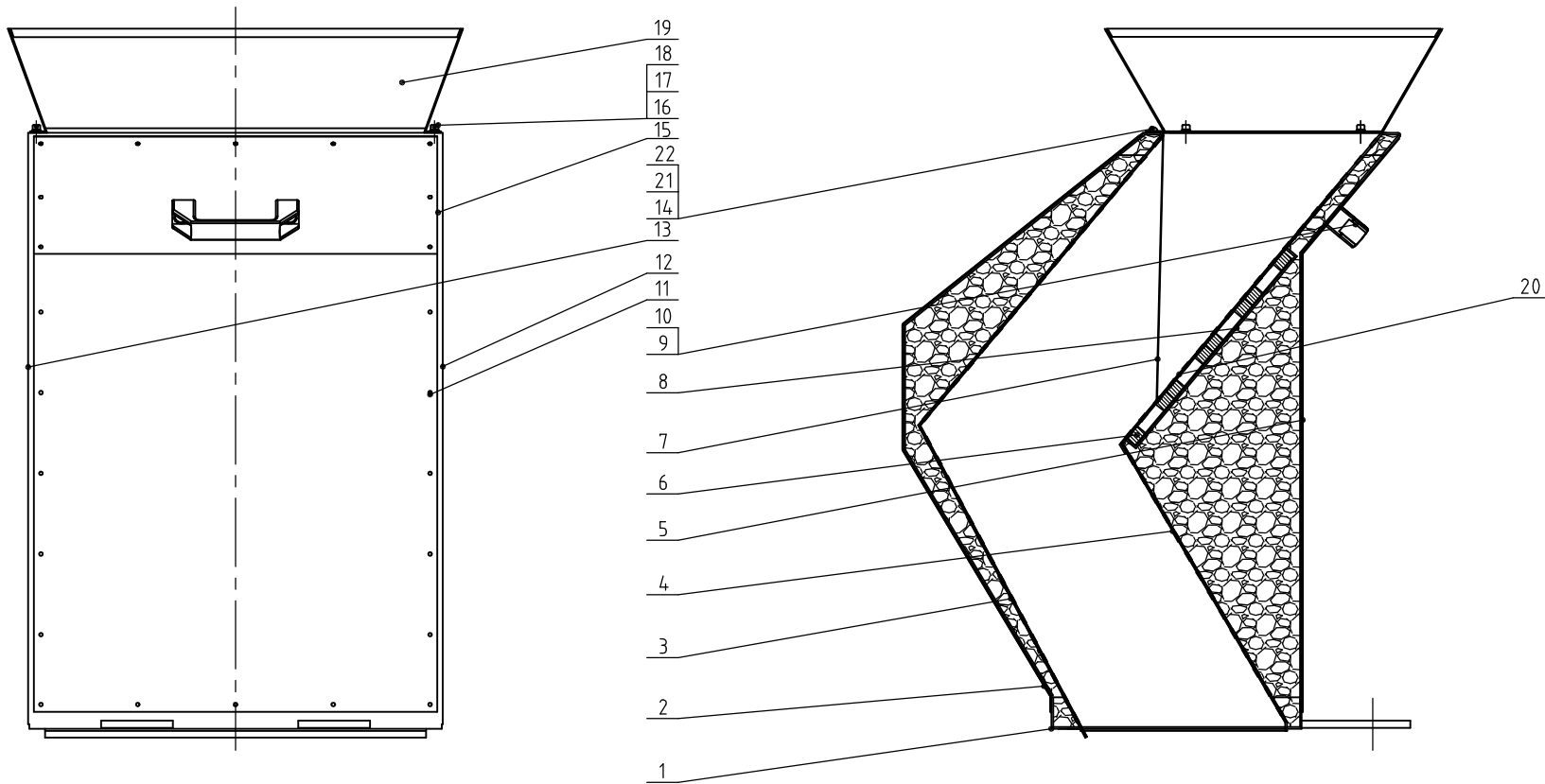

22	YW62051000100	Large recessed flat head screw JS 1111M6-11-Longline	12.9	3							
21	--	Fender plate pressing plate	SPCC1.5	1		10	YW61081600000	Inner hex. column head screw M6x16	12.9	2	
20	--	Front inner plate 2	SUS201 2.0	1		9	BW20012000140	Handle	Alum. alloy	1	
19	--	Feed part	SPCC1.5	1		8	--	Magnetic box	SPCC1.2	1	
18	YW66051000000	Flat washer 5	140HV	4		7	--	Fender plate	White water-proof cloth	1	
17	YW65005200000	Spring washer 5	65Mn	4		6	YW90683200000	Magnet 68x32x12		24	
16	YW61051000000	Inner hex. column head screw M5x11	12.9	4		5	--	Front guard plate	SPCC1.2	1	
15	--	Left & right inner plate	SECC2.0	2		4	--	Front inner plate 1	SECC2.0	1	
14	--	Hopper part	SPCC2.0	1		3	--	Rear inner plate	SECC2.0	1	
13	--	Left guard plate	SPCC1.2	1		2	--	Rear guard plate	SPCC1.2	1	
12	--	Right guard plate	SPCC1.2	1		1	--	Square base	SPCC3.0	1	
11	YW67481900000	Large recessed pan head tapping screw S14.8x19		48		No.	Material number	Name	Mat.	Num.	Remarks

					Draw.	Ver.	Title SG-2042N(C)		Drawing no.		Scale	Num.
					Desi.	App.	Feed Box Assembly					Mat.
					Check	by					Surface req.	
Mark	Before Mod.	After Mod.	Modified by.	Date	App.	Date	SHINI 信易電熱機械股份有限公司 Shini Plastics Technology, Inc.				Mat No.	

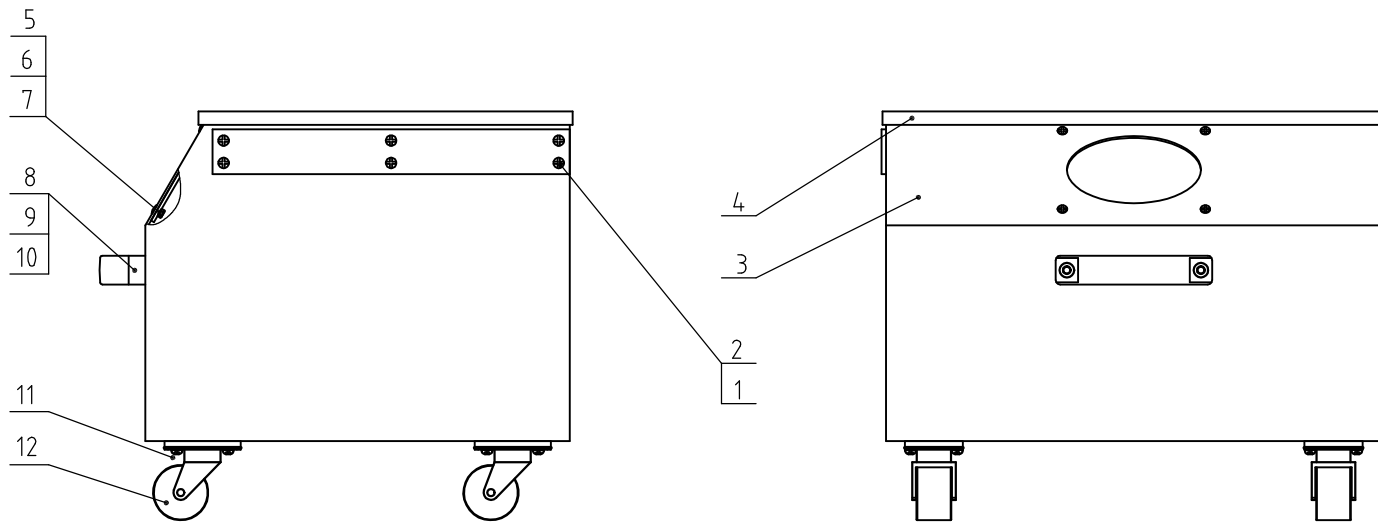

12	YW03000200000	Black castor 2"	Assembly	4	
11	YW62050500000	Large cross recessed flat head screw JS1111 M5x5	Longzine	16	
10	YW64000800100	Anti-loose nut M8	6	2	
9	YW61081600000	Inner hex. nut M8x16	8.8	2	
8	BW20012000140	Handle	Alum. alloy	1	
7	YW64040700100	Anti-loose nut M4	5	4	
6	YW62041000000	Large cross flat head screw JS1111 M4x10-Longzine	8.8	4	
5	--	Visual window transparent plate	Acrylic	1	
4	--	Storage box cover	SECC2.0	1	
3	--	Storage case	SECC2.0	1	
2	YW61040600000	Inner hex countersunk screw GB/T70.3 M4x6-12.9-Longzine	8.8	12	
1	BR90202800310	Fender plate	Teflon	2	borrowed
No.	Material number	Name	Mat.	Num.	Remarks

					Draw.		Ver.		Title	SG-2042N(C)	Drawing no.		Num.		
					Desi.		App.		Storage Box Assembly (option)				Mat.		
					Check		by		 信易電熱機械股份有限公司 Shini Plastics Technologies, Inc.						
Mark	Before Mark	After Mod.	Modified by	Date	App.		Date								

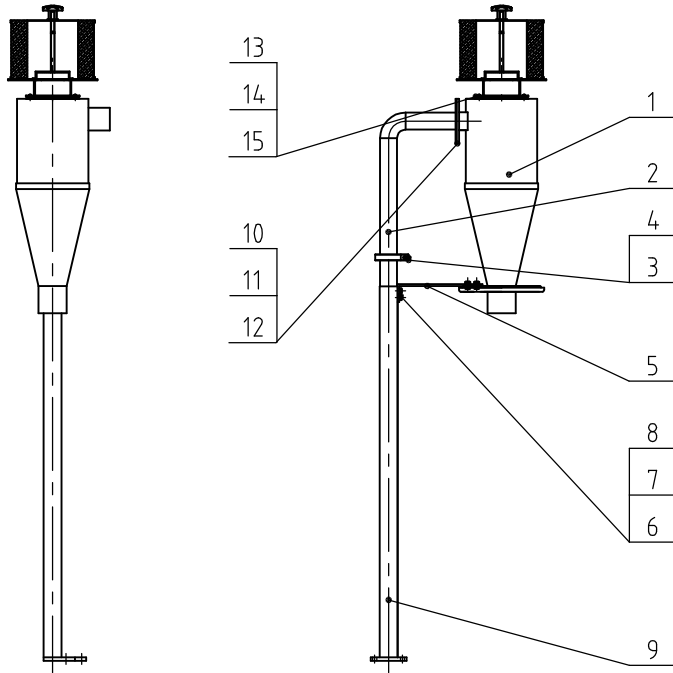

15	YW60512880000	Inner hex. bolt GB/T5783 M5x12-8.8-Longzine		4	
14	S00000000357	Simple filter	Assembly	1	
13	BL59160000121	Filter	Welding assembly	1	
12	YW65008000100	Standard spring washer GB/T93 8-Longzine		4	
11	YW66081900000	Flat washer 8x19x2.0 Longzine		4	
10	YW60081600100	Inner hex. bolt GB/T5781 M8x6-4.8-Longzine		4	
9	--	Lower support	Welding assembly	1	
8	YW65005200000	Standard spring washer GB/T93 5-Longzine	60Mn	2	
7	YW66051000000	Flat washer A grade GB/T97.15-Longzine	140HV	6	
6	YW61050600300	Inner hex. column head screw GB/T70.1 M6x6-12.9-Longzine		4	
5	--	Support plate	SPH4	1	
4	YR20001500000	Food connector seal ring 1.5"		1	
3	YW07001500500	1.5" food connector pipe clamp		1	
2	S000000000620	Upper support	Welding assembly	1	
1	S000000000966	Cycloner	Welding assembly	1	
No.	Material number	Name	Mat.	Num	Remarks

					Draw.		Ver.		Title	SG-16N/20N	Drawing no.		Num.
					Desi.		App		BC Cyclone Support Rack (option)				Mat.
					Check		by		信易電熱機械股份有限公司 Shini Plastics Technologies, Inc.				
Mark	Before Mark	After Mod.	Modified by	Date	App.		Date						

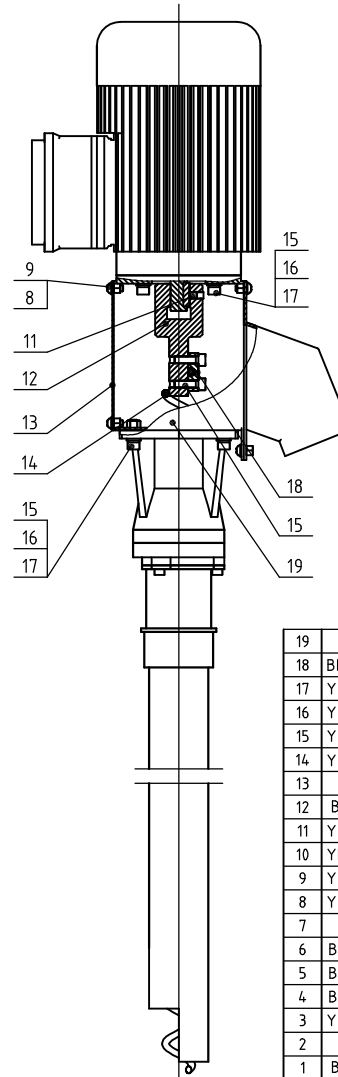
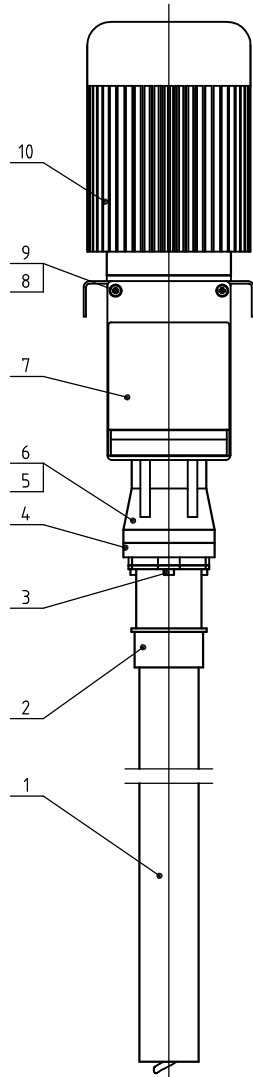

No.	Material number	Name	Mat.	Num.	Remarks
19	--	Transfer box	Welding assembly	1	
18	BH10503600010	Pressing block	SPH10.0	1	
17	YW66061300000	Flat washer 6	140HV	10	
16	YW65060000100	Spring washer 6	65Mn	10	
15	YW61062000300	Inner hex column head screw M6×20	12.9	10	
14	YW01162800600	Conveying spring	SWP-B	1	
13	--	Cover plate	SUS201 1.5	1	
12	BH10162800440	Connecting shaft	Q235A	1	
11	YW68006600000	Inner hex flat end lock screw M6×6	12.9	2	
10	YM50761400000	Motor 0.18kW	Assembly	1	
9	YW66051000000	Flat washer 5	140HV	8	
8	YW62051000100	Cross recessed pan head screw M5×10	4.8	8	
7	--	Material outlet	SUS201 2.0	1	
6	BP20500300050	Pipe sleeve seal ring	Rubber	1	
5	BW20500000010	Pipe sleeve base	YL112	1	
4	BW20500000110	Pipe sleeve cover	YL112	1	
3	YW60054000000	Inner hex screw M5×4.0	8.8	3	
2	--	Conveying pipe sleeve	Welding assembly	1	
1	BR90162800110	Conveying pipe	PA12	1	

Mark	Before Mod.	After Mod.	Modified by.	Date	App.	Draw	Ver.

Title SG-16N/20N		Drawing no.		Scale	Num.
Rotary Spring Conveyor (option)					Mat.
				Surface req.	
				Mat No.	



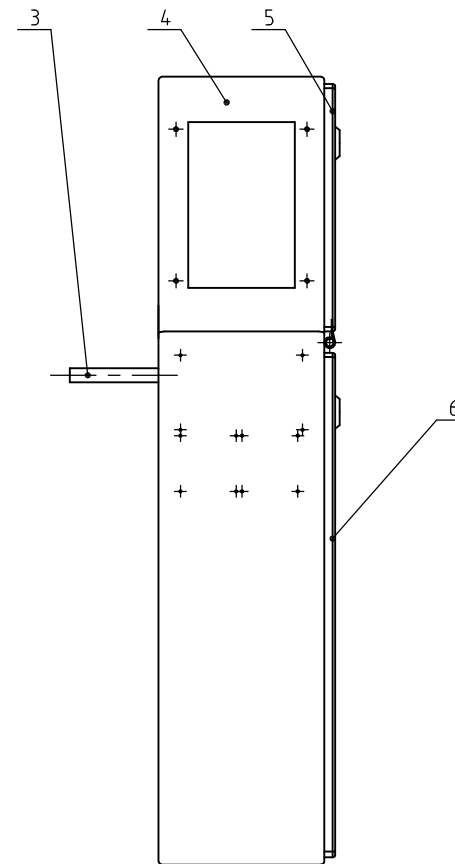
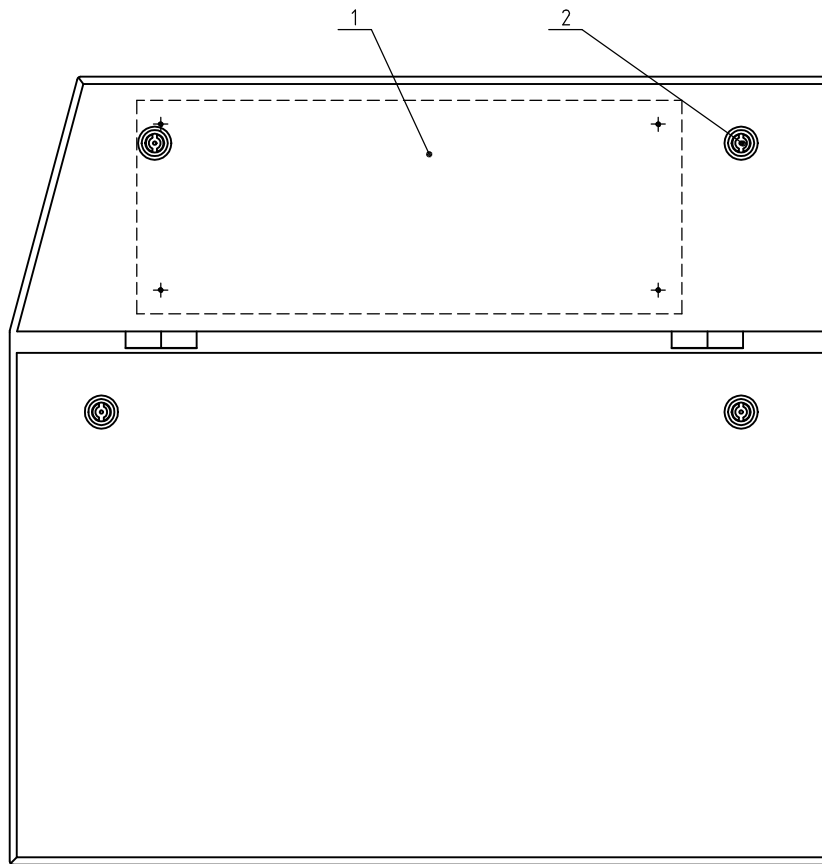

6	--	Shell lower cover plate	SPCC2.0	1	
5	--	Shell upper cover plate	SPCC2.0	1	
4	--	Shell	SPCC3.0	1	
3	--	Feed box support rod	Q235A	1	
2	YW0000000100	Long door lock		4	
1	--	Elec. mount plate	SPCC1.5	1	
No.	Material number	Name	Mat.	Num.	Remarks

					Draw.	Ver.	
					Desi.	App.	
					Check	by	
Mark	Before Mod.	After Mod.	Modified by.	Date	App.	Date	

Title: SG-2028N(C)/2042N(C)		Drawing no.		Scale	Num.
Control box assembly					Mat.
信易電熱機械股份有限公司 Shini Plastics Technologies, Inc.				Surface req.	
				Mat No.	