

CD Series

Cabinet Dryer

Date: Apr, 2016

Version: Ver.B (English)



Contents

| | |
|---|-----------|
| 1. General Description | 7 |
| 1.1 Coding Principle | 8 |
| 1.2 Feature..... | 8 |
| 1.3 Technical Specifications..... | 10 |
| 1.3.1 Specifications | 10 |
| 1.3.2 Outline Drawing | 11 |
| 1.4 Safety Regulations | 12 |
| 1.4.1 Safety Signs and Labels..... | 12 |
| 1.4.2 Transportation and Storage of the Machine..... | 12 |
| 1.5 Exemption Clause | 13 |
| 2. Structure Characteristics and Working Principle | 15 |
| 2.1 Main Functions..... | 15 |
| 2.2 Working Principle Illustration | 15 |
| 2.3 Drawing and Parts List | 16 |
| 2.3.1 Assembly Drawing | 16 |
| 2.3.2 Parts List..... | 17 |
| 2.4 Electrical Diagram | 20 |
| 2.4.1 Main Circuit (400V) | 20 |
| 2.4.2 Control Circuit (400V) | 21 |
| 2.4.3 Components Layout (400V)..... | 22 |
| 2.4.4 Electrical Components List (400V) | 23 |
| 2.4.5 Main Circuit (230V) | 27 |
| 2.4.6 Control Circuit (230V) | 28 |
| 2.4.7 Components Layout (230V)..... | 29 |
| 2.4.8 Electrical Components List (230V) | 30 |
| 2.4.9 Main Electrical Components Description | 34 |
| 3. Installation and Debugging..... | 35 |
| 3.1 Attentions During Installation | 35 |
| 3.2 Machine Ins Tallation Distance | 35 |

| | | |
|-----------|---|-----------|
| 3.3 | Check the Rotation Direction of Blower..... | 36 |
| 4. | Application and Operation..... | 37 |
| 4.1 | Test..... | 37 |
| 4.2 | Setting Temperature | 37 |
| 4.2.1 | Keys Operature Instruction | 38 |
| 4.3 | Adjustment of Air Rate | 39 |
| 4.4 | Start-up Timer Setting | 39 |
| 4.5 | Setting the Over-thermal Protector..... | 40 |
| 5. | Trouble-shooting | 41 |
| 6. | Maintenance and Repair | 42 |
| 6.1 | Maintenance Schedule..... | 43 |
| 6.1.1 | About the Machine..... | 43 |
| 6.1.2 | Electrical Installation..... | 43 |
| 6.1.3 | Daily Checking..... | 43 |
| 6.1.4 | Weekly Checking..... | 43 |
| 6.1.5 | Monthly Checking | 43 |

Table Index

| | | |
|------------|---|----|
| Table 2-1: | Parts List..... | 17 |
| Table 2-2: | Electrical Components List (CD-5/CD-5-HT) (400V)..... | 23 |
| Table 2-3: | Electrical Components List (CD-9/CD-9-HT) (400V)..... | 24 |
| Table 2-4: | Electrical Components List (CD-20/CD-20-HT) (400V)..... | 25 |
| Table 2-5: | Electrical Components List (CD-20L/CD-20L-HT) (400V)..... | 26 |
| Table 2-6: | Electrical Components List (CD-5) (230V) | 30 |
| Table 2-7: | Electrical Components List (CD-9) (230V) | 31 |
| Table 2-8: | Electrical Components List (CD-20) (230V) | 32 |
| Table 2-9: | Electrical Components List (CD-20L)(230V) | 33 |

Picture Index

| | |
|---|----|
| Picture 1-1: Outline Drawing | 11 |
| Picture 2-1: Working Principle Illustration..... | 15 |
| Picture 2-2: Assembly Drawing | 16 |
| Picture 2-3: Main Circuit (400V) | 20 |
| Picture 2-4: Control Circuit (400V) | 21 |
| Picture 2-5: Components Layout (400V)..... | 22 |
| Picture 2-6: Main Circuit (230V) | 27 |
| Picture 2-7: Control Circuit (230V) | 28 |
| Picture 2-8: Components Layout (230V)..... | 29 |
| Picture 2-9: Overload Relay | 34 |
| Picture 3-1: Machine Ins Tallation Distance | 35 |
| Picture 3-2: Blower Inlet / Outlet | 36 |
| Picture 4-1: Temp. Controller | 37 |
| Picture 4-2: Adjustment of Air Rate..... | 39 |
| Picture 4-3: Start-up Timer Setting..... | 40 |
| Picture 4-4: Setting the Over-thermal Protector | 40 |

1. General Description



Read this manual carefully before operation to prevent damage of the machine or personal injuries.



Forbidden to process flammable or toxic material!

CD series of cabinet dryer are mostly used for simultaneous drying of different kinds of polymers in small quantities or for drying materials for trial moulding. They can also be applied in electronic engineering, electroplating, pharmacy, paint baking, printing industries, etc. for preheating or drying related products.



Model: CD-9



Model: CD-20-HT

1.1 Coding Principle

CD- x x - x x

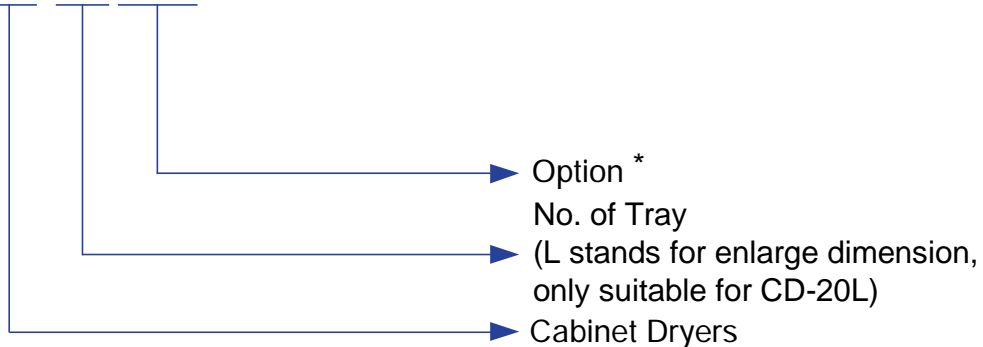

Note: *

CE=CE Conformity

1.2 Feature

1) Standard configuration

- Accurate P.I.D. temperature control to achieve an even drying effect.
- Air-proofed insulative door can maintain temperature constantly inside to reduce energy consumption.
- Stainless steel tray and liner bring no contamination to materials.
- Unique design of adjustable air inlet and exhaust.
- 24 hours timer, easy to operate.
- Overheat protector can prevent excessive drying.
- Motor overload relay.
- Visible alarm to indicate troubles immediately
- Power would be automatically cut off when drying temperature exceeds set deviation value to protect thermal fuse.

2) Accessory option

- Air exhausting device should be opted for when handling with the volatile material.
- Flanges of air inlet and outlet are optional.
- The whole unit and tray can be customized based on demands.

All service work should be carried out by a person with technical training or corresponding professional experience. The manual contains instructions for both handling and servicing. Chapter 6, which contains service instructions intended for service engineers. Other chapters contain instructions for the daily operator.

Any modifications of the machine must be approved by SHINI in order to avoid personal injury and damage to machine. We shall not be liable for any damage caused by unauthorized change of the machine.

Our company provides excellent after-sales service. Should you have any problem during using the machine, please contact the company or the local vendor.

Headquarter and Taipei factory:

Tel: (886) 2 2680 9119

Shini Plastics Technologies (Dongguan), Inc:

Tel: (86) 769 8111 6600

Shini Plastics Technologies India Pvt.Ltd. :

Tel: (91) 250 3021 166

1.3 Technical Specifications

1.3.1 Specifications

Table 1-1: Specifications

| Model | Ver. | Pipe Heater (kW) | Blower Power (kW, 50/60 Hz) | Temperature Range (°C) | Number Of Trays | Total Tray Capacity (kg) | Outer Dimensions H×W×D (mm) | Inner Dimensions H1×W1×D1 (mm) | Weight (kg) |
|------------------------|------|------------------|-----------------------------|------------------------|-----------------|--------------------------|-----------------------------|--------------------------------|-------------|
| CD-5(60Hz) | A | 4 | 0.55 | 200 | 5 | 50 | 1200×800×610 | 660×600×550 | 150 |
| CD-5-HT(60Hz) | A | | | 250 | | | 1380×860×731 | | 200 |
| CD-9(60Hz) | A | 4.5 | 0.55 | 200 | 9 | 90 | 1440×800×610 | 900×600×550 | 180 |
| CD-9-HT (50Hz/60Hz) | A | | | 250 | | | 1640×920×731 | | 252 |
| CD-20 | B | 9 | 1.5 | 200 | 20 | 200 | 1700×1210×860 | 1000×990×800 | 415 |
| CD-20-HT | B | | | 250 | | | 1887×1310×1032 | | 587 |
| CD-20L | B | 18 | 1.5 | 200 | 20 | 350 | 1865×1800×1060 | 1200×1600×1000 | 550 |
| CD-20L-HT | B | | | 250 | | | 2052×1900×1232 | | 778 |

Note: 1) Power supply: 3Φ, 230 / 400 / 460 / 575VAC, 50 / 60Hz.

2) "HT" stands for heat insulation model, the surface temperature of which will not be more than 80°C when setup temperature is 250°C.

3) When drying temperature is below 150 °C, "HT" models can keep internal temperature accuracy of ±5 °C, when it is above 150 °C, internal temperature accuracy is ±12 °C.

We reserve the right to change specifications without prior notice.

1.3.2 Outline Drawing

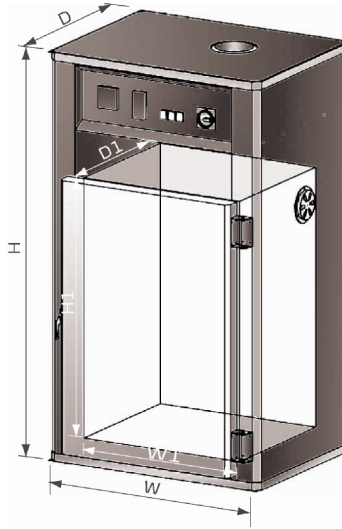

Picture 1-1: Outline Drawing

1.4 Safety Regulations

1.4.1 Safety Signs and Labels

Please abide by the safety guide when you operate the machine so as to prevent damage of the machine and personal injuries.



All electrical components should be installed by qualified electricians.
Turn off main switch and control switch during repair and maintenance.



Warning! High voltage!
This mark is attached on the cover of the control box.



Warning! Be careful!
Be more careful when this mark appears.



Attention!
No need for regular inspection because all the electrical parts in the control unit are fixed tightly!

1.4.2 Transportation and Storage of the Machine

Transportation and storage of the machine

- 1) CD series are packed in crates or plywood cases with wooden pallet at the bottom, suitable for quick positioning by fork lift.
- 2) After unpacked, castors equipped on the machine can be used for ease of movement.
- 3) Do not rotate the machine and avoid collision with other objects during transportation to prevent improper functioning.
- 4) The structure of the machine is well-balanced, although it should also be handled with care when lifting the machine for fear of falling down.
- 5) The machine and its attached parts can be kept at a temperature from -25°C to $+55^{\circ}\text{C}$ for long distance transportation and for a short distance, it can be transported with temperature under $+70^{\circ}\text{C}$.

Storage

- 1) CD series should be stored indoors with temperature kept from 5°C to 40°C and humidity below 80%.
- 2) Disconnect all power supply and turn off main switch and control switch.
- 3) Keep the whole machine, especially the electrical components away from water to avoid potential troubles caused by the water.
- 4) Plastic film should be used to protect the machine from dust and rains.

Working environment

- 1) Indoors in a dry environment with max. temperature +45°C and humidity no more than 80%.

Do not use the machine:

- 1) If it is with a damaged cord.
- 2) On a wet floor or when it is exposed to rain to avoid electrical shock.
- 3) If it has been dropped or damaged until it is checked or fixed by a qualified serviceman.
- 4) This equipment works normally in the environment with altitude within 3000m.
- 5) At least a clearance of 1m surrounding the equipment is required during operation. Keep this equipment away from flammable sources at least two meters.
- 6) Avoid vibration, magnetic disturbance at the operation area.

Rejected parts disposal

When the equipment has run out its life time and can not be used any more, unplug the power supply and dispose of it properly according to local code.

Fire hazard



In case of fire, CO₂ dry powder fire extinguisher should be applied.

1.5 Exemption Clause

The following statements clarify the responsibilities and regulations born by any buyer or user who purchases products and accessories from Shini (including employees and agents).

Shini is exempted from liability for any costs, fees, claims and losses caused by reasons below:

1. Any careless or man-made installations, operation and maintenances upon machines without referring to the Manual prior to machine using.
2. Any incidents beyond human reasonable controls, which include man-made vicious or deliberate damages or abnormal power, and machine faults caused by irresistible natural disasters including fire, flood, storm and earthquake.
3. Any operational actions that are not authorized by Shini upon machine, including adding or replacing accessories, dismantling, delivering or repairing.
4. Employing consumables or oil media that are not appointed by Shini.

2. Structure Characteristics and Working Principle

2.1 Main Functions

For cabinet dryer, materials to be dried are placed on the stainless steel made moveable material trays. During operation, process air will flow to heating wire and be heated up to required temperature, then flow through a manifold with evenly scattered holes. Moisture air is sent out through air exhaust port. It is designed to achieve an even drying effect.

2.2 Working Principle Illustration

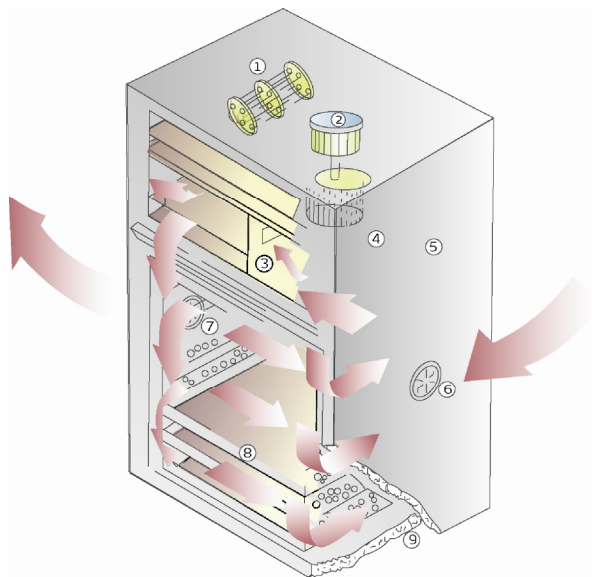

Names of Parts:

- | | | |
|------------------------|-------------------------|-------------------------|
| 1. Heating Coil | 2. Air Inlet Blower | 3. Air Chamber |
| 4. Multi-vane Impeller | 5. Paint-baked Cover | 6. Air Inlet |
| 7. Air Exhaust | 8. Stainless Steel Tray | 9. Heat-resistant Layer |

Picture 2-1: Working Principle Illustration

2.3 Drawing and Parts List

2.3.1 Assembly Drawing (CD-5/9(HT))

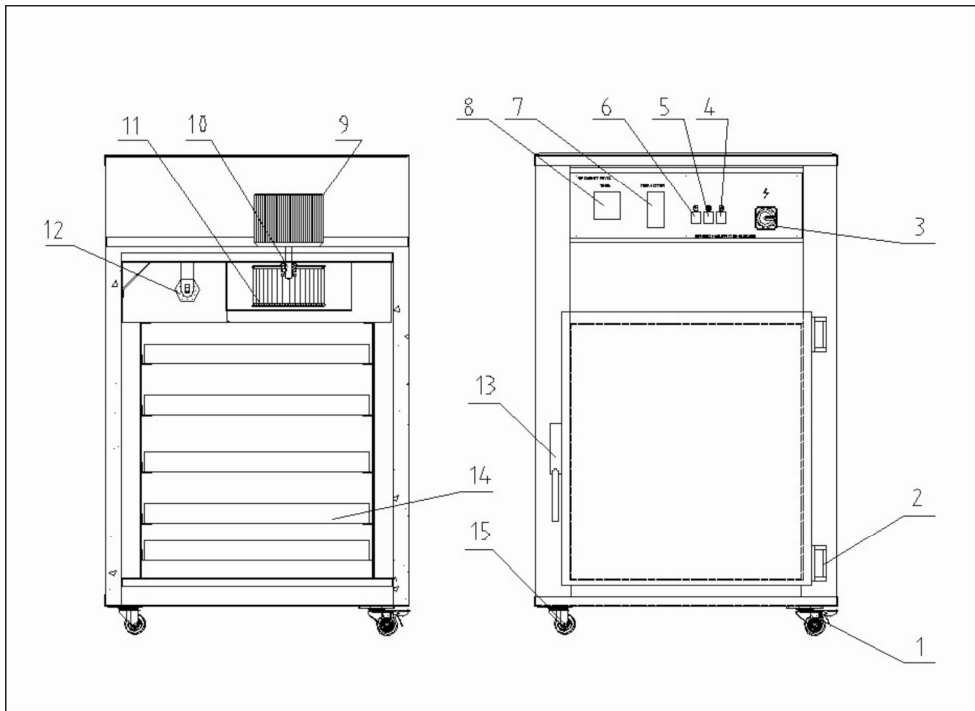

Remarks: Please refer to material list 2.3.2 for specific explanation of the Arabic numbers in parts drawing.

Picture 2-2: Assembly Drawing (CD-5/9(HT))

2.3.2 Parts List (CD-5/9(HT))

Table 2-1: Parts List (CD-5/9(HT))

| No. | Name | Part No. | | |
|-----|------------------------|-----------------|---------------|--------------------|
| | | CD-5-(HT)(60Hz) | CD-9(60Hz) | CD-9-HT(50Hz/60Hz) |
| 1 | 3" mobile castor | YW03000300000 | YW03000300000 | YW03000300000 |
| 2 | Oven door back hinge | BW09000200100 | BW09000200100 | BW09000200100 |
| 3 | The switch | YE10200300000 | YE10200300000 | YE10200300000 |
| 4 | Motor switch | YE10210400000 | YE10210400000 | YE10210400000 |
| 5 | Electric switch | YE10210400000 | YE10210400000 | YE10210400000 |
| 6 | Timer switch | YE10220600000 | YE10220600000 | YE10220600000 |
| 7 | Temperature controller | YE85020000000 | YE85020000000 | YE85020000000 |
| 8 | Timer | YE86002400000 | YE86002400000 | YE86002400000 |
| 9 | Motor | YM10271200000 | YM10271200000 | YM10271200000 |
| 10 | Motor longer shaft | BH11053800010 | BH11053800010 | BH11053800010 |
| 11 | Motor blade | YW09000701100 | YW09000701100 | 50Hz:YW09945140000 |
| | | | | 60Hz:YW09000701100 |
| 12 | Heating wire* | BH70050400050 | BH70094500050 | BH70094500050 |
| 13 | Door lock | YW00000000000 | YW00000000000 | YW00000000000 |
| 14 | Pallet | - | - | - |
| 15 | 3" Fixed castor | YW03000300300 | YW03000300300 | YW03000300300 |

* means possible broken parts. ** means easy broken part. and spare backup is suggested. Please confirm the version of manual before placing the purchase order to guarantee that the item number of the spare part is in accordance with the real object.

2.3.3 Assembly Drawing (CD-20/20L(HT))

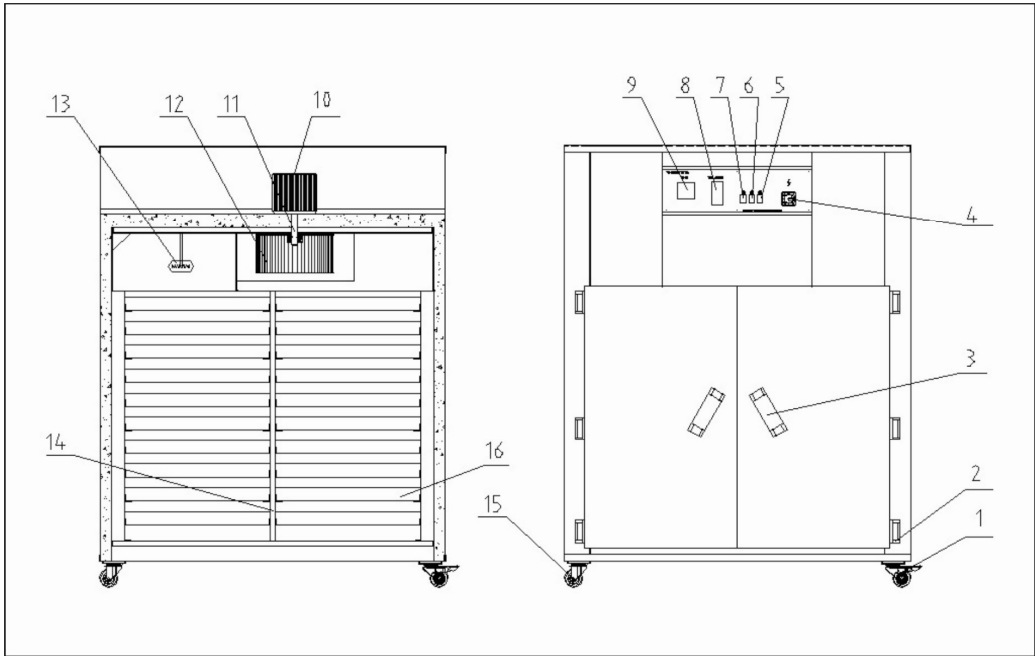

Remarks: Please refer to material list 2.3.4 for specific explanation of the Arabic numbers in parts drawing.

Picture 2-3: Assembly Drawing (CD-20/20L(HT))

2.3.4 Parts List (CD-20/20L(HT))

Table 2-2: Parts List (CD-20/20L(HT))

| No. | Name | Part No. | |
|-----|------------------------|---------------|---------------|
| | | CD-20-(HT) | CD-20L-(HT) |
| 1 | 3" mobile castor | YW03000300000 | YW03000300000 |
| 2 | Oven door back hinge | BW09000200100 | BW09000200100 |
| 3 | Door handle | YW09000300200 | YW09000300200 |
| 4 | The switch | YE10210300000 | YE10210300000 |
| 5 | Motor switch | YE10210400000 | YE10210400000 |
| 6 | Electric switch | YE10210400000 | YE10210400000 |
| 7 | Timer switch | YE10210600000 | YE10210600000 |
| 8 | Temperature controller | YE85020000000 | YE85020000000 |
| 9 | Timer | YE86002400000 | YE86002400000 |
| 10 | Motor | YM10290400000 | YM10290400000 |
| 11 | Motor longer shaft | BH11203600010 | BH11203600010 |
| 12 | Motor blade | YW09001200400 | YW09001200400 |
| 13 | Heating wire* | BH70200900050 | BH70201800050 |
| 14 | Support among | - | - |
| 15 | 3" Fixed castor | YW03000300300 | YW03000300300 |
| 16 | Pallet | - | - |

* means possible broken parts. ** means easy broken part. and spare backup is suggested. Please confirm the version of manual before placing the purchase order to guarantee that the item number of the spare part is in accordance with the real object.

2.4 Electrical Diagram

2.4.1 Main Circuit (400V)

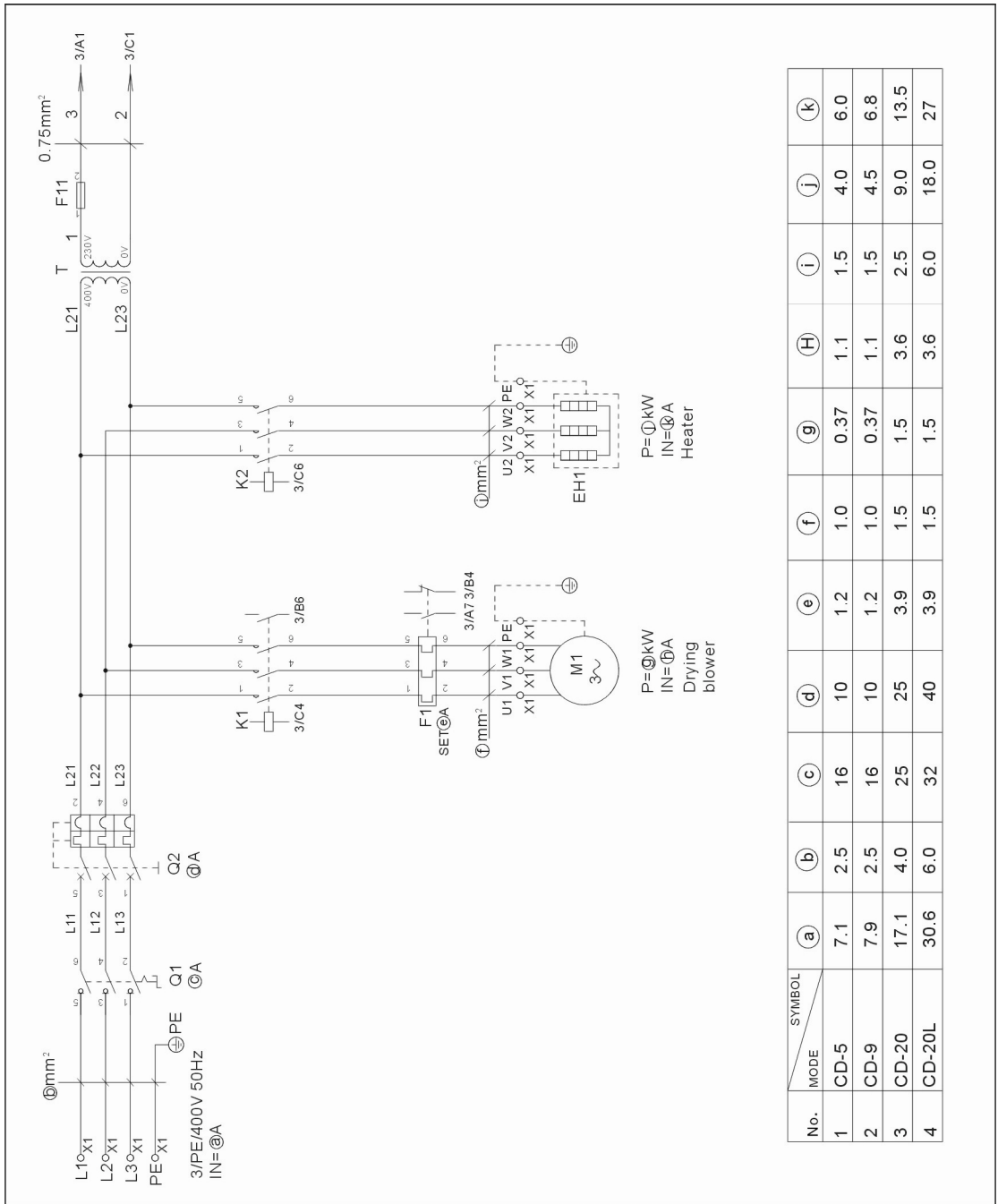

Picture 2-4: Main Circuit (400V)

2.4.3 Components Layout (400V)

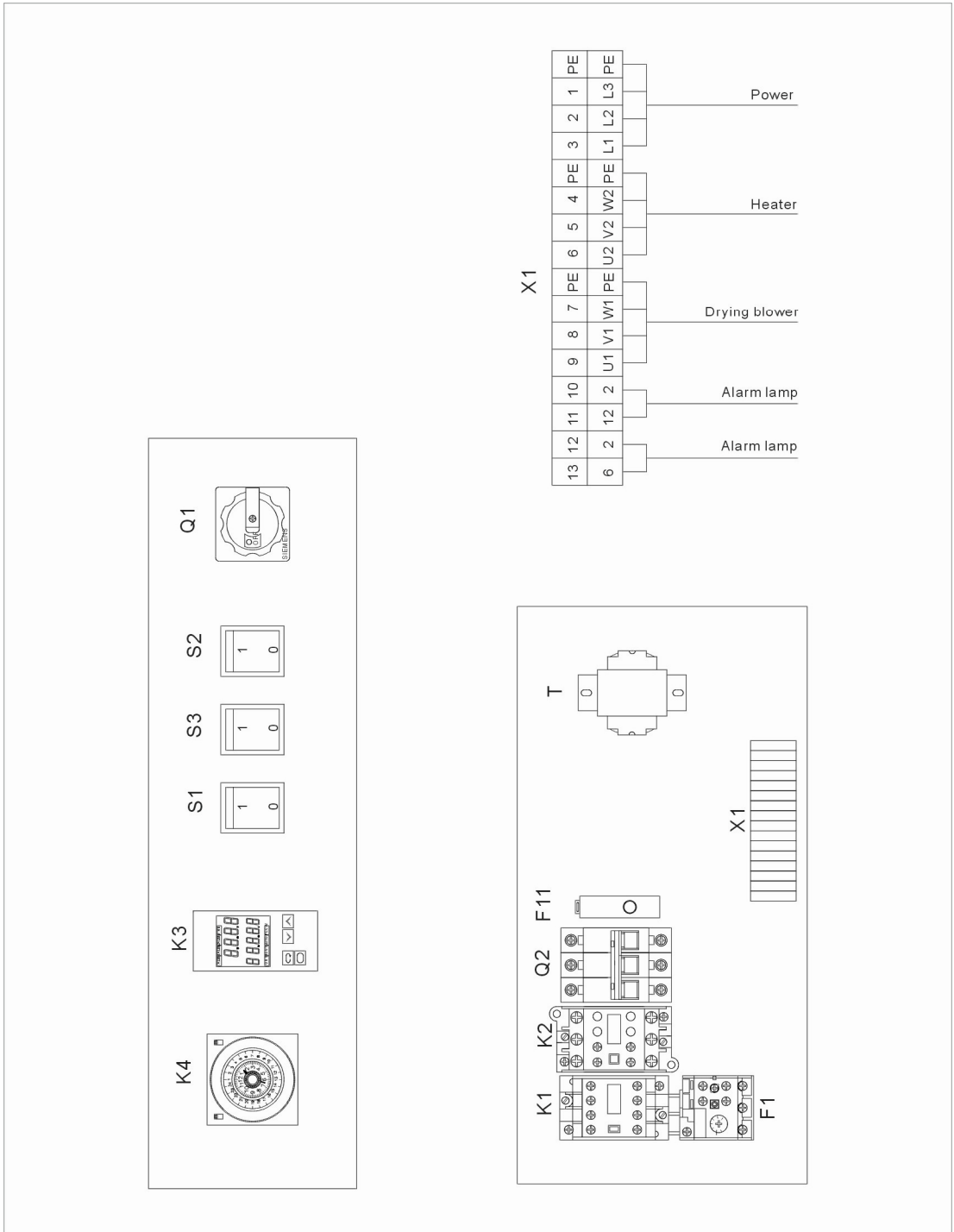

Picture 2-6: Components Layout (400V)

2.4.4 Electrical Components List (400V)

Table 2-3: Electrical Components List (CD-5/CD-5-HT) (400V)

| No. | Symbol | Name | CD-5/CD-5-HT | |
|-----|--------|---------------------|------------------|---------------|
| | | | Specification | Part No. |
| 1 | Q1 | Main switch | 16A | YE10200300000 |
| 2 | Q2 | Circuit breaker** | 10A | YE40600300000 |
| 3 | K1 | Contactor* | 230V 50/60Hz | YE00301000000 |
| 4 | K2 | Contactor* | 230V 50/60Hz | YE00300000000 |
| 5 | K3 | Temp. controller* | 230V 50/60Hz | YE80010200000 |
| 6 | K4 | 24H timer | 230V 50/60Hz | YE86002400000 |
| 7 | F1 | Overload relay* | 1~1.6A | YE01011600000 |
| 8 | F11 | Fuse** | 2A | YE41001000000 |
| 9 | T | Transformer* | 350mA | YE70040000200 |
| 10 | S1 | Control switch | 6P (WH) | YE25801000100 |
| 11 | S2 S3 | Control switch | 4P (WH) | YE10220600000 |
| 12 | S4 | Overheat protector* | 250V 0~300°C | YE10210400000 |
| 13 | S5 | Thermocouple | K | YE21503000200 |
| 14 | H1 | Alarm lamp | 230V 50/60Hz | YM60121200400 |
| 15 | FM | Fan | 230V 50/60Hz | YE83305100200 |
| 16 | X1 | Terminal board | 32A | YE61250000000 |
| 17 | - | - | - | YE61253500000 |
| 18 | M1 | Blower* | 400V 50Hz 0.37kW | YM10003700000 |
| 19 | EH | Heater** | 400V 50Hz 4kW | BH70050400050 |

* means possible broken parts.

** means easy broken part. and spare backup is suggested.

Please confirm the version of manual before placing the purchase order to guarantee that the item number of the spare part is in accordance with the real object.

Table 2-4: Electrical Components List (CD-9/CD-9-HT) (400V)

| No. | Symbol | Name | CD-9/CD-9-HT | |
|-----|--------|---------------------|------------------|---------------|
| | | | Specification | Part No. |
| 1 | Q1 | Main switch | 16A | YE10200300000 |
| 2 | Q2 | Circuit breaker** | 10A | YE40600300000 |
| 3 | K1 | Contactor* | 230V 50/60Hz | YE00301000000 |
| 4 | K2 | Contactor* | 230V 50/60Hz | YE00300000000 |
| 5 | K3 | Temp. controller* | 230V 50/60Hz | YE80010200000 |
| 6 | K4 | 24H timer | 230V 50/60Hz | YE86002400000 |
| 7 | F1 | Overload relay* | 1~1.6A | YE01011600000 |
| 8 | F11 | Fuse** | 2A | YE41001000000 |
| 9 | T | Transformer* | 350mA | YE70040000200 |
| 10 | S1 | Control switch | 6P (WH) | YE25801000100 |
| 11 | S2 S3 | Control switch | 4P (WH) | YE10220600000 |
| 12 | S4 | Overheat protector* | 250V 0~300°C | YE10210400000 |
| 13 | S5 | Thermocouple | K | YE21503000200 |
| 14 | H1 | Alarm lamp | 230V 50/60Hz | YM60121200400 |
| 15 | FM | Fan | 230V 50/60Hz | YE83305100200 |
| 16 | X1 | Terminal board | 32A | YE61250000000 |
| 17 | - | - | - | YE61253500000 |
| 18 | M1 | Blower* | 400V 50Hz 0.37kW | YM10003700000 |
| 19 | EH | Heater** | 400V 50Hz 4kW | BH70094500050 |

* means possible broken parts.

** means easy broken part. and spare backup is suggested.

Please confirm the version of manual before placing the purchase order to guarantee that the item number of the spare part is in accordance with the real object.

Table 2-5: Electrical Components List (CD-20/CD-20-HT) (400V)

| No. | Symbol | Name | CD-20/CD-20-HT | |
|-----|--------|---------------------|-----------------|---------------|
| | | | Specification | Part No. |
| 1 | Q1 | Main switch | 25A | YE10210300000 |
| 2 | Q2 | Circuit breaker** | 25A | YE40602500000 |
| 3 | K1 | Contactor* | 230V 50/60Hz | YE00301000000 |
| 4 | K2 | Contactor* | 230V 50/60Hz | YE00320000000 |
| 5 | K3 | Temp. controller* | 230V 50/60Hz | YE80010200000 |
| 6 | K4 | 24H timer | 230V 50/60Hz | YE86002400000 |
| 7 | F1 | Overload relay* | 3.2~5A | YE01032500000 |
| 8 | F11 | Fuse** | 2A | YE41001000000 |
| 9 | T | Transformer* | 350mA | YE70040000200 |
| 10 | S1 | Control switch | 6P (WH) | YE25801000100 |
| 11 | S2 S3 | Control switch | 4P (WH) | YE10220600000 |
| 12 | S4 | Overheat protector* | 250V 0~300℃ | YE10210400000 |
| 13 | S5 | Thermocouple | K | YE21503000200 |
| 14 | H1 | Alarm lamp | 230V 50/60Hz | YM60121200400 |
| 15 | FM | Fan | 230V 50/60Hz | YE83305100200 |
| 16 | X1 | Terminal board | 41A | YE61040000000 |
| 17 | - | - | - | YE61043500000 |
| 18 | - | Terminal board | 32A | YE61250000000 |
| 19 | - | - | - | YE61253500000 |
| 20 | M1 | Blower* | 400V 50Hz 1.5kW | YM10105000000 |
| 21 | EH | Heater** | 400V 50Hz 9kW | BH70200900050 |

* means possible broken parts.

** means easy broken part. and spare backup is suggested.

Please confirm the version of manual before placing the purchase order to guarantee that the item number of the spare part is in accordance with the real object.

Table 2-6: Electrical Components List (CD-20L/CD-20L-HT) (400V)

| No. | Symbol | Name | CD-20L/CD-20L-HT | |
|-----|--------|---------------------|------------------|---------------|
| | | | Specification | Part No. |
| 1 | Q1 | Main switch | 32A | YE10220300000 |
| 2 | Q2 | Circuit breaker** | 40A | YE40100300000 |
| 3 | K1 | Contactor* | 230V 50/60Hz | YE00301000000 |
| 4 | K2 | Contactor* | 230V 50/60Hz | YE00350000000 |
| 5 | K3 | Temp. controller* | 230V 50/60Hz | YE80010200000 |
| 6 | K4 | 24H timer | 230V 50/60Hz | YE86002400000 |
| 7 | F1 | Overload relay* | 3.2~5A | YE01032500000 |
| 8 | F11 | Fuse** | 2A | YE41001000000 |
| 9 | T | Transformer* | 350mA | YE70040000200 |
| 10 | S1 | Control switch | 6P (WH) | YE25805000000 |
| 11 | S2 S3 | Control switch | 4P (WH) | YE10220600000 |
| 12 | S4 | Overheat protector* | 250V 0~300℃ | YE10210400000 |
| 13 | S5 | Thermocouple | K | YE21503000200 |
| 14 | H1 | Alarm lamp | 230V 50/60Hz | YM60121200400 |
| 15 | FM | Fan | 230V 50/60Hz | YE83305100200 |
| 16 | X1 | Terminal board | 57A | YE61060000000 |
| 17 | - | - | - | YE61063500000 |
| 18 | - | Terminal board | 32A | YE61250000000 |
| 19 | - | - | - | YE61253500000 |
| 20 | M1 | Blower* | 400V 50Hz 1.5kW | YM10105000000 |
| 21 | EH | Heater** | 400V 50Hz 18kW | BH70201800050 |

* means possible broken parts.

** means easy broken part. and spare backup is suggested.

Please confirm the version of manual before placing the purchase order to guarantee that the item number of the spare part is in accordance with the real object.

2.4.5 Main Circuit (230V)

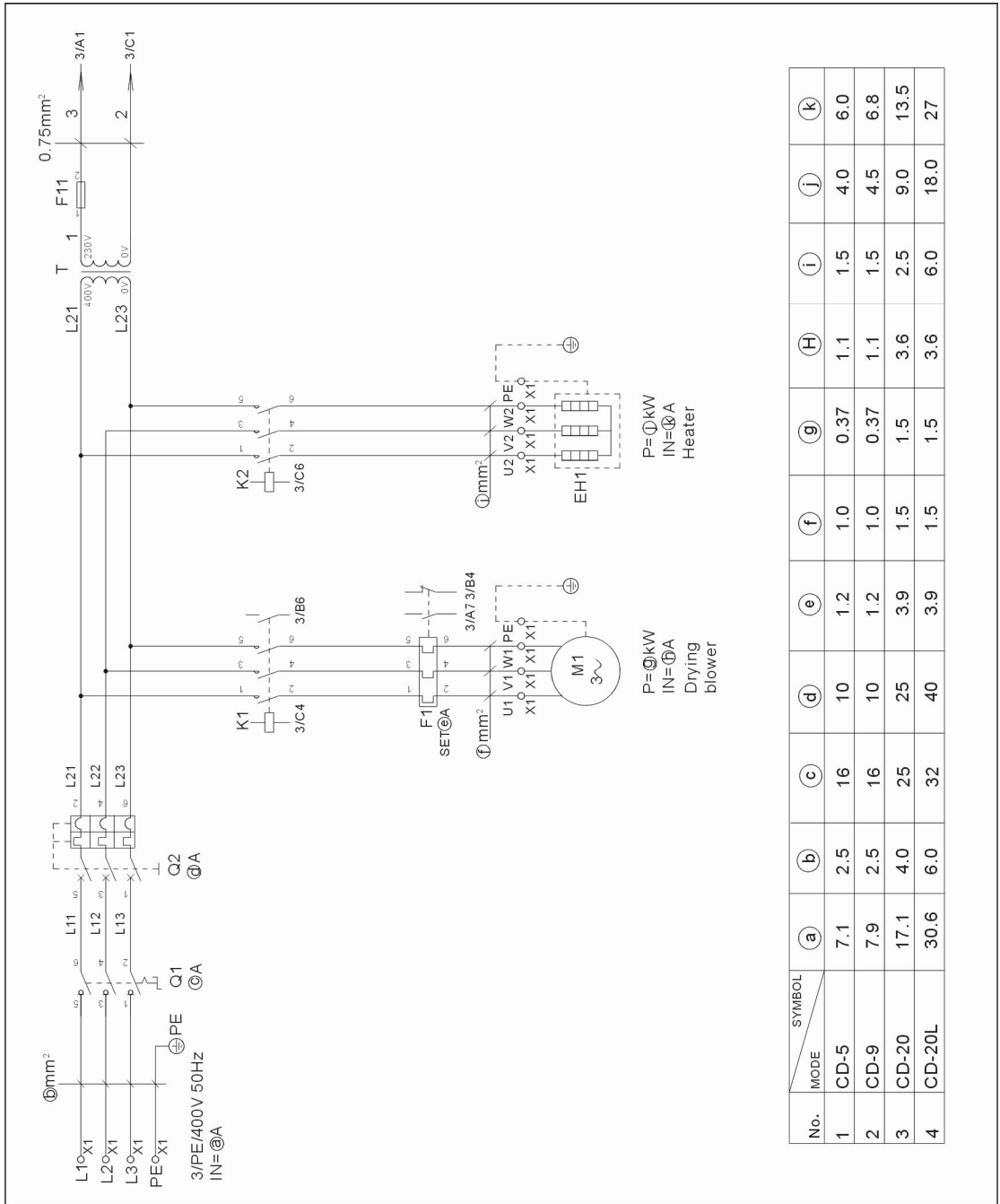

Picture 2-7: Main Circuit (230V)

2.4.6 Control Circuit (230V)

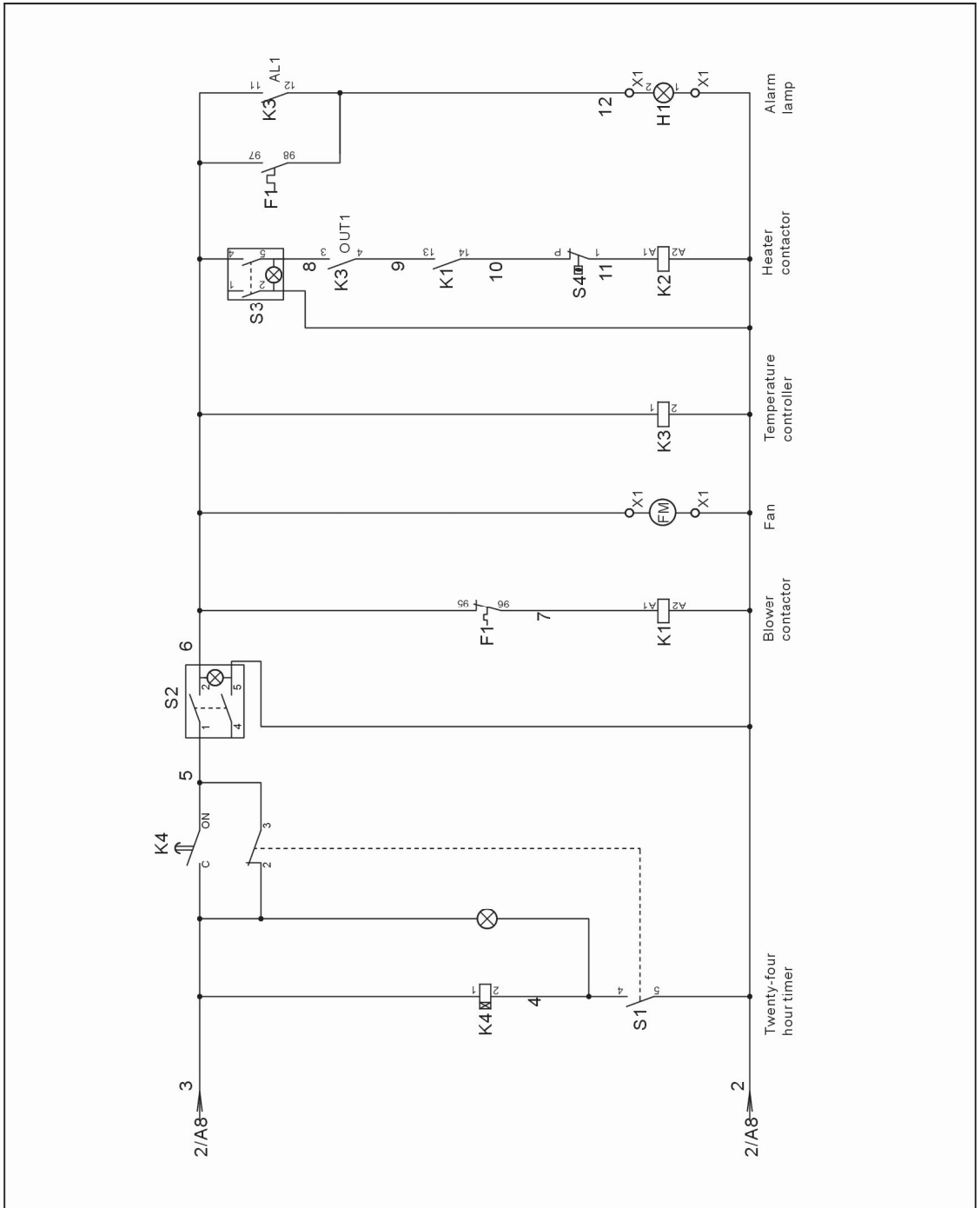

Picture 2-8: Control Circuit (230V)

2.4.7 Components Layout (230V)

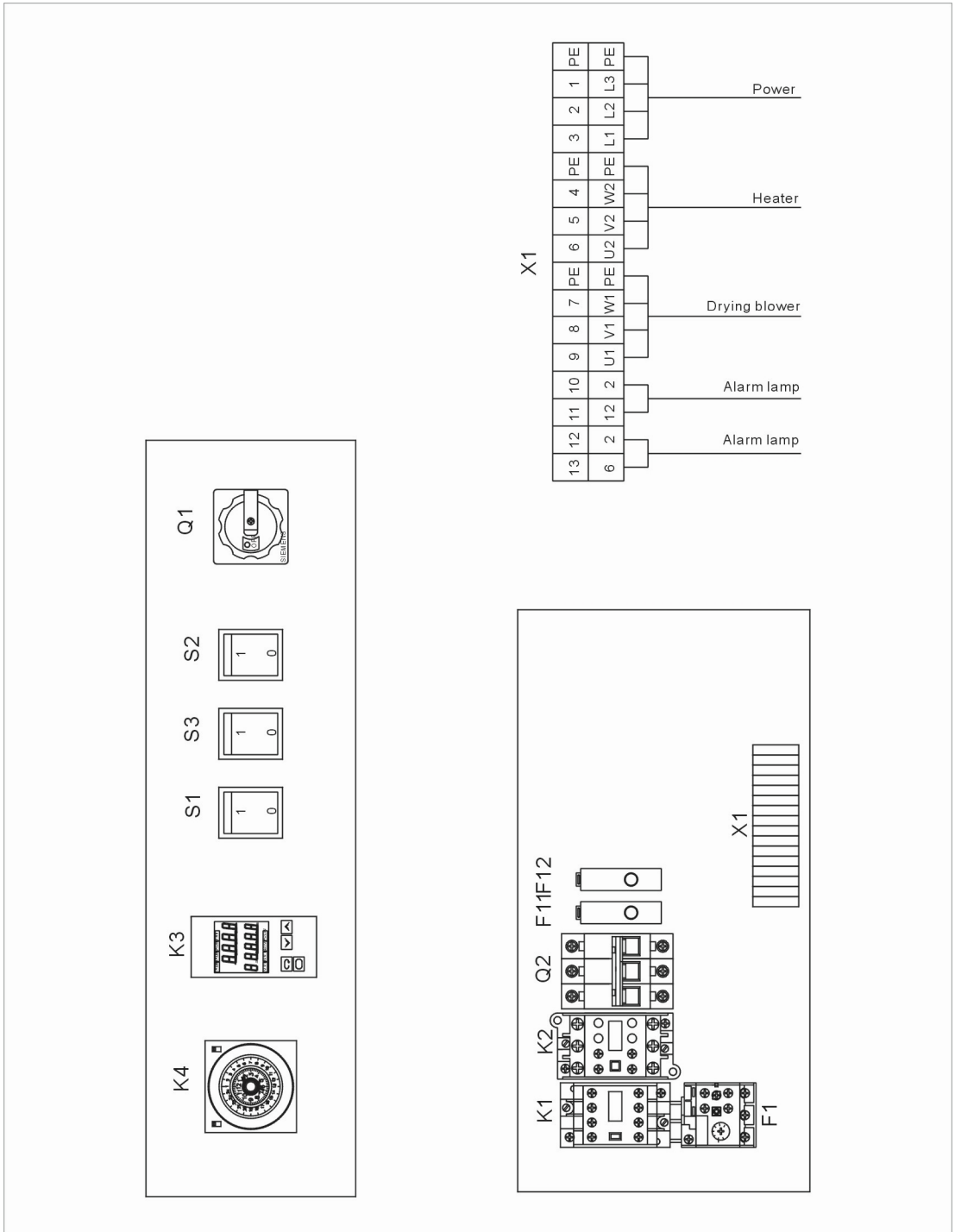

Picture 2-9: Components Layout (230V)

2.4.8 Electrical Components List (230V)

Table 2-7: Electrical Components List (CD-5) (230V)

| No. | Symbol | Name | CD-5 | |
|-----|--------|--------------------|------------------|---------------|
| | | | Specification | Part No. |
| 1 | Q1 | Main switch | 16A | YE10200300000 |
| 2 | Q2 | Circuit breaker** | 20A | YE40602000000 |
| 3 | K1 | Contactor* | 230V 50/60Hz | YE00301000000 |
| 4 | K2 | Contactor* | 230V 50/60Hz | YE00320000000 |
| 5 | K3 | Temp. controller* | 230V 50/60Hz | YE80010200000 |
| 6 | K4 | 24H timer | 230V 50/60Hz | YE86002400000 |
| 7 | F1 | Overload relay* | 1.25~2A | YE01125200000 |
| 8 | F11 | Fuse** | 2A | YE41001000000 |
| 9 | F12 | Ampere meter | 2A | YE25802000000 |
| 10 | S1 | Control switch | 6P (WH) | YE10220600000 |
| 11 | S2 S3 | Control switch | 4P (WH) | YE10210400000 |
| 12 | S4 | Overheat protector | 250V 300°C | YE21503000200 |
| 13 | S5 | Thermocouple | K | BE90015000050 |
| 14 | H1 | Alarm lamp | 230V 50/60Hz | YE61250000000 |
| 15 | FM | Fan | 230V 50/60Hz | YM60121200400 |
| 16 | X1 | Terminal board | 32A | YE61253500000 |
| 17 | - | Terminal board | - | YE61253500000 |
| 18 | M1 | Blower* | 230V 50Hz 0.37kW | YM10003700000 |
| 19 | EH | Heater** | 230V 50Hz 4kW | BH70050400050 |

* means possible broken parts.

** means easy broken part. and spare backup is suggested.

Please confirm the version of manual before placing the purchase order to guarantee that the item number of the spare part is in accordance with the real object.

Table 2-8: Electrical Components List (CD-9) (230V)

| No. | Symbol | Name | CD-9 | |
|-----|--------|--------------------|------------------|---------------|
| | | | Specification | Part No. |
| 1 | Q1 | Main switch | 16A | YE10210300000 |
| 2 | Q2 | Circuit breaker** | 20A | YE40602500000 |
| 3 | K1 | Contactora* | 230V 50/60Hz | YE00301000000 |
| 4 | K2 | Contactora* | 230V 50/60Hz | YE00330000000 |
| 5 | K3 | Temp. controller* | 230V 50/60Hz | YE80010200000 |
| 6 | K4 | 24H timer | 230V 50/60Hz | YE86002400000 |
| 7 | F1 | Overload relay* | 1.25~2A | YE01125200000 |
| 8 | F11 | Fuse** | 2A | YE41001000000 |
| 9 | F12 | Ampere meter | 2A | YE25802000000 |
| 10 | S1 | Control switch | 6P (WH) | YE10220600000 |
| 11 | S2 S3 | Control switch | 4P (WH) | YE10210400000 |
| 12 | S4 | Overheat protector | 250V 300°C | YE21503000200 |
| 13 | S5 | Thermocouple | K | BE90015000050 |
| 14 | H1 | Alarm lamp | 230V 50/60Hz | YE61250000000 |
| 15 | FM | Fan | 230V 50/60Hz | YM60121200400 |
| 16 | X1 | Terminal board | 32A | YE61253500000 |
| 17 | - | Terminal board | - | YE61253500000 |
| 18 | M1 | Blower* | 230V 50Hz 0.37kW | YM10003700000 |
| 19 | EH | Heater** | 230V 50Hz 4kW | BH70094500050 |

* means possible broken parts.

** means easy broken part. and spare backup is suggested.

Please confirm the version of manual before placing the purchase order to guarantee that the item number of the spare part is in accordance with the real object.

Table 2-9: Electrical Components List (CD-20) (230V)

| No. | Symbol | Name | CD-20 | |
|-----|--------|--------------------|-----------------|---------------|
| | | | Specification | Part No. |
| 1 | Q1 | Main switch | 32A | YE10250400000 |
| 2 | Q2 | Circuit breaker** | 40A | YE40605000000 |
| 3 | K1 | Contactor* | 230V 50/60Hz | YE00301000000 |
| 4 | K2 | Contactor* | 230V 50/60Hz | YE00350000000 |
| 5 | K3 | Temp. controller* | 230V 50/60Hz | YE80010200000 |
| 6 | K4 | 24H timer | 230V 50/60Hz | YE86002400000 |
| 7 | F1 | Overload relay* | 5~8A | YE01050800000 |
| 8 | F11 | Fuse** | 2A | YE41001000000 |
| 9 | F12 | Ampere meter | 2A | YE25805000000 |
| 10 | S1 | Control switch | 6P (WH) | YE10220600000 |
| 11 | S2 S3 | Control switch | 4P (WH) | YE10210400000 |
| 12 | S4 | Overheat protector | 250V 300°C | YE21503000000 |
| 13 | S5 | Thermocouple | K | BE90565800050 |
| 14 | H1 | Alarm lamp | 230V 50/60Hz | YE83305100200 |
| 15 | FM | Fan | 230V 50/60Hz | YM60121200400 |
| 16 | X1 | Terminal board | 57A | YE61060000000 |
| 17 | - | Terminal board | - | YE61063500000 |
| 18 | - | Terminal board | 32A | YE61250000000 |
| 19 | - | Terminal board | - | YE61253500000 |
| 20 | M1 | Blower* | 230V 50Hz 1.5kW | YM10105000000 |
| 21 | EH | Heater** | 230V 50Hz 4.5kW | BH70094500050 |

* means possible broken parts.

** means easy broken part. and spare backup is suggested.

Please confirm the version of manual before placing the purchase order to guarantee that the item number of the spare part is in accordance with the real object.

Table 2-10: Electrical Components List (CD-20L)(230V)

| No. | Symbol | Name | CD-20L | |
|-----|--------|--------------------|-----------------|---------------|
| | | | Specification | Part No. |
| 1 | Q1 | Main switch | 63A | YE10250400000 |
| 2 | Q2 | Circuit breaker** | 80A | YE40800300000 |
| 3 | K1 | Contactora* | 230V 50/60Hz | YE00301000000 |
| 4 | K2 | Contactora* | 230V 50/60Hz | YE00482200000 |
| 5 | K3 | Temp. controller* | 230V 50/60Hz | YE80010200000 |
| 6 | K4 | 24H timer | 230V 50/60Hz | YE86002400000 |
| 7 | F1 | Overload relay* | 5~8A | YE01050800000 |
| 8 | F11 | Fuse** | 2A | YE41001000000 |
| 9 | F12 | Ampere meter | 2A | YE25801000000 |
| 10 | S1 | Control switch | 6P (WH) | YE10220600000 |
| 11 | S2 S3 | Control switch | 4P (WH) | YE10210400000 |
| 12 | S4 | Overheat protector | 250V 300°C | YE21503000200 |
| 13 | S5 | Thermocouple | K | BE90565800050 |
| 14 | H1 | Alarm lamp | 230V 50/60Hz | YE83305100200 |
| 15 | FM | Fan | 230V 50/60Hz | YM60121200400 |
| 16 | X1 | Terminal board | 101A | YE61160000000 |
| 17 | - | Terminal board | - | YE61163500000 |
| 18 | - | Terminal board | 32A | YE61250000000 |
| 19 | - | Terminal board | - | YE61253500000 |
| 20 | M1 | Blower* | 230V 50Hz 1.5kW | YM10105000000 |
| 21 | EH | Heater** | 230V 50Hz 18kW | BH70201800050 |

* means possible broken parts.

** means easy broken part. and spare backup is suggested.

Please confirm the version of manual before placing the purchase order to guarantee that the item number of the spare part is in accordance with the real object.

2.4.9 Main Electrical Components Description

Overload Relay

At delivery, the overload relay is set for manual reset. (the reset button pointing to H). Manually reset the relay at the tripping of the switch. When motor overload occurs, stop the machine, then check and solve the problem. After that open the door of control box, press down the reset button of overload relay (if you can not press down the reset button, wait for one minute).

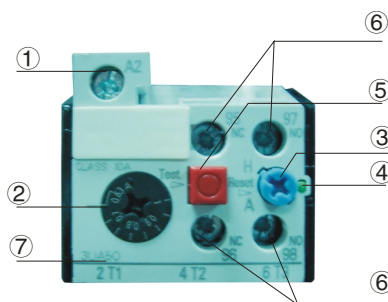

Picture 2-10: Overload Relay

- 1) Terminal for contact coil A2.
- 2) Setting current adjusting scale.
- 3) Reset (blue).

H: manual reset

A: automatic reset

- 4) Switch position indication (green).

Tripping of a manual-resetting is indicated by a pin projecting from the front plate.

- 5) Test button (red).
- 6) Auxiliary contact terminals shown in 95.96.97.98. NC and NO contacts are shown in position 95.96. and 97.98. respectively.
- 7) Main circuit connection No. must be correspond with terminal Number of contactor.

3. Installation and Debugging

Install the CD Cabinet Dryer at a proper place where is easy for service and maintenance.

3.1 Attentions During Installation

- 1) Make sure voltage and frequency of the power source comply with those indicated on the manufacture's plate, which is attached to the machine.
- 2) Power cable and earth connections should conform with local regulations.
- 3) Use independent power cable and ON/OFF switch. The cable's size should not smaller than those applied in the control box.
- 4) The power cable connection terminals should be tightened securely.
- 5) The machine requires a 3-phase 4-wire power source, connect the power lead (L1, L2, L3) to the live wires, and the earth (PE) to the ground.
- 6) Power supply requirements:
Main power voltage: $\pm 5\%$
Main power frequency: $\pm 2\%$

3.2 Machine Ins Tallation Distance



Picture 3-1: Machine Ins Tallation Distance



Note!

Keep the machine 2M from the combustibile distance.

3.3 Check the Rotation Direction of Blower

- 1) Check whether the wind direction of inlet and outlet on the two sides of oven is right.
- 2) If the rotation direction is not right:
 - a) Stop the machine.
 - b) Turn off the main switch.
 - c) Change any two lines of the main power supply 's three lines.
 - d) Stop the machine, and check it again.



Picture 3-2: Blower Inlet / Outlet

4. Application and Operation

Open the distribution box and connect the power source in accordance with wiring diagram. Make sure that the power voltage is in compliance with the required specifications.







Notes!

Before connecting, the main switch and heat switch should be off.

4.1 Test

After all wires are connected, turn the main switch and the heater switch to “ON”, then the pilot lamp light, observe if the rotating direction of blower is consistent with the arrow. If not, exchange any two power cables.

4.2 Setting Temperature

Firstly press key , then press keys   to adjust temperature , finally press confirmative key  to confirm the adjusting. Use temperature adjustor together with material dry thermometer to set the temperature. After heating for a period of time, the yellow light and red light will flash alternatively, which indicates that the setting temperature value has been reached, at that time the actual temperature of temperature controller and setting temperature are the same.





Picture 4-1: Temp. Controller

4.2.1 Keys Operature Instruction

Parameter layer selection key



- 1) If select this key under common condition, system will enter Parameter layer selection mode, and press this key again to Select parameter layer. If want to enter parameter mode, please Press  key.
- 2) If press this key under parameter mode, system will out of the parameter mode and enter the parameter layer selection mode.
- 3) Under setting mode, press the selection key to store the parameters and out of the setting mode, enter the parameter mode.
- 4) Under all modes, press this key  for 2 seconds to skip back to common condition.

Setting keys



- 1) Under common mode, press setting key to set the 'setting value' directly.
- 2) Under parameter layer selection mode, press setting key to skip back the last parameter layer.
- 3) Under parameter mode, press this key, system will enter setting mode, and may set the parameters.
- 4) Under setting mode, press setting key to select the setting numbers or store the parameters and skip back the parameter mode.

Up key



- 1) Under parameter layer selection mode, press up key to enter parameter mode.
- 2) Under parameter mode, press up key to select the parameters of this parameter layer.
- 3) Under setting mode, press up key to increase the parameters' value until their upper limit.

Down key



- 1) Under parameter layer selection mode, press down key to enter parameter mode.
- 2) Under parameter mode, press down key to select the parameters of this parameter layer.
- 3) Under setting mode, press down key to increase the parameters' value until their lower limit.

4.3 Adjustment of Air Rate

Adjustment of air rate is the most important factor for the drying result, should adjust the air outlet and inlet when drying different material.

For example:

- 1) When heat and brake the electronic, galvanized and baked-finish products, the air-inlet and air-outlet should be closed completely.
- 2) When dry up the plastic materials and other products contained much moisture, the air-inlet and air-outlet should be opened properly.



Picture 4-2: Adjustment of Air Rate

4.4 Start-up Timer Setting

Turn on timer switch after all switch has been on, take down the glassy shield outside of the timer, then push the small black switch to "Auto". Set current time and drying time required, cover the glassy shield. Therefore the cabinet dryer will run automatically till drying time.

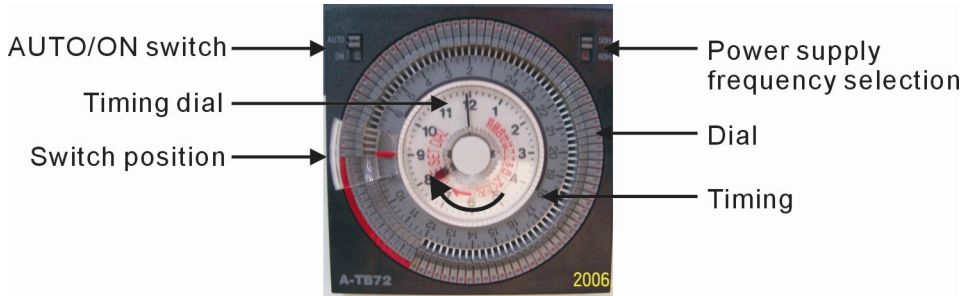

Picture 4-3: Start-up Timer Setting

Output setting

Open setting: Reverse the setting section of dial inward, at this time, red mark appears in the dial.(shown in the above picture)

Close setting: Reverse the setting section of dial to the outside, the red mark disappears, then rotate the timing dial to the switch position.

4.5 Setting the Over-thermal Protector

Over-thermal protector will be used when the actual heating temperature exceeds the setting temperature to protect the motor and heater. And its setting temperature should be higher than that of thermometer.



Picture 4-4: Setting the Over-thermal Protector

5. Trouble-shooting

| Fault | Possible reasons | Solution |
|--|---|------------------------------------|
| It doesn't start after turning on the main switch. | 1. The motor switch isn't open. | 1. Turn on the motor switch. |
| | 2. The fuse is broken. | 2. Replace a new fuse. |
| | 3. The transformer is burnt out. | 3. Replace a new transformer. |
| The motor doesn't run. | 1. The motor switch isn't open. | 1. Turn on the motor switch. |
| | 2. The circuit breaker trips. | 2. Press "RESET" key. |
| | 3. The magnet contactor breakdowns. | 3. Replace a new magnet contactor. |
| | 4. The motor is burned out. | 4. Replace a new motor. |
| The temperature is abnormal. | 1. The temperature controller breakdowns. | 1. Replace it. |
| | 2. The temperature contactor breakdowns. | 2. Replace it. |
| | 3. The magnet contactor breakdowns. | 3. Replace it. |
| | 4. The heater breakdowns. | 4. Replace it. |

6. Maintenance and Repair

Clear off the dust on the motor fan periodically, avoid the damage to the blower.

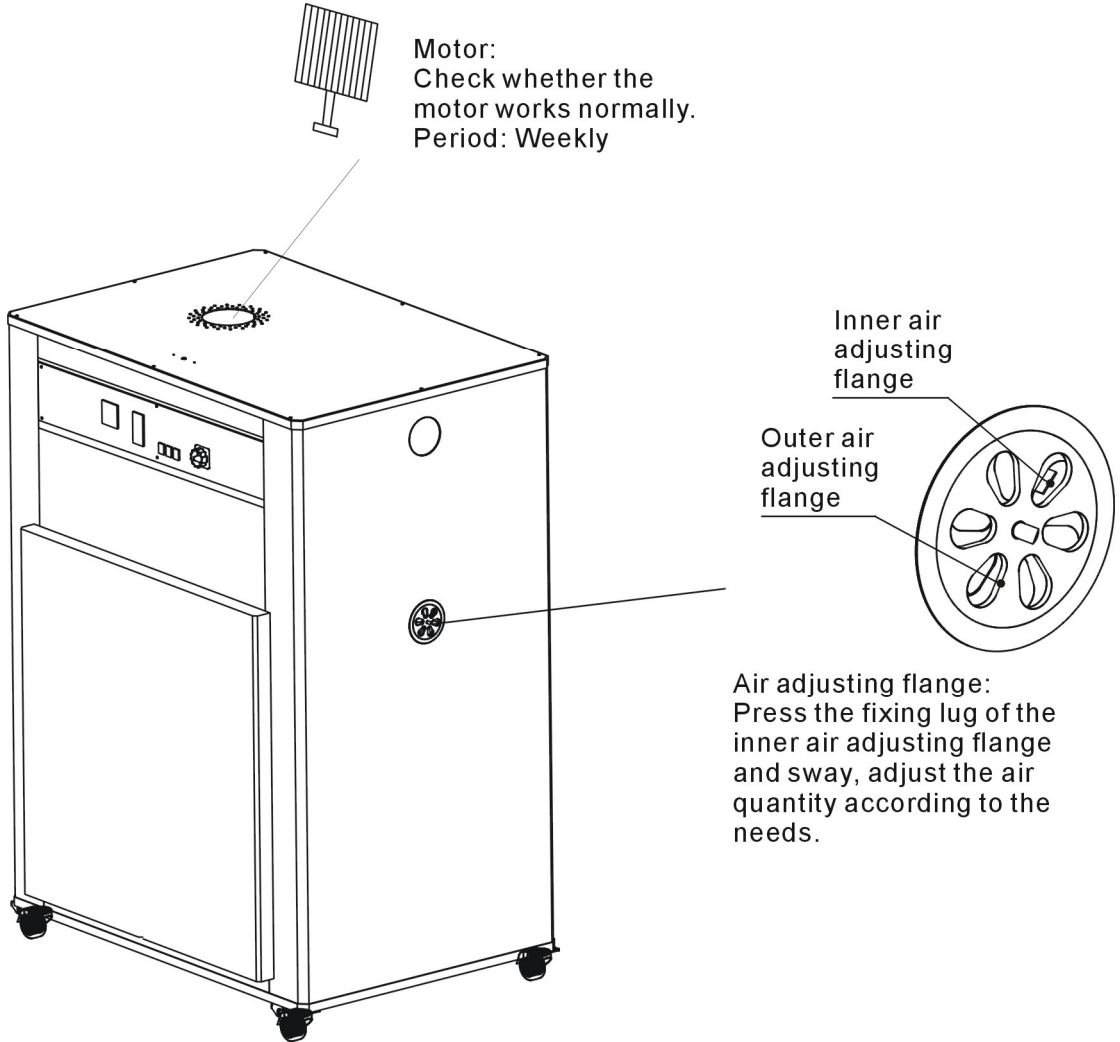

6.1 Maintenance Schedule

6.1.1 About the Machine

Model _____ SN _____ Manufacture date _____

Voltage _____ Φ _____ V Frequency _____ Hz Power _____ kW

6.1.2 Electrical Installation

Voltage: _____ V _____ Hz

Fuse melt current: 1 Phase _____ A 3 Phase _____ A

Check phase sequence of the power supply.

6.1.3 Daily Checking

Check power supply wires.

Check the start/stop function.

6.1.4 Weekly Checking

Check the switches of the machine.

Check all the electrical wires.

Check the pipe heater.

Check motor overload relay.

6.1.5 Monthly Checking

Check the switches and automatism on-off of the machine.

Check the pipe heater.

Check if there are loose electrions.