

PNL Series

Belt Conveyor

Date: Aug, 2017

Version: Ver.B (English)



Contents

1. General Description	5
1.1 Coding Principle	6
1.2 Feature	6
1.3 Technical Specifications	8
1.3.1 Dimensions	8
1.4 Safety Regulations	9
1.4.1 Safety Signs and Labels	9
1.5 Exemption Clause	11
2. Structural Features and Working Principle	12
2.1 Function Description	12
2.1.1 Working Principle	12
3. Installation Testing	14
3.1 Attention	14
3.2 Horizontal Installation	14
3.3 Power Connections	15
4. Operation	16
4.1 Adjustment of the Height of the Conveyor	16
4.2 Adjusting Adjustor Panel	16
4.3 Adjusting the Central Position of the PU Belt	17
5. Trouble Shooting	19
6. Service and Maintenance	20
6.1 Repair	20
6.2 Maintenance	20
6.2.1 Maintenance of the Gear Motor	20
6.2.2 Clearance of the Machine	21
6.2.3 Lubricate the Bearing	22
6.3 Maintenance Schedule	23
6.3.1 About the Machine	23
6.3.2 Check After Installation	23

6.3.3 Daily Checking.....	23
6.3.4 Weekly Checking.....	23

Table index

Table 1-1: Dimensions List	8
----------------------------------	---

Picture index

Picture 1-1: Dimensions.....	8
Picture 2-1: Working Principle	12
Picture 3-1: Horizontal Installation	14
Picture 3-2: Power Connections	15
Picture 3-3: Machine Installation Drawing.....	15
Picture 4-1: Conveyor Belt Adjusting Drawing	16
Picture 4-2: PVC Adjusting Drawing	17
Picture 6-1: Gear Motor	21
Picture 6-2: Bearing Lubricate Drawing	22

1. General Description



Please read this manual carefully before using this machine in order to operate correctly against any damage caused due to improper operation.



Forbidden to process flammable or toxic material!

Shini manufactures four types of belt conveyor under technical license from a leading European manufacturer.

PNL series conveyor feature reliable performance and ease of operation and are suitable for use with CB or SV series conveyor or as stand-alone units.



Model: PNL-2

1.1 Coding Principle

PNL - x - Lxxxx

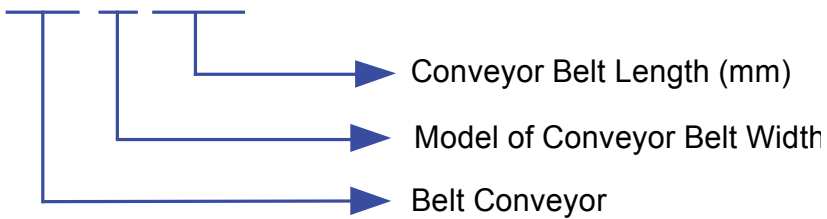

1.2 Feature

- Mounted on patented "FUTURE" floor stand.
- PVC belt is adopted for smooth and efficient conveying.
- Height adjustable floor stand. PNL series has angel adjustable function with a range of $0^{\circ} \sim 25^{\circ}$.
- Sidewalls for PNL series are 75 mm respectively
- The conveying speed of PNL series is 6.5m/min
- equipped with channel metal detector to detect effectively the metal in the channel
- Maximum loading capacity of PNL series is 56kg.
- Frequency converter is optional for PNL series , of which the normal and safe speed range is 3~6.5 m/min.
- PNL series can optionally material fence to facilitate regrind conveying.
- Power supply for PNL series are 1Φ, 400VAC, 50/60Hz.

All service work should be carried out by a person with technical training or corresponding professional experience. The manual contains instructions for both handling and servicing. Chapter 6, which contains service instructions intended for service engineers. Other chapters contain instructions for the daily operator.

Any modifications of the machine must be approved by SHINI in order to avoid personal injury and damage to machine. We shall not be liable for any damage caused by unauthorized change of the machine.

Our company provides excellent after-sales service. Should you have any problem during using the machine, please contact the company or the local vendor.

Headquarter and Taipei factory:

Tel: (886) 2 2680 9119

Shini Plastics Technologies (Dongguan), Inc:

Tel: (86) 769 8111 6600

Shini Plastics Technologies India Pvt.Ltd.:

Tel: (91) 250 3021 166

1.3 Technical Specifications

1.3.1 Dimensions

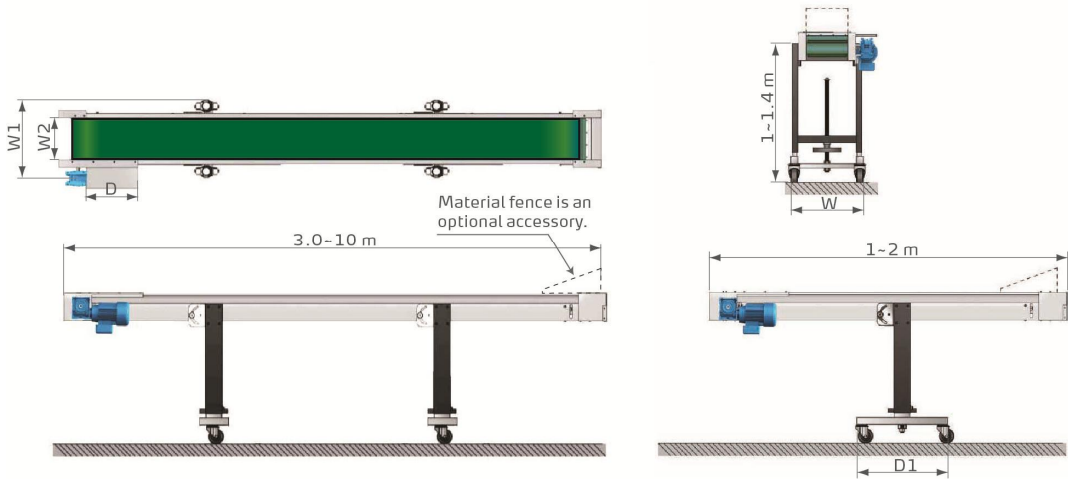

Picture 1-1: Dimensions

Table 1-1: Dimensions List

Model	PNL-1	PNL-2	PNL-3	PNL-4	PNL-5	PNL-6	PNL-7	PNL-8
W (mm)	440	520	590`	720	820	1020	1220	1420
W1 (mm)	450	530	600	730	830	1030	1230	1430
W2 (mm)	220	300	370	500	600	800	1000	1200
D (mm)	500	500	500	500	500	500	500	500
D1 (mm)	650	650	650	650	650	650	650	650
Weight (kg)	93	100	106	117	126	143	160	180

We reserve the right to change specifications without prior notice.

1.4 Safety Regulations

To avoid any body injuries and damages of the machine, please obey the regulations in this manual. When operating this machine, please obey the regulations as follows.

1.4.1 Safety Signs and Labels



Electrical installation should be done by qualified electricians. Turn off the main switch and control switch before servicing and maintenance.



Warning!

The sound level produced by the machine is < 70dB (max) at the position of the operator.



Notice:

Noise level test refers to the following conditions: 1m around the machine, 1.6m above the machine.



Warning!

- 1) Don't use the machine and don't try to repair it before carefully read this manual and understood all its parts completely.
- 2) In particular, it is important to adopt the precaution listed in section a 'safety instruction'.
- 3) It is forbidden to use the machine in any condition or for any use different from what is indicated in the manual. SHINI has no responsibility for breakdowns, trouble, or injuries caused by improper operation.



Attention!

No need for regular inspection because all the electrical parts in the control unit are fixed tightly!



Attention!

The maximum weight of the pieces to be carried on the conveyor belt must not be over 56kg in total (Conveying capacity is less than 56kg as

the set value of the regulator is smaller than 4.5m/min).

The conveyor belts are not suitable to transport loose material.



Attention!

These conveyor belts can be easily used by all of the personnel of the plant they are installed in, and they do not present any risk for the operator, if used properly.

Therefore, it is recommended to read the manual carefully before using the machine.



Attention!

SHINI claims no responsibility when:

- 1) Use of the conveyor belt is in any way openly opposed to what is indicated in the present instruction manual.
- 2) There are feeding defects.
- 3) There is a serious deficiency of the foreseen maintenance.
- 4) Non-authorized changes are adopted.
- 5) Spare parts that are non-authorized or not suitable for the actual model are used.
- 6) There are exceptional events. Please don't disassemble the protector sponge and quick tube & nip in the outlet of collecting material box.



Danger!

Risk of fire: Risk of fire is present whenever the conditions of the conveyor belts are not suitable for the operation they are used for (in particular: temperature of the pieces carried). Adjust the condition of the conveyor belt according to the table shown here below.



Risks of high temperature: These conveyor belts are designed for transporting molded parts, i.e. hot pieces. If you need to operate on the conveyor belt, use safety gloves (in particular where the parts fall on the belt).

Type of belt	Max. temp. of parts
PVC	60°C



Attention!

The packing material must not be left around, and it must be disposed of according to the regulations in force. It is possible to lift the conveyor with a fork lift.



Danger!

To protect the operator's safety, and the integrity of the machine, assure the stable lifting of the conveyor. Once the conveyor belt is running, it is necessary to fix the machine by locking the castors. Moreover, suitable slings or fixtures must be attached, to keep it steady during transportation.

1.5 Exemption Clause

The following statements clarify the responsibilities and regulations born by any buyer or user who purchases products and accessories from Shini (including employees and agents).

Shini is exempted from liability for any costs, fees, claims and losses caused by reasons below:

1. Any careless or man-made installations, operation and maintenances upon machines without referring to the Manual prior to machine using.
2. Any incidents beyond human reasonable controls, which include man-made vicious or deliberate damages or abnormal power, and machine faults caused by irresistible natural disasters including fire, flood, storm and earthquake.
3. Any operational actions that are not authorized by Shini upon machine, including adding or replacing accessories, dismantling, delivering or repairing.
4. Employing consumables or oil media that are not appointed by Shini.

2. Structural Features and Working Principle

2.1 Function Description

PNL series conveyor feature reliable performance and ease of operation and are suitable for use with CB or SV series conveyor or as stand - alone units.

2.1.1 Working Principle

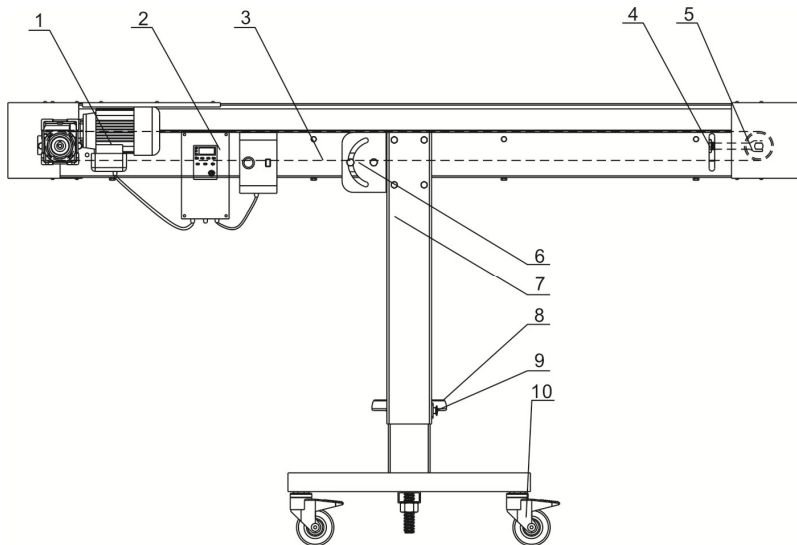

Parts name:

- | | | | |
|------------------|------------------------|-------------|------------------------|
| 1. Gearmotor | 2. Frequency converter | 3. PVC belt | 4. Adjusting screw nut |
| 5. Plug in screw | 6. Adjusting board | 7. Base | 8. Driving wheel |
| 9. Star knob | 10. Castor with brake | | |

Picture 2-1: Working Principle

The conveyor belts of this series are made up of:

Equipped with a 4 swivel castors (10) and locking facility support frame (7), the conveyor belt can be easily moved to the working area. The conveying rotor located on the top end is directly connected to the gear motor (1). The inverter (2) is optional to adjust the speed of the conveyor belt. The screw nut (4) connected to the butterfly screw (5), is used for adjusting the height of conveyor, and there are two knobs will be used for controlling the moving direction and tightness degree.

Moreover, the belt is connected to the support frame, so it is possible to change its inclination by adjusting the two bolts.

Generally speaking , the operator will stand at the conveyor top end (discharging area), and the controlling parts are located here as well.

3. Installation Testing

Read this chapter carefully before installation, Must observe the installation steps as follows!

The connection of the power supply should be done by qualified electricians only!

3.1 Attention

- 1) Verify that the power supply corresponds to the specifications of the plate near the controls of the conveyor.
- 2) Connect the power cable and the PE wire according to the local regulations.
- 3) Use independent power cable and switch, Make sure that the diameter of the cable is not smaller than the cable used in the control box.
- 4) The connection end of the power cable should be safely and tightly.
- 5) This series use the power with 3phase and 4wire, (L) connect to the live wire of the power, and the PE should be connected.
- 6) Power supply requirement:
Main power voltage: $\pm 10\%$
Main power frequency: $\pm 2\%$

3.2 Horizontal Installation

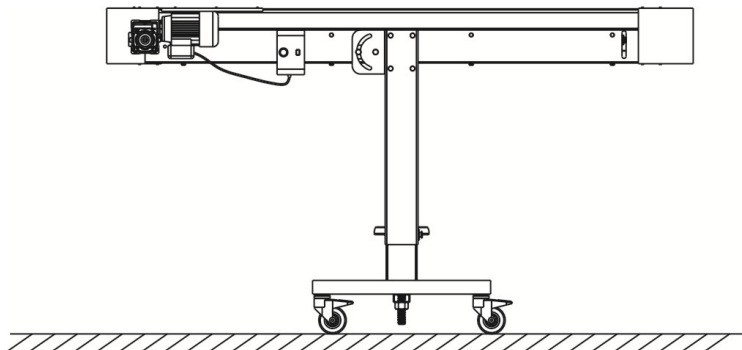

Picture 3-1: Horizontal Installation

Conveyor don't require any particular preliminary operation before starting-up. With reference to the layout of the cables, make sure that they are protected against damage and that they don't hamper the operators.

3.3 Power Connections

The wire of the horizontal belt conveyor, speed regulator and motor protector should be connected strictly comply with the wiring diagram.

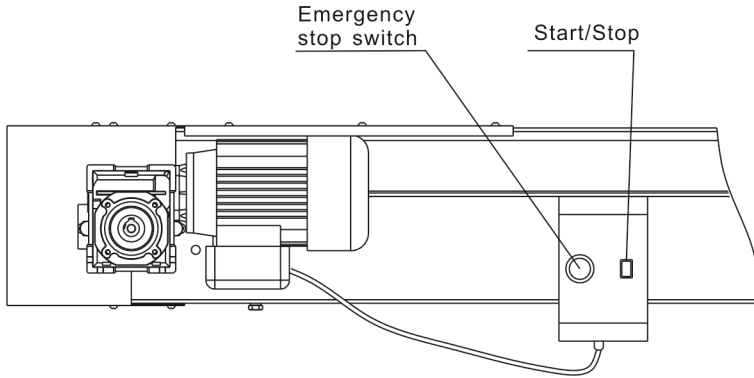

Picture 3-2: Power Connections

Attention: After the power connected, check the direction of the motor rotation, if the motor reverses, please turn off the power, and change any pair of the power cable.

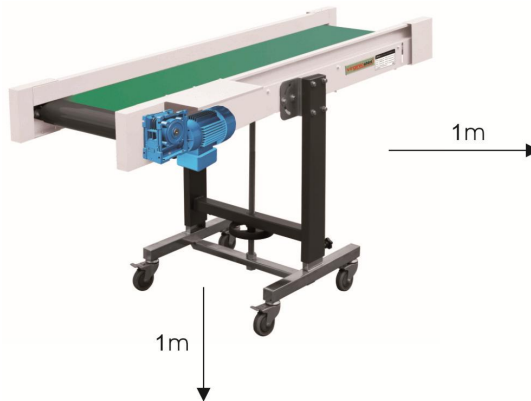

Picture 3-3: Machine Installation Drawing

4. Operation

4.1 Adjustment of the Height of the Conveyor

Loosen the plum flower screw (3), turn the rotation wheel (1), adjust conveyor to demand height, and then tighten the plum flower screw (3).

Attention: When adjusting the height, please lift up or support the conveyor to prevent falling, human injury or machine damage.

4.2 Adjusting Adjustor Panel

Loosen the lockup adjusting screw (2) to adjust the conveyor belt to the required height, and then tighten the screw again (2).

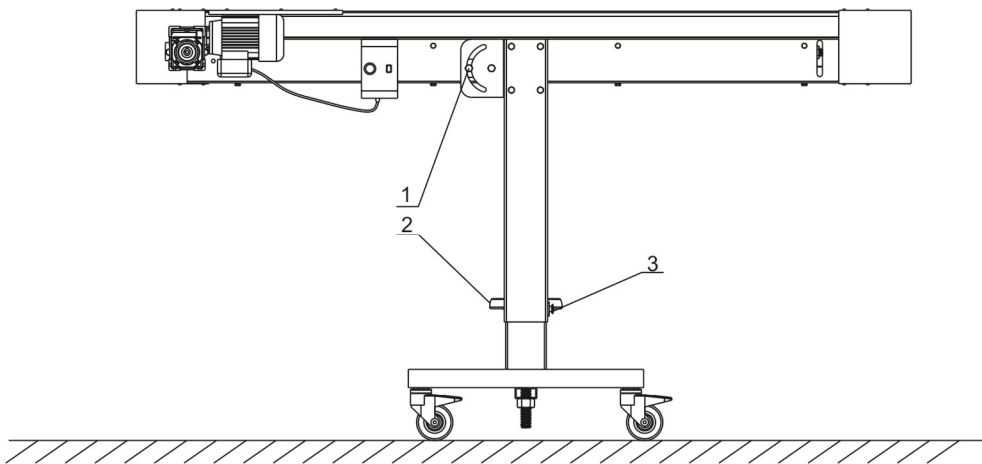

Picture 4-1: Conveyor Belt Adjusting Drawing

Adjustable gradient is 0°~25°!

If the screw does not locked after adjusting the conveyor belt, the conveyor belt will lost its balance!

4.3 Adjusting the Central Position of the PU Belt

Rotate this nut to adjust the central space of the PU Belt

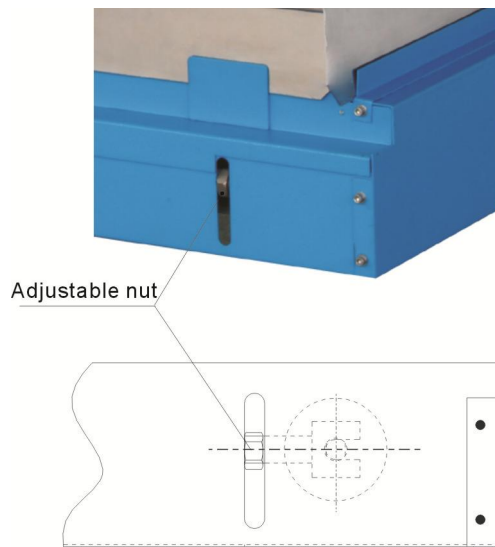

Picture 4-2: PVC Adjusting Drawing



Danger!

To check the proper centering it is necessary to make the machine run. However, the adjustment must be done when the machine is stopped, and then the belt must be made to run only for the time necessary to verify its proper centering.



Attention!

On a monthly basis verify that the external temperature of the motor and gearbox is not too high (it should be between 60 and 20°C). In case it is different, contact the technicians at SHINI directly.



Attention!

- 1) The maximum weight of the pieces to be carried on the conveyor belt must not be over 56kg in total(Conveying capacity is less than 56kg as the set value of the regulator is smaller than 4.5m/min)..
- 2) Not suitable to transport loose material.
- 3) The maximum resistant temperature of PU belt is 60°C.



The operator, or the maintenance technician, must wear suitable work clothes, without free parts. They must not wear chains, bracelets, or other objects which may be caught by mechanical parts in movement. In case of long hair, special hairnets must be used, to avoid the risk of being caught.

5. Trouble Shooting

Failures	Solutions
Connect the power, rotate the motor protector knob and turn on the RUN / STOP switch of the speed regulator, the motor doesn't run.	1. Check the circuit according to wiring diagram, the possible reasons can be as follows: a: The power is failure. b: The circuit is disconnected. c: The motor protector is damaged. d: The motor is failure.
The circuit breaker often trips off.	Check the circuit according to wiring diagram, the possible reasons can be as follows: a: The setting value of the breaker was too low, adjust the value to 1.1 times of the current one. b: Short circuit may exist. c: The motor protector is damaged. d: The motor is failure.

6. Service and Maintenance

Check whether there is oil leakage of the gear motor. Period: Daily
The lubricate oil in the gears box should be replaced after it has been run 400hr at the beginning, and after that the oil replacing periods is about 4,000hr. The lubricate oil in the gear motor must be sufficient. Replenishment or renewal must be done when there is oil leakage or lube degeneration. Period: Monthly.

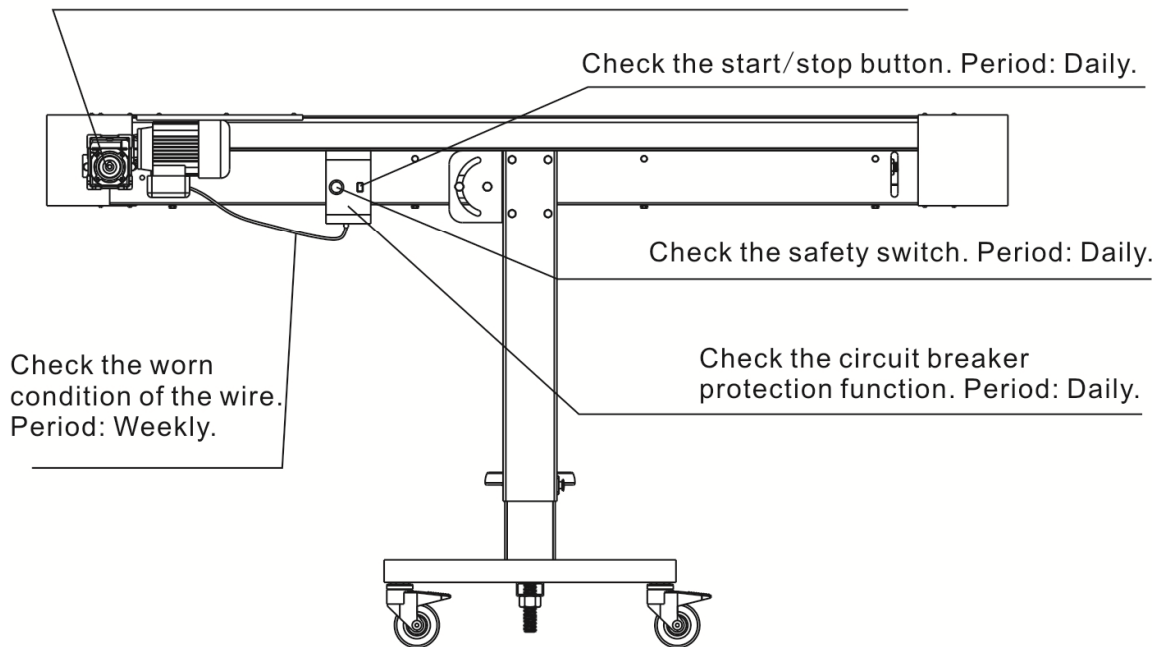

6.1 Repair

To avoid any body injury and damage of the machine, all of the repair work should be done by professional person only.

It is the duty of the operator to keep the machine clean from foreign matter, such as deposits, oil, or other materials. So it is necessary to clean the machine at the end of every working shift. This must be performed when the machine is stopped, in stable starting of the machine.

6.2 Maintenance

6.2.1 Maintenance of the Gear Motor

Check if the reduced gears box is oil leaking and it should be examined periodicity. When you find that the oil is reduced or the color of it changed dark and black, you must complement it or replace it immediately. Please be noticed that keep the

surface of the gear motor cleaning. Move away the dust and the contamination in time so as to keep a good distribute of the heat.

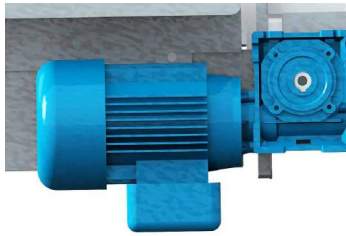

Picture 6-1: Gear Motor

***Danger: Operating temperature range of gear motor is: 20°C
-60°C.***

6.2.2 Clearance of the Machine

Please keep the machine clean from foreign matter, such as deposits, oil, or other materials. Do the cleanly work every day.



It is forbidden to use flammable liquids during the cleaning operation. Periodically check the status of the PU belt, and replace it, if necessary. Once the machine has been cleaned, the operator must check for worn out or damaged parts (in which case, he must replace it immediately), or for parts which are not firmly fixed (in which case, he should fix them, if this is possible).



The machine protection and safety devices must not be removed, unless a specific repair and/or maintenance action is required. These protections must be put back as soon as the reason for their removal has disappeared, in any case, they must be installed before starting the machine.



If using compressed air, the operator must wear safety glasses, and make sure that nobody is near the machine, because they may be hit by materials and dust.

6.2.3 Lubricate the Bearing

On a monthly basis lubricate the two supporters near the unloading area of the conveyor, below the protection cover, as indicated by the drawing.

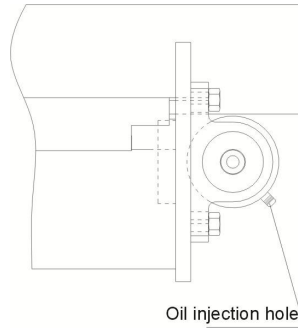

Picture 6-2: Bearing Lubricate Drawing

Stop the machine and unplug the power supply before doing the repair or maintenance work.

6.3 Maintenance Schedule

6.3.1 About the Machine

Model _____ SN _____ Manufacture date _____

Voltage _____ Φ _____ V Frequency _____ Hz Power _____ kW

6.3.2 Check After Installation

- Check if the body of the machine installed horizontal
- Check for eventual leaks of lubricant from the reduction gear
- Check the status about the PU belt

Electrical installation

- Voltage _____ V _____ Hz
- Check if the power connection of the control box is correctly

6.3.3 Daily Checking

- Check the switches of the machine.
- Check if the reduction gears is oil leaking leaking.
- Check the function of the safety switch.

6.3.4 Weekly Checking

- Check all the electrical wires.
- Check the protection function of the breaker.