

# **SBH**

## **Bridge-Breaking Hopper**

Date: Nov. 2021

Revision: Ver.B (English)





## Contents

<b>1. General Description .....</b>	<b>5</b>
1.1 Coding Principle.....	6
1.2 Features.....	6
1.3 Machine Specifications .....	8
1.3.1 External Dimensions of SBH .....	8
1.3.2 Specification List.....	8
1.4 Safety Regulations.....	9
1.4.1 Security Labels.....	9
1.4.2 Transport and Storage of Machine .....	9
1.5 Exemption Clause.....	11
<b>2. Structure Characteristics and Working Principle.....</b>	<b>12</b>
2.1 Working Description.....	12
2.1.1 Working Principle.....	12
<b>3. Installation and Debugging .....</b>	<b>13</b>
3.1 SBH installed on injection molding machine or extrusion molding machine ....	13
3.2 Installation Space.....	14
3.3 Power Supply Connection.....	14
<b>4. Application and Operation.....</b>	<b>15</b>
4.1 Control Panel .....	15
4.2 Control Panel Description .....	15
4.3 Machine Start up and Power off.....	15
4.4 Operation Method .....	16
4.5 Inverter Introduction .....	16
4.5.1 Function Indicator Description .....	16
4.5.2 Inverter Factory Set Parameter .....	17
<b>5. Trouble-shooting.....</b>	<b>18</b>
<b>6. Repair and Maintenance .....</b>	<b>19</b>
6.1 Repair .....	19
6.1.1 Motor Maintenance.....	19

6.1.2	Maintenance of Hopper and Stirring Blades .....	19
6.2	Maintenance Schedule .....	19
6.2.1	About the Machine.....	19
6.2.2	Installation & Inspection.....	19
6.2.3	Daily Checking .....	20
6.2.4	Weekly Checking.....	20

### **Table Index**

Table 1-1: Specification List.....	8
------------------------------------	---

### **Picture Index**

Picture 1-1: Outline Dimension .....	8
Picture 2-1: Working Principle.....	12
Picture 3-1: Installation Diagram.....	13
Picture 3-2: Machine Installation Requirement .....	14
Picture 4-1: Control Panel.....	15
Picture 4-2: Inverter .....	16

# 1. General Description



Please read through this operation manual before using and installation to avoid damage of the machine and personal injuries.

SBH-U bridge-breaking hopper is an auxiliary discharge device which mainly equipped on injection molding machine or extrusion molding machine. When material in large size and lightweight enter into the hopper of injection molding machine will cause material bridging and difficult discharging. SBH -160U can make the material in compulsive loading and discharging.



Model: SBH-160U

## 1.1 Coding Principle

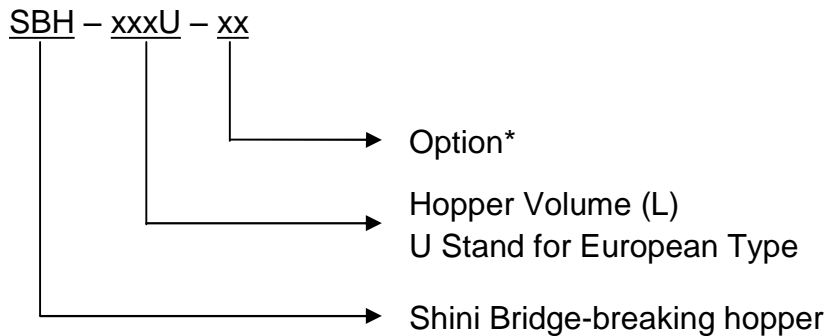

Note\*

I=Heat preservation type

P=For Polished Hopper Inside

## 1.2 Features

### Standard Configuration

- With bridge- breaking structure and screw blades welded at the end part, it can help the material go into the barrel smoothly.
- There is a supporting structure of rotating shaft inside the hopper for stable operation.
- Equipped with inverter, it allows to adjust the discharge speed according to the production demand.
- Detachable parts for the top (cover, gear motor and screw) for easy clean.
- Equipped with adapter flanges, it can work with SAL-330/360 series to realize auto feeding.
- Equipped with transitional flange,it can collocate with SAL-330/360. The loader should be of bridge-breaking design.

### Accessory Option

- Equipped with rotary material level sensor as its high material level.
- Rotary material level sensor is optional as its high material level.
- Insulation type prevents heat dissipation.

All service work should be carried out by a person with technical training or corresponding professional experience. The manual contains instructions for both handling and servicing. Chapter 6 contains service instructions which are intended for service engineers while other chapters for the daily operator.

Any modifications of the machine must be approved by SHINI in order to avoid personal injury and damage to machine. We shall not be liable for any damage caused by unauthorized change of the machine.

Our company provides excellent after-sales service. Should you have any problem during using the machine, please contact the company or the local vendor.

Shini Hotline Service:

Headquarter and Taipei factory:

Tel: + 886 (0)2 2680 9119

Shini Plastics Technologies (Dongguan), Inc.:

Tel: +86 (0)769 8331 3588

Shini Plastics Technologies (Pinghu), Inc.:

Tel: +86 (0)573 8522 5288

Shinden Precision Machinery (Chongqing), Inc.:

+86 (0)23 6431 0898

## 1.3 Machine Specifications

### 1.3.1 External Dimensions of SBH

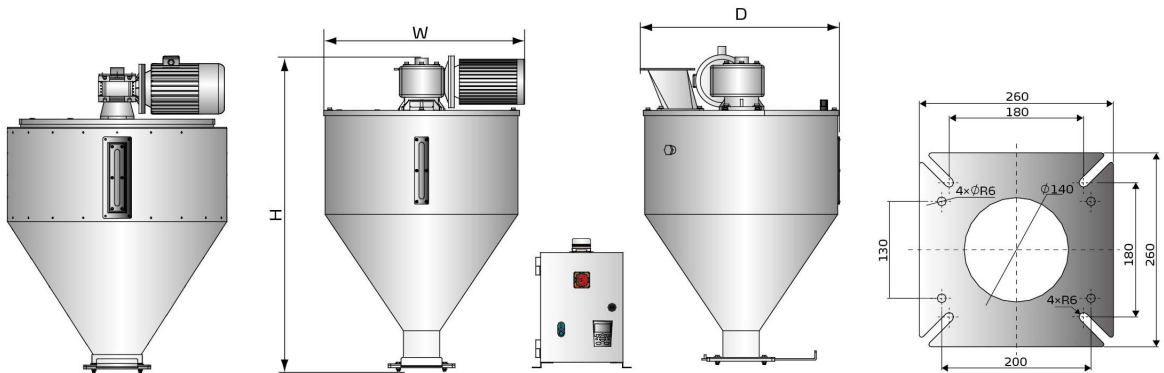

Picture 1-1: Outline Dimension

### 1.3.2 Specification List

Table 1-1: Specification List

Model	SBH-160U
Motor Power (kW)	1.5
Max. Handling Capacity (kg/hr)	5000
Mixing Barrel Volume(L)	160
External Dimension	
H(mm)	1175
W(mm)	780
D(mm)	775

Note: 1)The max. handling capacity of material is 0.3kg/L bulk density, within 30×30×0.5mm dimension measured by continuous rotating method. Data will change related to the characteristics of material.

2)For polished hopple inside, add "P" at the end of the model code.

3)Frequency arrange of motor:10-50Hz

4)Power voltage of machine: 3Φ,400V,50Hz



## 1.4 Safety Regulations

The user must conform to following safety rules when operating the machine to avoid personal injuries or machine damage.

Following regulations must be observed when operate the machine.

If key of interlocking device has lost or damaged, entire interlocking device needs replacement.

### 1.4.1 Security Labels



Installation of device is allowed only to professional electrician.

Before maintenance and repair, turn off main switch and control switch.



Warning!

High Voltage!

This label is posted on the electrical control box!



Warning!

Be careful!

Pay more attentions at the places where this sign is attached!



Warning!

If stripe material is conveyed, it may probably cause the blockage!



Attention!

No need for regular inspection because all the electrical parts in the control box are fixed tightly!

### 1.4.2 Transport and Storage of Machine

#### Transport

- 1) SBH-160U bridge-breaking hopper is packaged in crate or plywood case. The bottom with wooden plate pad which applicable for forklift prompt transport.
- 2) When in transport, don't turn on the machine to avoid it colliding with other objects and prevent abnormal operation.

- 3) Although machine has well balanced structure, it needs careful lifting to prevent dropping.
- 4) In long term transport, ambient temperature of the machine and its accessories could be  $-25^{\circ}\text{C} \sim +55^{\circ}\text{C}$ ; if in short term transport, the transport temperature could be  $+70^{\circ}\text{C}$ .

### Storage

- 1) SBH-160U should be kept indoor for storage, with environment temperature range in  $5^{\circ}\text{C} \sim 40^{\circ}\text{C}$  and humidity lower than 80%.
- 2) Cut off all the power and turn off main power switch and control switch.
- 3) In order to avoid potential failure caused by water and gas, please separate entire machine, especially the electrical components off water source.
- 4) Cover machine with plastic films to prevent dust and rain invasion.

### Working Environment

- 1) In dry indoor environment, the highest temperature should not higher than  $+45^{\circ}\text{C}$ , humidity could not exceed 80%.

### Do not use the machine:

- 1) It has damaged signs.
- 2) In order to prevent electric shock, don't operate the machine on wet floor or after rain.
- 3) If machine damaged or dismantled, without professional repair and installation.
- 4) The device could be operated in normal environment below altitude of 3000m.
- 5) At least a clearance of 1m surrounding the equipment is required during operation. Keep at least 2 meters between the device and inflammables.
- 6) Avoid vibration, magnetic disturbance at operation area.

### Rejected parts disposal

When equipment reaches its service lifespan and could not be used any more, unplug the main power and dispose it probably according to local code.

### Fire hazard



In case of fire, CO<sub>2</sub> dry powder fire extinguisher should be applied.

## 1.5 Exemption Clause

The following statements clarify the responsibilities and regulations born by any buyer or user who purchases products and accessories from Shini (including employees and agents).

Shini is exempted from liability for any costs, fees, claims and losses caused by reasons below:

1. Any careless or man-made false installation, operation and maintenance upon on machines without referring to the manual ahead machine using.
2. Any incidents beyond human reasonable controls, which include man-made vicious or deliberate damages or abnormal power, and machine faults caused by irresistible natural disasters including fire, flood, storm and earthquake.
3. Any operational actions that are not authorized by Shini upon machine, including adding or replacing accessories, dismantling, delivering or repairing.
4. Employ consumables or oil media that are not appointed by Shini.

## 2. Structure Characteristics and Working Principle

### 2.1 Working Description

SBH-160U bridge-breaking hopper working principle: the main shaft will drive the stirring shaft to stir after the signal of control box is conveyed to the stirring motor. The stainless steel part of the stirring rod's upper part will break the material and the stirring blades at the bottom will squeeze the material out of the discharge port to feed the pieces into injection molding machine.

#### 2.1.1 Working Principle

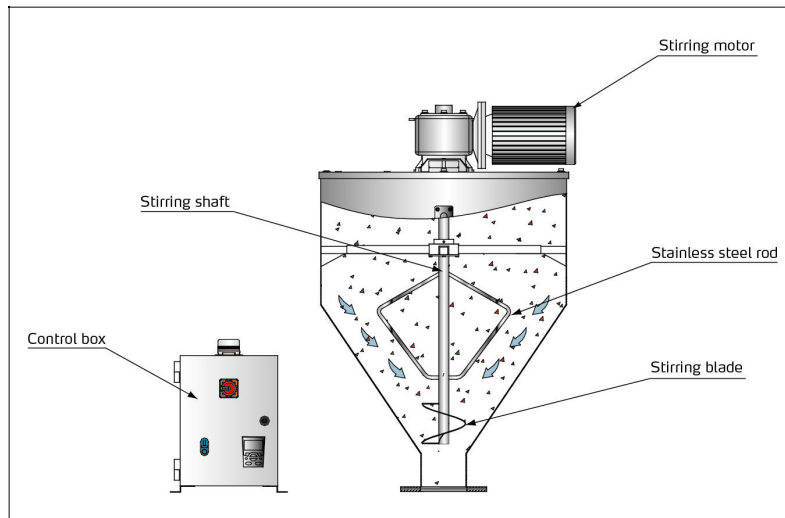

Picture 2-1: Working Principle

First, set a frequency value on the inverter according to output of the injection molding machine. Then start the machine. The main shaft will drive the stirring shaft to stir after the signal of control box is conveyed to the stirring motor (as pic.). The stainless steel part of the stirring rod's upper part will break the material and the stirring blades at the bottom will squeeze the material out of the discharge port. The frequency value can be changed according to actual output situation to reach the requirement.

### 3. Installation and Debugging

Before installation please read this chapter carefully. Orders of the installation must be observed according to following as below:



Attention! Power connection of the bridge-breaking hopper must be completed by professional electrician.

#### 3.1 SBH installed on injection molding machine or extrusion molding machine

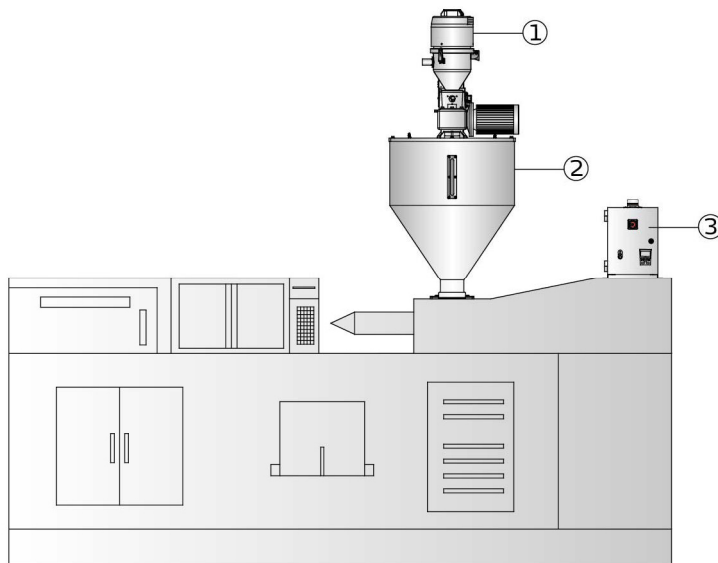

1. "Standard" Self-contained Hopper Loader 2. Bridge-Breaking Hopper 3. Control Box

Picture 3-1: Installation Diagram

SBH has simple installation which could be mounted on injection molding machine or extrusion molding machine to ensure the balance.

### 3.2 Installation Space

When machine is being installed, should keep at least 500mm space around it. (as below pic.). Don't install the machine within narrow space which crowded with other objects. In this case, repair or maintenance would be inconvenient. Don't sit on the machine. Don't place inflammables and explosives around the machine.



Picture 3-2: Machine Installation Requirement

### 3.3 Power Supply Connection

SBH control box connected with nameplate consistent power supply and ground wire. Generally, adopts 3 $\Phi$ 400VAC power supply, special customized power supply could also be used according to requirements.



Please check the rotating direction of motor after power supply is connected. If it is reversed, don't cut off the power supply. Exchange any two connecting wires of the three.

## 4. Application and Operation

### 4.1 Control Panel

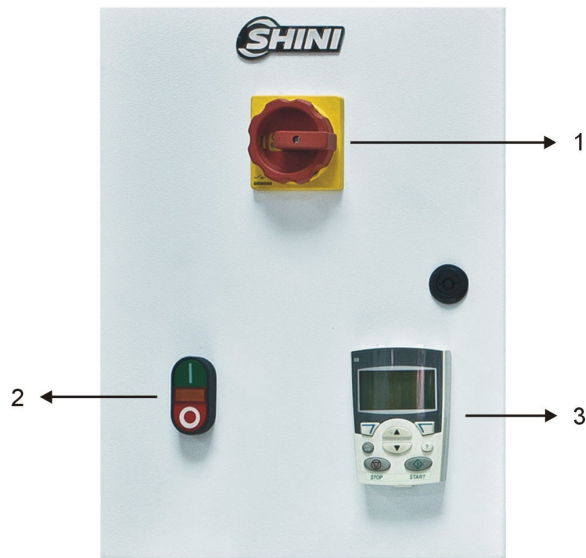

Picture 4-1: Control Panel

### 4.2 Control Panel Description

No.	Name	Function Description	Remark and Notice
1	Main power switch	Main power switch of control system	-
2	System operation	Discharging motor start/stop switch	Red button: stop; Green button: start
3	Inverter control board	Inverter parameter input	Used for inverter parameter input, and start/stop the inverter

### 4.3 Machine Start up and Power off

- 1) Check power supply .
- 2) Please turn on the main power switch of control box panel.
- 3) Please press the green button of system operation on control box panel, the motor starts rotary stirring.
- 4) When power off the machine, press the red button of system operation, then take reverse steps to turn off the power supply.

## 4.4 Operation Method

- 1) Turn on the main power switch on control box panel.
- 2) Press green button of system operation on control box panel, the motor starts rotary discharging.

## 4.5 Inverter Introduction

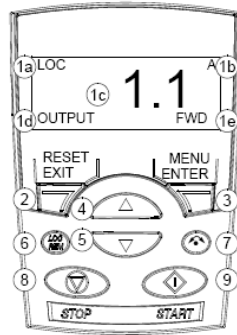

Picture 4-2: Inverter

### 4.5.1 Function Indicator Description

No.	Application
1	<p>LCD displayer – divided into 5 display areas</p> <p>top left corner—control area</p> <p>LOC: Inverter at local control mode, via control pan for controlling.</p> <p>REM: Inverter at remote control mode, via I/O terminal or profibus to control.</p> <p>Top right corner – display the unit of digit.</p> <p>Middle –variable; generally, it displays parameter and signal value, menu or list.</p> <p>It also can display the fault code of control panel.</p> <p>d, Left corner at bottom and middle—control panel working statue:</p> <p>OUTPUT: Output mode</p> <p>PAR: Parameter mode</p> <p>MENU: Main menu</p> <p>e. Right corner at bottom—statue displayer:</p> <p>FWD ( forward) /REV ( reverse): motor rotary direction</p> <p>Slow flicker: already stop</p> <p>Quick flicker: motor is running but not at set point;</p> <p>Stable: running at set point;</p> <p>Setting: display value could be modified (in parameter and set value mode).</p>
2	<p>RESET/EXIT – withdraw to up menu, and don't save the modification. Under output and failure mode to get failure reset.</p>
3	<p>MENU/ENTER – enter into next menu. Under parameter mode, save the displayed value as new set value.</p>
4	<p>– Upward</p> <ul style="list-style-type: none"> <li>• Rolling the menu or list upward.</li> </ul>



	<ul style="list-style-type: none"> <li>• If a parameter is chosen, add the value of the parameter.</li> <li>• Under set value mode to add to the set value.</li> </ul> Press the key and not loosen it could get prompt modification.
No.	Application
5	– Downward <ul style="list-style-type: none"> <li>• Rolling the menu or list downward.</li> <li>• If a parameter is chosen, lessen the value of the parameter.</li> <li>• Under set value mode to lessen the set value.</li> </ul> Press the key and not loosen it could get prompt modification.
6	LOC/REM –Switch between the local mode and remote mode
7	DIR – Change motor rotary direction.
8	STOP –Under local mode, stop the inverter.
9	START – Under local mode, start up the inverter.

#### 4.5.2 Inverter Factory Set Parameter

No.	Parameter Code	Parameter Meaning	Factory Set Value	Remark
1	1001	Digit input for start/stop control	1	-
2	1003	Forward	1	-
3	1103	Control panel has external source signal.	0	-
4	1401	Failure output	4	-
5	2007	Min. frequency	10	-
6	2008	Max. frequency	50	-
7	2202	Speed up time	5	-
8	2203	Speed reduced time	3	-
9	9901	Language switch	0 English /1 Chinese	-

Following parameters are set according to motor's nameplate

9905 (motor voltage) 9906 (motor current) 9907 (motor frequency)

9908 (motor rotary speed) 9909 (motor power)



Attention!

LOC/ corresponding manual control function on inverter panel.

REM on inverter panel is corresponding to linkage function of extruder. When linkage works, 0~10V signal of extruder is connected to control inverter 2-3 point of bridge-breaking hopper.

## 5. Trouble-shooting

Failures	Possible reasons
Power supply connected, rotate switch of main power supply, press control button, the light don't turn on, motor don't rotate,	Check the circuit according to circuit diagram, possible reasons are: 1. Circuit has break. 2. Fuse burnt. If motor rotate but light don' t turn on, means the light is broken. If light turned on, but motor don' t rotate, means motor or inverter has problem.
When motor is running, press stop button, it dosen't work.	Stop button is broken, the contact end maybe burnt, it could be replaced.

## 6. Repair and Maintenance

### 6.1 Repair

All the repairs must be completed by professionals to avoid damage of the machine and personal injury.

#### 6.1.1 Motor Maintenance

Please pay attention to keep the stirring motor and gear box clean. Remove the dust, pollutant in time to make easy heat dissipation.

#### 6.1.2 Maintenance of Hopper and Stirring Blades

Open the hopper lid, spray-blow the residual material in the hopper with air gun, then use soft cloth to wipe the hopper inside and the stirring blades clean.



Attention!

Before machine repair and maintenance, must turn off the main switch and the control switch.

### 6.2 Maintenance Schedule

#### 6.2.1 About the Machine

Model \_\_\_\_\_ SN \_\_\_\_\_ Manufacture Date \_\_\_\_\_

Voltage \_\_\_\_\_  $\Phi$  \_\_\_\_\_ V Frequency \_\_\_\_\_ Hz Power \_\_\_\_\_ kW

#### 6.2.2 Installation & Inspection

- Check if the machine horizontal installation.
- Check the motor installation.

##### Electrical Installation

- Volatge: \_\_\_\_\_ V \_\_\_\_\_ Hz
- Fuse melt current: 1 $\Phi$  \_\_\_\_\_ A 3 $\Phi$  \_\_\_\_\_ A
- Check the control box power supply connection.

### 6.2.3 Daily Checking

- Check main power supply switch.
- Check system operation button.

### 6.2.4 Weekly Checking

- Check all the electrical cables.
- Check motor overload relay and anti-phase function.