

SG-1628D

Low-speed Granulator

Date: Oct, 2014

Version: Ver.A (English)



Contents

1. General Description	8
1.1 Coding Principle	9
1.2 Feature	9
1.3 Technical Specifications	11
1.3.1 Technical Specifications.....	11
1.3.2 Dimensions	12
1.4 Safety Regulations	13
1.4.1 Safety Signs and Labels	13
1.4.2 Transportation and Storage of the Machine	15
1.5 Exemption Clause	17
2. Structural Features and Working Principle	18
2.1 General Description.....	18
2.1.1 Working Principle	18
2.2 Safety System	19
2.2.1 Emergency Stop Switch	19
2.2.2 Safety System.....	20
2.2.3 Hexagon Screw.....	20
2.3 Assembly Drawing.....	21
2.3.1 Assembly Drawing	21
2.3.2 Parts List	22
2.3.3 Cutting chamber.....	23
2.3.4 Cutting chamber parts list	23
2.3.5 Feed box parts	25
2.3.6 Feed box parts list.....	25
2.3.7 Screen bracket parts	26
2.3.8 Assembly of screen bracket list.....	26
2.3.9 Storage box parts.....	27
2.3.10 Storage box parts list	27
2.3.11 Control box parts.....	28
2.3.12 Control box parts list	28
2.4 Electrical Diagram	29

2.4.1	Main Circuit (400V)	29
2.4.2	Control Circuit (400V)	30
2.4.3	Components Layout (400V)	31
2.4.4	Electrical Components List (400V)	32
2.4.5	Main Circuit (230V)	33
2.4.6	Control Circuit (230V)	34
2.4.7	Components Layout (230V)	35
2.4.8	Electrical Components List (230V)	36
2.5	Electrical Components Description	37
2.6	Optional Accessories	38
2.6.1	Screen	38
2.6.2	Blade Selection	38
2.6.3	30 Seconds Instant recycling system	38
3.	Installation and Debugging	44
3.1	Installation Notice	45
3.2	Installation Place	46
3.3	The installation of cutting chamber	47
3.4	Installation of Rotating Blade and fixed Blade	47
3.5	Installation of Feed Box and Feed Port	48
3.6	Installation of Material Collection Box	50
4.	Operation Guide	52
4.1	Startup Pretest	52
4.1.1	Before the First Startup	52
4.1.2	After First Startup for 2 Hours	52
4.1.3	After First Startup for 20~30 Hours	错误! 未定义书签。
4.2	Circuit Connection	53
4.3	Open the Feed Box and Storage Box	53
4.3.1	Open the Feed Box	53
4.3.2	Open the Storage Box	54
4.3.3	Open the Screen and Screen Frame	54
4.4	Shut Up the Feed Box and Storage Box	55
4.4.1	Close the Feed Box	55
4.4.2	Shut up the Storage Box	55
4.5	Start and Stop the Granulator	56

5. Trouble-shooting	58
5.1 Granulator Can Not Work	58
5.2 Stop Due to Other Reasons.....	59
6. Maintenance and Repair	60
6.1 Repair	60
6.1.1 Blades Structure in Cutting Chamber	61
6.1.2 Replace the Blades	61
6.2 Maintenance	63
6.2.1 Daily check.....	64
6.2.2 Weekly Check	64
6.3 Cleaning	64
6.4 Maintenance Schedule	66
6.4.1 About the Machine	66
6.4.2 Check After Installation	66
6.4.3 Daily Check.....	66
6.4.4 Weekly Check	66
6.4.5 Monthly Check	66
6.4.6 Check Half-yearly or Every 1000 Running Hours.....	67
6.4.7 3 year Checking	67

Table index

Table 1-1: Technical Specifications	11
Table 2-1: Parts List	22
Table 2-2: Cutting chamber parts list.....	23
Table 2-3: Feed box parts list	25
Table 2-4: Assembly of screen bracket list	26
Table 2-5: Storage box parts list.....	27
Table 2-6: Control box parts list.....	28
Table 2-7: Electrical Components List (400V)	32
Table 2-8: Electrical Components List (230V).....	36

Picture index

Picture 1-1: Dimensions	12
Picture 2-1: Working Principle	18
Picture 2-2: Safety Switch	19
Picture 2-3: Emergency Stop Switch	19
Picture 2-4: Safety System.....	20
Picture 2-5: Assembly Drawing	21
Picture 2-6: Cutting chamber	23
Picture 2-7: Feed box parts	25
Picture 2-8: Screen bracket parts	26
Picture 2-9: Storage box parts	27
Picture 2-10: Control box parts.....	28
Picture 2-11: Main Circuit (400V).....	29
Picture 2-12: Main Circuit (230V).....	33
Picture 2-13: Control Circuit (230V).....	34
Picture 2-14: Components Layout (230V)	35
Picture 2-15: Electrical Components Description.....	37
Picture 2-16: 30 Seconds Instant recycling system	38
Picture 2-17: Dust separating System	43
Picture 3-1: Installation Space	45
Picture 3-2: Installation Place	46
Picture 3-3: The installation of cutting chamber.....	47
Picture 3-4: Installation of Rotating Blade and fixed Blade 1.....	47
Picture 3-5: Installation of Rotating Blade and fixed Blade 2.....	47
Picture 3-6: Installation of Rotating Blade and fixed Blade 3.....	48
Picture 3-7: Installation of Rotating Blade and fixed Blade 4.....	48
Picture 3-20: Installation of Feed Box and Feed Port 1	48
Picture 3-21: Installation of Feed Box and Feed Port 2.....	49
Picture 4-1: Open the Feed Box	54
Picture 4-2: Open the Storage Box	54
Picture 4-3: Open the Screen and Screen Frame 1	54
Picture 4-4: Open the Screen and Screen Frame 2	55
Picture 4-5: Close the feed box.....	55
Picture 4-6: Shut up the Screen and Screen Frame.....	56
Picture 4-7: Main Power Switch	56

Picture 4-8: Stop, Emergency Stop and Startup button.....	57
Picture 6-1: Blades Structure in Cutting Chamber	61
Picture 6-2: Rotating Blades Sharpening.....	61
Picture 6-3: Maintain and Clean Blades	62
Picture 6-4: Star Screw.....	64
Picture 6-5: Clearing the Dust Collection Chambers	65

1. General Description



Please read this manual carefully before using this machine in order to operate correctly against any damage caused due to improper operation.



Note!

Always take great care when the knives are within reach, they are very sharp and can cause personal injury.



Forbidden to process flammable or toxic material!

SG-1628D series low-speed granulator is suitable for crushing sprue materials and a few of rejects. It is set on the side of Plastics Molding Machines and Picker, collocated with belt conveyor. It features low speed, big driving torque, low noise, low dust level and simple operation.



Model: SG-1628D

1.1 Coding Principle

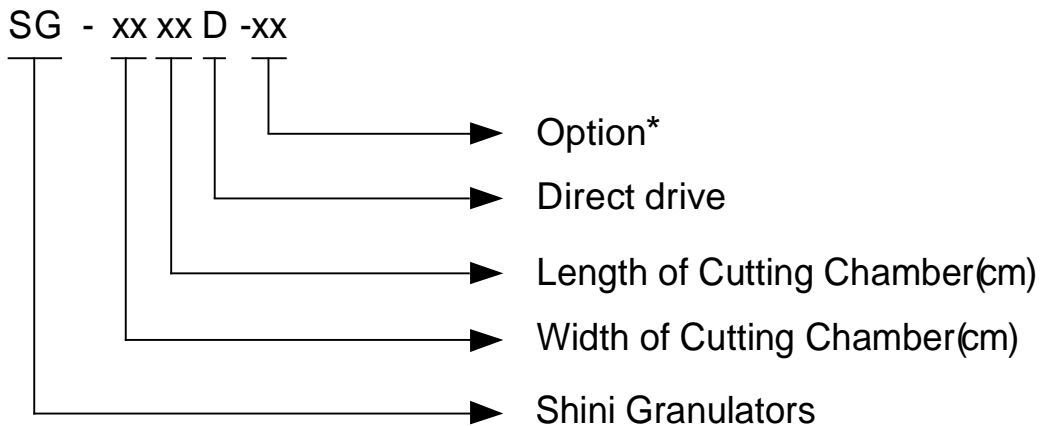

Note:*

VR=Loading by High Pressure Air BR=Loading by Bolwer

CE=CE Conformity

1.2 Feature

1) Standard Configuration

- SG-1628D series adopt new type staggered blades and unfixed blades which can keep a settled cutting clearance without adjustment after resharpen; SG-20N employs paddle blades and integration design to obtain better cutting performance.
- Low granulating speed and sharp angle design of rotating blades are helpful for smooth and continuous operation.
- Gear motor drives cutter shaft rotating directly for smashing, it saves maintenance time of belt tension adjustment by belt rotation.
- Storage box around design with external cutting chamber to avoid regrind material leakage effectively.
- Optimized cutting angle makes resistance small and avoid blockage to improve cutting efficiency.
- Optimum design can effectively reduce vibration during granulator operation.
- Low speed granulating ensures well-proportioned granules and low dust level.
- Low speed and sound-proof material hopper brings a quieter operation environment.
- Easy access to easy maintenance and cleaning.

- Small in size with castors for easy moving.
- High safety grade design to comply with European safety standard.
- Built-in magnet installed at the inlet of the feeding chamber, metal impurities in the materials can be avoided.

2) Accessory option

- 30-sec instant recycling system, regrinds conveying via blower & cyclone, dust separator and full-receiver alarm device.
- Special screens.

All service work should be carried out by a person with technical training or corresponding professional experience. The manual contains instructions for both handling and servicing. Chapter 6, which contains service instructions intended for service engineers. Other chapters contain instructions for the daily operator.

Any modifications of the machine must be approved by SHINI in order to avoid personal injury and damage to machine. We shall not be liable for any damage caused by unauthorized change of the machine.

Our company provides excellent after-sales service. Should you have any problem during using the machine, please contact the company or the local vendor.

Headquarter and Taipei factory: Shini Plastics Technologies (Dongguan), Inc:
Tel: (886) 2 2680 9119 Tel: (86) 769 8111 6600

Shini Plastics Technologies India Pvt.Ltd.:
Tel: (91) 250 3021 166

1.3 Technical Specifications

1.3.1 Technical Specifications

Table 1 1: Technical Specifications

Model	SG-1628D
Motor Power (kW, 50/60Hz)	2.2
Main Shaft Rotating Speed (rpm, 50/60Hz)	220
Material of Blades	SKD11
Type of Blades	Staggered
Number of Fixed Blades	2×1
Number of Rotating Blades	12
Cutting Chamber Dimension (mm)	160×280
Max. Throughput Capacity (kg/hr)	50
Noise Level dB(A)	85~90
Dia. of Screen Mesh (mm)	✓(Φ5)
Dimensions	
H (mm)	1180
W (mm)	920
W1 (mm)	365
D (mm)	620
D1 (mm)	330
Weight (kg)	195

We reserve the right to change specifications without prior notice.

Note: 1) "-/"/ standard.

- 2) Max. capacity of the machine is subject to diameter of screen hole and composition of the material.
- 3) Noise level will vary with different materials and motor types.
- 4) For avoiding plastic to adhibit the blade, all materials should be crushed at normal temperature.
- 5) Power supply: 3Φ, 400VAC, 50Hz

1.3.2 Dimensions

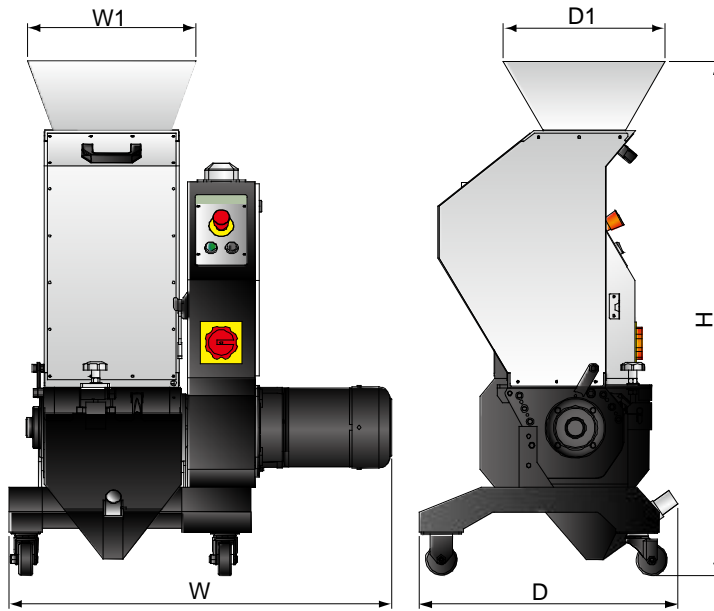

Picture 1-1: Dimensions

1.4 Safety Regulations

Follow the instructions in this manual to avoid personal injury and damage to machine components.

1.4.1 Safety Signs and Labels



Electrical installation must only be done by a competent electrician!



Before the granulator is opened for servicing and maintenance, always disconnect the power with both the main switch and the control switch of the granulator.



Never put any part of your body through the granulator openings, unless both the main switch and the control switch of the granulator are in "Off" position.



High voltage! Danger!

This sign is attached on the control box and the wiring box.



Be careful the rotating knives, they are very sharp and may cause personal injury!



Be careful the rotating knives by human person, they are very sharp and may cause injury!



Don't start the granulator before the feed box and suction box are properly closed.



Attention please!

Ear protection is essential during the granulating of plastic materials.



Attention!

No need for regular inspection because all the electrical parts in the control unit are fixed tightly!



Make sure the power has been cut off before opening the feed box.



Loading blower is applicable to convey regrind and powder, and it requires that the temperature of regrind and powder should not be high than 80°C.









The loading blower has great suction power and it is easy to get things or clothes sucked into, so the blower should have a protective cover.



Please clean the dust of air from air inlet regularly.

When operate the granulator, please notice the following signs

<div style="border: 1px solid black; padding: 5px;"> <p style="text-align: center;">Maintenance Schedule</p> <table border="1" style="width: 100%; border-collapse: collapse;"> <thead> <tr> <th style="text-align: center;">Item</th> <th style="text-align: center;">CT</th> </tr> </thead> <tbody> <tr> <td>Check the temperature controller.</td> <td>Daily</td> </tr> <tr> <td>Clean the filter.</td> <td>Daily</td> </tr> <tr> <td>Check whether overheat protection is normal.</td> <td>Daily</td> </tr> <tr> <td>Check whether dew-point is normal.</td> <td>Daily</td> </tr> <tr> <td>Check whether the contactor is normal.</td> <td>Yearly</td> </tr> <tr> <td>Check whether air pipe is shed, leaked and loose</td> <td>Weekly</td> </tr> <tr> <td>Check whether cooling water circulation and Y-type filter are normal.</td> <td>Daily</td> </tr> <tr> <td>Check whether honey-comb rotor belt is damaged.</td> <td>Semi-yearly</td> </tr> <tr> <td>Clean the cooler.</td> <td>Semi-yearly</td> </tr> <tr> <td>PCB renewal.</td> <td>Every 3 year exchange</td> </tr> <tr> <td>No fuse breaker.</td> <td>Every 3 year exchange</td> </tr> </tbody> </table> <p style="font-size: small; margin-top: 5px;">Note: Please refer to the Manual for detailed operations. 7P3115860103</p> </div>	Item	CT	Check the temperature controller.	Daily	Clean the filter.	Daily	Check whether overheat protection is normal.	Daily	Check whether dew-point is normal.	Daily	Check whether the contactor is normal.	Yearly	Check whether air pipe is shed, leaked and loose	Weekly	Check whether cooling water circulation and Y-type filter are normal.	Daily	Check whether honey-comb rotor belt is damaged.	Semi-yearly	Clean the cooler.	Semi-yearly	PCB renewal.	Every 3 year exchange	No fuse breaker.	Every 3 year exchange	<p>Please follow the cycle to keep maintenance regularly.</p>
Item	CT																								
Check the temperature controller.	Daily																								
Clean the filter.	Daily																								
Check whether overheat protection is normal.	Daily																								
Check whether dew-point is normal.	Daily																								
Check whether the contactor is normal.	Yearly																								
Check whether air pipe is shed, leaked and loose	Weekly																								
Check whether cooling water circulation and Y-type filter are normal.	Daily																								
Check whether honey-comb rotor belt is damaged.	Semi-yearly																								
Clean the cooler.	Semi-yearly																								
PCB renewal.	Every 3 year exchange																								
No fuse breaker.	Every 3 year exchange																								
	<div style="text-align: center;"> <p>Danger!</p> </div> <p>High voltage! May lead to casualty or other serious danger. Please cut off the power before repairing. Circuit diagram should only be changed by professionals. Grounding is necessary before power supply turned on.</p>																								

	 <p>Warning! There is a pinch risk for this protective cover keep some distance away from it</p>
	 <p>Warning! The cutter are very sharp, may cause injury. The protective cover is not allowed to take out or open when machine is running. Keep some distance away from the cutters.</p>
	 <p>Notice ! Read the instruction manual carefully before operation. Before start, test the safety device according to the instruction. It is not allowed to change the design of the machine unless it is approved by the manufacturer.</p>

1.4.2 Machine Transportation, Storage and Working Environment

Transportation

- 1) SG-1628D series of granulator are packed in plywood cases with wooden pallet at the bottom, suitable for quick positioning by fork lift.
- 2) After unpacked, castors located at the bottom of the machine can be used for easier movement.
- 3) Don't rotate the machine and avoid collision with other objects during transportation to prevent abnormal operation.
- 4) Although the structure of machine is well-balanced and has device for transportation, it should also be handled with care when lifting the machine to prevent falling down.
- 5) The machine and its accessories can be kept at a temperature from -25°C to +55°C for long distance transportation. For a short distance, it can be transported with temperature under +70°C.

Storage

- 1) SG-1628D series granulator should be stored indoors under temperature kept from 5°C to 40°C and humidity below 80%.

- 2) Disconnect all power supply and turn off main switch and control switch.
- 3) Keep the whole machine, especially the electrical components away from water to avoid potential troubles caused by the water.
- 4) Plastic film should be used to protect the machine from dust and rains.

Working Environment

The machine should be operated: Indoors in a dry environment with max. temperature under +45°C and humidity no more than 80%.

Do not use the machine as following circumstance:



- 1) If it is with a damaged cord.
- 2) On a wet floor or when it is exposed to rain to avoid electrical shock.
- 3) Without repairing and installation by professional technician, the machine has been damaged or dismantled.
- 4) This equipment works normally in the environment under altitude of 3000m.
- 5) At least 1m surrounding clearance of the equipment during operation.
Keep this equipment away from flammable sources at least 2m.
- 6) Avoid vibration, magnetic disturbance at operation area.

Rejected Parts Disposal

When the equipment reaches its service life and can not be used any more, unplug the power supply and dispose it properly according to local code.



Fire hazard

In case of fire, CO₂ dry powder fire extinguisher should be equipped.



Flammable and explosive materials or materials which are contaminated by flammable substances/liquid mustn't be processed in the granulator. It may cause serious risk of fire or explosion.



It is very important to tighten the screw according to required torque.



When material width is bigger than material inlet, please cut the material until its length is less than the diameter of material inlet.



Please don't put materials into the granulator if they are thinner than 2mm and are soft as well as flexible materials, like rubber.

1.5 Exemption Clause

The following statements clarify the responsibilities and regulations born by any buyer or user who purchases products and accessories from Shini (including employees and agents).

Shini is exempted from liability for any costs, fees, claims and losses caused by reasons below:

1. Any careless or man-made installations, operation and maintenances upon machines without referring to the Manual prior for machine using.
2. Any incidents beyond human reasonable controls, which include man-made vicious or deliberate damages or abnormal power, and machine faults caused by irresistible natural disasters including fire, flood, storm and earthquake.
3. Any operational actions that are not authorized by Shini upon machine, including adding or replacing accessories, dismantling, delivering or repairing.
4. Employing consumables or oil media that are not appointed by Shini.

2. Structural Features and Working Principle

2.1 Function Description

Granulator of SG-1628D series is designed for grinding different types of plastic wastes. The granulator is controlled by main power switch, emergency stop button, safety switch, start and stop button.

2.1.1 Working Principle

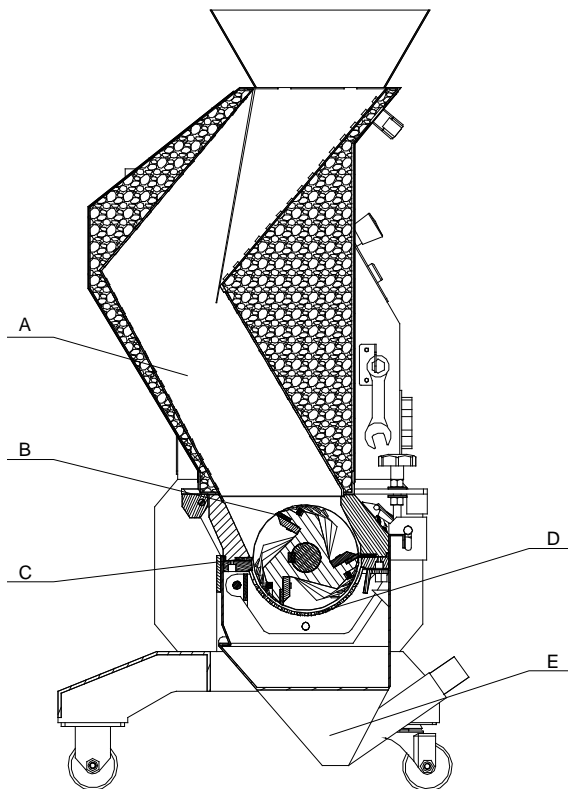

Parts name:

A. Feed box B. Rotating blade C. Fixed blade D. Screen E. Storage box

Picture 2-1: Working Principle

The materials are fed via feed box (A) and falls down to the rotating blades (B) there it grinds the materials against the fixed blades (C) in the cutting chamber. Underneath there is a screen (D) which the granulate passes through before it is gathered in the storage box (E). The storage box, screen and screen frame

are removable. The feed box can also be opened up for easy cleaning and maintenance.

2.2 Safety System

To avoid accidental human injury during granulator running, a set of safety system has been designed. In any cases, the safety system cannot be changed at random. Otherwise the machine will be under dangerous condition and lead to accident happening. The maintenance and preservation of safety system shall be done by professional staff. In case the safety system of granulator is changed, our company will not perform our commitment. The replacement of all spare parts will be done by SHINI Company.



Picture 2-2: Safety Switch

2.2.1 Emergency Stop Switch

There is one red button on the control panel. By pushing it, the machine will stop running. Turn the button as the arrow direction shown on the button, the button will reset (counter-clockwise).

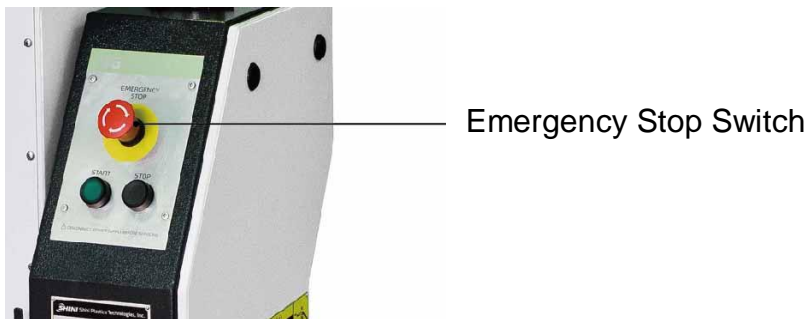

Picture 2-3: Emergency Stop Switch

2.2.2 Safety System

On the granulator is equipped with the safety position switch for the breaker. In case the position of storage box or feed box is changed or the breaker is loosened, it will cut off the power supply.

There is one safety switch on the granulator locating between the feed box and the storage box.



Picture 2-4: Safety System

2.2.3 Hexagon Screw

When opening the feed box and cutting chamber, a long hexagon screw should be loosed (it's just the door lock). It will take a long time to loosen the screw. And this period of time is enough to stop the blade bearing completely which can avoid human injury.

Before the machine switch-on, please notice:

Check if the hexagon screw on feed box and storage box has been locked tightly or not.

2.3 Assembly Drawing

2.3.1 Assembly Drawing

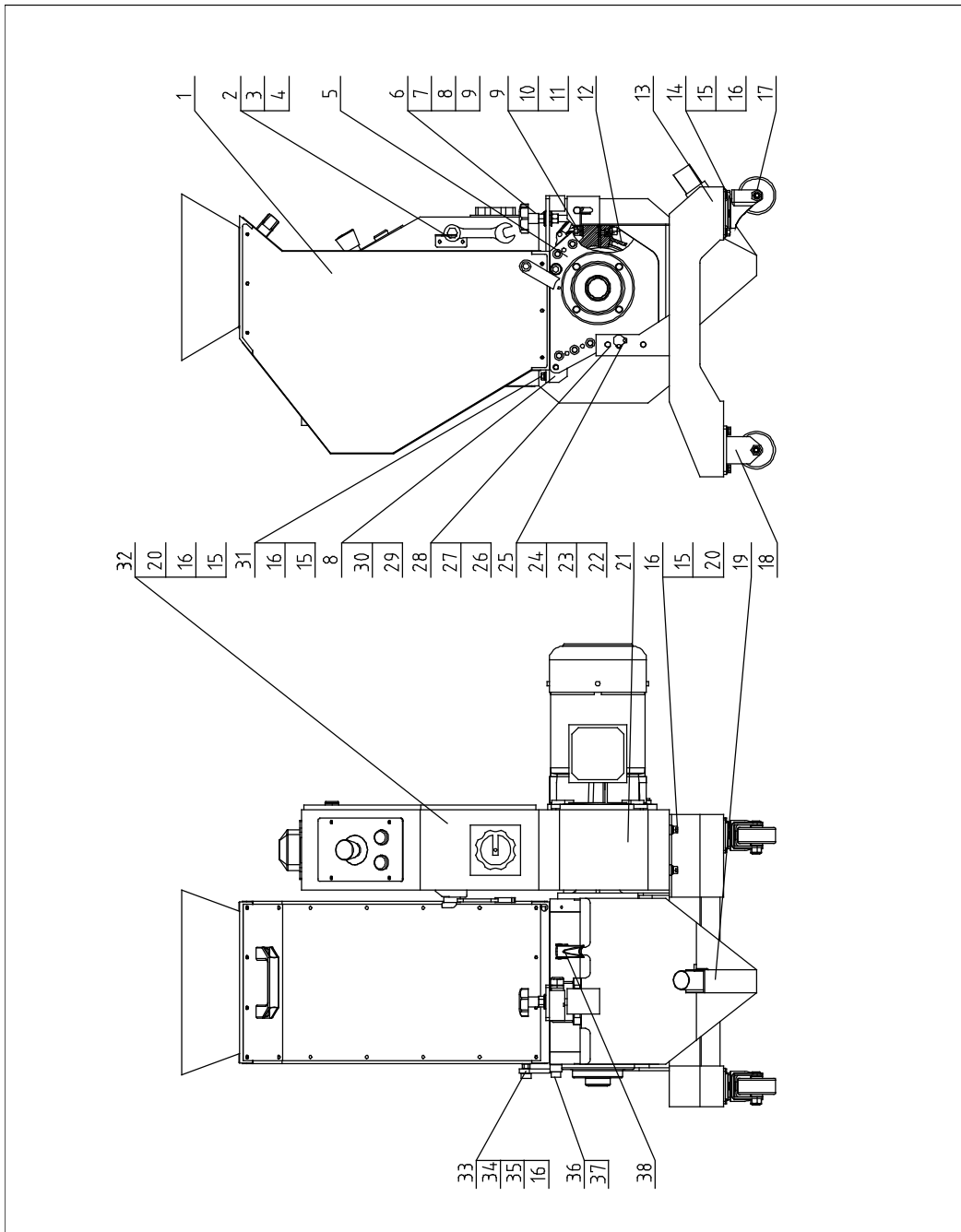

Note: Please refer to 2.3.2 material list about the parts code.

Picture 2-5: Assembly Drawing

2.3.2 Parts List

Table 2-1: Parts List

No.	Name	Part No.	No.	Name	Part No.
1	Feed box parts	-	20	Inner hexagon screw M8x20	YW61082000 200
2	Wrench hook	-	21	Control box bracket	-
3	Cross recessed pan head screw M5x10	YW62051000100	22	Cover plate	-
4	Short ratchet spanner	JT10001806000	23	Screen bracket shaft pin	BH10162801 910
5	Cutting chamber	BH85162800950	24	Hex socket screw M5x8	YW61050800 000
6	Feed box star assembly	BH10204208510	25	Spring washer 5	YW65050000 000
7	Screw locknut	BH11241000010	26	Inner hexagon screw M10x30	YW61103000 100
8	Inner hexagon set screw M5x5	YW68005500000	27	Spring washer 10	YW65010000 000
9	Flat gasket 12	YW66122400000	28	Flat gasket 10	YW66102000 100
10	Inner hexagon screw M12x80	YW61128000000	29	Rotary shaft base	BH10160300 910
11	Spring washer 12	YW65012000000	30	Rotary shaft base insert rod	BH10160400 910
12	Component of screen bracket	-	31	Hexagon screw bolt M8x25	YW60082500 200
13	Rack	-	32	storage box parts	-
14	Hexagon screw bolt M8x16	YW60081600100	33	Limit block	-
15	Spring washer 8	YW65008000200	34	Inner hexagon screw M8x25	YW61082500 100
16	Flat gasket 8	YW66081600000	35	Hexagonal nut M8	YW64080600 000
17	castor with brake 3"	YW03000300000	36	Limit block sleeve	BH10162804 110
18	fixed castor 3"	YW03000300300	37	Inner hexagon screw M10x25	YW61102500 000
19	storage box parts	-	38	Snap hook	YW02003000 400

Please confirm the version of manual before placing the purchase order to guarantee that the item number of the spare part is in accordance with the real object.

2.3.3 Cutting Chamber

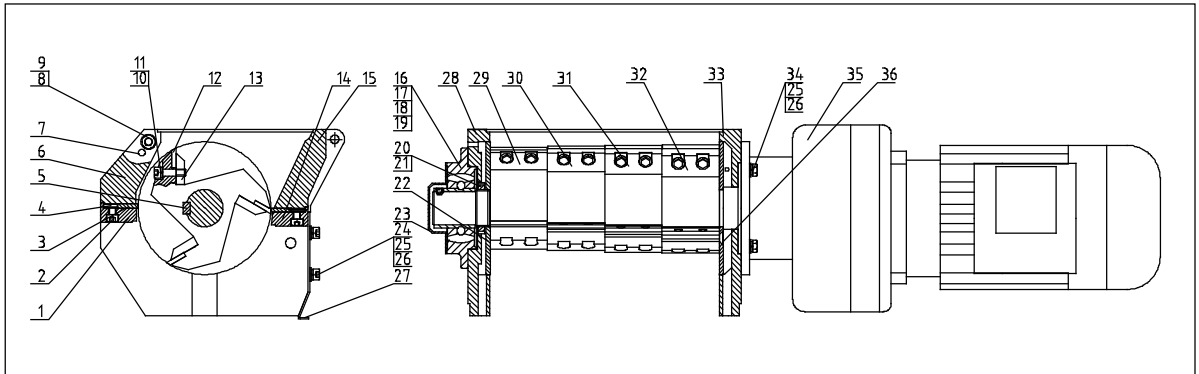

Picture 2-6: Cutting Chamber

2.3.4 Cutting Chamber Parts List

Table 2-2: Cutting Chamber Parts List

No.	Name	Number of.	Part No.
1	Pressure block of front block	1	BH10162804010
2	Inner hexagon screw M8x25**	6	YW61082500100
3	Fixed blade**	2	YW41162820000
4	Inner hexagon set screw M5 x16	4	YW68051600000
5	Flat key 14x9x272	1	BH10091400010
6	Front block	1	BW30162806110
7	Elastic column pin 8x35	8	YW69083500000
8	Inner hexagon screw M10x30	12	YW61103000100
9	Spring washer10	12	YW65010000000
10	Inner hexagon screw M8x30	24	YW61083000000
11	Spring washe8**	24	YW65008000200
12	Rotating blade**	12	YW42162840000
13	Lock blade for rotating blade**	12	BH11162700010
14	Pressure block of back block	1	BH10160280010
15	Back block	1	BH10162900010
16	Bearing with base UCFC208	1	YW11020800000
17	Inner hexagon screw M12x45	4	YW60124500000
18	Spring washer 12	4	YW65012200000
19	Flat gasket 12	4	YW66122400000
20	Small round nut M45x1.5	1	YW64451500000

21	Stop washer for round nut 45	1	YW09004500000
22	Material fender	2	BH1016051210
23	Bearing cover	1	-
24	Inner hexagon screw M8x16	4	YW61081600000
25	Spring washe 8	8	YW65008000200
26	Flat gasket 8	8	YW66081600000
27	Suction box connection plate	1	-
28	Left bearing holder	1	BH10160700910
29	Blade rest 1	1	BH10160100910
30	Blade rest 2	1	BH10160200910
31	Blade rest 3	1	BH10160300910
32	Blade rest 4	1	BH10160400910
33	Right bearing holder	1	BH10160600910
34	Hexagon screw bolt M8x30	4	YW60083000000
35	Gear box	1	YM50162800100
36	Flat head inner hexagon screw M8x16	6	YW61081600100

* means possible broken parts. ** means easy broken part. and spare backup is suggested.
Please confirm the version of manual before placing the purchase order to guarantee that the item number of the spare part is in accordance with the real object.

2.3.5 Feed Box parts

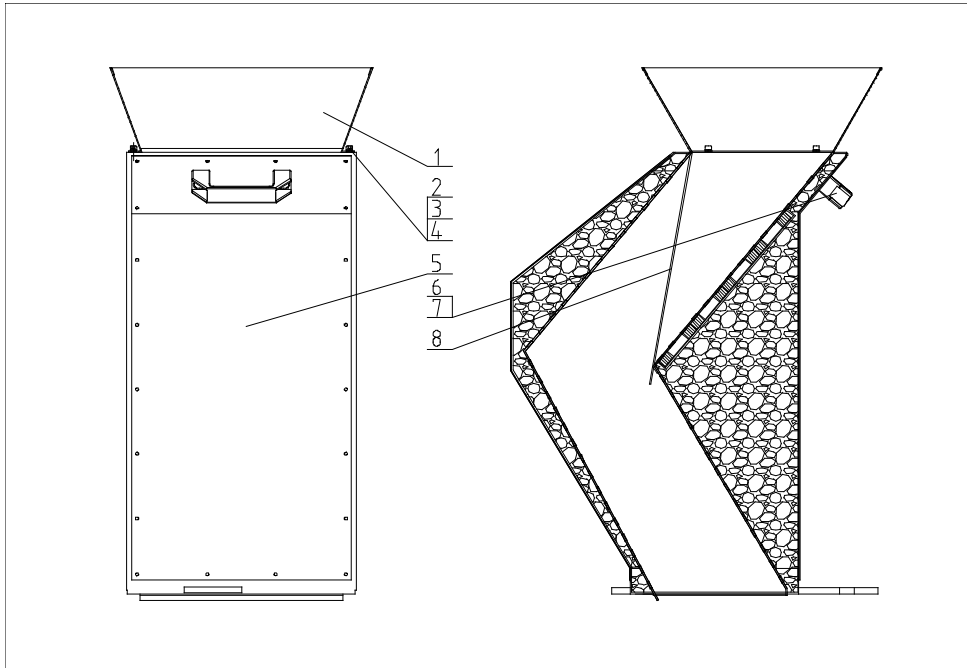

Picture 2-7: Feed Box Parts

2.3.6 Feed Box Parts List

Table 2-3: Feed Box Parts List

No.	Name	Number of.	Part No.
1	Material inlet	1	-
2	Inner hexagon screw M5x10	4	YW61051000000
3	Spring washe 5	4	YW65005200000
4	Flat gasket 5	4	YW66051000000
5	Feed box	1	-
6	Handle L120	1	BW20012000140
7	Inner hexagon screw M8x16	2	YW61081600000
8	Material keeping rubber	1	-

2.3.7 Screen Bracket Parts

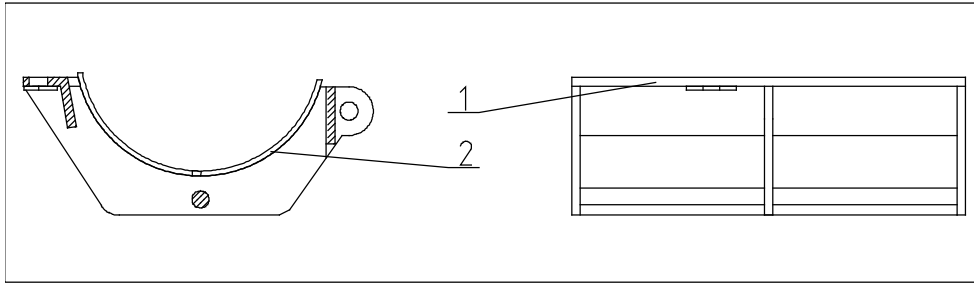

Picture 2-8: Screen Bracket Parts

2.3.8 Assembly of screen bracket list

Table 2-4: Assembly of Screen Bracket List

No.	Name	Number of.	Part No.
1	Screen bracket	1	-
2	screenφ5	1	BL50162860020

2.3.9 Storage Box Parts

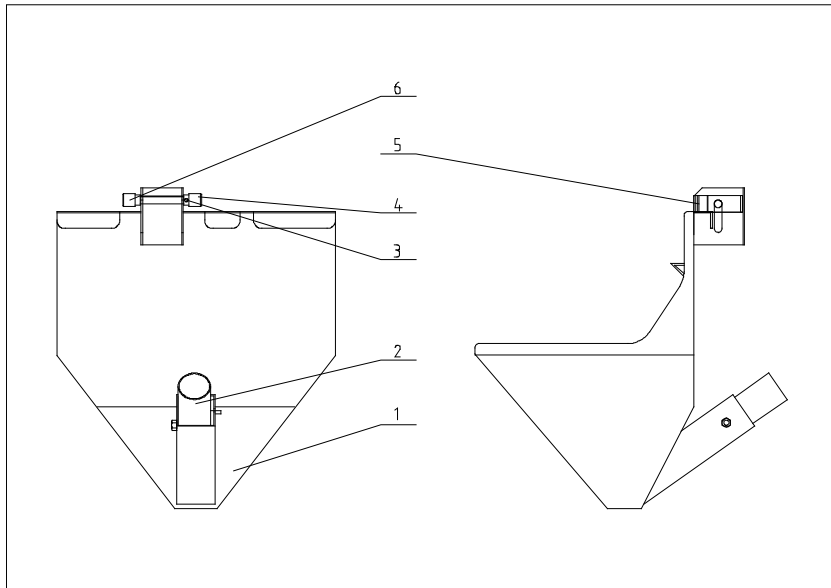

Picture 2-9: Storage Box Parts

2.3.10 Storage Box Parts List

Table 2-5: Storage Box Parts List

No.	Name	Number of.	Part No.
1	Storage box	1	-
2	Suction pipe	1	BL50202801120
3	Inner hexagon set screw M4x5	1	YW68004500000
4	Safety switch knob	1	BH10024200010
5	Safety switch mounting plate	1	BH10204202310
6	Safety switch mounting shaft	1	BH10204300010

2.3.11 Control Box Parts

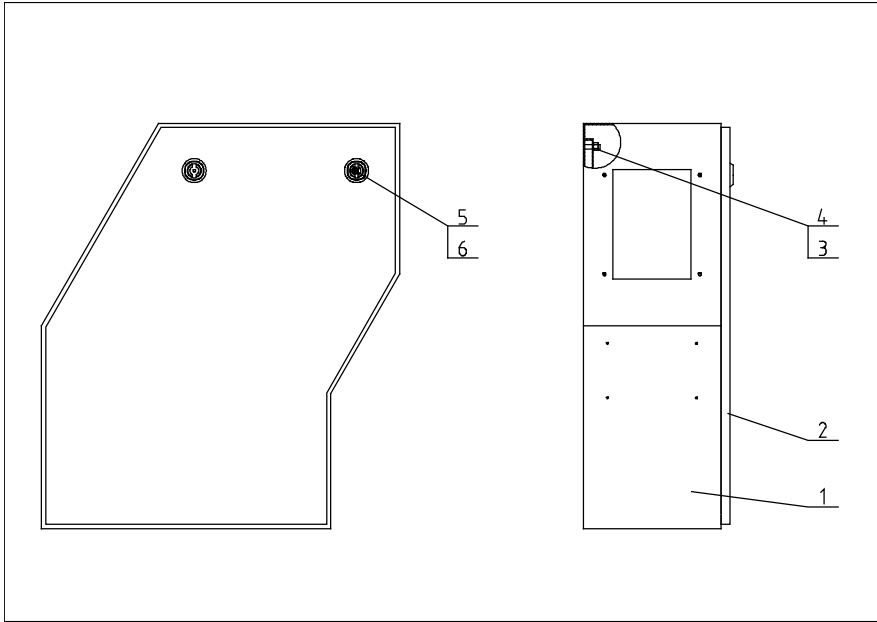

Picture 2-10: Control Box Parts

2.3.12 Control Box Parts List

Table 2-6: Control Box Parts List

No.	Name	Number of.	Part No.
1	Control box	1	-
2	Control box cover	1	-
3	Electrical mounting plate	1	-
4	Nut M5	4	YW64000500000
5	Long door lock	2	YW00000000100
6	Lock pin MF-406-D	2	YW00040600000

2.4 Electrical Diagram

2.4.1 Main Circuit (400V)

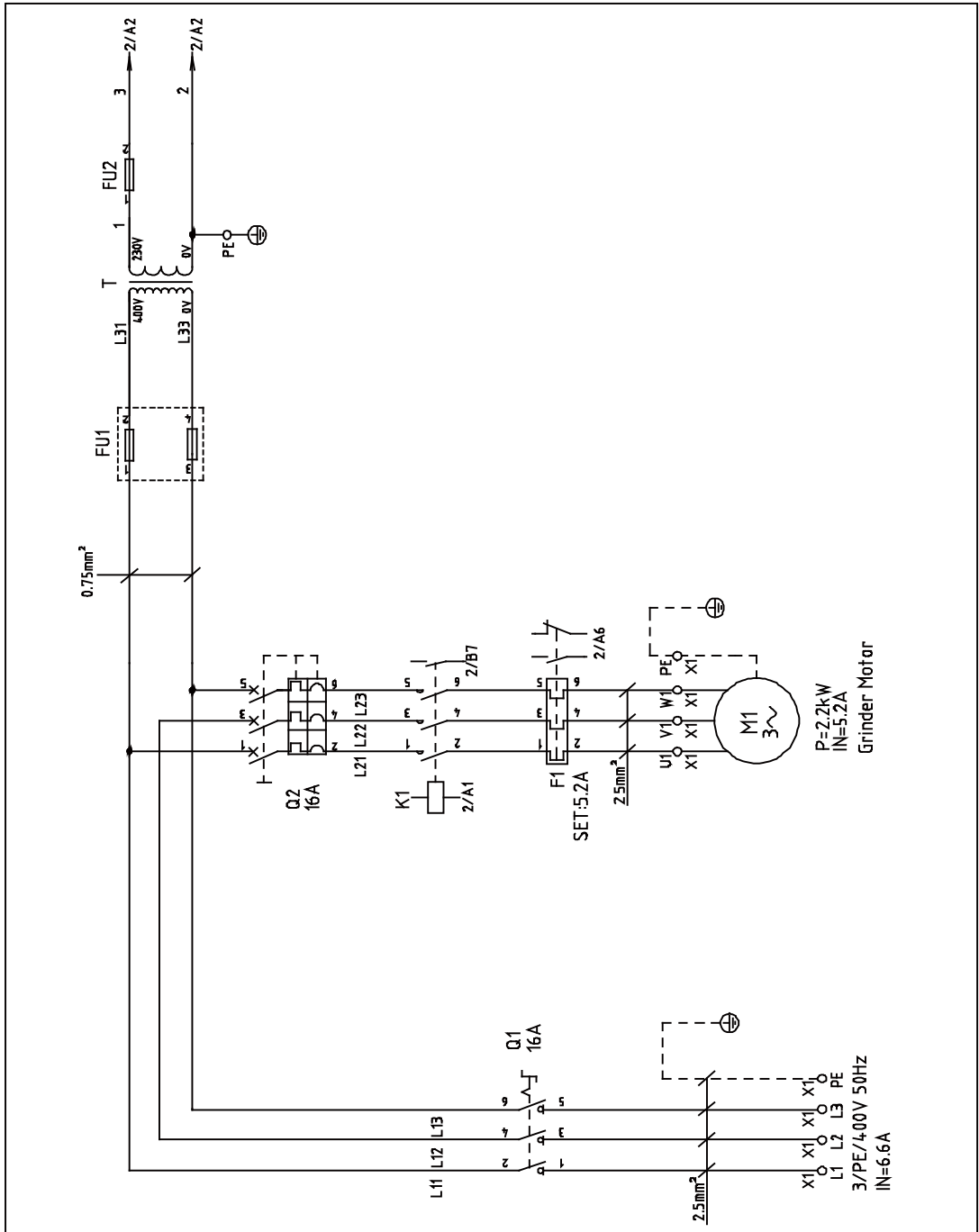

Picture 2-11: Main Circuit (400V)

2.4.3 Components Layout (400V)

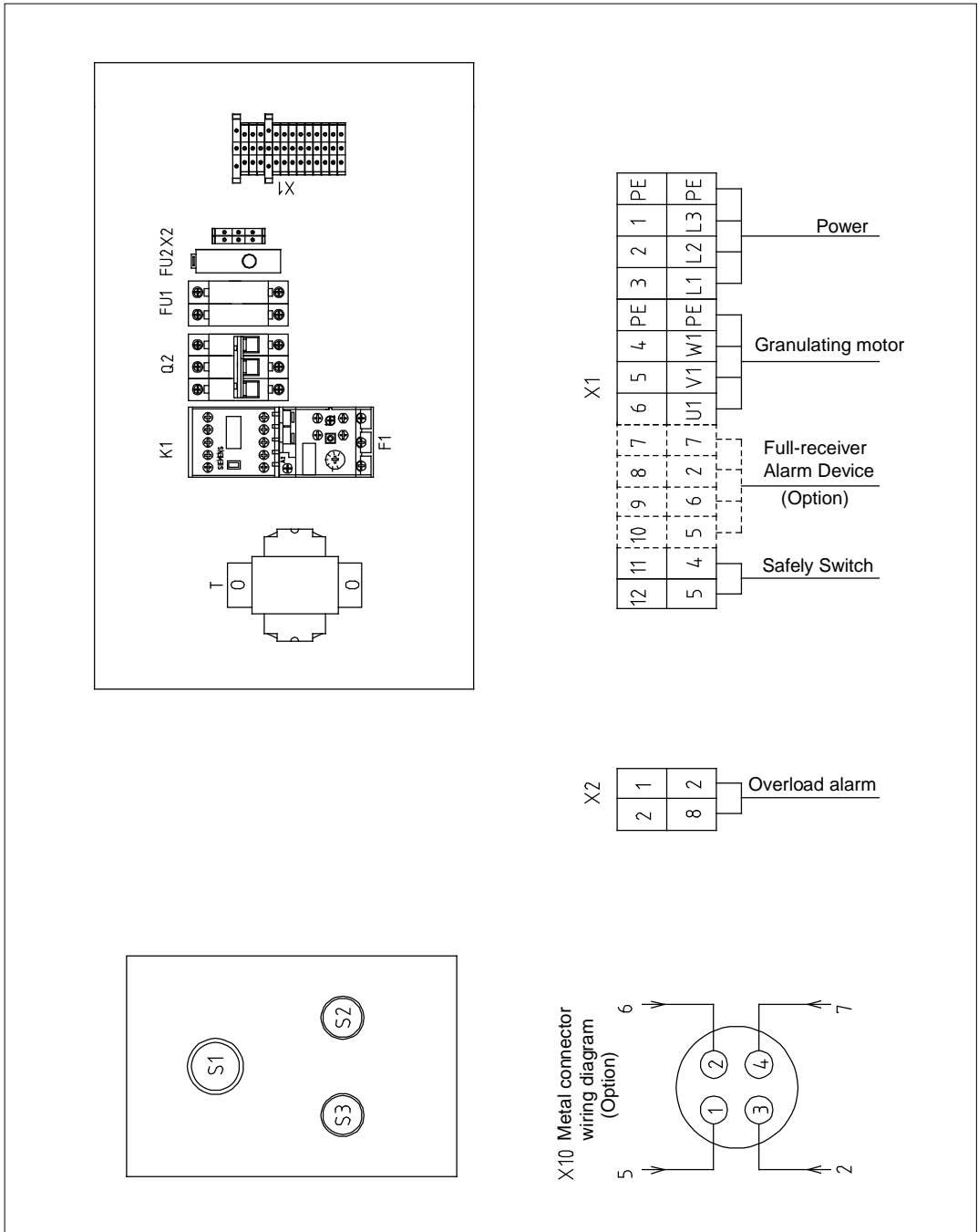

Picture 2-20: Components Layout (400V)

2.4.4 Electrical Components List (400V)

Table 2-7: Electrical Components List (400V)

NO.	Symbol	Name	Specification	Part NO.
1	Q1	Main switch	16A	YE10021160000
2	Q2	Circuit breaker *	16A	YE40301603000
3	K1	Circuit breaker *	220V 50/60Hz	YE00601521000
4	F1	Thermo overload relay*	4.5-6.3A	YE01160450000
5	T	Sensor transformer	500MA	YE70402300800
6	FU1	Fuse*	2P	YE41032200000
7	-	Fuse core *	1A fuse	YE46001000100
8	FU2	Fuse	2A fuse	YE41001000000
9	X1	terminal board/strip	2.5mm ²	YE61250040000
10	-	-	2.5mm ² PE	YE61253500000
11	X2	Terminal board/strip	2.5mm ²	YE61250040000
12	S1	Emergency stop button	400VAC	YE11411000000
13	S2	Stop button	400VAC	YE11113100000
14	S3,H1	Start button	400VAC	YE11100100000
15	S4	Safely Switch	AC17	YE16171100000
16	X10	Metal joint	4P	YE68025400000
17	-	-	4P	YE68025400100
18	MS	Material level sensor	3A/250V	YE15000200100
19	H2	Frequency warning lamp	220VAC	YE83305100200
20	H3	Buzzer	220VAC	YE84222000000
21	M1	Granulatiig motor	400V 50Hz/60Hz	-

* means possible broken parts.

** means easy broken part. and spare backup is suggested.

Please confirm the version of manual before placing the purchase order to guarantee that the item number of the spare part is in accordance with the real object.

2.4.5 Main Circuit (230V)

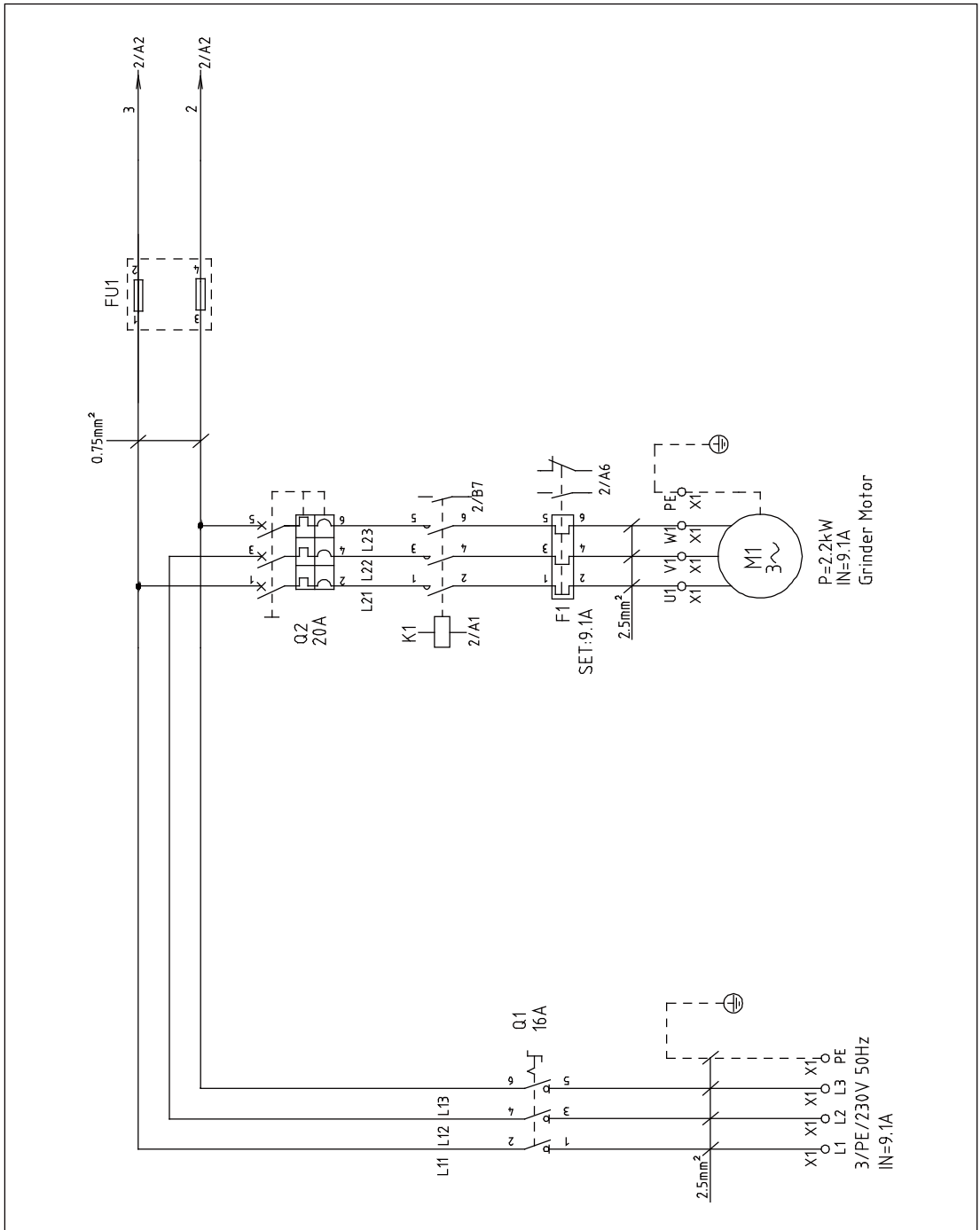

Picture 2-12: Main Circuit (230V)

2.4.6 Control Circuit (230V)

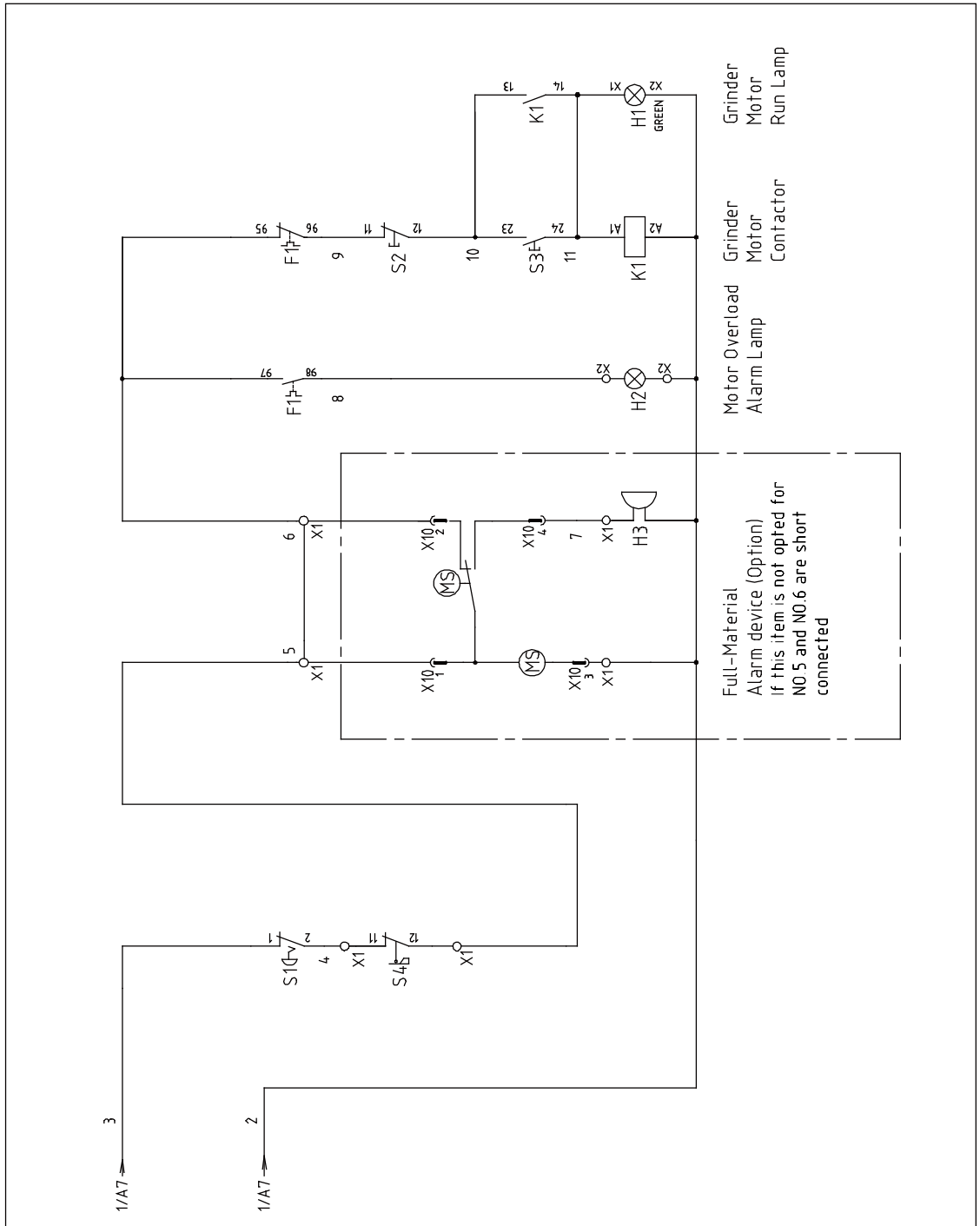

Picture 2-13: Control Circuit (230V)

2.4.7 Components Layout (230V)

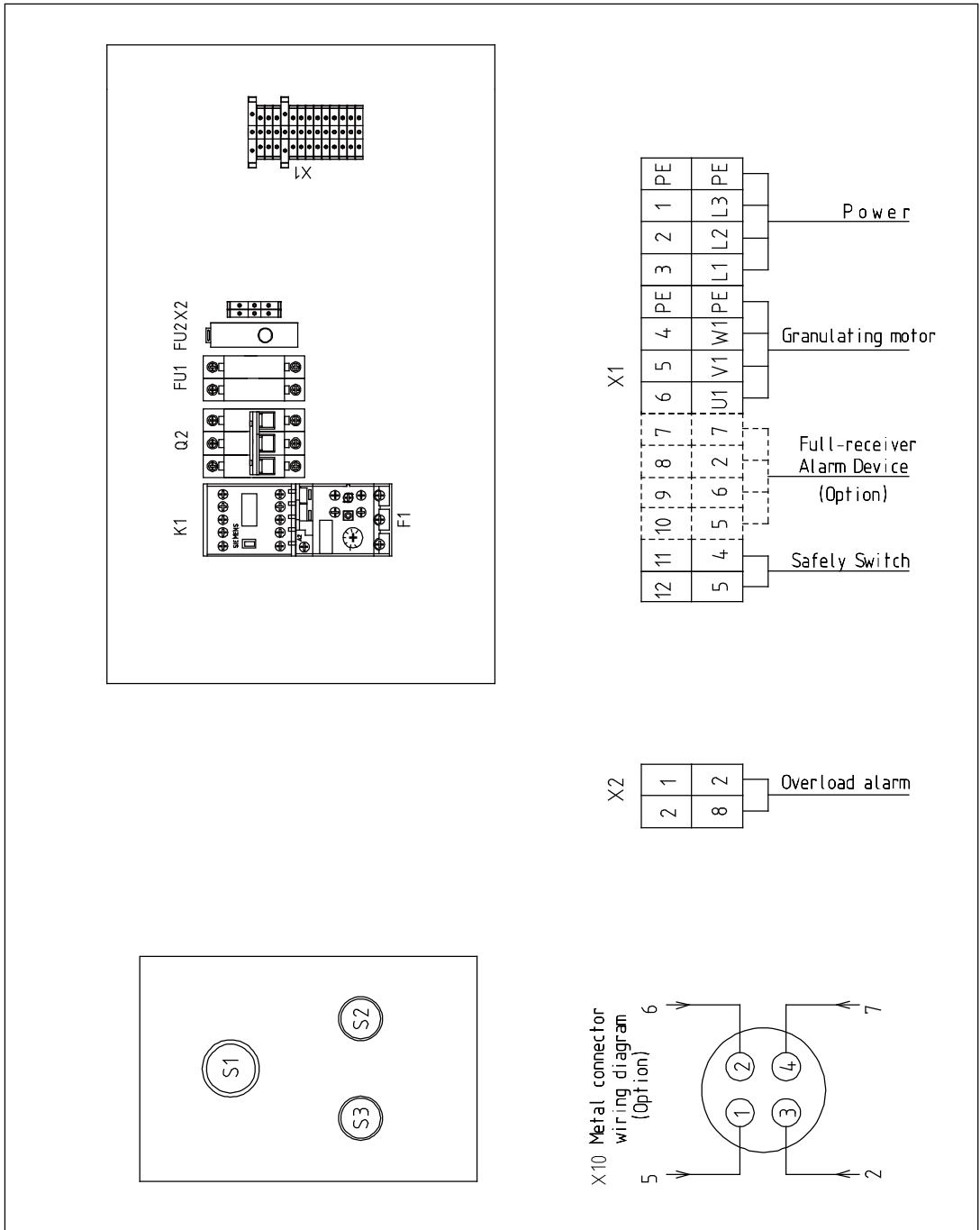

Picture 2-14: Components Layout (230V)

2.4.8 Electrical Components List (230V)

Table 2 8: Electrical Components List (230V)

NO.	Symbol	Name	Specification	Part NO.
1	Q1	Main switch	16A	YE10021160000
2	Q2	Circuit breaker *	20A	YE40302003000
3	K1	Contactor*	220V 50/60Hz	YE00601521000
4	F1	Thermo overload relay*	7-10A	YE01071000000
5	FU1	Fuse*	2P	YE41032200000
6	-	Fuse core *	2A fuse	YE46002000100
7	X1	Fuse core *	2.5mm ²	YE61250040000
8	-	-	2.5mm ² PE	YE61253500000
9	X2	Terminal board/strip	2.5mm ²	YE61250040000
10	S1	Emergency stop button	230VAC	YE11411000000
11	S2	Stop button	230VAC	YE11113100000
12	S3,H1	Start button	230VAC	YE11100100000
13	S4	Safely Switch	AC17	YE16171100000
14	X10	Metal joint	4P	YE68025400000
15	-	-	4P	YE68025400100
16	MS	Material level sensor	3A/250V	YE15000200100
17	H2	Frequency warning lamp	220VAC	YE83305100200
18	H3	Buzzer	220VAC	YE84222000000
19	M1	Granulatiig motor	230V 50/60Hz	-

* means possible broken parts.

** means easy broken part. and spare backup is suggested.

Please confirm the version of manual before placing the purchase order to guarantee that the item number of the spare part is in accordance with the real object.

2.5 Electrical Components Description

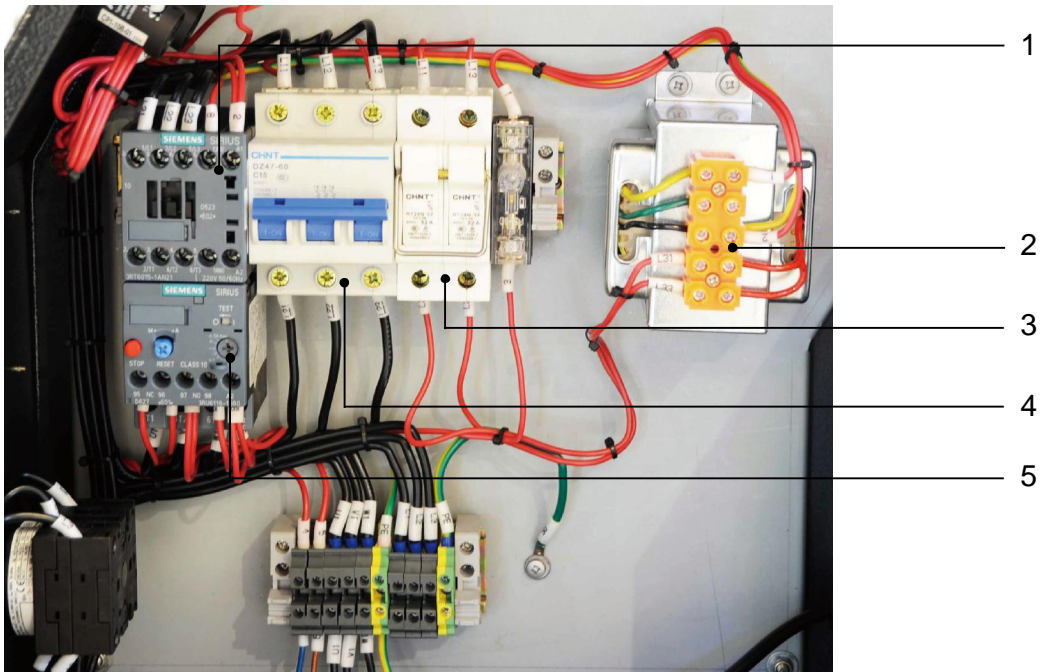

Picture 2-15: Electrical Components Description

1. Contactor, power on or break off the granulating mator.
2. Transformer, which can provide suitable voltage for the control circuit.
3. Fuse, which performs the function of overload, short circuit protection.
4. Circuit breaker, which performs the function of short circuit protection or circuit isolation.
5. Thermo overload relay, which can protect the motor from overloading or phase opening.

2.6 Optional Accessories

2.6.1 Special screen diameter

There are $\Phi 4.0$, $\Phi 6.0$, $\Phi 8.0$, $\Phi 10$, $\Phi 12$ mm for screen diameter.

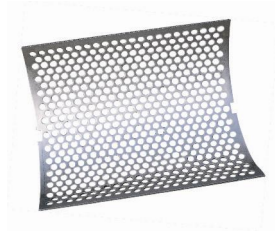

Picture 2-16: Screen

2.6.2 Blade Selection

Material SKD-11 is applicable to cut general plastics.



Picture 2-17: Blade

2.6.3 30-second Instant Recycling System

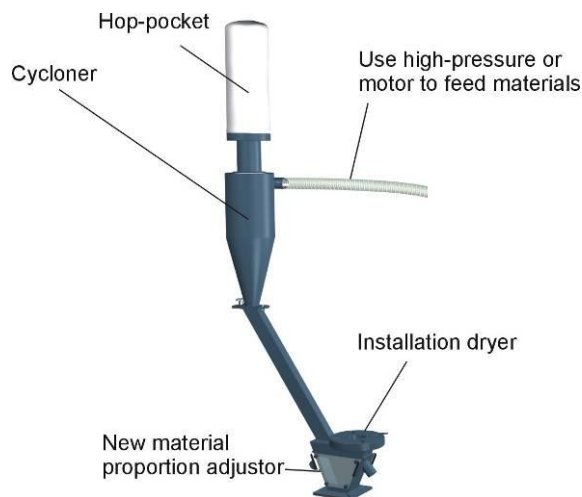

Picture 2-18: 30-second Instant Recycling System

This device utilizes high pressure air or loading blower to easily convey the regrind material in storage box to "new and regrind material proportion

regulation " to get them mixed and recycled, so to keep them from quality and color changing by oxidation or damping.

- 1) Align flange base to the hole of 30-second instant recycling system and use screw of M8×35 to fix it.



Picture 2-19: 30-second Instant Recycling System 1

- 2) Fix the straight pipe and the cyclone dust collector with screw of M5×15 and pay special attention to the direction of the pipe, the same side as inlet of cyclone dust collector is forbidden.



Picture 2-20: 30-second Instant Recycling System 2

- 3) Fix the cyclone dust separator and 30-second instant recycling system, then lock them up with M8 nuts and set screws.



Picture 2-21: 30 Seconds Instant Recycling System 3

4) Put a cloth bag on top of the straight pipe and lock it up.



Picture 2-22: 30-second Instant Recycling System 4

5) Use steel wired hose to connect the outlet of loading blower to the inlet of the cyclone dust collector.



Picture 2-23: 30-second Instant Recycling System 5

6) Mount the dryer on flange base of the 30-second instant recycling system.

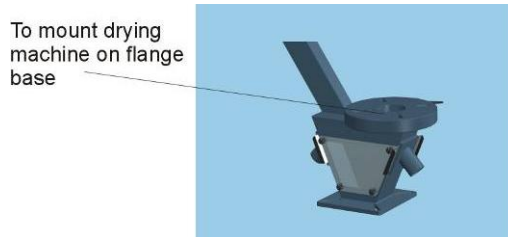

Picture 2-24: 30-seconds Instant Recycling System 6

Option 1: 30-sec instant recycling system model: A (loading with high pressure air).



Picture 2-25: Loading With High Pressure Air

Option 2: 30 secs instant recycling system model: A (loading with blower).



Picture 2-26: Loading With Blower

Option 3: Blower + Cyclonic loading device

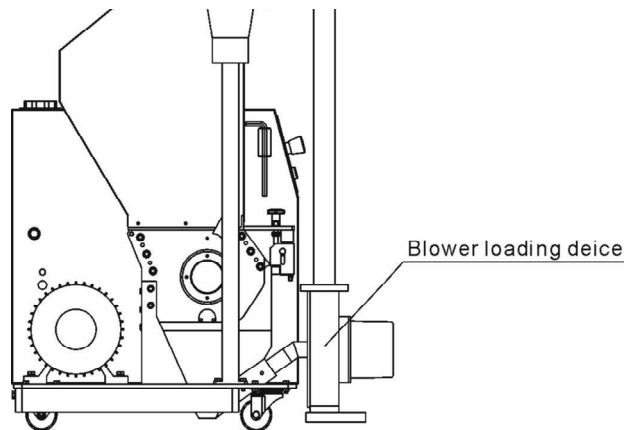

Picture 2-27: Blower + Cyclonic Loading Device

Option 4: Dust separating system

Dust separating system can separate dust from the granules, then store the granules for direct recycling. The regrinds drop into dust separating system after conveyed to cyclone dust separator by high pressure air or conveying motor. There, through screen separator, the dust is sucked into the dust collecting bag while granule is conveyed back to the "new and regrind material proportion regulator" for recycle use. This will prevent sprue material from turning black spot (it is suitable for transparent materials).

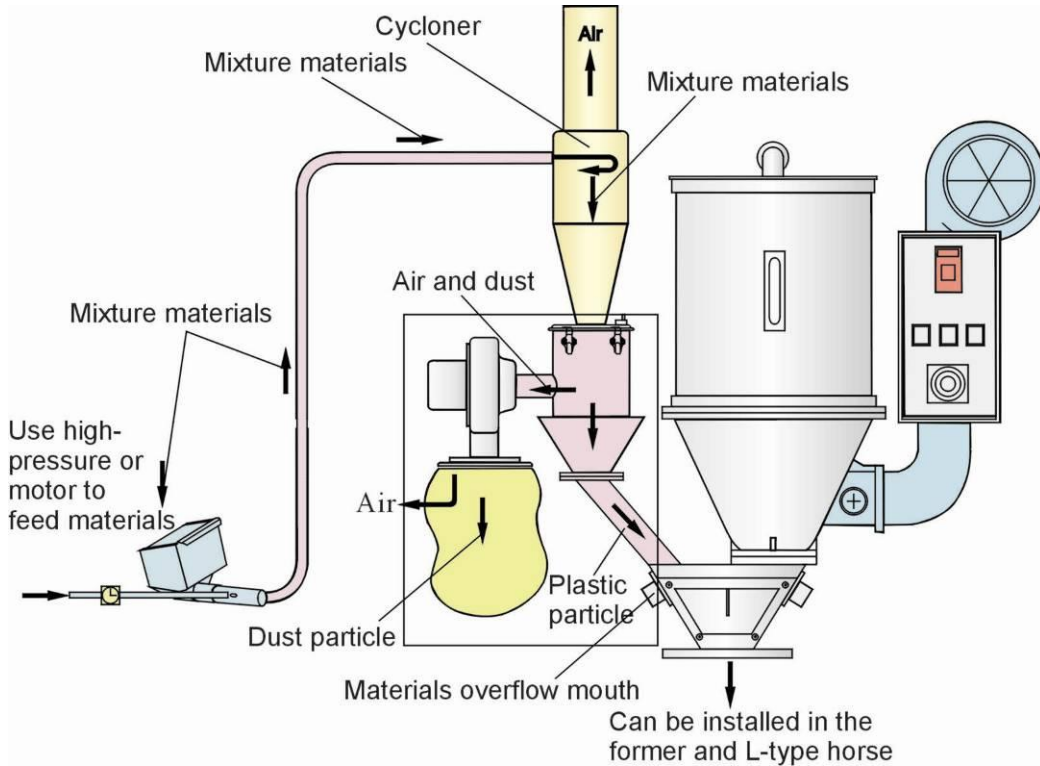

Picture 2-28: Dust Separating System

materials inlet

Can be installed in the molding machine or on L-type floor stand

3. Installation and Debugging



Read this chapter carefully before installation.



Install as following orders to avoid any accident!



Be careful! Not to be cut by the sharp blade.



Power connection must be done by the professional electrician to avoid electrical shock.



Caution!

Cutters should be laid in level, prevent the cutters from self-rotating during installation, don't let your hands near the cutters to avoid personal injury.



Notice!

Do not install the cutters by working together, because this could bring personal injury. Use a thick wood block on cutting chamber to stop the rotating knives from turning.



Notice!

The blades are very sharp, so use protective gloves to avoid being cut.



Notice!

Please use new screws and gaskets when installing cutters.

3.1 Installation Notice

- 1) Make sure voltage and frequency of the power source comply with those indicated on the manufacture's plate, which is attached to the machine.
- 2) Power cable and earth connections should conform with local regulations.
- 3) Use independent power cable and ON/OFF switch. The cable's dia. should not smaller than those applied in the control box.
- 4) The power cable connection terminals should be tightened securely.
- 5) The machine requires a 3-phase 4-wire power source, connect the power lead (L1, L2, L3) to the live wires, and the earth (PE) to the ground.
- 6) Power supply requirements:
 Main power voltage: $\pm 10\%$
 Main power frequency: $\pm 2\%$
 Make at least 1 meter clearance around the machine to facilitate repair and maintenance.



Picture 3-1: Installation Layout

Table 3-1: Cutters and Other Fixing Screw Torque

Thread size	M10	M12	M14	M16	M18	M20	M22	M24
Axial force (N)	23.8	34.5	47	65.5	78.5	103	129	149
Fixing torque (Nm)	50	86	135	215	290	420	570	730

3.2 Installation Location



Make enough installation space to help machine repair and maintenance.

Check and make sure the installation ground is level and there is enough intensity when it is running.

Lock up the castors to prevent the granulator from moving.

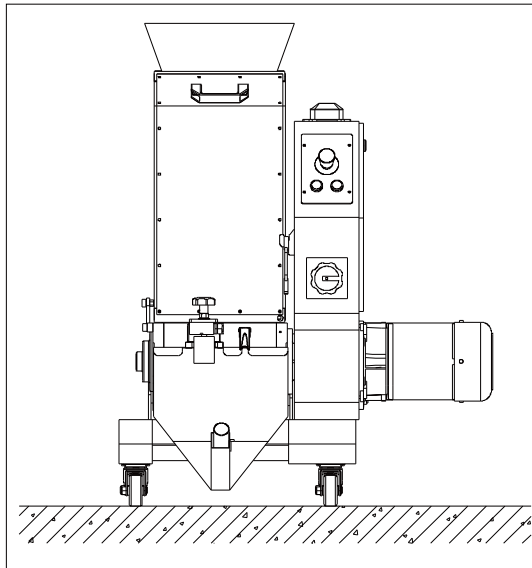

Picture 3-2: Installation Layout

3.3 The Installation of Cutting Chamber

1) Lift the Cutting Chamber



Picture 3-3: The Installation of Cutting Chamber

- 2) Aim the left/right square holes of bottom cutting chamber to corresponding holes on the rack, then lock the cutting chamber to the rack with screws.

3.4 Installation of Rotating Blade and fixed Blade



Notice!

The blade is sharp edged, please wear gloves before installation and care shall be taken when installation to avoid injury!

Installation steps:

- 1) Put the rotating blades on rotating blade retainer.

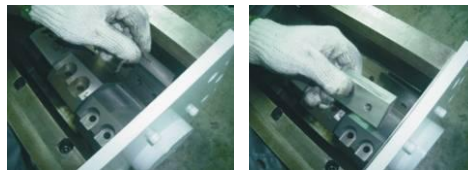

Picture 3-4: Installation of Rotating Blade and Fixed Blade 1

- 2) Lock the screws corresponding to blades with proper torque. (Torque: 43Nm)



Picture 3-5: Installation of Rotating Blade and fixed Blade 2

- 3) Put the pressing blocks onto the fixed blades, align screws to the fixing holes and lock them tightly.



Picture 3-6: Installation of Rotating Blade and fixed Blade 3

- 4) Use proper small wrench to adjust the distance of fixed blades and rotating blades to 0.2~0.3mm (Picture 5.4-5) and lock the fixed blade tightly.



Picture 3-7: Installation of Rotating Blade and Fixed Blade 4



Notice!

To avoid human injury and machine damage, the fixing screw of blades shall be tightened well.

When adjusting the clearance, it shall not be too small to avoid damage to the cutter!

3.5 Installation of Feed Box Components

- 1) Lift up the feed box (figure 1) to fix it onto the cutting chamber. Clean up impurities on the contacting interface, thus use fixing rod (figure 2) to fix it onto the cutting chamber.

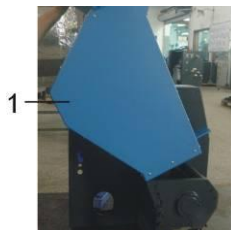

Picture 3-8: Installation of Feed Box Components 1

- 2) Hold material inlet (figure 3), put it onto the feed box and lock up it with screws

corresponding to the holes.



Picture 3-9: Installation of Feed Box Components 2



Attention!

Lock each screw with right torque (5.9Nm).

3.6 Installation of Storage Box

- 1) Move the material storage box as arrow direction showed in picture (3-10) below.



Picture 3-10: Installation of Material Storage Box 1

- 2) Move up material storage box the direction as arrow showed, then pull back and make the edgefold (2) of the box hang up to edgefold (1) of the siding.

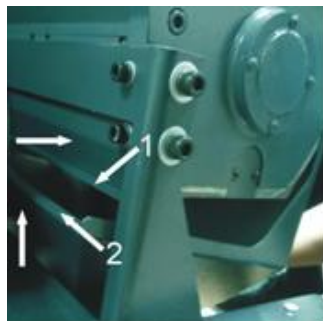

Picture 3-11: Installation of Material Storage Box 2

- 3) According to picture 3-11, the suction box after installation, as picture 3-12

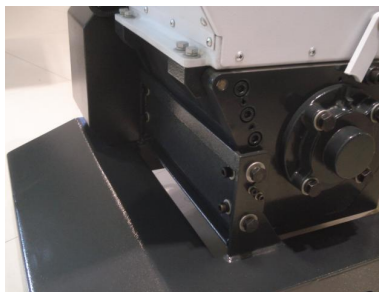

Picture 3-12: Installation of Material Collection Box 3

4) Fasten the snap hook and finish the installation of material storage box. See picture below.

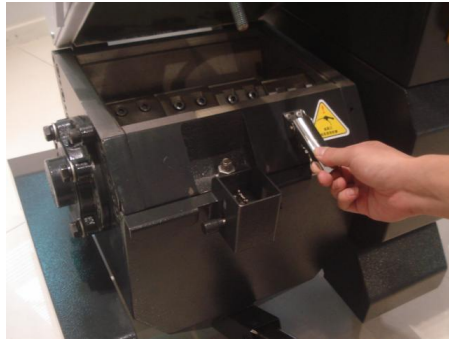

Picture 3-13: Installation of Material Storage Box 4

4. Operation Guide



Wear earplugs during operating to avoid personal injury!



Wear gloves during operating to avoid personal injury!



Wear goggles during operating to avoid personal injury!



Because the blades and rotors may be loosen, check the following items before operating:

- 1) If the blades has any damage.
- 2) If the surface of the rotor is loosen.
- 3) Push or pull the rotor and blades to see if there is any loose connection.

If any of the above situations is found, please contact local representative or SHINI Company for help.

4.1 Startup Pretest

Unpainted part of the machine has been covered with stainless oil. Before use, the stainless oil should be cleaned.

- 1) Clean with a towel.
- 2) Wash with a towel dipping with amyl acetate.

4.1.1 Before the First Startup

- 1) Check whether the granulator is in the level state.
- 2) Check the space of the cutting tools to see whether the lockup screws of the blades are tightened (torque: 280Nm).

4.1.2 After First Startup for 2 Hours

- 1) Check the clearance of the cutting tools of the fixed blades and rotating blades again; check whether the lockup screws of the blades are loose.

4.2 Circuit Connection



CAUTION!

The installation of the granulator's circuit must be conducted by the professional electricians.

- 1) Connect power to the granulator.
- 2) Connect the transmission belt clockwise.

4.2.1 Check the Running Direction of the Motor

- 1) Open the door to check whether the feed box is closed.
- 2) Ensure the main power switch is in ON position.
- 3) Check the emergency stop.
- 4) Start the granulator by pressing the START button and stop the granulator by pressing the STOP button.
- 5) The granulator needs some time to fully come to a halt; After full stop, check whether the running direction is clockwise.



CAUTION!

The cutting tools may be damaged and the granulating capability will be reduced if there is a wrong running direction. Please disconnect the power and transpose any two wires of the three in the main power.

4.3 Open the Feed Box, Screen Bracket and Storage Box



Attention!

Before opening the feed box and the storage box, turn off the main power switch and the power switch of the granulator.



Attention!

Be careful! The blade is very sharp, please take care.

4.3.1 Open the Feed Box

- 1) Check if the feed box has been emptied. If so, turn off the main power switch.
- 2) Loosen the long screw shaft and open the feed box.



Picture 4-1: Open the Feed Box

4.3.2 Open the Storage Box

- 1) Shut off the power of granulator.
- 2) Loosen the snap hook, open the storage box.

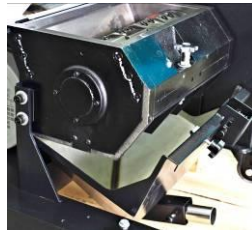

Picture 4-2: Open the Storage Box

4.3.3 Open the Screen Bracket

- 1) Shut off the power of granulator.
- 2) Loosen the inner hexagon screws and open the screen bracket.



Picture 4-3: Open the Screen and Screen Bracket 1

3) Take Out the Screen



Picture 4-4: Open the Screen Bracket and Screen 2

4.4 Close the Feed Box and Storage Box

4.4.1 Close the Feed Box

- 1) Check to ensure there is no powder left in the interface or corners.
- 2) Close the feed box forwardly.
- 3) Lock up the star screw and fix the feed box.

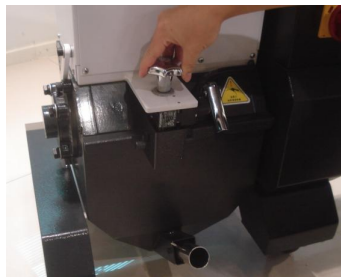

Picture 4-5: Close the Feed Box

4.4.2 Close the Storage Box



Attention!

Before closing, clean the interface surface.

Be careful!

Don't get squeezed and injured.

- 1) Check no powder or leftover material around the cutting chamber, screen and screen bracket; periodically clean it if there's any.
- 2) Mount the screen and lock up the fixing nuts of the screen bracket tightly.
- 3) Mount the storage box and lock up its star screw tightly.

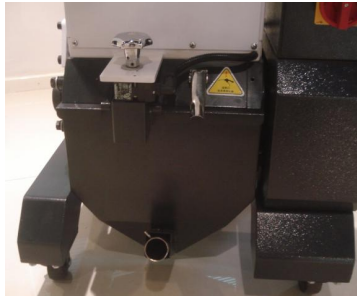

Picture 4-6: Close the Storage Box

4.5 Startup and Stop the Granulator

The granulator is controlled by breaker interlock, safety switch, “START / STOP” button and “emergency stop button”.

Emergency and startup button:

It is located at the front control panel. It through rotating the switch to control the startup and stop of the machine.



Picture 4-7: Main Power Switch

START button and STOP button:

These two buttons control the startup and stop of the machine.

Emergency Stop:

When accident happens, this button can help to emergency stop the machine. .

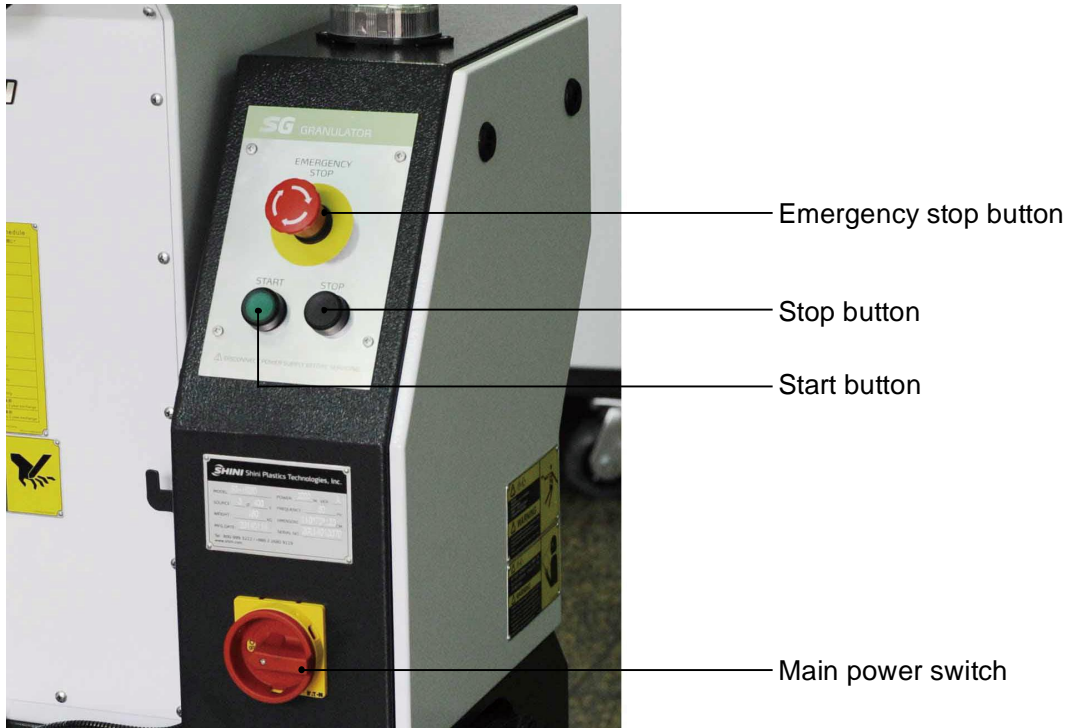

Picture 4-8: Stop, Emergency Stop and Startup button



CAUTION!

If there are ungrinded raw materials in the feed box or cutting chamber, the granulator shall NOT be stopped, otherwise the raw materials will blockade the rotor and the motor will be overloaded next time you start up the machine.

5. Troubleshooting

5.1 Granulator Can Not Work

- 1) Check if the emergency stop has been reset or not. If not, rotate the button anti-clockwise to reset it.
- 2) Check if the safety switch between feed box and storage box is completely closed. If not, machine can not be started.
- 3) Checking overload protector of the motor.

The overload protector in the electrical control box will work if the motor overloads. Test white key (A) turn left, press the “Reset” button (B) to reset it. Before it starts again, check whether there is any powder left in the granulator.

- 4) Check the overload protector of the feeding blower's motor.

If the feeding blower does not run, the granulator can run neither. Check the motor protector in the electric control box. If the protector is closed, the switch will be at “0” position, reset it to “1” position. Check if there’s no leftover, then re-start the machine. Test the white key(A) turn left, press” Reset” key (B) to reset it.

- 5) Check the clearance between the blades

The stop will happen or the motor overload protector will work if the blade is very blunt or the space between blades is not correct. Protector will be tripped if motor is overload. Blades should be checked, replaced or adjusted between the blades.

- 6) The contactor is burnt down or the control circuit is break off.

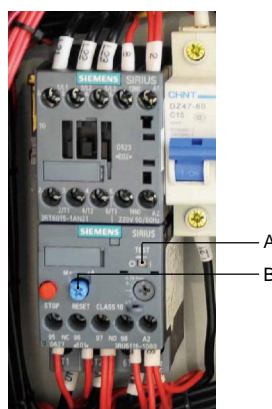

5.2 Stop Due to Other Reasons

Connection failure or looseness of safety switch or limit switch can also result in operation failure.



Attention!

Do not disconnect to safety switch or control switch.

6. Maintenance and Repair

6.1 Repair

All the repairs must be done by professionals to avoid damage to machine and injure human body.

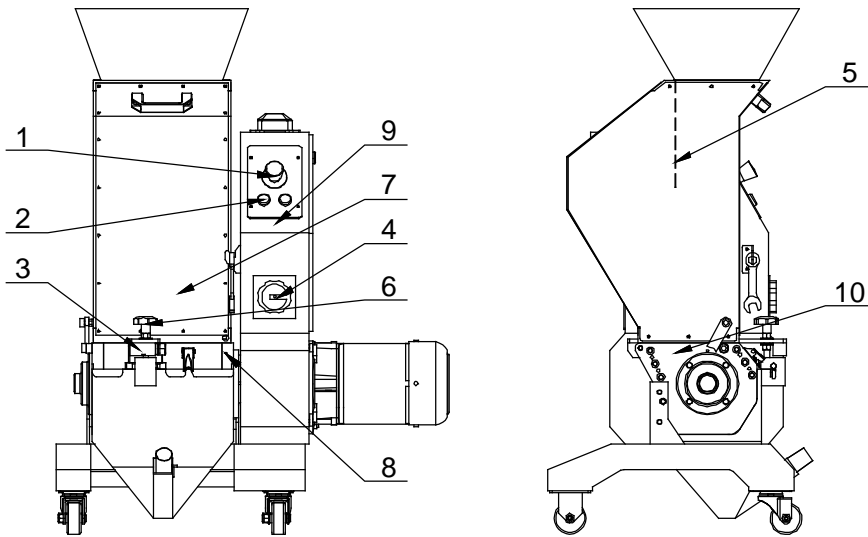

1. Check the emergency stop switch. period: daily
2. Check the on/off button. Period: daily
3. Check the safety switch. Period: daily
4. Check the main power switch. Period: daily
5. Check the material fender before startup. Period: daily
6. Check whether the star knob and the inner hexagon screw below it are tightened up before startup. Period: daily
7. Check whether there are materials in the cutting chamber before startup. Period: daily
8. Blow compressed air into material clear hole and rotate blades. Period: daily
9. Check whether components in the electric components box are loose. Period: weekly
10. Check whether the fixed blades and rotary blades are loose. Period: monthly

6.1.1 Blades Structure in Cutting Chamber

SG-1628D series adopt new type staggered blades and free-adjustment movable rotating blades which can keep a settled cutting clearance without adjustment after resharpening. Following picture is the blades structure in cutting chamber:

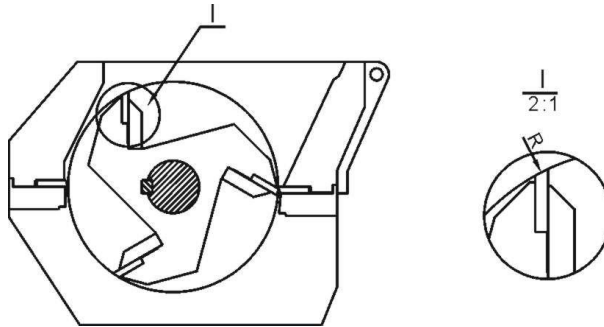

Picture 6-1: Blades Structure in Cutting Chamber

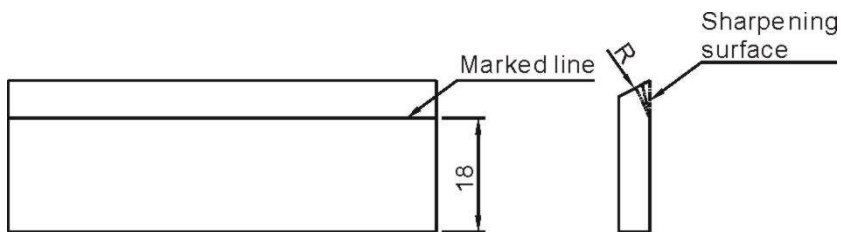

Picture 6-2: Rotating Blades Sharpening

6.1.2 Replacement of Blades



CAUTION!

Warning: Rotating blades of cutting chamber should be stress balanced. So during blades installation, it will start self-rotation due to unbalanced stress.



Attention!

When centre of its gravity is unstable, it will start self-rotation too.

Wear gloves to avoid being cut and be careful of the sharp blades!

More details about blades replacing or maintaining refer to chapter 3.4.

Assembly of Fixed Blades and Rotating Blades, after locking up of each screw, inject with thread fixatives (light green is recommended, LOCTITE243) at screw-thread connection port, as to fix the screws and to avoid screw slipping.



Press emergency stop button and turn off main power switch during blades replacement!



Wear gloves to avoid being cut and be careful of the sharp blades! More details about blades replacing or maintaining refer to chapter 3.4. Inject with thread fixatives (light blue is recommended, LOCTITE243) at screw-thread connection port, as to fix the screws and to avoid screw slipping.



Picture 6-3: Blade Maintenance and Cleaning



CAUTION!

To decrease the possibility of other people's injury, the replacement action must be conducted by oneself as there's no help.



CAUTION!

To avoid self-rotation, block the rotating blades with a thick wood block. Be careful with the sharp blades.

CAUTION!



Each time of blade replacement, the screw and the washer must be replaced too. .

Before blade replacement, open the feed box, dismantle the storage box, screen and screen frame.

1) Dismantle the Fixed Blades



CAUTION!

To avoid self-rotation, block the rotating blade with a thick wood block.

- 1) Remove the screws and the washers.
- 2) Remove the blades.
- 3) Clean the installation surface of the blades.

2) Remove the rotating blades

1. Loosen and remove the inner hexagon screws.
2. Clean the whole rotating blades and cutting chamber.



CAUTION!

Press the pressing block and blade when you remove the last screw.

3) Blade Installation

Clean carefully the fixed blades and rotating blades and then install them.



CAUTION!

Each time to replace the blades, the screw and washer must be replaced too. Install the back fixed blades then the front fixed blades, and at last the rotating blades. More details about blades replacement or maintenance refer to chapter 3.4 Fixed and Rotating Blades Installation.

4) Check the Blades

Turn around the blade rest till all the blades can rotate freely.

6.2 Maintenance

During maintenance, to ensure that there is no material left in the granulator.

**CAUTION!**

All repairs must be completed by professionals to avoid human damage or harm to the machine.

6.2.1 Daily check

- 1) There is rubber shutter in the feed box. If the rubber shutter is damaged, replace it immediately. Otherwise the fragments of the shutter will damage the blades when dropping into the cutting chamber.
- 2) Check whether the emergency stop works properly. Start the machine and then stop it via emergency stop. Rotate the button anti-clockwise as the arrow indicated to reset the emergency stop.
- 3) Check main power if switches work normally or not.
- 4) Check star screw, safety screw is part of granulator' safety system, its length is pre-designed, when the screw is loosen, the granulator will stop working so to protect the machine. The thread length of the safety screw is 85 mm, damaged screw needs to be replaced by a new one.

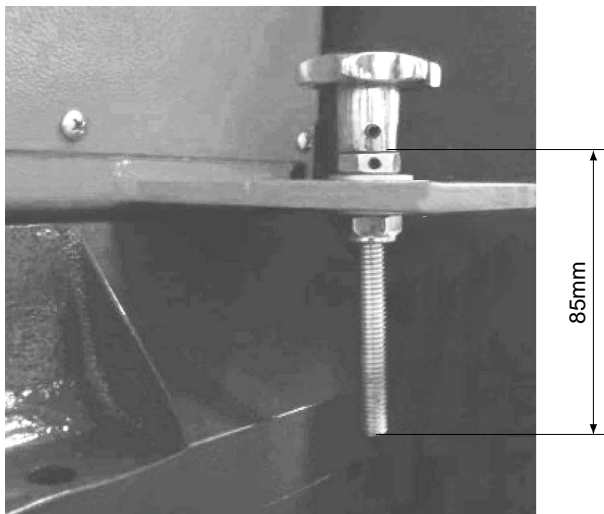

Picture 6-4: Star Screw

6.2.2 Weekly Check

- 1) Check working condition of the motor.

6.3 Cleaning



Caution:

Cutting blades are very sharp, extremely caution must be paid when working under opening of cutting chamber.

- 1) Check the cutting chamber is empty before stopping the granulator.
- 2) Switch off the main power
- 3) Cleaning fender of the feed box with dust-collecting device.
- 4) Cleaning external surface of the feed box.
- 5) Open the feed box back forward.
- 6) Clean internal surfaces of the feed box.
- 7) Remove and clean the material storage box.
- 8) Clean screen and screen bracket.
- 9) Clean outer and inner of cutting chamber.
- 10) Blowing to clearance hole at side plate of cutting chamber with compressed air (A), at the same time rotate the blade rest to remove cutting material inside bearing block. Suggest do cleaning once a day.

Pressed air A



Picture 6-5: Dust Collection Chamber Cleaning



Caution!

Cover safety switch with a protective sleeve to avoid dusts.

6.4 Maintenance Schedule

6.4.1 About the Machine

Model _____ SN _____ Manufacture date _____

Voltage _____ Φ _____ V Frequency _____ Hz Power _____ kW

6.4.2 Check after Installation

- Check if pipe connections are firmly locked by clips.
- Check the gap between fixed blade and rotating blade. (0.2mm).
- Check the rotating balance of the belt wheel.

Electrical Installation

- Voltage: _____ V _____ Hz
- Specs of the fuse: 1 Phase _____ A 3 Phase _____ A
- Check phase sequence of the power supply.
- Check the rotating direction of the conveying blower.

6.4.3 Daily Check

- Check main power switch.
- Check emergency stop button.
- Check start / stop button.
- Check material fender (strip) is intact or not.
- Check whether emergency stop and safety switch works normally.
- Clean screen and feeding hopper.
- Check whether start, stop and main power switches are normal.

6.4.4 Weekly Check

- Check all the electrical cables.
- Check if there are loose connections of electrical components.
- Check blade condition.
- Check whether set screws of fixed and rotating blades are loose or not.
- Check if there is abnormal noise, vibration and heating of gear motor.
- Check the material fender.

6.4.5 Monthly Check

- Check the status of gear motor.

- Check the overload protection function of the motor.
- Check motor reversed running function.
- Check the tightness of the blades.
- Check whether sleeve of pulley belt is fastened.
- Check belt tension.

6.4.6 Check Half-yearly or Every 1000 Running Hours

- Check or replace lubrication for gear motor.
- Check lubrication of bearing.
- Check coupling.
- Evaluate the condition of machine.

6.4.7 3-yearly Check

- PCB board replacement.
- No-fuse breaker replacement.