

型号/SYMBOL 型号/MODE	ⓐ	ⓑ	ⓒ	ⓓ	ⓔ	ⓕ	ⓖ	ⓗ	ⓘ	ⓙ
STM-607	17.5	4.0	25	0.55	1.7	6	15.8	1.5	4.0	25
STM-910	26.7	6.0	4.0	0.75	3.1	9	23.6	1.5	6.0	32
STM-1220	37.4	6.0	50	1.5	5.9	12	31.5	1.5	6.0	63

					制图	版号	D	标题	STM-607/910/1220-EB	图号	STM-607/910/1220-EB-230V-D-1	比例	第 1 张
					设计	核准		主电路图				标准	共 5 张
					校对			信易电热机械股份有限公司 Shini Plastics Technologies, Inc.	机器电压		3/230V		
标记	更改前	更改后	更改人	日期	审核	日期	20221013		机器频率		50Hz		

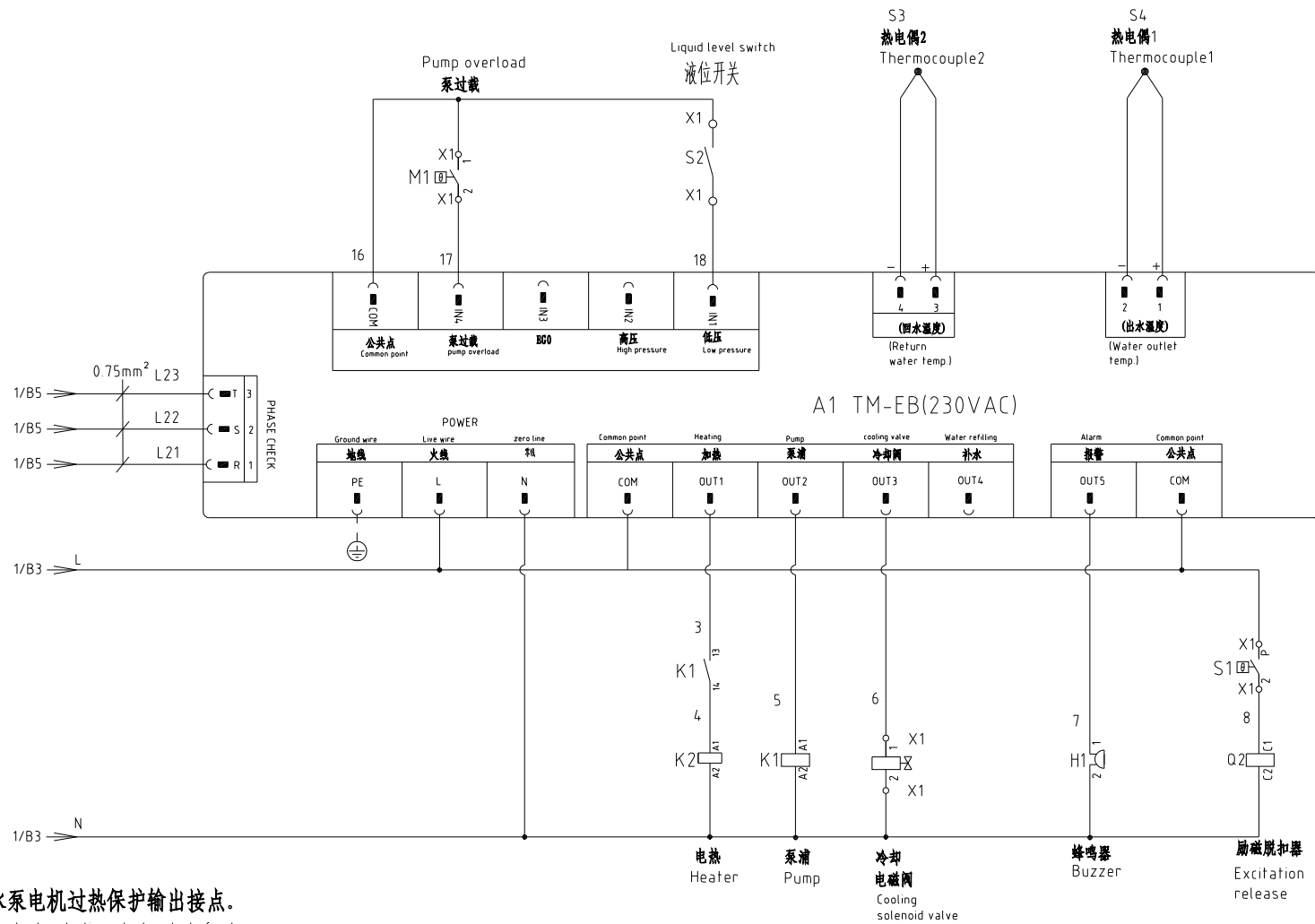

注：M1为水泵电机过热保护输出接点。

Note: M1 is the overheat protection output contact of water pump.

					制图	版号	D	标题	STM-607/910/1220-EB	图号	STM-607/910/1220-EB-230V-D-2	比例	第 2 张
					设计	核准		控制电路图				标准	GB 共 5 张
					校对	核准			信易电热机械股份有限公司		机器电压	3/230V	
标记	更改前	更改后	更改人	日期	审核	日期	20221013		Shini Plastics Technologies, Inc.		机器频率	50Hz	

1 2 3 4 5 6 7 8

技术要求: (1) 热电偶正 (+) 负 (-) 极直接接到线路板的热电偶输入端, 不经过端子排。

(2) 电热和泵浦直接接触器输出端。

Technical requirements:

(1) Positive (+) and negative (-) poles of thermocouple should be directly connected to thermocouple's input terminal of circuit board. There is no need for them to go through the terminal board.

(2) the heater and bump directly connect to contactor output.

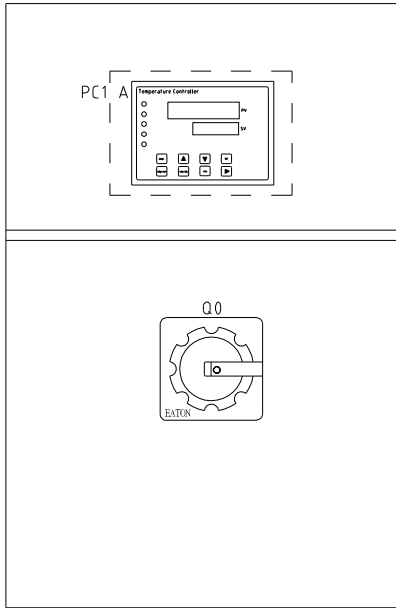

电箱面板
Electric box panel

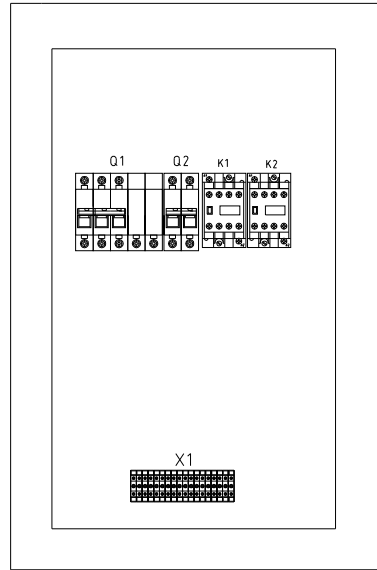

电箱底板
Base plate of electrical box

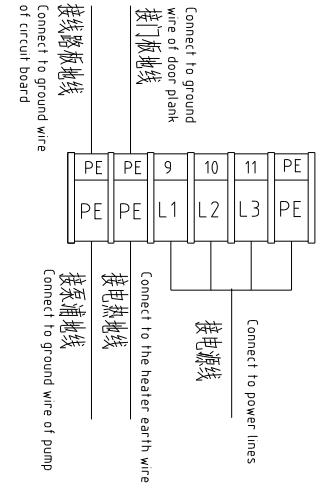
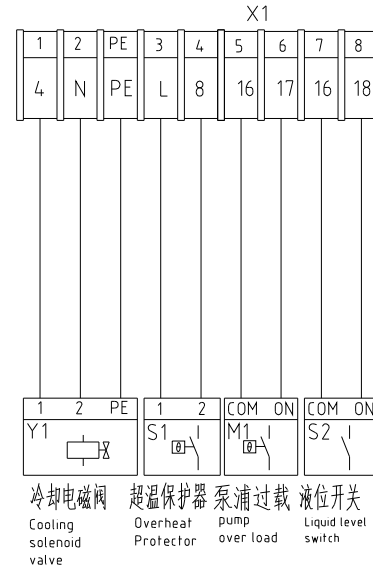

					制图	版号	D	标题	STM-607/910/1220-EB	图号	STM-607/910/1220-EB-230V-D-3	比例	第 3 张
					设计	核准		电气布置及端子接线图				标准	GB 共 5 张
					校对	审核		信易电热机械股份有限公司 Shini Plastics Technologies, Inc.		机器电压		3/230V	
标记	更改前	更改后	更改人	日期	20221013	日期	20221013			机器频率		50Hz	

1		2		3		4		5		6		7		8		
序号/NO	符号/Symbol	名称/Name		制造商/Manufacturer		型号/Type		规格/Specification		数量/Number	物料编号/Material number		备注/Remark			
A	1	Q1	断路器/Circuit Breakers		TECO		BM-63C		25A		1	YE40302503000		for 607-EB		
	2		断路器/Circuit Breakers		TECO		BM-63S		40A		1	YE40304003000		for 910-EB		
	3		断路器/Circuit Breakers		TECO		BM-63C/3032S		50A		1	YE40305003000		for 1220-EB		
	4		励磁脱扣器/Excitation release		CHINT		MX		230VAC		1	YE40023560000				
	5	Q2	断路器/Circuit Breakers		TECO		BM-63C/2003S		2P 3A		1	YE40200203000				
	6	K1	接触器/Contactors		SIEMENS		3RT6015-1AN21		220V 50/60Hz		1	YE00601521000				
	7	K2	接触器/Contactors		SIEMENS		3RT6026-1AN20		220V 50/60Hz		1	YE00602622000		for 607-EB		
B	8		接触器/Contactors		SIEMENS		3RT6027-1AN20		220V 50/60Hz		1	YE00602722000		for 910-EB		
	9		接触器/Contactors		SIEMENS		3RT6028-1AN20		220V 50/60Hz		1	YE00602822000		for 1220-EB		
	10	S1	突跳式超温保护器/Snap action overheat protector		---		KSD301-20.5/10BL16K30-G/205/额定 normally open 205℃				1	YE90030100300		(1)		
	11	S2	微动开关/Micro switch		JUCHE		LXW5-1124 样长 rod length :100MM		250V 50HZ		1	YE14152400000		(1)		
	12	S3	热电偶/Thermocouple		SHINI		----		K		1	----		(1) (2)		
	13	S4	热电偶/Thermocouple		SHINI		----		K		1	----		(1) (2)		
	14	A1	TM-EB	线路板/Circuit Board		YUYUN		TM-EB 220VAC 宇韻 YuYun		180~4.30V 50/60Hz		1	YE81081100100			
15																
C	16	X1	端子排/Terminal Board		PHOENIX		2.5mm ²		----		8	YE61250040000		for 607-EB		
	17		接地端子排/Grounding terminal board		PHOENIX		2.5mm ² PE		----		1	YE61253500000		for 607-EB		
	18		端子排/Terminal Board		PHOENIX		2.5mm ²		----		8	YE61250040000		for 910-EB		
	19		接地端子排/Grounding terminal board		PHOENIX		2.5mm ² PE		----		1	YE61253500000		for 910-EB		
	20		端子排/Terminal Board		PHOENIX		6mm ²		----		3	YE61060000000		for 910-EB		
	21		接地端子排/Grounding terminal board		PHOENIX		6mm ² PE		----		3	YE61063500000		for 910-EB		
	22		端子排/Terminal Board		PHOENIX		2.5mm ²		----		8	YE61250040000		for 1220-EB		
	23		接地端子排/Grounding terminal board		PHOENIX		2.5mm ² PE		----		1	YE61253500000		for 1220-EB		
	24		端子排/Terminal Board		PHOENIX		6mm ²		----		3	YE61060000000		for 1220-EB		
	25		接地端子排/Grounding terminal board		----		6mm ² PE		----		3	YE61063500000		for 1220-EB		
注: (1)表示非电控箱内材料; (2)表示选配出水 and 回水温度显示功能; Notes: (1)Means it's not the material inside the control box. (2)Means equipped with function of displaying water outlet and return water temperature.																
D					制图		版本号		D		标题 STM-607/910/1220-EB		图号		比例	
					设计		核				元件明细表-		STM-607/910/1220-EB-230V-D-4		标准 GB	
					校对		准				 信易电热机械股份有限公司 Shini Plastics Technologies, Inc.		机器电压		3/230V	
	标记		更改前		更改后		更改人		日期				20221013		机器频率	
1		2		3		4		5		6		7		8		

1		2		3		4		5		6		7		8			
序号/NO	符号/Symbol	名称/Name		制造商/Manufacturer		型号/Type		规格/Specification		数量/Number	物料编号/Material number		备注/Remark				
A	1	M1	马达/Motor		SHINI		TP-55		230V 50Hz 0.55kW		1	----		(1) for 607-EB			
	2		马达/Motor		SHINI		TP-75		230V 50Hz 0.75kW		1	----		(1) for 910-EB			
	3		马达/Motor		SHINI		TP-150		230V 50Hz 1.5kW		1	----		(1) for 1220-EB			
	4	EH	电热/Heater		SHINI		6kW		230V 50Hz		1	----		(1) for 607-EB			
	5		电热/Heater		SHINI		9kW		230V 50Hz		1	----		(1) for 910-EB			
	6		电热/Heater		SHINI		12kW		230V 50Hz		1	----		(1) for 1220-EB			
	7	H1	蜂鸣器/Buzzer		SHINI		PF-35A		230VAC 50Hz		1	YE84003500000					
B	8	Y1	电磁阀/Solenoid Valve		----		----		230VAC 50/60Hz		1	----		(1)			
	9	Q0	主电源开关/Main power swith		EATON		P1-25/EA/SVB		25A		1	YE10125250000		for 607W-EB			
	10		主电源开关/Main power swith		EATON		P1-32/EA/SVB		32A		1	YE10323200000		for 910W-EB			
	11		主电源开关/Main power swith		EATON		P3-63/EA/SVB		63A		1	YE10636300000		for 1220W-EB			
	12	X1	端子排/Terminal Board		PHOENIX		4.0mm ²		----		3	YE61040000000		for 607W-EB			
	13		接地端子排//Grounding terminal board		PHOENIX		4.0mm ² PE		----		3	YE61043500000		for 607W-EB			
14																	
15																	
C	16																
	17																
	18																
	19																
	20																
	21																
	22																
	23																
24																	
25																	
注: (1)表示非电控箱内材料; (2)表示选配出水 and 回水温度显示功能; Notes: (1)Means it's not the material inside the control box. (2)Means equipped with function of displaying water outlet and return water temperature.																	
D					制图		版号		D		标题		STM-607/910/1220-EB		图号		
					设计		核				元件明细表二		STM-607/910/1220-EB-230V-D-5		比例		
					校对		准						标准		GB		
	标记		更改前		更改后		更改人		日期		审核		日期		20221013		第 5 张
1		2		3		4		5		6		7		8		共 5 张	
																机器电压	
																3/230V	
																机器频率	
																50Hz	



信易电热机械股份有限公司
Shini Plastics Technologies, Inc.

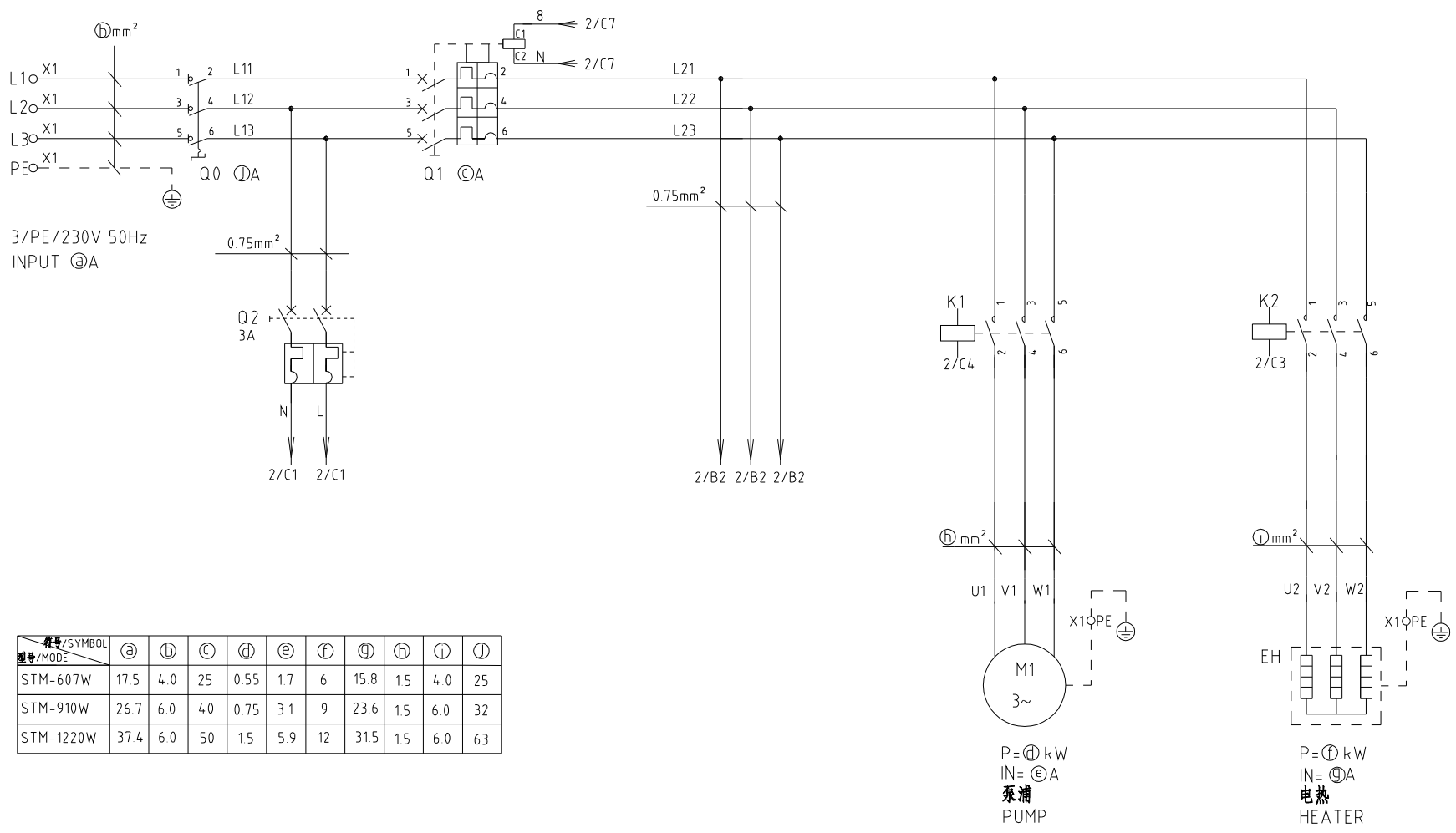

符号/SYMBOL 型号/MODE	ⓐ	ⓑ	ⓒ	ⓓ	ⓔ	ⓕ	ⓖ	ⓗ	ⓘ	ⓙ
STM-607W	17.5	4.0	25	0.55	1.7	6	15.8	1.5	4.0	25
STM-910W	26.7	6.0	40	0.75	3.1	9	23.6	1.5	6.0	32
STM-1220W	37.4	6.0	50	1.5	5.9	12	31.5	1.5	6.0	63

					制图	版号	D	标题	STM-607/910/1220W-EB	图号	STM-607/910/1220W-EB-230V-D-1	比例	第 1 张
					设计	核		主电路图				标准	共 5 张
					校对	准						机器电压	3/230V
标记	更改前	更改后	更改人	日期	审核	日期	20221013					机器频率	50Hz



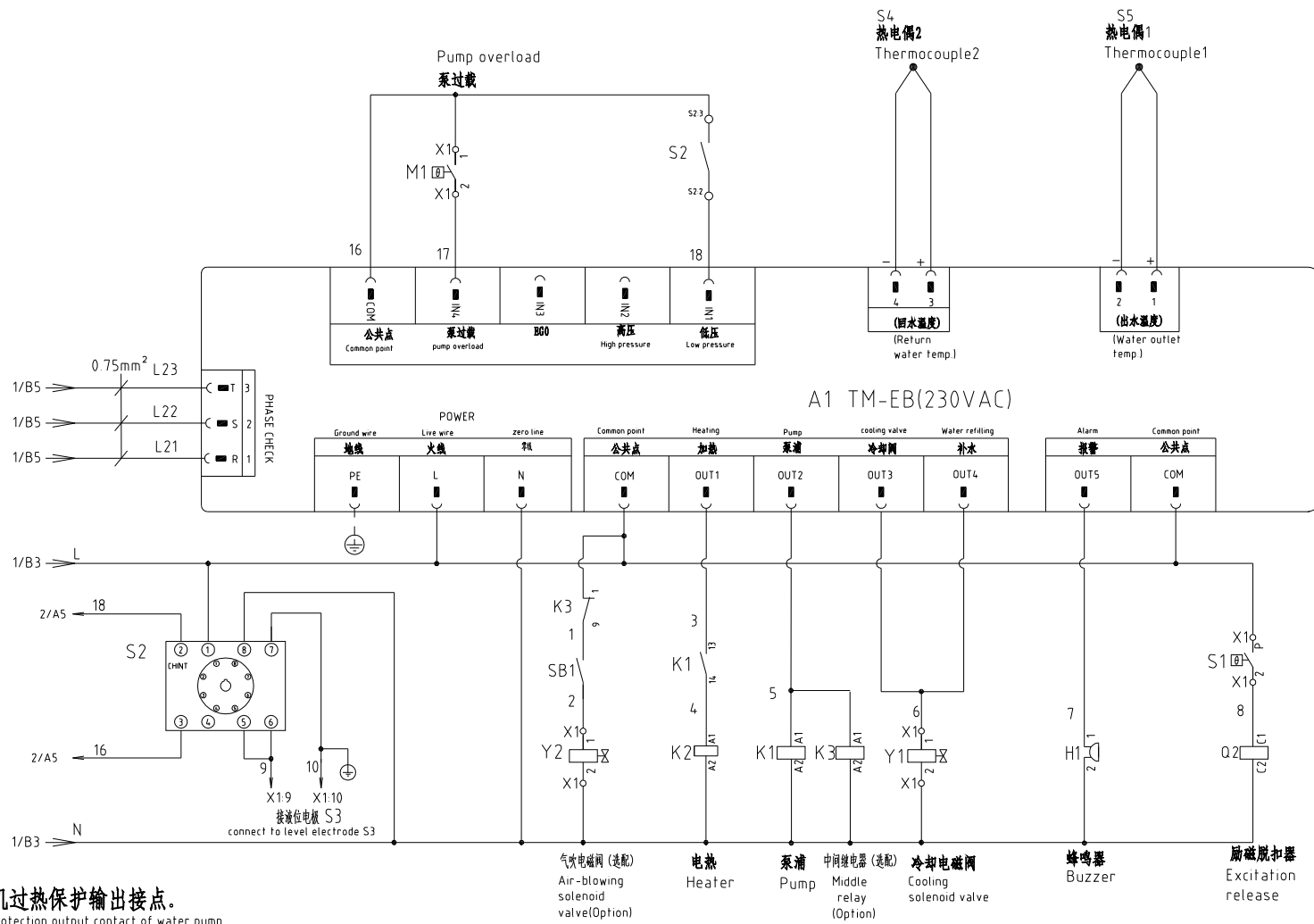

注: M1为水泵电机过热保护输出接点。
 Note: M1 is the overheat protection output contact of water pump.

					制图	版号	D	标题	STM-607/910/1220W-EB	图号	STM-607/910/1220W-EB-230V-D-2	比例	第 2 张
					设计	核		控制电路图		标准	GB	共 5 张	
					校对	准		 信易电热机械股份有限公司 Shini Plastics Technologies, Inc.		机器电压	3/230V		
标记	更改前	更改后	更改人	日期	审核	日期	20221013			机器频率	50Hz		

技术要求: (1) 热电偶正 (+) 负 (-) 极直接接到线路板的热电偶输入端, 不经过端子排。

(2) 电热和泵浦直接接触器输出端。

Technical requirements:

(1) Positive (+) and negative (-) poles of thermocouple should be directly connected to thermocouple's input terminal of circuit board. There is no need for them to go through the terminal board.

(2) the heater and pump directly connect to contactor output.

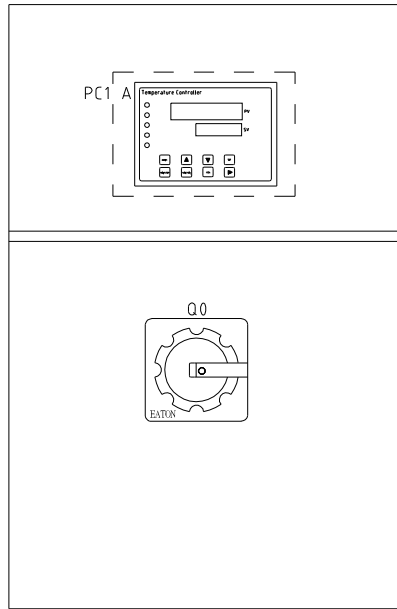

电箱面板
Electric box panel

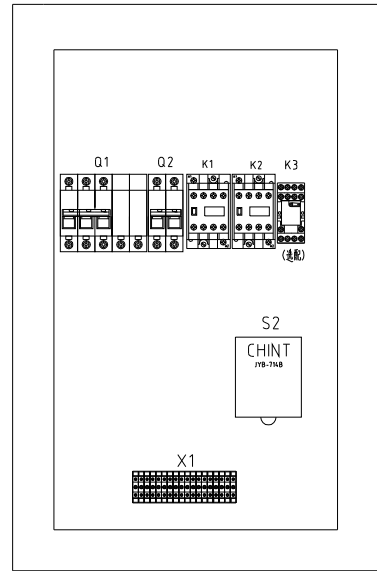

电箱底板
Base plate of electrical box

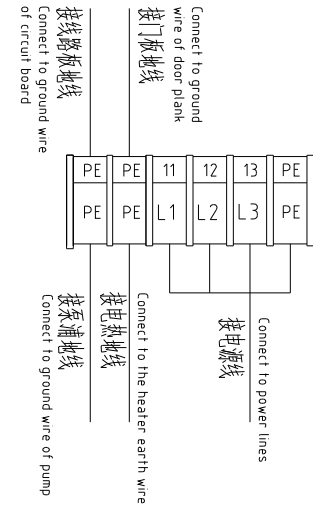
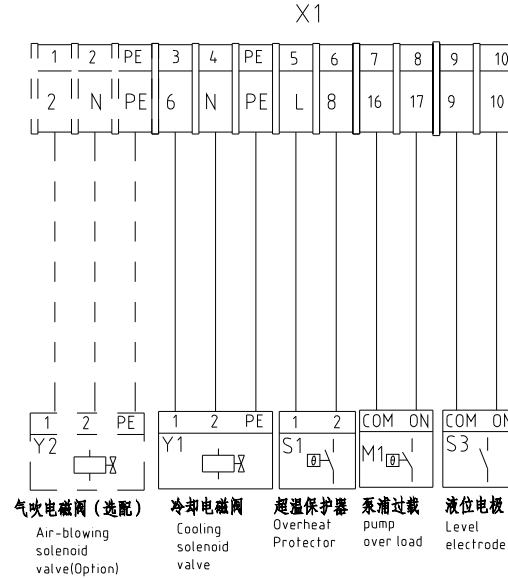

					制图	版号	D
					设计	核准	
					校对		
标记	更改前	更改后	更改人	日期	审核	日期	20221013

标题 STM-607/910/1220W-EB 图号 STM-607/910/1220W-EB-230V-D-3
电气布置及端子接线图



信易电热机械股份有限公司
Shini Plastics Technologies, Inc.

比例	第 3 张
标准 GB	共 5 张
机器电压	3/230V
机器频率	50Hz

1		2		3		4		5		6		7		8		
序号/NO	符号/Symbol	名称/Name		制造商/Manufacturer		型号/Type		规格/Specification		数量/Number	物料编号/Material number		备注/Remark			
A	1	Q1	断路器/Circuit Breakers		TECO		BM-63C		25A		1	YE40302503000		607W-EB用 for 607W-EB		
	2		断路器/Circuit Breakers		TECO		BM-63S		40A		1	YE40304003000		910W-EB用 for 910W-EB		
	3		断路器/Circuit Breakers		TECO		BM-63C/3050S		50A		1	YE40305003000		1220W-EB用 for 1220W-EB		
	4		励磁脱扣器/Excitation release		CHINT		MX		230VAC		1	YE40023560000				
	5	Q2	断路器/Circuit Breakers		TECO		BM-63C/2003S		2P 3A		1	YE40200203000				
	6	K1	接触器/Contactors		SIEMENS		3RT6015-1AN21		220V 50/60Hz		1	YE00601521000				
	7	K2	接触器/Contactors		SIEMENS		3RT6026-1AN20		220V 50/60Hz		1	YE00602622000		607W-EB用 for 607W-EB		
B	8		接触器/Contactors		SIEMENS		3RT6027-1AN20		220V 50/60Hz		1	YE00602722000		910W-EB用 for 910W-EB		
	9		接触器/Contactors		SIEMENS		3RT6028-1AN20		220V 50/60Hz		1	YE00602822000		1220W-EB用 for 1220W-EB		
	10	K3	中间继电器/Middle relay		WEIDMULLER		DRM270730LT		220V 50/60Hz		1	YE03270700000		(2)		
	11	SB1	切换开关/Alternative switch		----		R210-C5LBW4P		220V 50/60Hz		1	YE10210400000		(2)		
	12	A1 TM-EB	线路板/Circuit Board		YUYUN		TM-EB 220VAC 宇韻 YuYun		180~430V 50/60Hz		1	YE81081100100				
	13	H1	蜂鸣器/Buzzer		SHINI		PF-35A		230VAC 50Hz		1	YE84003500000				
	14															
C	15	X1	端子排/Terminal Board		PHOENIX		2.5mm ²		----		8	YE61250040000		607W-EB用 For 607W-EB		
	16		接地端子排/Grounding terminal board		PHOENIX		2.5mm ² PE		----		1	YE61253500000		607W-EB用 for 607W-EB		
	17		端子排/Terminal Board		PHOENIX		2.5mm ²		----		8	YE61250040000		910W-EB用 for 910W-EB		
	18		接地端子排/Grounding terminal board		PHOENIX		2.5mm ² PE		----		1	YE61253500000		910W-EB用 for 910W-EB		
	19		端子排/Terminal Board		PHOENIX		6mm ²		----		3	YE61060000000		910W-EB用 for 910W-EB		
	20		接地端子排/Grounding terminal board		PHOENIX		6mm ² PE		----		3	YE61063500000		910W-EB用 for 910W-EB		
	21		端子排/Terminal Board		PHOENIX		2.5mm ²		----		8	YE61250040000		1220W-EB用 for 1220W-EB		
	22		接地端子排/Grounding terminal board		PHOENIX		2.5mm ² PE		----		1	YE61253500000		1220W-EB用 for 1220W-EB		
	23		端子排/Terminal Board		PHOENIX		6mm ²		----		3	YE61060000000		1220W-EB用 for 1220W-EB		
	24		接地端子排/Grounding terminal board		----		6mm ² PE		----		3	YE61063500000		1220W-EB用 for 1220W-EB		
25																
注: (1)表示非电控箱内材料; (2)表示气吹功能选配件; (3)表示选配出水 and 回水温度显示功能; Notes: (1)Means it's not the material inside the control box. (2)Means it is optional with air-blowing function. (3)Means equipped with function of displaying water outlet and return water temperature.																
D					制图		版号		D		标题		STM-607/910/1220W-EB		图号	
					设计		核				STM-607/910/1220W-EB-230V-D-4		比例		第 4 张	
					校对		准				元件明细表一		标准		GB 共 5 张	
	标记		更改前		更改后		更改人		日期		20221013		 信易电热机械股份有限公司 Shini Plastics Technologies, Inc.		机器电压 3/230V 机器频率 50Hz	
1		2		3		4		5		6		7		8		

1	2	3	4	5	6	7	8	
序号/NO	符号/Symbol	名称/Name	制造商/Manufacturer	型号/Type	规格/Specification	数量/Number	物料编号/Material number	备注/Remark
A	M1	马达/Motor	SHINI	TP-55	230V 50Hz 0.55kW	1	----	(1) 607W-EB用 for 607W-EB
		马达/Motor	SHINI	TP-75	230V 50Hz 0.75kW	1	----	(1) 910W-EB用 for 910W-EB
		马达/Motor	SHINI	TP-150	230V 50Hz 1.5kW	1	----	(1) 1220W-EB用 for 1220W-EB
	EH	电热/Heater	SHINI	6kW	230V 50Hz	1	----	(1) 607W-EB用 for 607W-EB
		电热/Heater	SHINI	9kW	230V 50Hz	1	----	(1) 910W-EB用 for 910W-EB
		电热/Heater	SHINI	12kW	230V 50Hz	1	----	(1) 1220W-EB用 for 1220W-EB
	S1	突跳式超温保护器/Snap action overheat protector	----	KSD301-12.5/10BL16K20	125℃	1	YE90030100000	(1)
B	S2	液位控制器/Level controller	CHINT	JYB-714B	230VAC 50/60Hz	1	YE03071400000	(1)
	S3	液位电极/Level electrode	----	----	----	1	YE90815970000	(1)
	S4	热电偶/Thermocouple	SHINI	----	K	1	----	(1) (3)
		热电偶/Thermocouple	SHINI	----	K	1	----	(1) (3)
	Y1	电磁阀/Solenoid Valve	----	----	230VAC 50/60Hz	1	----	(1)
	Y2	电磁阀/Solenoid Valve	----	----	230VAC 50/60Hz	1	----	(1) (2)
	X1	端子排/Terminal Board	PHOENIX	2.5mm ²	----	2	YE61250040000	(2)
		接地端子排/Grounding terminal board	PHOENIX	2.5mm ² PE	----	1	YE61253500000	(2)
C	X1	端子排/Terminal Board	PHOENIX	4.0mm ²	----	3	YE61040000000	607W-EB用 for 607W-EB
		接地端子排/Grounding terminal board	PHOENIX	4.0mm ² PE	----	3	YE61043500000	607W-EB用 for 607W-EB
	Q0	主电源开关/Main power switch	EATON	P1-25/EA/SVB	25A	1	YE10125250000	607W-EB用 for 607W-EB
		主电源开关/Main power switch	EATON	P1-32/EA/SVB	32A	1	YE10323200000	910W-EB用 for 910W-EB
		主电源开关/Main power switch	EATON	P3-63/EA/SVB	63A	1	YE10636300000	1220W-EB用 for 1220W-EB
	24							
	25							

注: (1)表示非电控箱内材料; (2)表示气吹功能选配件; (3)表示选配出水 and 回水温度显示功能;
Notes: (1)Means it's not the material inside the control box. (2)Means it is optional with air-blowing function. (3)Means equipped with function of displaying water outlet and return water temperature.

D						制图	版号	D	标题	STM-607/910/1220W-EB	图号	STM-607/910/1220W-EB-230V-D-5	比例	第 5 张	
						设计	核		元件明细表二		标准	GB	共 5 张		
						校对	准		 信易電熱機械股份有限公司 Shini Plastics Technologies, Inc.		机器电压	3/230V			
	标记	更改前	更改后	更改人	日期	审核	日期	20221013			机器频率	50Hz			
1		2		3		4		5		6		7		8	