

SDD Series

Dehumidifying Dryer

Date: Dec. 2017

Version: Ver.F (English)



Contents

1. General Description	7
1.1 Coding Principle.....	8
1.2 Feature	8
1.3 Technical Specifications	10
1.3.1 Outline Drawing.....	10
1.3.2 Specifications	10
1.3.3 Drying Capacity	11
1.4 Safety Regulations.....	13
1.4.1 Safety Regulations for the Blowers	13
1.4.2 Safety Signs and Labels.....	14
1.4.3 Signs and Labels.....	15
1.4.4 Transportation and Storage of the Machine	15
1.5 Exemption Clause.....	16
2. Structure Characteristics and Working Principle.....	17
2.1 Working Principle	17
2.2 Relative Humidity and Dew-point.....	17
2.3 Why Choose SDD.....	18
2.4 Options	19
3. Installation Testing.....	20
3.1 Machine Location.....	20
3.2 Power Connectors	20
3.3 Air pipe and material pipe connection.....	21
3.4 Water connections	21
3.4.1 Cooling Water Connection.....	22
3.4.2 Condensation Drainage Pipe.....	23
3.5 Cyclone Dust Collector	23
3.6 Oil Filter	24
3.7 Plate Heat Exchanger	25
4. Application and Operation.....	26
4.1 Operation Procedure for HMI.....	26

4.1.1	System Initialization screen.....	26
4.1.2	Dehumidification and Drying Monitor Page	27
4.1.2.1	Drying Temperature Modification	27
4.1.2.2	Start-up and Shutdown	27
4.1.3	User Menu Screen	28
4.1.3.1	Timer Setting	29
4.1.3.1.1	System Time Setting.....	29
4.1.3.1.2	Weekly Timer Setting.....	30
4.1.3.2	Multilingual Setting.....	30
4.1.4	Alarm Message Checking.....	31
4.1.5	Project Setting.....	32
5.	Trouble-shooting.....	35
6.	Maintenance and Repair	41
6.1	The Useful Life of the Key Parts of the Product	42
6.2	Filter	42
6.3	Honeycomb-rotor	43
6.3.1	What is Honeycomb-rotor.....	43
6.3.2	Installation of the Rotor	43
6.3.3	Honeycomb Rotor Cleaning Steps	44
6.4	EGO.....	45
6.5	Cooler Clear Step	45
6.6	Dewpoint Monitor (Option)	46
6.6.1	Installation for Dewpoint Monitor	46
6.6.2	Dew-point Monitor Setting	48
6.7	Maintenance Schedule	50
6.7.1	General Machine Information	50
6.7.2	Check after Installation.....	50
6.7.3	Daily Checking	50
6.7.4	Weekly Checking.....	50
6.7.5	Monthly Checking.....	51
6.7.6	Half-yearly Checking	51
6.7.7	Yearly Checking	51
6.7.8	3 year Checking	51

Table Index

Table 1-1: Specifications	10
Table 1-2: Drying Capacity 1	11
Table 1-3: Drying Capacity 2	12
Table 4-1: Project Setting Parameters	34
Table 6-1: The useful life of the key parts of the product.....	42

Picture Index

Picture 1-1: Outline Drawing.....	10
Picture 1-2: Safety Regulations for the Blowers	14
Picture 2-1: Working Principle	17
Picture 3-1: Installation Drawing.....	20
Picture 3-2: Air Pipe and Material Pipe Connection Drawing.....	21
Picture 3-3: Cooling Water Connection	22
Picture 3-4: Installation Dia. of Cyclone Dust Collector	23
Picture 3-5: Installation Dia. of Oil Filter	24
Picture 3-6: Plate Heat Exchanger Figure	25
Picture 4-1: Description of Touch Panel	26
Fig. 4-2: System Initialization Screen.....	26
Fig. 4-3: Drying Monitoring Screen	27
Fig. 4-4 Drying Temp. Modification Screen	27
Fig. 4-5: Start-up and Shutdown Screen.....	28
Fig. 4-6: User Meun Screen.....	28
Fig. 4-7: User Menu Time Setting Screen.....	29
Fig. 4-8: System Time Setting.....	29
Fig. 4-9: WSET Screen	30
Fig. 4-10: Multilingual Setting Screen	30
Fig. 4-11: Alarm Message Screen	31
Fig. 4-12: Alarm History Screen	31
Fig. 4-13: Project Password Setting Screen	32

Fig. 4-14: Project Setting Screen	32
Fig. 4-15: Project General Setting Screen	33
Fig. 4-16: Project Detection Time Setting Screen	33
Fig. 4-17: Password Modification Setting Screen	33
Picture 6-1: Filter	42
Picture 6-2: Honeycomb Rotor	43
Picture 6-3: Installation of The Rotor	44
Picture 6-4: EGO	45
Picture 6-5: Hole Site.....	46
Picture 6-6: Parts of Dew-point Monitor.....	46
Picture 6-7: Copper Joint Assembly of Original Machine.....	47
Picture 6-8: Installation Seat.....	47
Picture 6-9: Installation for Transmitter.....	47
Picture 6-10: Connection of Signal Wire.....	48
Picture 6-11: Connection of Dew-point Monitor	48

1. General Description



Please read through this operation manual before using the machine to prevent damages of the machine or personal injuries.

SDD series dehumidifying dryer combine dehumidifying and drying systems into a single unit. They have many applications in processing plastic materials, such as PA, PC, PBT, PET etc. All models feature SD-H honeycomb dehumidifiers with built-in process heater and insulated drying hopper. Under ideal conditions, it can provide dehumidified dry air with a dew-point lower than -40°C .



SDD-80U/40H

1.1 Coding Principle

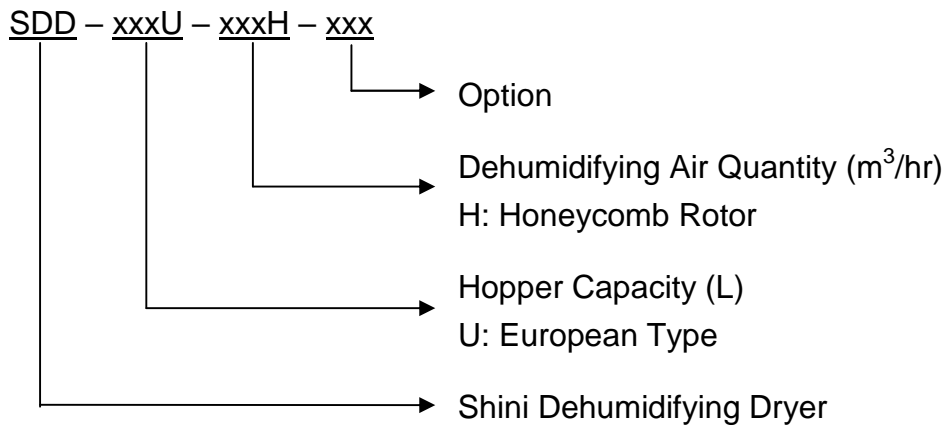

1.2 Feature

- The SDD dehumidifying dryer use honeycomb dehumidifiers with an eye-catching semi-integral appearance.
- Each model combines dehumidifying and drying functions into a single unit.
- Insulated drying hopper features dry air down-blowing and cyclone exhaust design. This improves drying efficiency and reduces energy consumption while maintain a steady drying effect.
- The dehumidifying section of the SDD series features two coolers to ensure a low return air temperature and low dew-point.
- Compact in size for ease of movement and space saving.
- Microprocessor is the standard equipment.

All service work should be carried out by a person with technical training or corresponding professional experience. The manual contains instructions for both handling and servicing. Chapter 6, which contains service instructions intended for service engineers. Other chapters contain instructions for the daily operator.

Any modifications of the machine must be approved by SHINI in order to avoid personal injury and damage to machine. We shall not be liable for any damage caused by unauthorized change of the machine.

Our company provides excellent after-sales service. Should you have any problem during using the machine, please contact the company or the local vendor.

Headquarter and Taipei factory:

Tel: (886) 2 2680 9119

Shini Plastics Technologies (Dongguan), Inc:

Tel: (86) 769 8111 6600

Shini Plastics Technologies India Pvt.Ltd.:

Tel: (91) 250 3021 166

1.3 Technical Specifications

1.3.1 Outline Drawing

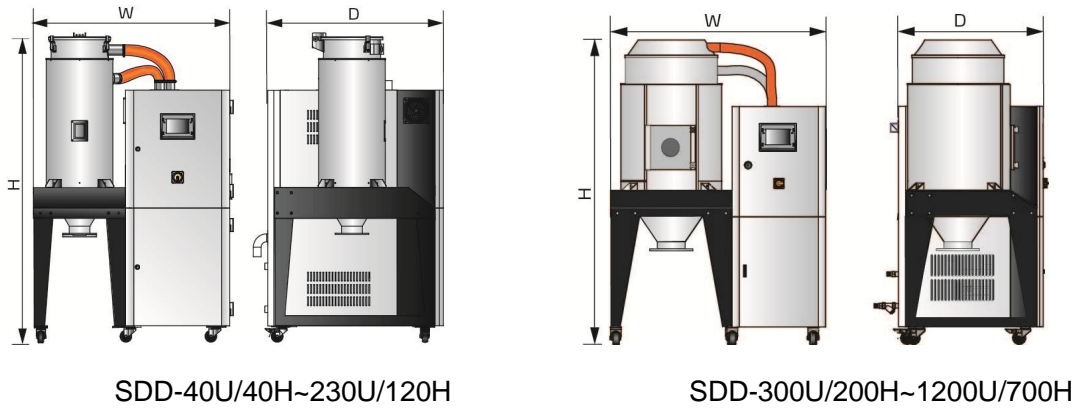

Picture 1-1: Outline Drawing

1.3.2 Specifications

Table 1-1: Specifications

Model-SDD	Ver.	Regen. Heater (kW) (50/60Hz)	Regen. Blower (kW) (50/60Hz)	Drying Heater (kW)	Drying Blower (kW) (50/60Hz)	Dry Air Volume (m ³ /hr) (50/60Hz)	Insulated Hopper (L)	Dimension (mm) H×W×D	Weight (kg)
40U/40H	E	3 / 3	0.12 / 0.12	4	0.12 / 0.18	40 / 45	40	1509×978×931	165
80U/40H	E	3 / 3	0.12 / 0.12	4	0.12 / 0.18	40 / 45	80	1796×1060×1030	190
120U/120H	A	4 / 4	0.4	6	0.75	120	120	1817×1060×893	250
160U/120H	D	4 / 4	0.4	6	0.75	120	160	2070×1060×893	265
230U/120H	D	4 / 4	0.4	6	0.75	120	230	2052×1210×893	295
300U/200H	D	4 / 6	0.4	12	1.5	200	300	2040×1450×1050	420
450U/200H	D	4 / 6	0.4	12	1.5	200	450	2440×1450×1050	550
600U/400H	C	7.2 / -	0.75	18	3.75	400	600	2380×1745×1255	620
750U/400H	C	7.2 / -	0.75	18	3.75	400	750	2610×1745×1255	650
900U/700H	D	10 / -	1.5	24	7.5	700	900	2640×2140×1380	830
1200U/700H	F	10 / -	1.5	24	7.5	700	1200	3070×2140×1380	870

Note: 1) Plastic materials can be fully dried by drying air with dew-point temperature $\leq -20^{\circ}\text{C}$. When ambient temperature $\leq -25^{\circ}\text{C}$ and relative humidity $\leq 60\%$, the drying air dewpoint temp. $\leq -40^{\circ}\text{C}$.

2) Power: 3 Φ , 230 / 400 / 460 / 575VAC, 50 / 60Hz.

We reserve the right to change specifications without prior notice.

1.3.3 Drying Capacity

Table 1-2: Drying Capacity 1

Material	Drying Temp. (°C)	Drying Time (hr)	Drying Capacity (kg/hr)					
			40U /40H	80U /40H	120U /120H	160U /120H	230U /120H	300U /200H
ABS	80	2-3	16	18	27	35	105	
CA	75	2-3	12	15	22	29	90	
CAB	75	2-3	12	15	22	29	90	
CP	75	2-3	16	18	27	35	106	
LCP	150	4	11	13	40	27	80	
POM	100	2	24	27	40	53	160	
PMMA	80	3	17	19	29	38	115	
IONOMER	90	3-4	10	11	17	22	66	
PA6/6.6/6.10	75	4-6	9	10	14	19	58	
PA11	75	4-5	10	11	17	23	69	
PA12	75	4-5	10	12	17	23	69	
PC	120	2-3	18	21	31	41	124	
PU	90	2-3	17	19	29	38	115	
PBT	130	3-4	13	15	23	31	93	
PE	90	1	47	53	80	106	318	
PEI	150	3-4	11	13	20	27	80	
PET	160	4-6	11	13	19	25	75	
PETG	70	3-4	11	13	20	27	80	
PEN	170	5	13	15	23	30	90	
PES	150	4	13	15	23	30	90	
PPO	110	1-2	19	22	33	44	133	
PPS	150	3-4	11	13	20	27	80	
PI	120	2	24	27	40	53	160	
PP	90	1	39	44	66	88	265	
PS(GP)	80	1	39	44	66	88	265	
PSU	120	3-4	12	14	22	29	86	
PVC	70	1-2	19	22	33	44	133	
SAN(AS)	80	1-2	19	22	33	44	133	
TPE	110	3	18	21	31	41	124	

Note: 1. Please refer to above drying capacity of SCD machine, select the right model according to material usage of processing machine.

2. Specific model selection, please consult the letter easy service personnel.

Table 1-3: Drying Capacity 2

Material	Drying Temp. (°C)	Drying Time (hr)	Drying Capacity (kg/hr)			
			600U /400H	750U /400H	900U /700H	1200U /700H
ABS	80	2-3	210		355	
CA	75	2-3	180		295	
CAB	75	2-3	180		295	
CP	75	2-3	210		355	
LCP	150	4	160		365	
POM	100	2	320		530	
PMMA	80	3	230		383	
IONOMER	90	3-4	133		220	
PA6/6.6/6.10	75	4-6	115		192	
PA11	75	4-5	138		230	
PA12	75	4-5	138		230	
PC	120	2-3	250		413	
PU	90	2-3	230		383	
PBT	130	3-4	186		310	
PE	90	1	637		1062	
PEI	150	3-4	160		265	
PET	160	4-6	150		250	
PETG	70	3-4	160		265	
PEN	170	5	180		300	
PES	150	4	180		300	
PPO	110	1-2	265		440	
PPS	150	3-4	160		265	
PI	120	2	320		530	
PP	90	1	530		885	
PS(GP)	80	1	531		885	
PSU	120	3-4	173		290	
PVC	70	1-2	265		442	
SAN(AS)	80	1-2	265		442	
TPE	110	3	250		413	

Note: 1. Please refer to above drying capacity of SCD machine, select the right model according to material usage of processing machine.

2. Specific model selection, please consult the letter easy service personnel.

1.4 Safety Regulations



Warning!

Electrical installation should be done by qualified technician only.

Before connecting to AC Power Source, turn power switch to OFF position.

While AC power source is connected, make sure specifications and overload protection rating of the power switch are suitable and reliable.

When the machine is under care or maintenance status, turn both power switch and automatic operation switch to off.

1.4.1 Safety Regulations for the Blowers

- 1) Under normal operation, the blowers will generate high temperature. Do not touch blower's case to avoid any physical injury.
- 2) Under normal operation, the blower motor's current loading will increase or reduce according to air pressure's change accordingly. While installation, an adequate motor overload protection switch should be installed with full loading test, to ensure operating safely under full-loading to avoid motor's damage.
- 3) To avoid any block materials, dust, powder, fiber particles and water drops entering the blower, and hence cause the deficiency of its performance. This machine is well designed with air filters, so please clean up the filter with any foreign particles (recommended to clean up this filter weekly).
- 4) Clean the blowers both internal and external parts (especially for the fan cooling path), and remove surface dust if necessary. If more dusts are accumulated, it will cause deficiency for ventilation, temperature rising, vacuum power reduced, vibration increased and so it will cause machine broke down.
- 5) Ball bearing, oil seal and soundproof are belonging to consumable parts and so it has a life period and requires regular replacement. Meanwhile, blade, external case, and metallic screen etc. should be replaced regularly for best performance.
- 6) Under normal operation, if the blowers are not running smoothly or abnormal noise appeared. Please immediately shut down the machine for repair.
- 7) Don't manual discharge material inside the hopper while its not or opening cleaning door while the material is not.

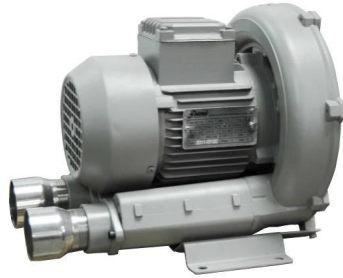

Picture 1-2: Safety Regulations for the Blowers

1.4.2 Safety Signs and Labels



Danger!

High voltage danger!

This label is stuck on the electrical boxes.



Attention!

This label means that this area should be taken care!



Warning!

High temperature, take care of hands!



This label should be stick to the shell of heater.



Attention!

No need for regular inspection because all the electrical parts in the control unit are fixed tightly!

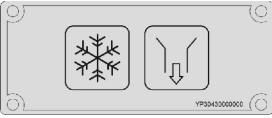
1.4.3 Signs and Labels

	<p>Hot surfaces can burn hands.</p>
	<p>Water outlet: drainage outlet.</p>
	<p>Water inlet: inlet for replenishing water and cooling water.</p>
	<p>Push-and-pull switch for shut-off plate: I: Means "Pull" O: Means "Push"</p>

1.4.4 Transportation and Storage of the Machine

Transportation

- 1) SDD series dehumidifying dryer are packed in crates or plywood cases with wooden pallet at the bottom, suitable for quick positioning by fork lift.
- 2) After unpacked, castors equipped on the machine can be used for ease of movement.
- 3) Do not rotate the machine and avoid collision with other objects during transportation to prevent improper functioning.
- 4) The structure of the machine is well-balanced, although it should also be handled with care when lifting the machine for fear of falling down.
- 5) The machine and its attached parts can be kept at a temperature from -25°C to $+55^{\circ}\text{C}$ for long distance transportation and for a short distance, it can be transported with temperature under $+70^{\circ}\text{C}$.

Storage

- 1) SDD series dehumidifying dryer should be stored indoors with temperature kept from 5°C to 40°C and humidity below 80%.
- 2) Disconnect all power supply and turn off main switch and control switch.
- 3) Keep the whole machine, especially the electrical components away from water to avoid potential troubles caused by the water.
- 4) Plastic film should be used to protect the machine from dust and rains.

Working environment

Indoors in a dry environment with max. temperature +45°C and humidity no more than 80%.

Do not use the machine

- 1) If it is with a damaged cord.
- 2) On a wet floor or when it is exposed to rain to avoid electrical shock.
- 3) If it has been dropped or damaged until it is checked or fixed by a qualified serviceman.
- 4) This equipment works normally in the environment with altitude within 3000m.
- 5) At least a clearance of 1m surrounding the equipment is required during operation. Keep this equipment away from flammable sources at least two meters.
- 6) Avoid vibration, magnetic disturbance at the operation area.

Rejected parts disposal

When the equipment has run out its life time and can not be used any more, unplug the power supply and dispose of it properly according to local code.

Fire hazard



In case of fire, CO₂ dry powder fire extinguisher should be applied.

1.5 Exemption Clause

The following statements clarify the responsibilities and regulations born by any buyer or user who purchases products and accessories from Shini (including employees and agents).

Shini is exempted from liability for any costs, fees, claims and losses caused by reasons below:

1. Any careless or man-made installations, operation and maintenances upon machines without referring to the Manual prior to machine using.
2. Any incidents beyond human reasonable controls, which include man-made vicious or deliberate damages or abnormal power, and machine faults caused by irresistible natural disasters including fire, flood, storm and earthquake.
3. Any operational actions that are not authorized by Shini upon machine, including adding or replacing accessories, dismantling, delivering or repairing.
4. Employing consumables or oil media that are not appointed by Shini.

2. Structure Characteristics and Working Principle

2.1 Working Principle

Moisture hot air from drying hopper is blown into rotor after flowing through cooler. Moisture from the air is dried by rotor and is then adsorbed by regeneration heating air. Two strands of airflow function on the rotor. And with the rotation, moisture from the air is absorbed and expelled after absorbed regeneration air to form stable low dew-point air, which is dried and heated to the drying temperature and then is blown into material barrel to closed circle to dry material.

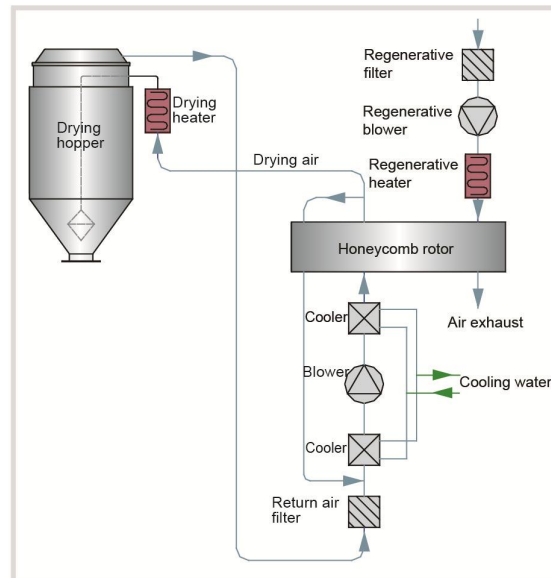

Picture 2-1: Working Principle

2.2 Relative Humidity and Dew-point

Relative humidity: Relative air humidity means real vapor content to saturated vapor at the same temperature in percentage.

Dew point: it means that temperature when the saturation vapor begins to dew. When the relative humidity is 100%, the ambient temperature is the dew point temperature. The more lower of dew point temperature (than the ambient temperature) is, the more less possible to dew, that also means the more drier the air is. The dew point will not be influenced by temperature, but influenced by pressure.

2.3 Why Choose SDD

For these quality deficiencies as bubble, crazing, cracking, poor transparency are due to insufficient drying of plastic materials before molding, and the engineering plastics such as: PC, PA, PBT, PET, Nylon, etc. The hygroscopic materials used in the plastics industry such as PC, PA, PBT, PET, Nylon, etc. cannot be dried effectively by conventional hot air drying systems because the moisture enters inside the particles. According to suggestion of the manufacturer, the plastic materials can be completely dried by drying air with dew-point temperature ≤ -20 °C . However, the SCD sufficiently dehumidifies and dries the air inside the closed-loop system, and the dry air eliminates the moisture fast and completely as to reach the drying and dehumidifying effect.

2.4 Options

- Built-in type, which means that dew-point monitor is installed on the machine, is convenient to monitor dew-point temperature. Add "D" at the end of the model code.
- Portable type, which means that dew-point monitor is separate from the machine, is convenient to test dew-point temperature of different machines. Add "PD" at the end of the model code.



Dew-point Monitor (portable)

- For models optional with dew-point control, add "DC" at model behind. "ES" by setting if dew-point value to control the regeneration required temperature automatically and lowers power consumption of the regenerative heater; According to $-40^{\circ}\text{C}\sim+10^{\circ}\text{C}$ of dew-point value, the total power consumption can save 0~10%.
- For models with energy-saving drying management, add "ES" at model behind, standard equipped with HMI touch control, which can save up to 41% of total power consumption. Volume used per hour is settable between 40~100% as drying capacity to save the totally power consumption of 35%~0; Standard equipped with heat regenerative recycler which recycles the regeneration air exhausted heat via plate heat exchanger and can save 3%~6% of total power consumption.
- For models optional with drying heat recycler, add "HE" at model behind. Dehumidified low temperature air via plate heat exchanger to recycle the heat of hot-wet return air, which can higher the air temperature in drying heater and lower the power consumption of the heater, the total power consumption can save 0%~19%.
- For models with hopper polished inside, at "P" at the end of the mode code.

3. Installation Testing

This series of models only could be applied in working environment with good ventilation.

3.1 Machine Location



Picture 3-1: Installation Drawing

Installation Notice:

- 1) The machine can only be installed in the vertical position, make sure there's no pipeline, fixed structure and other object which may obstruct machine installation or cause items, human injuries above the selected location and adjacent areas.
- 2) For easy maintenance, leaving 1m space around machine is suggested. Keep machine 2m away from the inflammable materials.
- 3) The machine must be placed on the ground level to ensure balance state, and to remove the accumulated condensing water. If machine is need to install on a higher level (scaffolding or interlayer), it should make sure that the structure and size could withstand the machine.

3.2 Power Connectors

- 1) Make sure voltage and frequency of the power source comply with those indicated on the manufacturer nameplate, which is attached to the machine.
- 2) Power cable and earth connections should conform to your local regulations.
- 3) Use independent power cable and ON/OFF switch. The cable's size should not smaller than those wired in the electrical requirement of control panel.

- 4) The power cable connection terminals should be tightened securely.
- 5) The machine requires a 3-phase 4-wire power source, connect the power lead (L1, L2, L3) to the live wires, and the earth (PE) to the ground.
- 6) Power supply requirements:
 Main power voltage: $\pm 5\%$
 Main power frequency: $\pm 5\%$
- 7) Refer to the electrical wiring diagram to complete the electrical installation.

3.3 Air pipe and material pipe connection

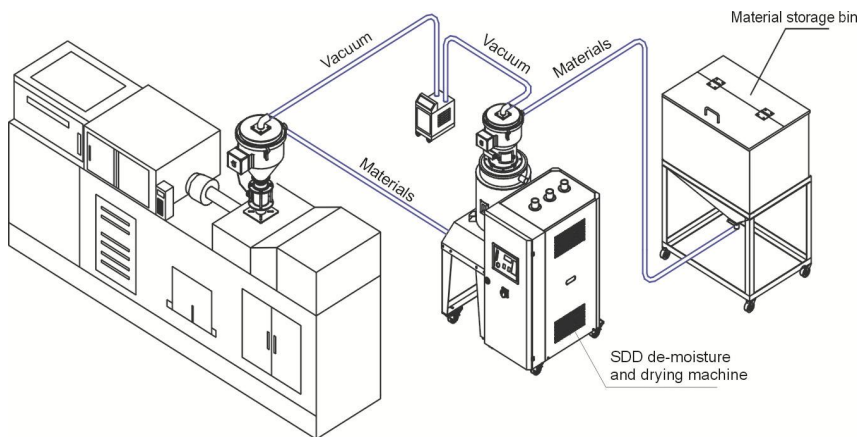

Picture 3-2: Air Pipe and Material Pipe Connection Drawing

3.4 Water connections

The cooling water pressure is 3~5bar and the cooling water temperature should be 10~30°C.

	<p>Water outlet: cooling water outlet.</p>
	<p>Water inlet: inlet for replenishing water and cooling water.</p>

cooling water needs to be connected the before operation. The water port is at the back of the machine.

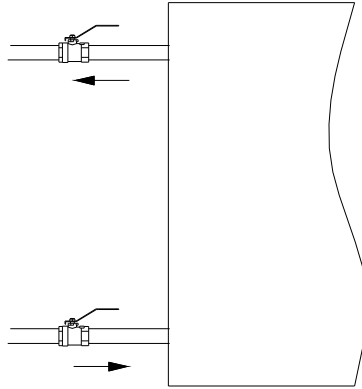

Picture 3-3: Cooling Water Connection

3.4.1 Cooling Water Connection

Connect through the cooling water before machine operation. For the efficiency, please follow below suggestions:

- 1) For easy maintenance and safety, install the ball valve at cooling water inlet and outlet.
- 2) Water pipe diameter should not less than the diameter of cooling water inlet and outlet.
- 3) For water quality, it needs to sediment or filter the water before it gets into the pipe, to prevent the deposits accumulated on pipeline of cooler and performance degradation.

Cooling Water Specifications			
Model	Flowrate of Cooling Water (L/min)	Model	Flowrate of cooling Water (L/min)
30H	4	400H	50
40H	5	500H	60
50H	6	700H	80
80H	10	1000H	120
120H	15	1500H	180
150H	20	2000H	240
200H	30	3000H	360
300H	40	4000H	480

Note: 1. Difference in temperature: 5°C
 2. Cooling water pressure: 3~5Kgf/cm²

3.4.2 Condensation Drainage Pipe

During normal operation, it will generate condensation water. Connect the water pipe at drainage outlet to remove the condensation water is necessary.

- 1) Drainage pipe inner diameter should not less than the diameter of drainage outlet.
- 2) Drainage pipe should be long enough to approach the drainage channel, and be the hose. Be careful not to press or bend the pipe for smooth water flow (Use the rigid pipe if there's need to press or bend the hose).
- 3) As condensation water drainage is in terms of gravity, make sure the drainage outlet is above the pipe. Otherwise the water can't be drained out and will flow back to the machine.

3.5 Cyclone Dust Collector

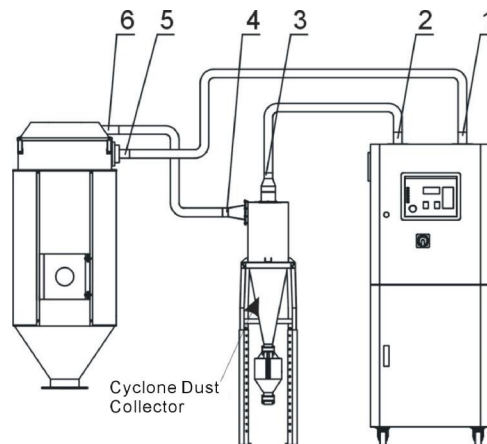

Picture 3-4: Installation Dia. of Cyclone Dust Collector

Cyclone Dust Collector Installation Steps:

1. Connect 1 and 5 with a heat-resistant duct and fixed both the ends with stainless steel tube.
2. Connect 2 and 3 with a heat-resistant duct and fixed both the ends with stainless steel tube.
3. Connect 4 and 6 with a heat-resistant duct and fixed both the ends with stainless steel tube.

3.6 Oil Filter

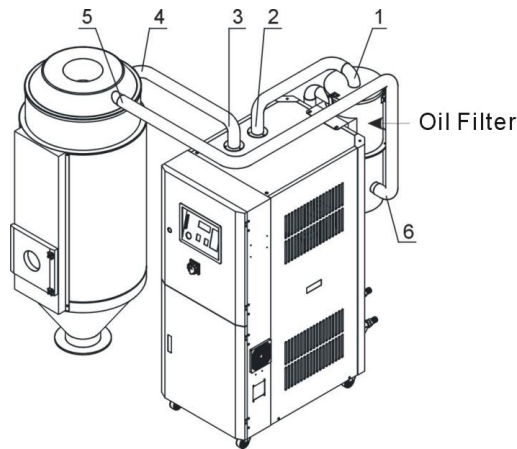

Picture 3-5: Installation Dia. of Oil Filter

Oil Filter Installation Steps:

1. Screw the oil filter on the top plate of the honeycomb dehumidifier.
2. Connect 1 and 2 with a heat-resistant duct and fixed both the ends with stainless steel tube.
3. Connect 3 and 4 with a heat-resistant duct and fixed both the ends with stainless steel tube.
4. Connect 5 and 6 with a heat-resistant duct and fixed both the ends with stainless steel tube.

3.7 Plate Heat Exchanger

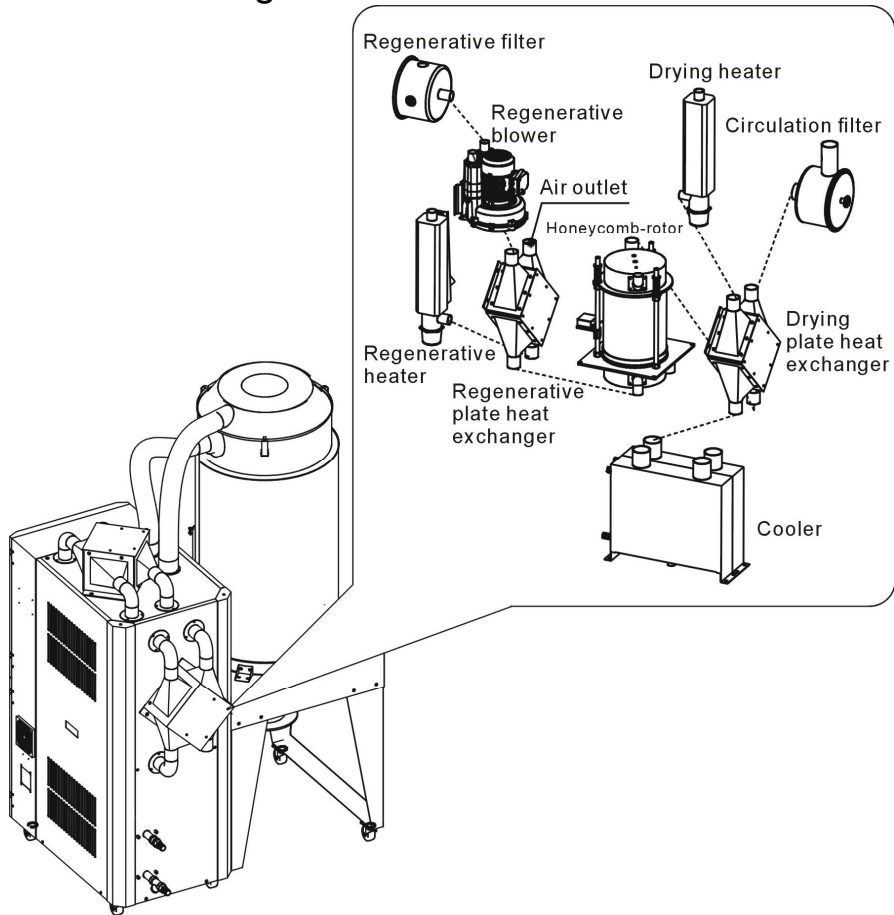

Picture 3-6: Plate Heat Exchanger Figure

Each part is connected by heat-resistant air pipes and fixed by stainless steel pipes as shown in the diagram.

4. Application and Operation

4.1 Operation Procedure for HMI



Picture 4-1: Description of Touch Panel

Operation Notice:

- 1) Avoid violent collision of the touch screen when operating it.
- 2) In dry environment, static electricity may be produced on the touch screen, so a metal wire is needed to discharge it before operating.
- 3) Use alcohol or eleoptene to clean the touch screen, because other solvents may fade it.
- 4) Do not tear down the touch screen or take away any PCB from it. Otherwise, the component will be damaged.

4.1.1 System Initialization screen

After the system is powered on, the touch penal displays initial page. As below figure:



Fig. 4-2: System Initialization Screen

4.1.2 Dehumidification and Drying Monitor Page

After a few seconds of countdown, the system initialization interface will enter the dehumidification and drying monitoring screen, as below figure:

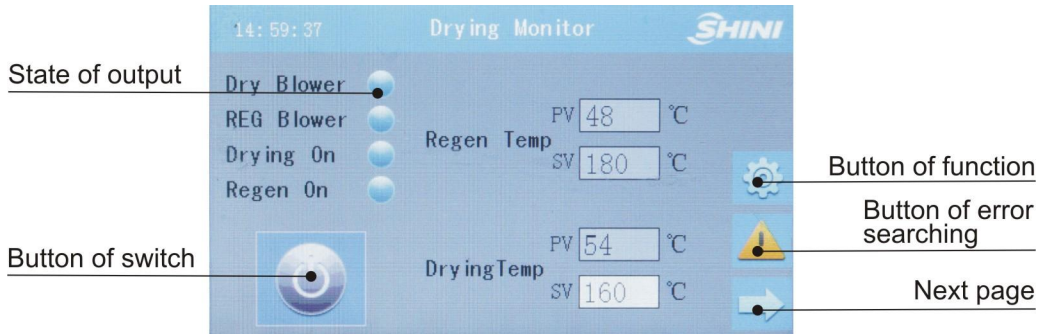

Fig. 4-3: Drying Monitoring Screen

4.1.2.1 Drying Temperature Modification

Directly click the <SV> of drying temperature, and the numerical keypad will pop up. Input the requested drying temperature and then press <ENTER> to confirm.

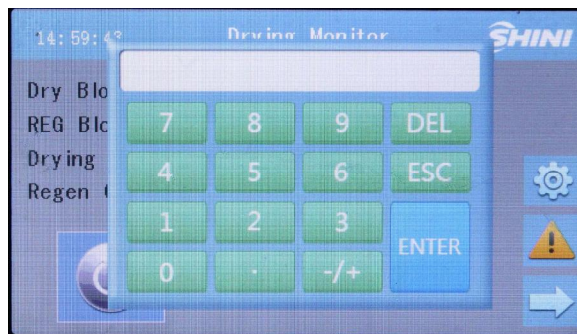

Fig. 4-4 Drying Temp. Modification Screen

Note: The drying and regenerating temperatures all have the maximum and minimum values. The default setting of regenerating temperature is set to 180 °C . No resetting is permitted without permission!

4.1.2.2 Start-up and Shutdown

Press once the <Button of Switch> on Drying Monitoring screen to start machine, and press once again the <Button of Switch> to stop the machine. Then, click

<Button of Switch> to make it turn grey, the system stops operation.

Note: in order to prolong the life of honeycomb-rotor, never stop the machine by cutting down the main power supply directly, you should turn off the machine by pressing <Button of Switch> firstly. The later operation ensures honeycomb-rotor continuously run for a delaying time to cool down the rotor. This rotating time always is 3 minutes. After the delaying time is reached, main power supply can be switched off!

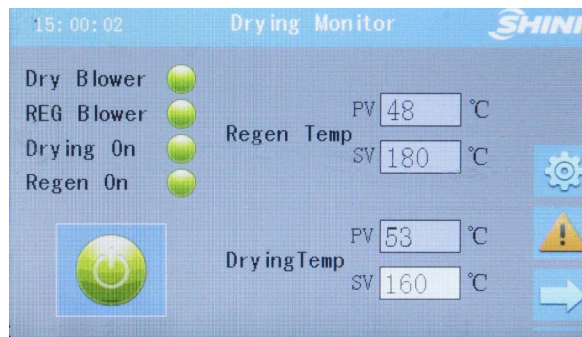

Fig. 4-5: Start-up and Shutdown Screen

4.1.3 User Menu Screen

Enter Menu Screen by pressing the <Button of function> on Drying Monitoring Screen or Conveying Monitoring Screen, which has two functional options: time setting, and multi-language setting.

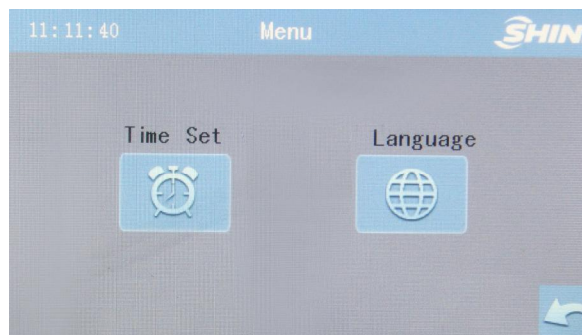

Fig. 4-6: User Meun Screen

4.1.3.1 Timer Setting

Enter into the Timer Screen by pressing the <Time Set> once on Menu screen. There are two options in this page, Time Set and WSET.

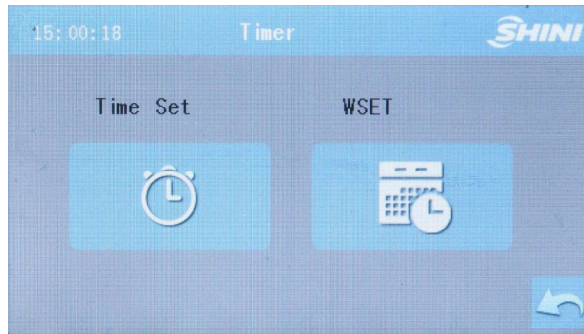

Fig. 4-7: User Menu Time Setting Screen

4.1.3.1.1 System Time Setting

Enter timer screen by pressing <Time Set> on this screen, which can set current date and system time.

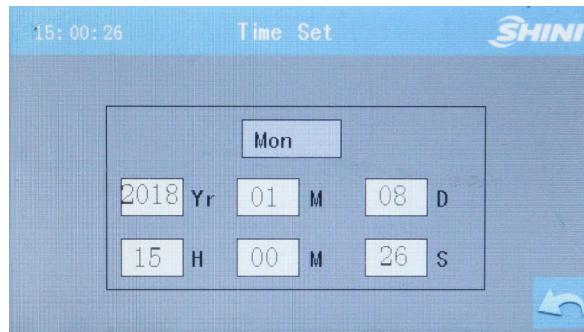

Fig. 4-8: System Time Setting

4.1.3.1.2 Weekly Timer Setting

Enter into this page by pressing <WSET> once on Timer Screen. It is possible to set the starting and stopping time for each day in one week, and press <OFF> to activate weekly timing function after setting.



Fig. 4-9: WSET Screen

Note: As to ensure normal working for weekly timing function, it is necessary to set the current time and date of system correctly before activating the weekly timing function.

4.1.3.2 Multilingual Setting

Chinese, English or Turkish can be switched at any time.

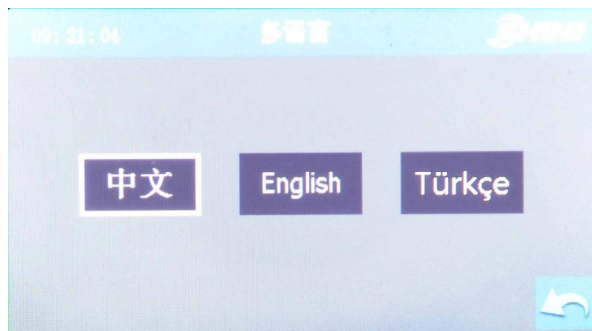

Fig. 4-10: Multilingual Setting Screen

4.1.4 Alarm Message Checking

Enter into this page by pressing <Button of Error Searching> once on Drying Monitoring Screen or Conveying Monitoring Screen. It's possible to check alarm history, reset alarm or mute alarm.



Fig. 4-11: Alarm Message Screen



Fig. 4-12: Alarm History Screen

4.1.5 Project Setting

Quickly and continuously click the top-left corner three times on Drying Monitoring Screen, and a password input window will pop up. Input the correct password (Default password: 3588) to enter project password setting page, which consists three options: Nor. Setting, Out Time and Password Setting.

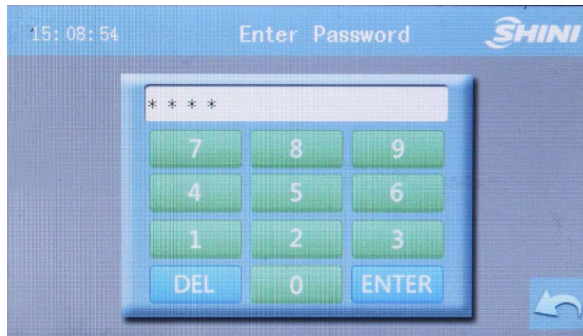

Fig. 4-13: Project Password Setting Screen

Note: Please keep this password securely and safely. If the password is missing, then the operator won't be able to log into this page. It is better to let this password known only by system administrator or senior operator!

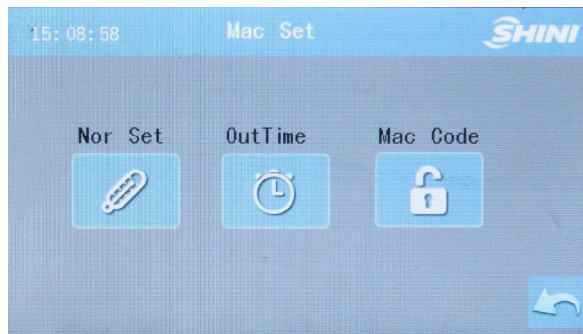
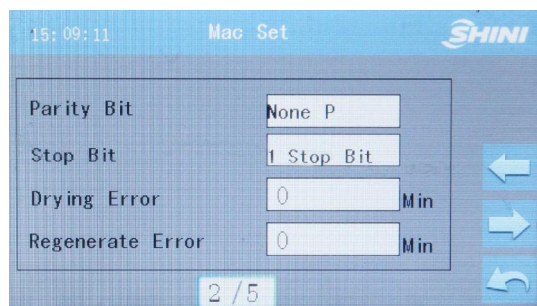
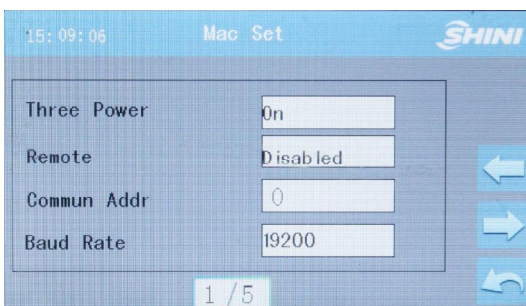

Fig. 4-14: Project Setting Screen



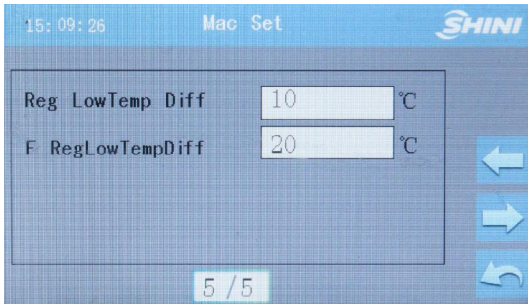
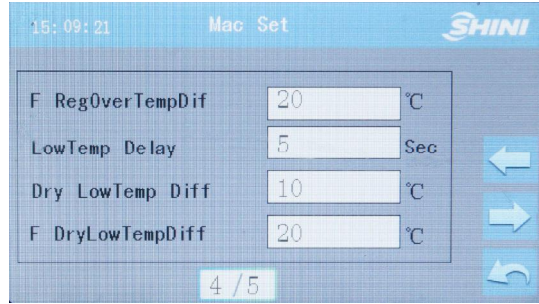
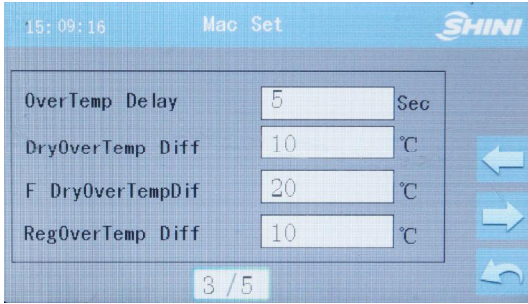

Fig. 4-15: Project General Setting Screen

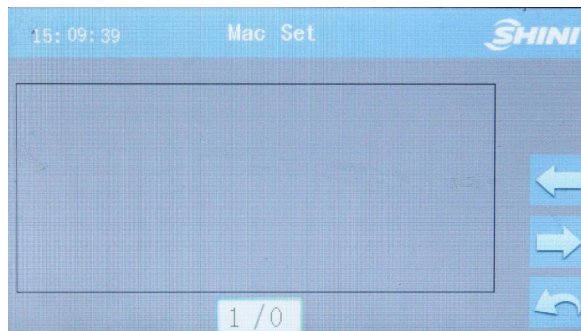

Fig. 4-16: Project Detection Time Setting Screen

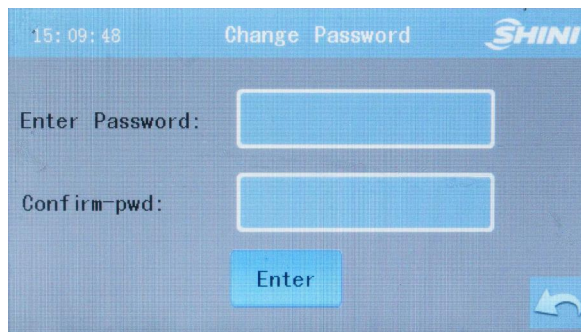

Fig. 4-17: Password Modification Setting Screen

Table 4-1: Project Setting Parameters

Catalog	Parameter	Setting Range	Remark
Nor. Set (Normal parameters setting)	Three-phase detection	se (use~forbidden)	Open or close the onboard three-phase detection
	External startup	Forbidden (use~forbidden)	Use: The dehumidification and drying system works when external start switch input is effective. Forbidden: external startup is forbidden. [J3-10 input definition] Visible only when the definition is "external startup and shutdown"
	Communication address	0 (0~32)	Address of communication devices
	Baud rate	19200 (4800/9600/19200)	Communication Baud rate
	Parity Bit	No parity (no parity, odd parity and even parity)	Setting of parity bit
	Stop bit	One stop bit (one stop bit, two stop bits)	Setting of stop bit
	Monitoring of drying heating error	0m (0~999min)	Drying heating disconnection
	Monitoring of regenerative heating error	0m (0~999min)	Regenerative heating disconnection
	Delayed overheat alarm	5s (0~999s)	Delayed time of overheat alarm
	Drying overheat deviation	10.0°C (0.0~40.0°C)	Drying overheat deviation
	First drying overheat deviation	20.0°C (0.0~60.0°C)	First drying overheat deviation
	Regenerative overheat deviation	10.0°C (0.0~40.0°C)	Regenerative overheat deviation
	First regenerative overheat deviation	20.0°C (0.0~60.0°C)	First regenerative overheat deviation
	Delayed low temp. alarm	5 secs. (0~999 secs.)	Delayed low temp alarm
	Drying low temp. deviation	10.0°C (0.0~40.0°C)	Drying low temp. deviation
	First drying low temp. deviation	20.0°C (0.0~60.0°C)	First drying low temp. deviation
	Regenerative low temp. deviation	10.0°C (0.0~40.0°C)	Regenerative low temp. deviation
	First regenerative low temp. deviation	20.0°C (0.0~60.0°C)	First regenerative low temp. deviation

5. Trouble-shooting

Symptom	Possible causes	Solution
EPROM Error	<ol style="list-style-type: none"> The machine halts when alarm rings, and it is manually reset after faults are removed. The ROM will be detected after being electrified, and error occurs when ROM can't read right datum. 	Re-power on. If the alarm rings again, there is something wrong with the controller. Please replace the controller or contact us.
Three-phase power source error	<ol style="list-style-type: none"> The machine halts when alarm rings, and it is manually reset after faults are removed. The part will be detected after being electrified, and error occurs when power line has reversed-phase connection or suffers default phase. The machine will be detected after being electrified. If the [J3-10 input definition] is three-phase electrical detection, alarm rings 2 secs. after effective J3-2 input. <p>Alarm will ring when either 2 or 3 is met.</p>	<ol style="list-style-type: none"> Turn off the power switch, change the three-phase AC power cord connection and set a positive phase. After re-powering on, observe whether the fault prompt has disappeared or not. If the [J3-10 input definition] is three-phase electric power detection, check whether the setting of "always on" and "always off" of the [external/three-phase power] is correct or not.
Regenerative Blower Overload	<ol style="list-style-type: none"> When alarm rings, drying blower/regenerative blower (rotor motor) close and heating stops. And they are automatically reset after faults are removed. The blower will be detected after being electrified, and error occurs when the regenerative blower overload input signal proves to be effective and delays for 2 secs. 	<p>Open the electronic control box and press the reset button on the thermorelay.</p> <p>Check the machine if problem arises again.</p>
Drying Blower Overload	<ol style="list-style-type: none"> When alarm rings, drying blower/regenerative blower (rotor motor) close and heating stops. And they are automatically reset after faults are removed. The blower will be detected after being electrified, and error occurs when the drying blower overload input signal proves to be effective and delays for 2 secs. 	<p>Open the electronic control box and press the reset button on the thermorelay.</p> <p>Check the machine if problem arises again.</p>
Regenerative EGO Overheat	<ol style="list-style-type: none"> Regenerative heating and overheat alarm output close when alarm rings, and they are automatically reset after faults are removed. The part will be detected after being electrified, and error occurs when the regenerative EGO overheat input signal proves to be effective and delays for 2 secs. 	<p>Check whether the setting of [regenerative EGO overheat] and that of "normally open" and "normally close" of overheat signal are correct or not.</p> <p>Examine the regenerative blower, filter, air pipes and air damper.</p>

Drying EGO Overheat	<p>1. Drying heating and overheat alarm output close when alarm rings, and they are automatically reset after faults are removed.</p> <p>2. The part will be detected after being electrified, and error occurs when the drying EGO overheat input signal proves to be effective and delays for 2 secs.</p>	<p>Check whether the setting of [regenerative EGO overheat] and that of “normally open” and “normally close” of overheat signal are correct or not.</p> <p>Examine the drying blower, filter, air pipes and air damper.</p>
Return Air EGO Overheat	<p>1. Drying heating closes when alarm rings, and it is automatically reset after faults are removed.</p> <p>2. The part is detected after being electrified, and error occurs when the return air EGO overheat input signal proves to be effective and delays for 2 secs.</p>	<p>Check whether the setting of [regenerative EGO overheat] and that of “normally open” and “normally close” of overheat signal are correct or not.</p> <p>Examine the drying blower, regenerative blower, filter, air pipes and air damper.</p> <p>After addressing the problem, press the key of “reset” or reset by re-powering on.</p>
Rotor Error	<p>1. The rotor automatically gets into the state of “timed cooling” when alarm rings, and it is manually reset after faults are removed.</p> <p>2. Error occurs when the rotor can’t be detected in the [rotor monitoring time] and the valid time of its input signal exceeds 10 secs.</p>	<p>Set the parameters according to the rotor conditions: time for the rotor to run a cycle [rotor monitoring time], and set aside a certain volume.</p> <p>If you want to disable this alarm, you can set the parameter [rotor monitoring time] as 0.</p> <p>After addressing the problem, press the key of “reset” or reset by re-powering on.</p>
Regenerative Heating Pipe Disconnection	<p>1. Regenerative heating closes when alarm rings, and it is manually reset after faults are removed.</p> <p>2. The error occurs when the regenerative heater is turned on and its temp can not reach the set temp during the period of [regenerative heating error monitoring].</p>	<p>Examine the regenerative heating pipe and its control circuit as well as heating contactor;</p> <p>If you do not use the alarm function, you can set the detection time of disconnection [regenerative heating error monitoring] as 0.</p> <p>After addressing the problem, press the key of “reset” or reset by re-powering on.</p>
Drying Heating Pipe Disconnection	<p>1. Drying heating closes when alarm rings, and it is manually reset after faults are removed.</p> <p>2. The error occurs when the drying heater is turned on and its temp can not reach the set temp during the period of [drying heating error monitoring].</p>	<p>Examine the drying heating pipe and its control circuit as well as heating contactor;</p> <p>If you do not use the alarm function, you can set the detection time of disconnection [drying heating error monitoring] as 0.</p> <p>After addressing the problem, press the key of “reset” or reset by re-powering on.</p>
Regenerative Probe Error	<p>1. Regenerative heating closes when alarm rings, and it is automatically reset after faults are removed.</p> <p>2. The part is detected after being electrified, and error occurs when there is something wrong with the probe.</p>	<p>Examine the wire and check whether the probe matches with the controller.</p>

Drying Probe Error	<p>1. Drying heating closes when alarm rings, and it is automatically reset after faults are removed.</p> <p>2. The part is detected after being electrified, and error occurs when there is something wrong with the probe.</p>	Examine the wire and check whether the probe matches with the controller.
Return Air Probe Error	<p>1. Drying heating closes when alarm rings, and it is automatically reset after faults are removed.</p> <p>2. The part is detected after being electrified, and error occurs when there is something wrong with the probe.</p>	<p>Examine the wire and check whether the probe matches with the controller.</p> <p>Examine the machine and press the key of "reset" after faults are removed.</p>
Regenerative Temp. Overheat	<p>1. When alarm rings, regenerative heating and overheat alarm output close. They are automatically reset when the regenerative temp < (regenerative set temp+ [regenerative overheat deviation]-1℃).</p> <p>2. Detection when the machine is running:</p> <p>A. Error occurs when regenerative temp– regenerative set temp > [regenerative overheat deviation] and [overheat alarm] is delayed.</p> <p>B. If the temp difference exceeds the [regenerative ceiling deviation] in modification of the set temp or when the unit just starts running, the alarm would not be given. The alarm rings only when the conditions listed in (1) are met even after the current temp goes up and down for several times at the set temp point.</p>	<p>Check whether the setting of parameter [regenerative ceiling deviation] is reasonable.</p> <p>If you want to disable it, set the [regenerative ceiling deviation] as 0.</p>
First Regenerative Overheat	<p>1. When alarm rings, regenerative heating and overheat alarm output close. They are automatically reset when the regenerative temp < (regenerative set temp+ [regenerative overheat deviation]-1℃).</p> <p>2. Inspect when the machine is running:</p> <p>(1) Error occurs when regenerative temp– regenerative set temp > [first regenerative overheat deviation] and [overheat alarm] is delayed.</p>	<p>Check whether the setting of parameter [first regenerative overheat deviation] is reasonable.</p> <p>If you want to disable it, set the [first regenerative overheat deviation] as 0.</p>
Too-low Regenerative	1. When alarm rings, the machine keeps	Check whether the setting of parameter

Temp	<p>running. It is automatically reset when the regenerative temp > (regenerative set temp- [regenerative low temp deviation]+1°C).</p> <p>2. Inspect when the machine is running:</p> <p>A. Error occurs when regenerative set temp- regenerative temp > [regenerative low temp deviation] and [low temp alarm] is delayed.</p> <p>B. If the temp difference exceeds the [regenerative low temp difference] in modification of the set temp or when the unit just starts running, the alarm would not be given. The alarm rings only when the conditions listed in (1) are met even after the current temp goes up and down for several times at the set temp point.</p>	<p>[regenerative low temp deviation] is reasonable.</p> <p>If you want to disable it, set the [regenerative low temp deviation] as 0.</p>
First Too-low Regenerative Temp	<p>1. When alarm rings, the machine keeps running. It is automatically reset when the regenerative temp > (regenerative set temp- [first regenerative low temp deviation]+1°C).</p> <p>2. Inspect when the machine is running:</p> <p>(1) Error occurs when regenerative set temp- regenerative temp > [first regenerative low temp deviation] and [low temp alarm] is delayed.</p>	<p>Check whether the setting of parameter [first regenerative low temp deviation] is reasonable.</p> <p>If you want to disable it, set the [first regenerative low temp deviation] as 0.</p>
Drying Temp. Overheat	<p>1. When alarm rings, drying heating and overheat alarm output close. They are automatically reset when the drying temp < (drying set temp+ [drying overheat deviation]-1°C).</p> <p>2. Detection when the machine is running:</p> <p>A. Error occurs when drying temp- drying set temp > [drying overheat deviation] and [overheat alarm] is delayed.</p> <p>B. If the temp difference exceeds the [drying overheat difference] in modification of the set temp or when the unit just starts running, the alarm would not be given. The alarm rings only when the conditions listed in (1) are met even after the current temp goes up and down for several times at the set temp point.</p>	<p>Check whether the setting of parameter [drying overheat deviation] is reasonable.</p> <p>If you want to disable it, set the [drying overheat deviation] as 0.</p>
First Drying Temp. Overheat	<p>1. When alarm rings, drying heating and overheat alarm output close. They are</p>	<p>Check whether the setting of parameter [first drying overheat deviation] is reasonable.</p>

	<p>automatically reset when the drying temp < (drying set temp+ [first drying overheat deviation]-1°C).</p> <p>2. Inspect when the machine is running:</p> <p>(1) Error occurs when drying temp– drying set temp > [first drying overheat deviation] and [overheat alarm] is delayed.</p>	<p>If you want to disable it, set the [first drying overheat deviation] as 0.</p>
<p>Too-low Drying Temp.</p>	<p>1. When alarm rings, the machine keeps running. It is automatically reset when the drying temp > (drying set temp- [drying low temp deviation]+1°C).</p> <p>2. Inspect when the machine is running:</p> <p>A. Error occurs when drying set temp– drying temp > [drying overheat deviation] and [low temp alarm] is delayed.</p> <p>B. If the temp difference exceeds the [drying low temp difference] in modification of the set temp or when the unit just starts running, the alarm would not be given. The alarm rings only when the conditions listed in (1) are met even after the current temp goes up and down for several times at the set temp point.</p>	<p>Check whether the setting of parameter [drying low temp deviation] is reasonable.</p> <p>If you want to disable it, set the [drying low temp deviation] as 0.</p>
<p>First Too-low Drying Temp</p>	<p>1. When alarm rings, drying heating and overheat alarm output close. They are automatically reset when the drying temp > (drying set temp- [first drying low temp deviation]+1°C).</p> <p>2. Inspect when the machine is running:</p> <p>(1) Error occurs when drying temp– drying set temp > [first drying low temp deviation] and [low temp alarm] is delayed.</p>	<p>Check whether the setting of parameter [first drying low temp deviation] is reasonable.</p> <p>If you want to disable it, set the [first drying low temp deviation] as 0.</p>
<p>Dew- point Meter Error</p>	<p>There is something wrong with the dew point transducer, and the machine keeps running after error occurs</p>	<p>Check whether the connection of dew point transducer is right, and whether the range is from 4 to 20 mA.</p>
<p>Rotor 2 Error</p>	<p>1. The rotor automatically gets into the state of “timed cooling” when alarm rings, and it is manually reset after faults are removed.</p> <p>2. Running detection: error occurs when the rotor can't be detected in the [rotor monitoring time] and the valid time of its input signal</p>	<p>Set the parameters according to the rotor conditions: time for the rotor to run a cycle [rotor monitoring time], and set aside a certain volume.</p> <p>If you want to disable this alarm, you can set the parameter [rotor monitoring time] as 0 or define the [J3-10 input] to be forbidden.</p>

	exceeds 10 seconds.	After addressing the problem, press the key of "reset" or reset by re-powering on.
Too-high Dewpoint Temperature	<p>1. When alarm rings, the machine keeps running. It is automatically reset when dewpoint temp. < [dew point alarm temp.].</p> <p>2. Inspect when the machine is running:</p> <p>A) Press [dewpoint temp alarm delay] and start detecting;</p> <p>B) Dewpoint temp> [dew point alarm temp] and the condition lasts for 10 seconds.</p> <p>C) The parameter of [delayed detection of dewpoint alarm] is not 0.</p> <p>Alarm will be given when A), B) and C) are all met.</p>	If you want to disable it, set the parameter [delayed detection of dewpoint alarm] as 0

6. Maintenance and Repair

Check the accuracy of the temperature controller.
Period: Daily.

Check whether the dew point is normal. (when dew-point monitor is installed on the machine) Period: Daily.

Check whether the contactor is normal.
Period: Weekly.

Replace the PC board.
Period: every 3 years.

Replace the no fuse switch. Period: when damage occurs.

Check whether the air pipeline.
Period: Weekly.

The maintenance and repair of honeycomb
a. make sure the gear motor and the synchromesh gear have no damage.
b. clean the honeycomb.
Period: Semiyearly.

Replace the heaters when breaking down.

Check the over temperature protector (stop heating when heater temperature reaches the set value of over temperature protector.)

Clean the cooler.
Period: Semiyearly.

Clean the dust-proof screen. Period: Monthly

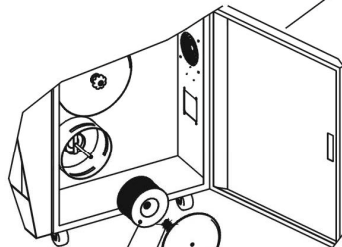

Filter
Butterfly nut
Filtering barrel lid
Star nut

Filter cleaning
Period: Daily.

Cleaning steps: unscrew the plum flower nut, demount the filter cover, unscrew the butterfly nut and take out the filter. Use compressed air to blow off the dust from inside out. Reinstall it after cleaning.

Notice: do not fall any impurities into the filter.

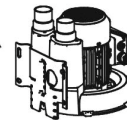

Clean the Blower

- a. Blow off the dust inside and outside the blower. Period: Monthly.
- b. Replace the bearing, grease seal and muffler according to the operating environment.
- c. Replace the blades, shell and metal mesh according to the operating environment.

6.1 The Useful Life of the Key Parts of the Product

Table 6-1: The useful life of the key parts of the product

Name of the Parts	Useful Life
Blower	Above 5 years
Process heater	Above 1 year
Regen. heater	Above 1 year
Contactora	Above 2000,000 act
Honeycomb	5 years
Filter	1 year

6.2 Filter

Please periodically clean the dust on the air filters, once per week.

Cleaning steps:

- 1) Take out the air filter carefully.
- 2) Blow off the dust on the air filter screen and the cover with pressure air.
- 3) Wipe off the barrel wall of air filter with dishcloth.
- 4) After cleaning, place all parts in reversed order carefully.
- 5) Please ensure that the filter is well seal with metal frame.



Picture 6-1: Filter



Note!

Don't let foreign object enter into the barrel, when taking out the air filter.

6.3 Honeycomb-rotor

6.3.1 What is Honeycomb-rotor

The main body of the honeycomb-rotor is a honeycomb, made by ceramic fibre and organic additives, sintered under high temperature with molecular sieve and silica gel, to be strongly bonded together and form a solid and hard surface. Not like common molecular sieve, which will produce dusts and fines to pollute raw materials when aging or become saturated requiring regular replacement, the moisture of return air is quickly absorbed by numerous tunnels before coming out of the rotor to form low dew-point air. At the same time, regenerating blower takes dry air into the honeycomb-rotor from an opposite direction to regenerate the rotor.



Picture 6-2: Honeycomb Rotor

6.3.2 Installation of the Rotor

- 1) The upper and lower lid of honey-comb should install Teflon gasket (Fig. 1).
- 2) Use 4 screws to fix the rotor base on the machine frame firmly, and then install the shaft accordingly (Fig. 2).
- 3) Install the gearmotor and transmission gear (Fig. 4).
- 4) Install and fix the main support screws (Fig. 3).
- 5) Fit the transmission belt in proper position (Fig. 6).
- 6) Install the honeycomb-rotor (Fig. 9) and transmission belt (Fig. 12).
- 7) Fix the rotor top cover (Fig. 8).
- 8) Fit all springs and tighten the screws (Fig. 7).
- 9) Install both the transmission belt (Fig. 13) and belt tension regulator (Fig. 14).
- 10) Install micro-switch and fixed board firmly (Fig. 10).



Picture 6-3: Installation of The Rotor

6.3.3 Honeycomb Rotor Cleaning Steps

- 1) Use a vacuum-cleaner with brush to suck up the dust on rotor surface.
- 2) Blow off the dust in the rotor channels with compressed air.
- 3) If there is dirt sticking to the channel walls inside the rotor, cleaning steps are as follows:
 - a. Saturate the rotor by blowing humid air (higher than 60%RH) through the rotor without having regeneration circuit on. This can be done by just turning the regeneration heater off and still have the process blower running if process air has high humidity. If the process air is too dry try to put a humidifier in the air stream. Do this for one hour.
 - b. According to the character of the dirt, sink the rotor into water with cleaning agent in it (PH value 3~2 liquid is applied to silica gel, PH value 7~10 applied to molecular valve). Greasy dirt should be put into a detergent solution with xylene. 15 minutes cleaning is suggested.
 - c. Take the rotor out of the liquid and let it rest with the channels vertically for 5

minutes so the liquid can run out.

- d. Blow off the residual liquid in the channels with compressed air.
- e. Put the rotor back into the dehumidifier and run the unit with regeneration circuit (the regeneration temperature between 50°C and 60°C) on for at least one hour.



Note!

1. Note that in the dry air and wet air outlets, there will be high concentrations liquid out for some time. If a solvent has been used, there will be a residual smell for several days.
2. For some dirt which is greasy and sticky in the rotor, 100% elimination is impossible. The only one thing you can do is to replace the rotor for the cleaned rotor performance can only be recovered partly.

6.4 EGO



The EGO value has been setting before out factory, Don't modify it.



	Default Value
Drying	200°C
Regenerating	200°C

Picture 6-4: EGO

6.5 Cooler Clear Step

- 1) Disassemble the cooler's pipe and screw, and remove the cooler out of the chiller.
- 2) Release the fixed screw on the upper and lower cover of cooler and disassemble the cover.
- 3) Use brushes, compressed air or low pressure water to clean the dust and sundries on the cooler fan and copper pipe. Notes: water residue on the cooler fan and copper pipe should be dried with compressed air.
- 4) Make the cooler's upper and lower cover junction clean enough and smear the silica gel then fixed the covers with screws.

- 5) Put the cooler on the air at least 4 hours to make the silica gel drying enough then fix the cooler on the chiller and connect all pipes.

6.6 Dewpoint Monitor (Option)

6.6.1 Installation for Dewpoint Monitor

- 1) Cut off the film on control panel. Slightly cut it with the blade as there reserved with the holes.



Picture 6-5: Hole Site

- 2) Check if there are complete parts for dewpoint monitor including:
 - Dew-point monitor
 - Dew-point transmitter assembly (dew-point detector, detection cable, washer and installation guide)
 - Copper joint, installation seat for dew-point monitor



Picture 6-6: Parts of Dew-point Monitor

- 3) Remove the dew-point detector assembly from the machine, and mount it to another $\Phi 28$ hole on the controller. Install a dew-point monitor base on

original hole, and mount two Teflon pipe connectors on the base. Via the copper pipe, one connector connects to the honeycomb and another connects to the dew-point detector assembly.



Picture 6-7: Copper Joint Assembly of Original Machine

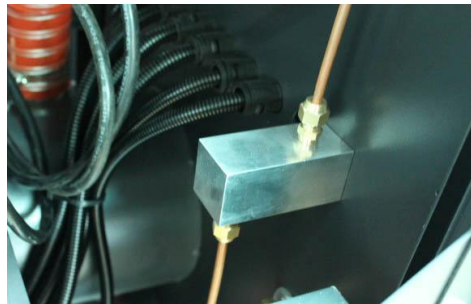

Picture 6-8: Installation Seat

4) Install dew-point transmitter assembly to copper joint.

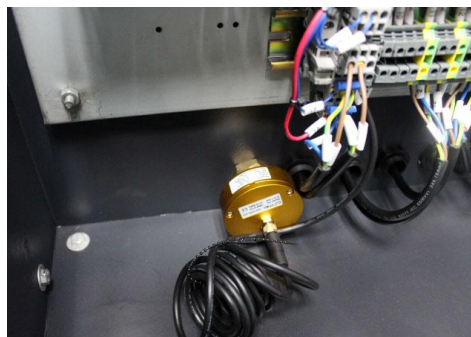

Picture 6-9: Installation for Transmitter

5) Insert the dew-point monitor into the hole on the panel and fasten it.

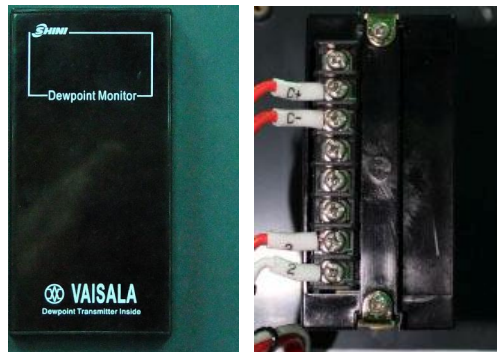

Picture 6-10: Connection of Signal Wire

6) Connect signal wires of the transmitter and power lines of dew-point monitor with the according terminals.

Connect contact No.1 and No.2 with power, supply is 220VAC.

Contact No.3, No.4 and No.5 are idle.

Connect contact No.6 and No.7 with the signal of transmitter. (C- Connects contact No.6, C+ connects contact No.7)

Dew-point transducer wiring (white connect to C-, blue connect to C+)

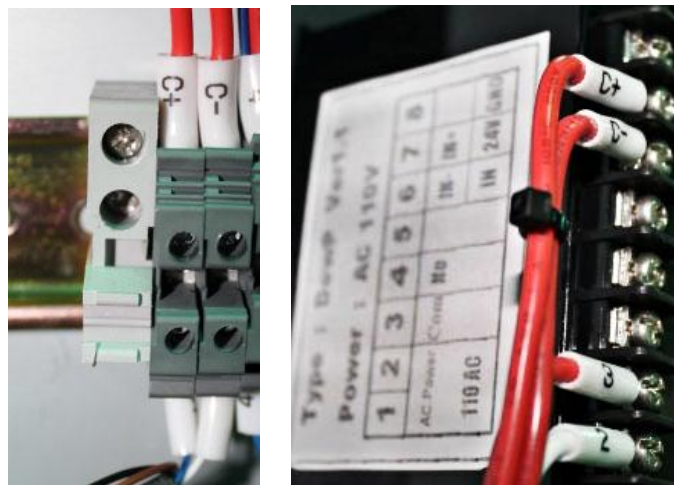

Picture 6-11: Connection of Dew-point Monitor

6.6.2 Dew-point Monitor Setting

1. Common mode functional setting (adjust dew-point alarm setting value):

- 1) Press "S" key to enter setting (after entering, the display flickers);
- 2) Adjust dew-point alarm setting value, and press "U" and "D" to adjust the value.
- 3) Press "E" and save setting value.
- 4) Press "S" to leave setting mode.

2. Special mode functional setting:

Enter this mode. Firstly hold "U" "D" for three secs. and enter (after enter special mode, it displays F-X in which X means that different number.);

Menu functions:

F-3: °C or °F in unit

F-5: it is +20°C when input 20 ampere

F-6: it's in min. temp. when signal input is 4 ampere. For example, if the measuring range of dew-point transmitter is -60~+20°C (this range always marks on the transmitter), therefore F-6 should be -60°C, F-5 should be +20°C.

F-7: the upper limit value (99-99)

F-8: the lower limit value (99-99)

6.7 Maintenance Schedule

6.7.1 General Machine Information

Model _____ SN _____ Manufacture date _____

Voltage _____ Φ _____ V Frequency _____ Hz Power _____ kW

6.7.2 Check after Installation

- Check that the conveying pipes are tightly locked.
- Check that the material clearance door is firmly closed.
- Check that the conveying pipes are correctly connected.
- Check if there are damages of honeycomb-rotor.

Electrical Installatio

- Voltage: _____ V _____ Hz
- Fuse melt current: 1 Phase _____ A 3 Phases _____ A
- Check the phase frequency of power supply.
- Check rotating direction of regenerating motor.
- Check rotating direction of conveying blower fans.

Check air supply of compressor

- Compressed air pressure _____ bar
- Air flow _____ L/nun
- Check if the compressed air purified or not.

6.7.3 Daily Checking

- Check the switch of the machine.
- Check auto start-up of the machine.
- Check the temperature controller.
- Clean the filter.
- Check whether overheat protection is normal.
- Check whether dew-point is normal.

6.7.4 Weekly Checking

- Check all the electrical wires.

- Check if there are loose electrical connections.
- Check and maintain compressed-air filter and regulator.
- Check solenoid valve.
- Check motor overload relay and anti-phase function.
- Check whether air pipe is shed, leaked and loose.

6.7.5 Monthly Checking

- Check if transmission belt is loose or not.
- Check the status of gear motor performance.
- Check if there is leakage in the rotor.

6.7.6 Half-yearly Checking

- Check if there are damages of conveying pipe.
- Check the pipe heater.
- Check regenerating/conveying blower and fans of the motor.
- Check whether honey-comb rotor belt is damaged.
- Clean the cooler.

6.7.7 Yearly Checking

- Check whether the contactor is normal ¹.

6.7.8 3 year Checking

- PC board renewal.
- No fuse breaker renewal.

Note: 1. Manufacturer laboratory data for AC contactor is two million times in life. we suggest service life for one million four hundred thousand times, if work eight hours per day, recommended replacing frequency is 1.5 years, if work day and night, replacement is suggested to be done every six months.