

版本 Ver.A

Mark	Before modification	After modification	Modified by	Modify date	Checked by	Date	20170310
Drawer					Version	0	
Designer					Approved by		
Proofread by							

Title
SG-2130EB
Main Circuit Diagram and
Control Circuit Diagram

Drawing NO
SG-2130EB-GB-230V-0-1

Scale	Page 1
Standard GB	Totally 3 Pages

SHINI 信易電熱機械股份有限公司
Shini Plastics Technologies, Inc.

Voltage	230V
Frequency	50Hz

1 2 3 4 5 6 7 8

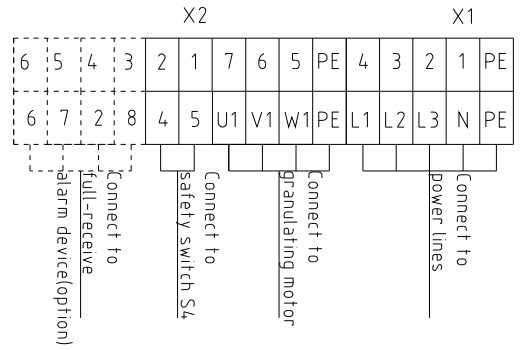
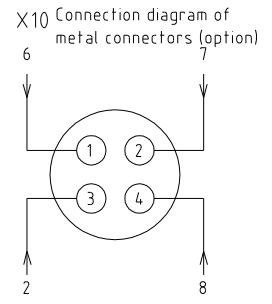
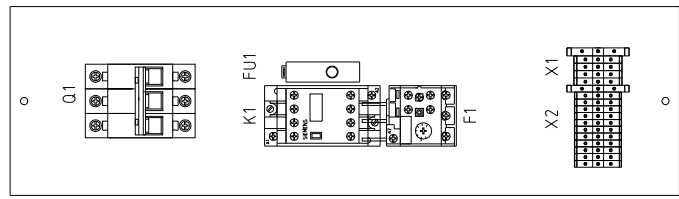
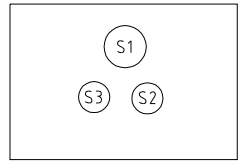

版本 Ver.A

Mark	Before modification	After modification	Modified by	Modify date	Checked by	Date	20170310
					Proofread by	Approved by	
					Designer	Version	0
					Drawer		

Title SG-2130EB
 Electrical Components Layout
 Drawing NO SG-2130EB-GB-230V-0-2

SHINI 信易電熱機械股份有限公司
 Shini Plastics Technologies, Inc.

Scale	Page 2
Standard GB	Totally 3 Pages
Voltage	230V
Frequency	50Hz

1 2 3 4 5 6 7 8

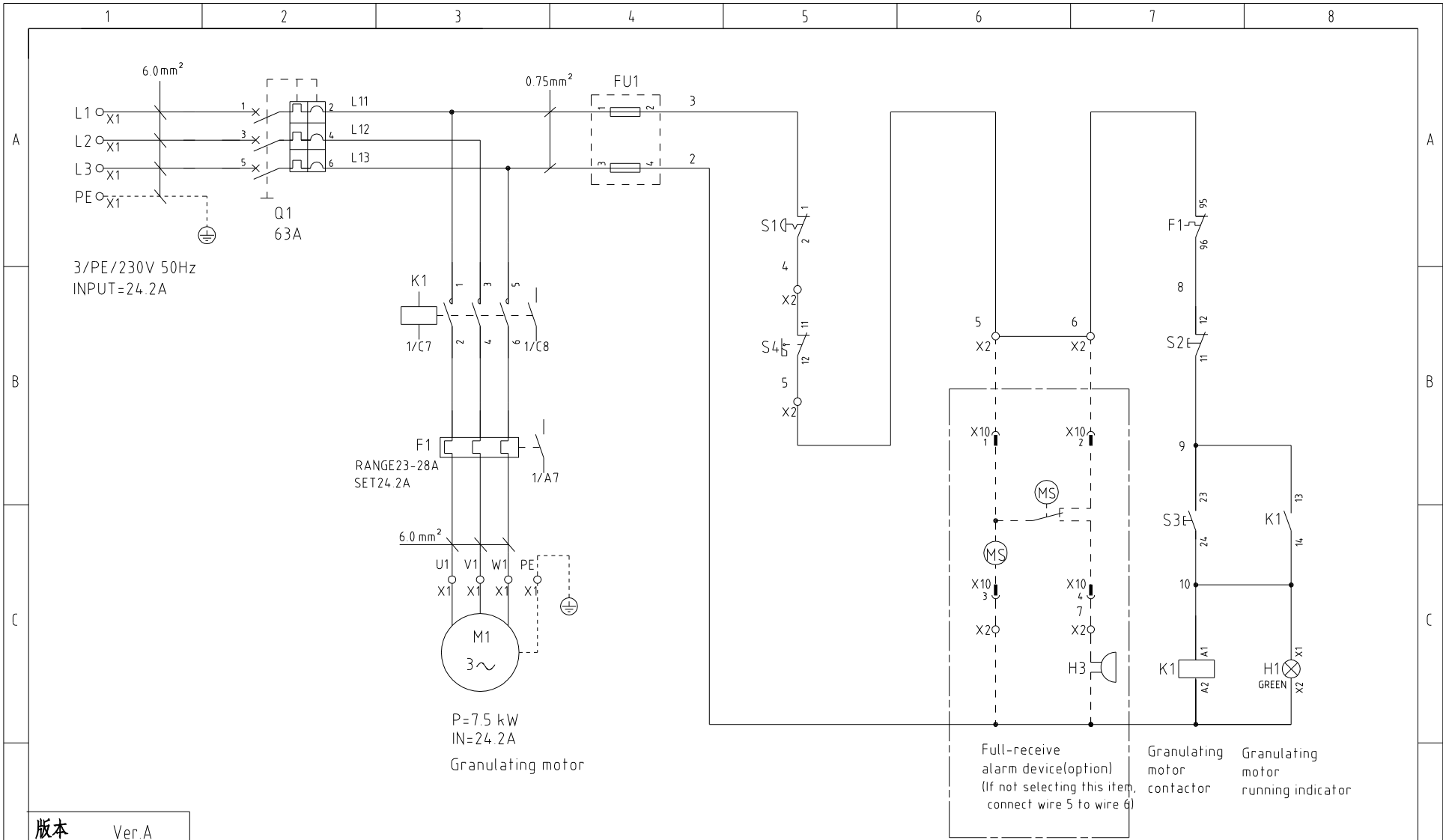

版本 Ver.A

Mark	Before modification	After modification	Modified by	Modify date	Checked by	Date	20150909

Title SG-2540EB Main Circuit Diagram and Control Circuit Diagram		Drawing NO SG-2540EB-GB-230V-0-1		Scale	Page 1
SHINI 信易電熱機械股份有限公司 Shini Plastics Technologies, Inc.		Standard	GB	Totally 3	Pages
		Voltage		230V	
		Frequency		50Hz	

1 2 3 4 5 6 7 8

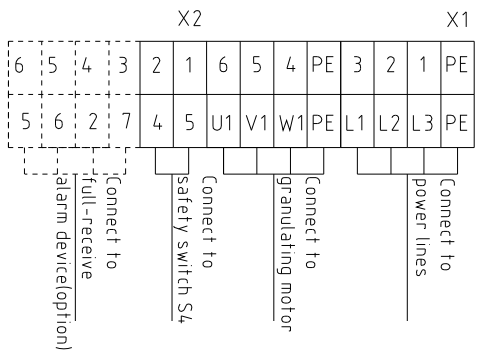
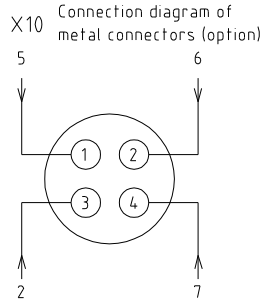
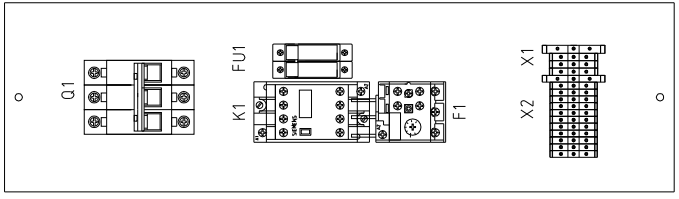
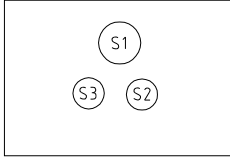

版本 Ver.A

Drawer	Version	0
Designer	Approved by	
Proofread by	Date	20150909
Checked by		
Mark	Before modification	After modification
	Modified by	Modify date

Title SG-2540EB
 Drawing NO SG-2540EB-GB-230V-0-2
 Electrical Components Layout



Scale	Page	2
Standard	GB	Totally 3 Pages
Voltage	230V	
Frequency	50Hz	

1 2 3 4 5 6 7 8

1		2		3		4		5		6		7		8							
NO	Symbol	Name		Manufacturer		Type		Specification		Number	Material number		Remark								
A	1	Q1	Circuit breaker		TECO		BM-63C/3063S		63A		1	YE40306303000									
	2	K1	Contactor		SIEMENS		3RT6028-1AN20		220V 50/60Hz		1	YE00602822000									
	3	F1	Overload relay		SIEMENS		3RU6126-4NB0		23-28A		1	YE01612620000									
	4	FU1	Fuse		CHNT		RT18-32		2P		1	YE41032200000									
	5		Fuse core		CHNT		10×38 500V 2A		2A		2	YE46002000100									
	6	X1	Terminal		PHOENIX		TB6 I		6.0mm ²		6	YE61060000000									
	7				PHOENIX		TB6 PE I		6.0mm ² PE		2	YE61063500000									
B	8	X2	Terminal		PHOENIX		TB2.5B I		2.5mm ²		2	YE61250040000									
	9				PHOENIX		TB2.5B I		2.5mm ²		4	YE61250040000		(2)							
	10	H3	Buzzer		TEND		EA-2		220VAC		1	YE84222000000		(1)(2)							
	11	S1	Emergency stop button		ABB		MPET4-10R+MCBH-00+MCB-01		1NC		1	YE11411000000		(1)							
	12	S2	Stop button		ABB		CP1-10B-01		1NC		1	YE11113100000		(1)							
	13	S3,H1	Start button		ABB		CP1-13G-10		1NO		1	YE11100100000		(1)							
	14	S4	Safety switch		SCHMERSRC		AZ15-02ZVRK-1476		AZ-15		1	YE16147600100		(1)							
C	15	MS	Material level sensor		SIPAI		SR-80		220VAC		1	YE15000200100		(1)(2)							
	16	X10	Metal tie in		APEX		PLT-254-PM		4P		1	YE68025400000		(1)(2)							
	17				APEX		PLT-254-RF		4P		1	YE68025400100		(1)(2)							
	18	M1	Granulating motor		-----		7.5kW		230V 50Hz		1	-----		(1)							
	19		Cable 6.0x5Cx5M						BA		1.00	BE51060500250		(1)							
D	版本 Ver.A		Notes: (1)Means it's not the material inside the control box.(2)Means optional accessories of full-receive alarm device																		
					Drawer		Version		0		Title		SG-2540EB		Drawing NO		Scale		Page 3		
					Designer		Approved by				Electrical Components List		SG-2540EB-GB-230V-0-3		Standard		GB		Totally 3 Pages		
	Mark		Before modification		After modification		Modified by		Modify date		Checked by		Date		20150909		 信易電熱機械股份有限公司 Shini Plastics Technologies, Inc.		Voltage		230V
																Frequency			50Hz		

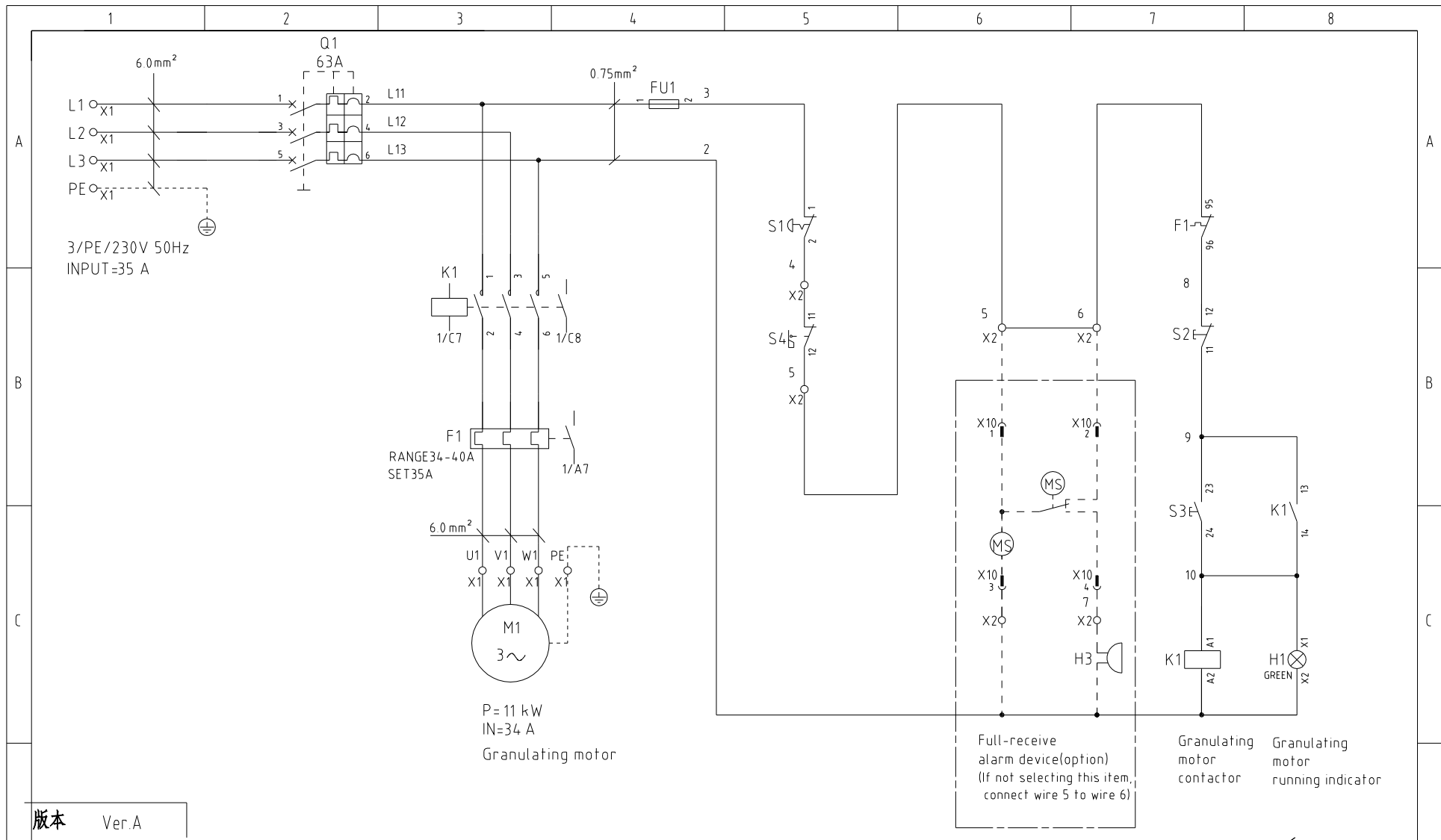

版本 Ver.A

				Drawer	Version	0	Title	SG-2950EB	Drawing NO	Scale	Page 1
				Designer	Approved by		Main Circuit Diagram and Control Circuit Diagram	SG-2950EB-GB-230V-0-1	Standard	GB	Totally 3 Pages
				Proofread by	Date	20170310	 信易電熱機械股份有限公司 Shini Plastics Technologies, Inc.		Voltage	230V	
Mark	Before modification	After modification	Modified by	Checked by		Frequency			50Hz		

1 2 3 4 5 6 7 8

1 2 3 4 5 6 7 8

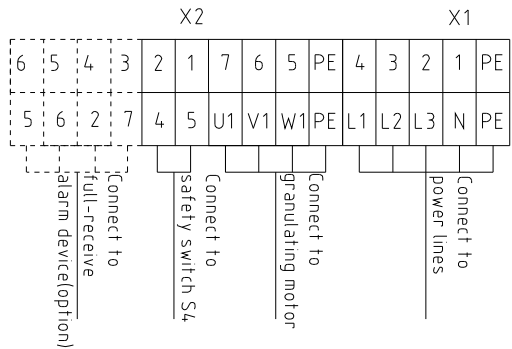
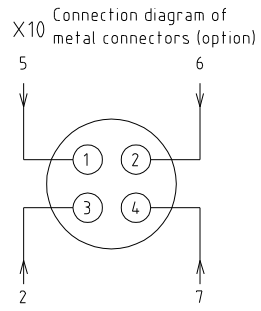
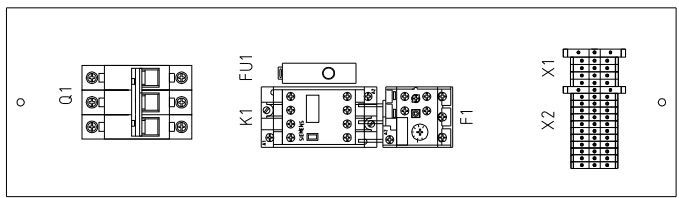
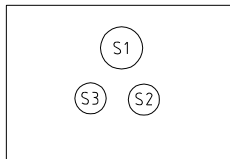

版本 Ver.A

Mark	Before modification	After modification	Modified by	Modify date	Checked by	Date	20170310
					Proofread by	Approved by	
					Designer	Version	0
					Drawer	Title	SG-2950EB

Electrical Components Layout SG-2950EB-GB-230V-0-2



Scale	Page	2
Standard	GB	Totally 3 Pages
Voltage	230V	
Frequency	50Hz	

1 2 3 4 5 6 7 8

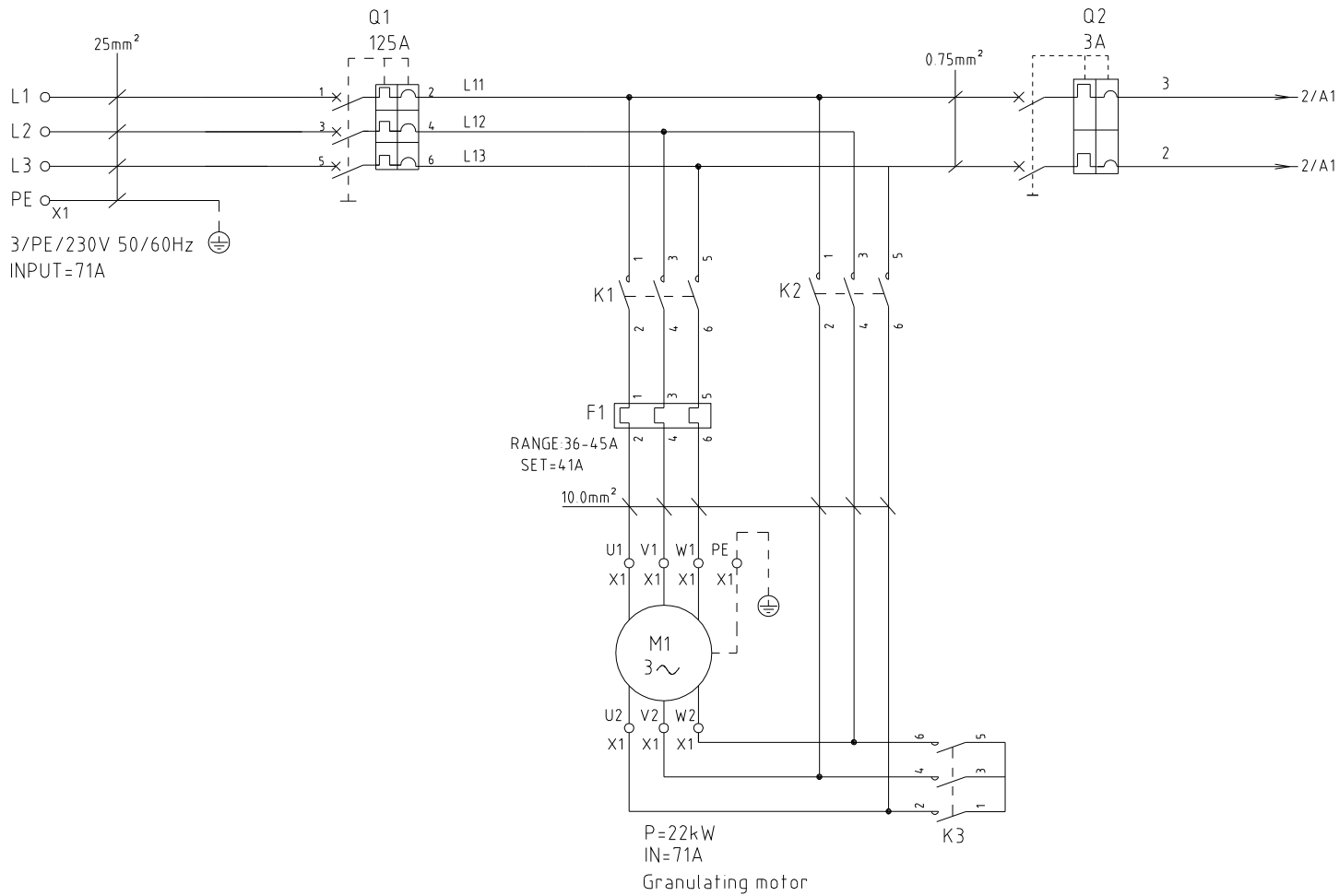

					制图		版号	0	标题	SG-4880EB	图号	比例	第 1 张
					设计		核 准		主电路图	SG-4880EB-GB-230V-0-1	标准	GB	共 4 张
					校对						机器电压	230V	
标记	更改前	更改后	更改人	日期	审核		日期	20190228	 信易電熱機械股份有限公司 Shini Plastics Technologies, Inc.		机器频率	50Hz	

1

2

3

4

5

6

7

8

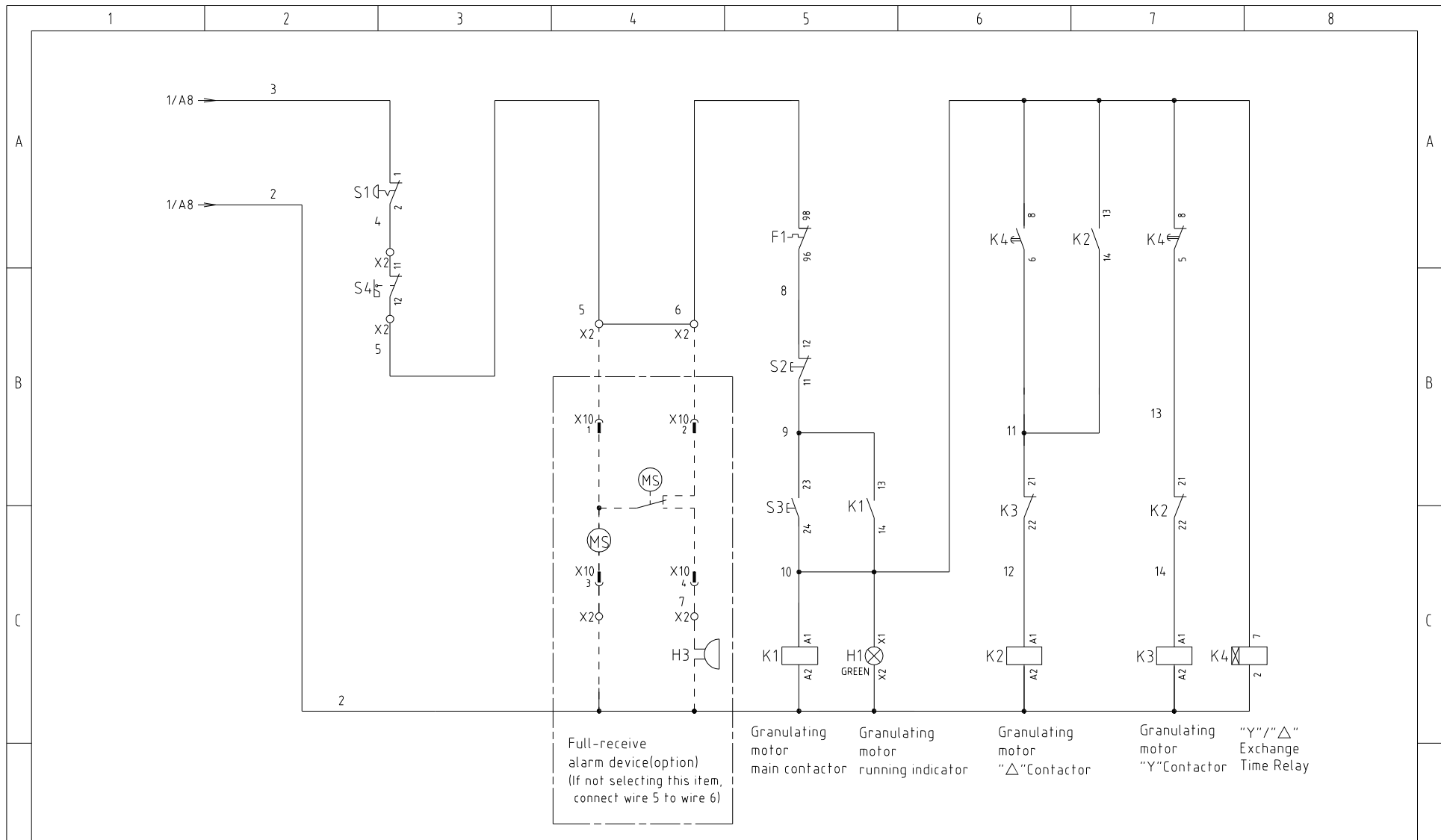

					制图	版号	0	标题	SG-4880EB	图号	比例	第 2 张
					设计	核		控制电路图	SG-4880EB-GB-230V-0-2	标准	GB	共 4 张
					校对	准		信易電熱機械股份有限公司 Shini Plastics Technologies, Inc.	机器电压	230V		
标记	更改前	更改后	更改人	日期	审核	日期	20190228		机器频率	50Hz		

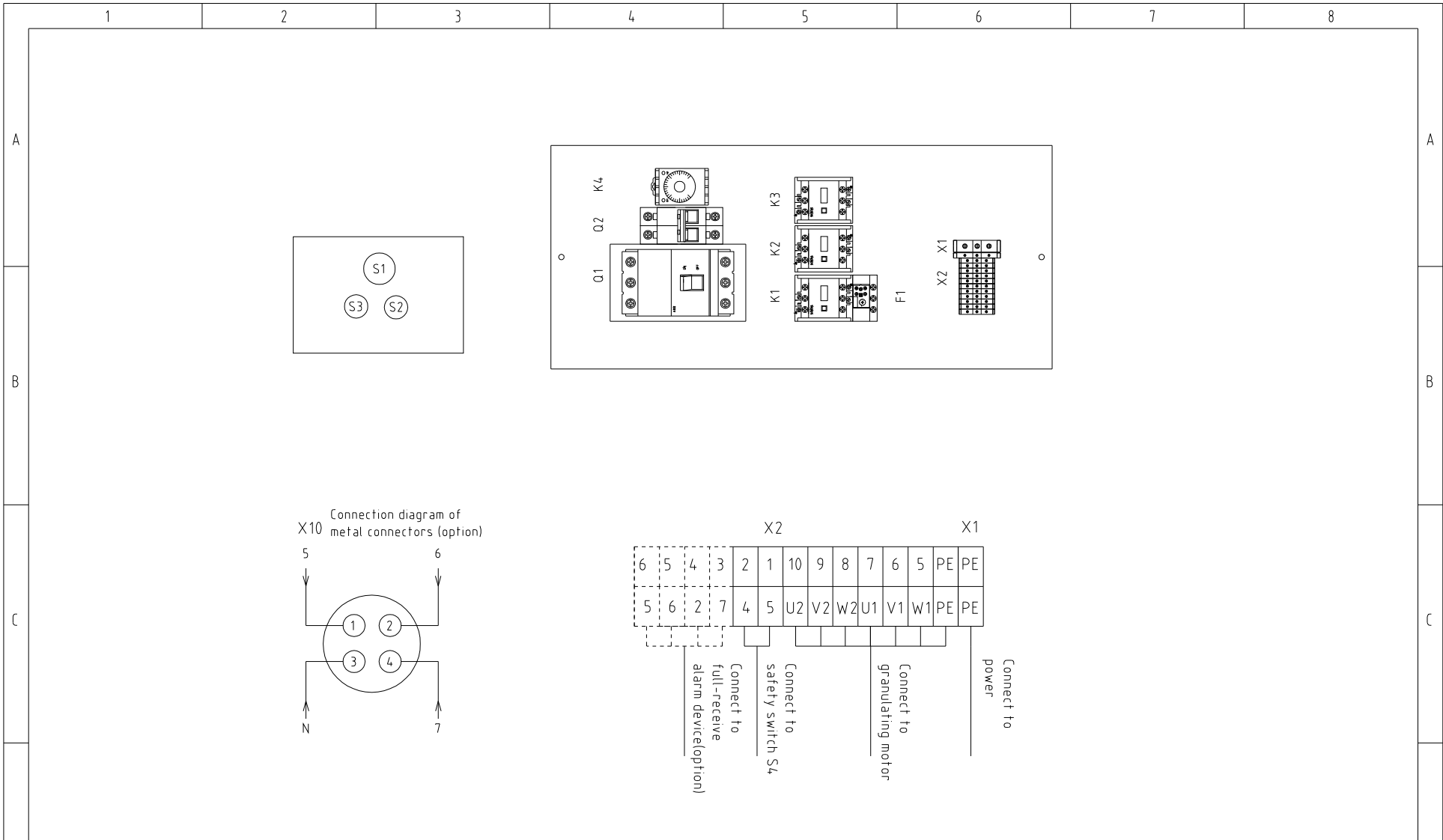

					制图	版号	0	标题	SG-4880EB	图号	比例	第 3 张
					设计	核	准	电气元件布置图	SG-4880EB-GB-230V-0-3	标准	GB	共 4 张
					校对	日期		SHINI 信易電熱機械股份有限公司 Shini Plastics Technologies, Inc.			机器电压	230V
标记	更改前	更改后	更改人	日期	审核	日期	20190228		机器频率	50Hz		

1		2		3		4		5		6		7		8	
序号/NO	符号/Symbol	名称/Name		制造商/Manufacturer		型号/Type		规格/Specification		数量/Number	物料编号/Material number		备注/Remark		
1	Q1	门连锁断路器/Break Interlock		ABB		A1A125TMF125/12503PFF		125A		1	YE41161400000				
2	Q2	断路器/circuit breaker		TECO		BM-63C/2003S 2P		3A		1	YE40200203000				
3	K1 K2	接触器/Contactor		SIEMENS		3RT5036-1AN20		50A 220V 50/60Hz		2	YE00503600000				
4	K3	接触器/Contactor		SIEMENS		3RT5035-1AN20		40A 220V 50/60Hz		1	YE00503500000				
5		辅助触点/Auxiliary Contactor		SIEMENS		3RH5921-1CA01		1NC		2	YE00592110100				
6		辅助触点/Auxiliary Contactor		SIEMENS		3RH5921-1CA10		1NO		2	YE00592110000				
7	F1	热过载继电器/Overload relay		SIEMENS		3RU5136-4GBO		36-45A		1	YE01612660000				
8	K4	时间继电器/Timer relay		YUYUN		TH3M-NAB		3S~60M 230VAC		1	YE86300300000				
9	X1	端子排/Terminal board		HONEYWELL		GK16PE		16mm ² PE		1	YE60001603500				
10				HONEYWELL		SK10		10mm ²		6	YE60001003200				
11				HONEYWELL		GK10PE		10mm ² PE		1	YE60001003500				
12	X2	端子排/Terminal board		HONEYWELL		SK2.5		2.5mm ²		2	YE60002503200				
13				HONEYWELL		SK2.5		2.5mm ²		4	YE60002503200		(2)		
14	H3	蜂鸣器/Buzzer		TEND		EA-2		220VAC		1	YE84222000000		(1)(2)		
15	S1	急停按钮开关/Emergency stop button		ABB		MPET4-10R+MCBH-00+MCB-01		1NC		1	YE11411000000		(1)		
16	S2	停止按钮开关/Stop button		ABB		CP1-10B-01		1NC		1	YE11113100000		(1)		
17	S3,H1	启动按钮开关/Start button		ABB		CP1-13G-10		1NO		1	YE11100100000		(1)		
18	S4	安全开关/Safety switch		SCHMERSRC		AZ15-02ZVRK-1476		AZ-15		1	YE16147600100		(1)		
19	MS	料位开关/Material level switch		SIPAI		SR-80		220VAC		1	YE15000200100		(1)(2)		
20	X10	金属接头/Metal connector		APEX		PLT-254-PM		4P		1	YE68025400000		(1)(2)		
21				APEX		PLT-254-RF		4P		1	YE68025400100		(1)(2)		
22	M1	粉碎电机/Granulating motor		-----		22kW		230V 50/60Hz		1	-----		(1)		
Note: (1) materials not included in the control box, (2)Means optional accessories of full-receive alarm device.															
				制图		版号		0		标题		图号		比例	
				设计		核				SG-4880EB		SG-4880EB-GB-230V-0-4		第 4 张	
				校对		准				电气元件明细表				共 4 张	
标记		更改前		更改后		更改人		日期		SHINI 信易電熱機械股份有限公司 Shini Plastics Technologies, Inc.		机器电压		230V	
												机器频率		50Hz	
1		2		3		4		5		6		7		8	