

## 1. Assembly Drawing

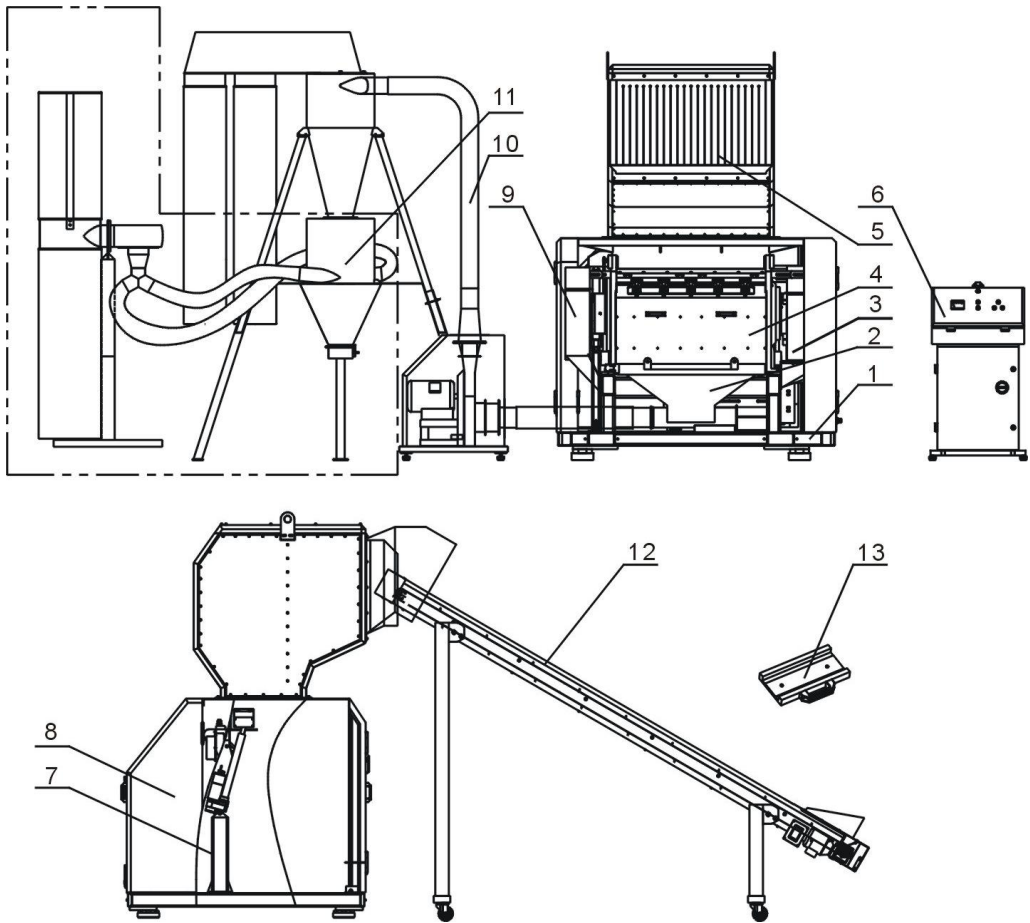

Note: Please refer to material list 2 about the parts code.

## 2. Parts List

No.	Name	SG-5080		SG-50110		
		Parts No.	Qua.	Parts No.	Qua.	
1	Rack assembly	-	1	-	1	
2	Storage box	-	1	-	1	
3	Main drive	-	1	-	1	
4	Cutting chamber assembly	3 rotating blades	BH85508000050	1	BH85501100050	1
		5 fixed blades	-	1	-	1
5	Feed box assembly	-	1	-	1	
6	Control box	-	1	-	1	
7	Electronic handspike assembly	-	1	-	1	
8	Soundproof box assembly	-	1	-	1	
9	Flywheel device	-	1	-	1	

10	Material conveyor assembly		-	1	-	1
11	Dust separator system		BY50360000050	1	BY50360000050	1
12	Belt conveyor		-	1	-	1
13	Presetting knife jig	3 rotating blades	BH1050800014	1	BH10501102310	1
		5 fixed blades	-	1	-	1
No.	Name		SG-5080B		SG-50110B	
			Parts No.	Qua.	Parts No.	Qua.
1	Rack assembly		-	1	-	1
2	Storage box		-	1	-	1
3	Main drive		-	1	-	1
4	Cutting chamber assembly	3 rotating blades	BH85508000050	1	BH85501100050	1
		5 fixed blades	-	1	-	1
5	Feed box assembly		-	1	-	1
6	Control box		-	1	-	1
7	Electronic handspike assembly		-	1	-	1
8	Soundproof box assembly (optional)		-	-	-	-
9	Flywheel device ( optional )		-	1	-	1
10	Material conveyor assembly (optional)		-	1	-	1
11	Dust separator system (optional)		BY50360000050	1	BY50360000050	1
12	Belt conveyor(optional)		-	1	-	1
13	Presetting knife jig (optional)	3 rotating blades	BH1050800014	1	BH10501102310	1
		5 fixed blades	-	1	-	1

Please confirm the version of manual before placing the purchase order to guarantee that the item number of the spare part is in accordance with the real object.

### 3. Cutting Chamber Assembly

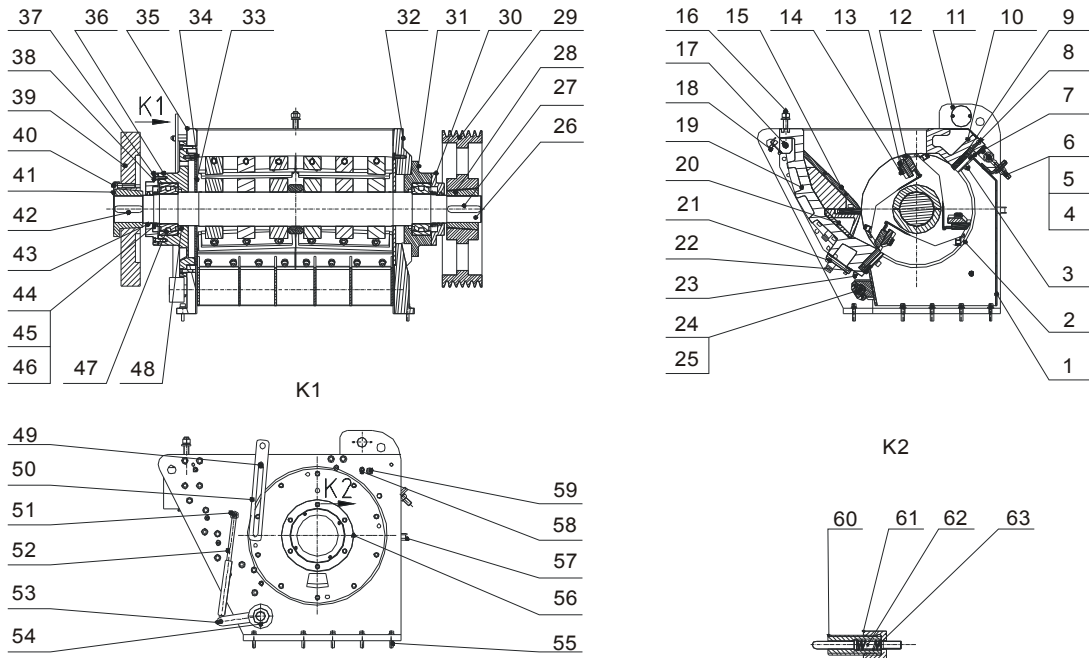

Note: Please refer to material list 4 about the parts code.

### 4. Parts List of Cutting Chamber Assembly

No.	Name	SG-5080(B)		SG-50110(B)	
		Parts No.	Qua.	Parts No.	Qua.
1	Screen bracket assembly	-	1	-	1
2	Screen $\Phi 12$ **		1		1
3	Inner hexagon cylindrical screw M16 $\times$ 65	YW61106500000	16	YW61106500000	20
4	Star screw	BH10501100540	4	BH10501100540	5
5	Shaft pin	BH10501100440	4	BH10501100440	5
6	A elastic ring for axes use 22	YW69002100000	4	YW69002100000	5
7	Front pressing block	BH11508000910	2	BH10501102110	2
8	Inner hexagon cylindrical screw M10 $\times$ 80	YW61108000000	4	YW61108000000	4
9	Fixed blade*	BW42508000010	4	BW42501100610	4
10	Front block	BW30508003210	1	BW30501102010	1
11	Hinge shaft	BH10509001410	2	BH10509001410	2
12	Rotating blade*	BW42508000110	6	BW42501100710	6
13	Pressing block of 3 rotating blades	BH11508001210	6	BH10501102610	6
14	Inner hexagon cylindrical screw M20 $\times$ 80	YW61208000000	18	YW61208000000	24
15	3 fixed blades device (optional)	-	1	-	1
16	Locking bolt of feed box	BH10508000710	1	BH10508000710	1
17	Hexagon bolt M20 $\times$ 100	YW60201000000	1	YW60201000000	1

18	Sensor*	YE15122400000	1	YE15122400000	1
19	Rear box block	BW30508000310	1	BW30501102810	1
20	Back-up plate of 3 fixed plate	BH11508001010	2	BH10501102910	2
21	Water cover plate	-	1	-	1
22	Rear pressing block	BH11508000210	2	BH10501103010	2
23	Inner hexagon socket set screw with flat point M16×16	YW61161600600	8	YW61161600600	8
24	Installation shaft sleeve of screen bracket	YW33509000000	2	YW33509000000	2
25	Installation shaft of screen bracket	BH10508001840	1	BH10501101710	1
26	Blade rest of 3 rotating blades	BH10508001910	1	BH10501102310	1
27	Flat key 28×137	BH11281370010	1	BH11281370010	1
28	Pulley taper sleeve	YW30501100000	1	YW30501100000	1
29	Large pulley	YW30224600000	1	YW30224600000	1
30	Right bearing cover	BW30509002110	1	BW30509002110	1
31	Right bearing base	BW30509002210	1	BW30509002210	1
32	Right block	BW30500400010	1	BW30500400010	1
33	Left and right material fender	YW45509002400	2	YW45509002400	2
34	Flat-head inner hexagon screw M12×30	YW61123000100	6	YW61123000100	6
35	Left block	BW30500700010	1	BW30500700010	1
36	Left bearing base	BW30509002710	1	BW30509002710	1
37	Left bearing cover	BW30500900010	1	BW30500900010	1
38	Inner hexagon cylindrical screw M12×40	YW61124000000	28	YW61124000000	28
39	Flywheel(optional)	BW30509003010	1	BW30509003010	1
40	Inner hexagon cylindrical screw M16×70(optional)	YW61167000000	6	YW61167000000	6
41	Flywheel taper sleeve(optional)	BW30509002910	1	BW30509002910	1
42	Flat key 28×117(optional)		1		1
43	Felt collar 120	-	2	-	2
44	Small nut M120×2	YW64120200000	2	YW64120200000	2
45	Stop gasket of round nut 120	YW09120000000	2	YW09120000000	2
46	Bearing gasket	-	2	-	2
47	NSK self-aligning roller bearing	YW11232200000	2	YW11232200000	2
48	Lip seal ring of bracket shaft	YR20161300000	2	YR20161300000	2
49	Lower hinge pin of connection plate	BH11501300210	1	BH11501300210	1
50	Machine side connection plate	-	1	-	1
51	Pneumatic spring pin	BH10509001210	1	BH10509001210	2
52	Gas spring	YW01180000300	1	YW01441600000	2
53	Gas spring swing arm	BH10509000210	1	BH10509000210	2
54	Inner hexagon cylindrical screw M10×40	YW09406500000	2	YW09406500000	2
55	Inner hexagon cylindrical screw M12×60	YW61260000000	10	YW61260000000	10

56	Connection forced filling oil cup	YW04010100000	2	YW04010100000	2
57	Aluminum square handle	BW20012000140	2	BW20012000140	2
58	Inner thread pneumatic spring pin	BH11050930010	12	BH11050930010	12
59	Inner hexagon cylindrical screw M16×60	YW61166000000	38	YW61166000000	38
60	Limit spring of screen bracket	YW01509003100	1	YW01509003100	1
61	Limit spring pin 3 of screen bracket	BH10509003210	1	BH10509003210	1
62	Limit spring pin 2 of screen bracket	BH10509003410	1	BH10509003410	1
63	Limit spring pin 1 of screen bracket	BH10509003310	1	BH10509003310	1

\* means possible broken parts. \*\* means easy broken part. and spare backup is suggested.

Please confirm the version of manual before placing the purchase order to guarantee that the item number of the spare part is in accordance with the real object.

## 5. Main Drive

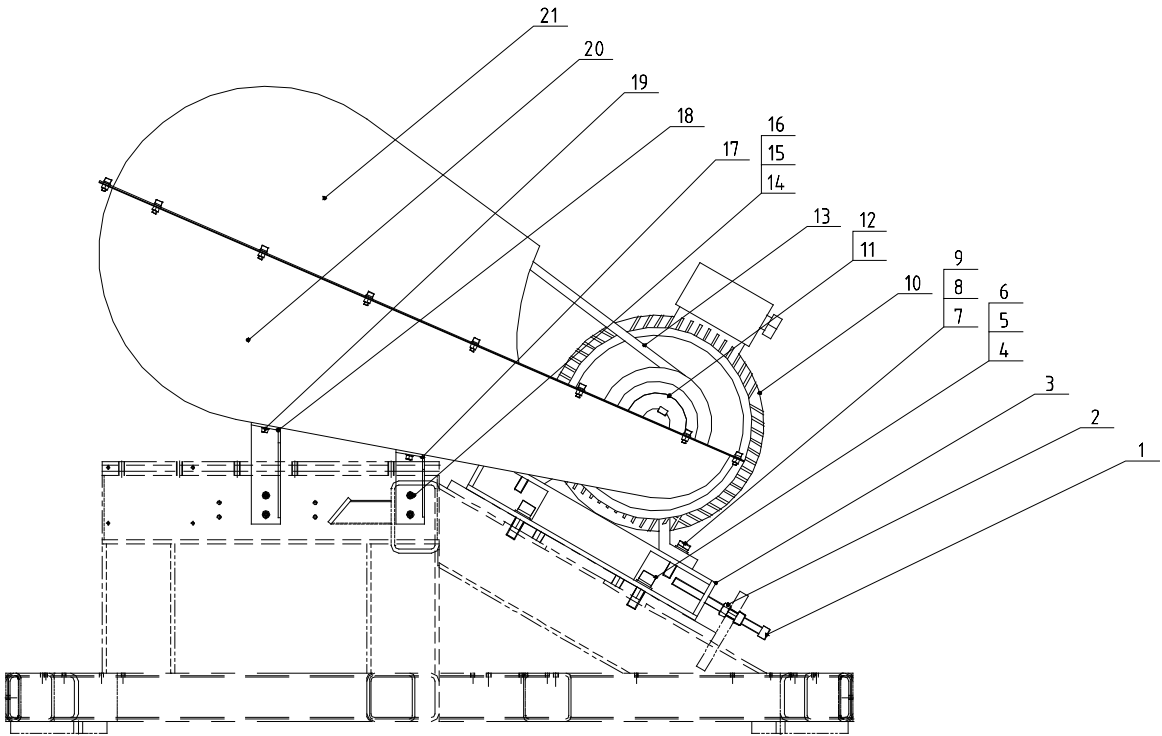

Note: Please refer to material list 6 about the parts code.

## 6. Parts List of Main Drive Assembly

No.	Name	SG-5080(B)		SG-50110(B)	
		Parts No.	Qua.	Parts No.	Qua.
1	Inner hexagon cylindrical screw M16x120	YW61161200300	4	YW61161200300	4
2	Hexagon nut M16	YW64001600000	4	YW64001600000	4
3	Motor mounting base	-	1	-	1
4	Hexagon bolt M16x70	YW60167000300	4	YW60167000300	4
5	Spring gasket 16	YW65016200000	4	YW65016200000	4
6	Flat washer 16	YW66164000000	4	YW66164000000	4
7	Hexagon bolt M20x60	YW60206000000	4	YW60206000000	4
8	Spring gasket 20	YW65020000000	4	YW65020000000	4
9	Flat washer 20	YW66203700000	4	YW66203700000	4
10	Motor	YM10000107300	1	YM10000107400	1
11	Small pulley	YW30224600000	1	YW30224600000	1
12	Motor taper sleeve	YW30353506000	1	YW30353506000	1
13	Narrow V belt*	YR00315000000	6	YR00315000000	6
14	Inner hexagon cylindrical screw M8x20	YW61082000200	4	YW61082000200	4

15	Spring gasket 8	YW65008000100	17	YW65008000100	17
16	Flat washer 8	YW66081900000	30	YW66081900000	30
17	Short bracket of pulley cover	-	1	-	1
18	Long bracket of pulley cover	-	1	-	1
19	Hexagon nut M8 anti-loose	YW64000800100	4	YW64000800100	4
20	Lower part of pulley cover	-	1	-	1
21	Upper part of pulley cover	-	1	-	1

\* means possible broken parts.

\*\* means easy broken part. and spare backup is suggested.

Please confirm the version of manual before placing the purchase order to guarantee that the item number of the spare part is in accordance with the real object.

## 7. Screen

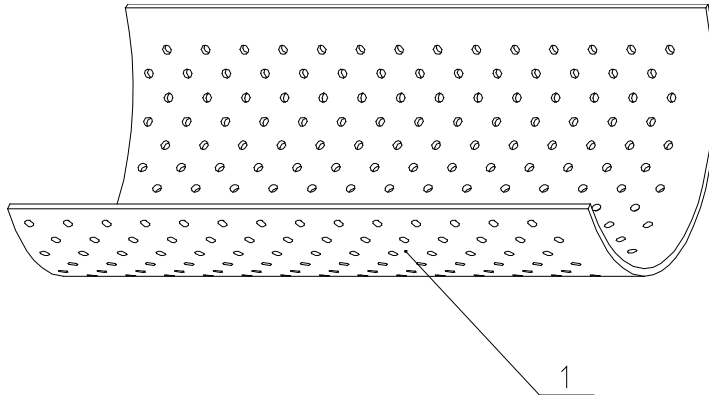

Note: Please refer to material list 8 about the parts code.

## 8. Screen Parts List

No.	Name	SG-5080B		SG-50110B	
		Parts No.	Qua.	Parts No.	Qua.
1	Screen $\Phi 12$ **	-	1	-	1

\* means possible broken parts. \*\* means easy broken part. and spare backup is suggested.



## 9. Screen Bracket

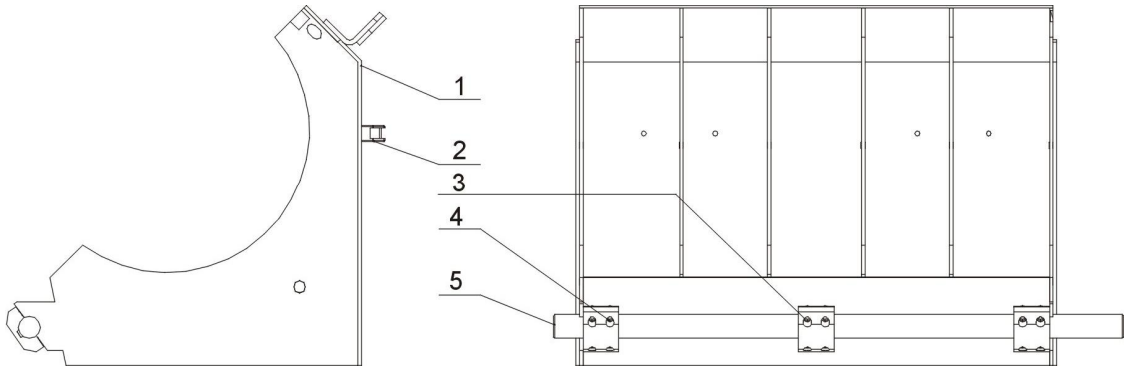

Note: Please refer to material list 10 about the parts code.

## 10. Parts List of Screen Bracket

No.	Name	SG-5080(B)		SG-50110(B)	
		Parts No.	Qua.	Parts No.	Qua.
1	Screen bracket body	-	1	-	1
2	Handle	YW20012000100	2	YW20012000100	2
3	Hinge pin hole seat of screen bracket	BH10508001310	3	BH10508001310	4
4	Inner hexagon cylindrical screw M8x20	YW61082000200	5	YW61082000200	5
5	Mounting shaft of screen bracket	BH10508001710	-	BH10501101710	-

Please confirm the version of manual before placing the purchase order to guarantee that the item number of the spare part is in accordance with the real object.

## 11. Material Conveyor Assembly

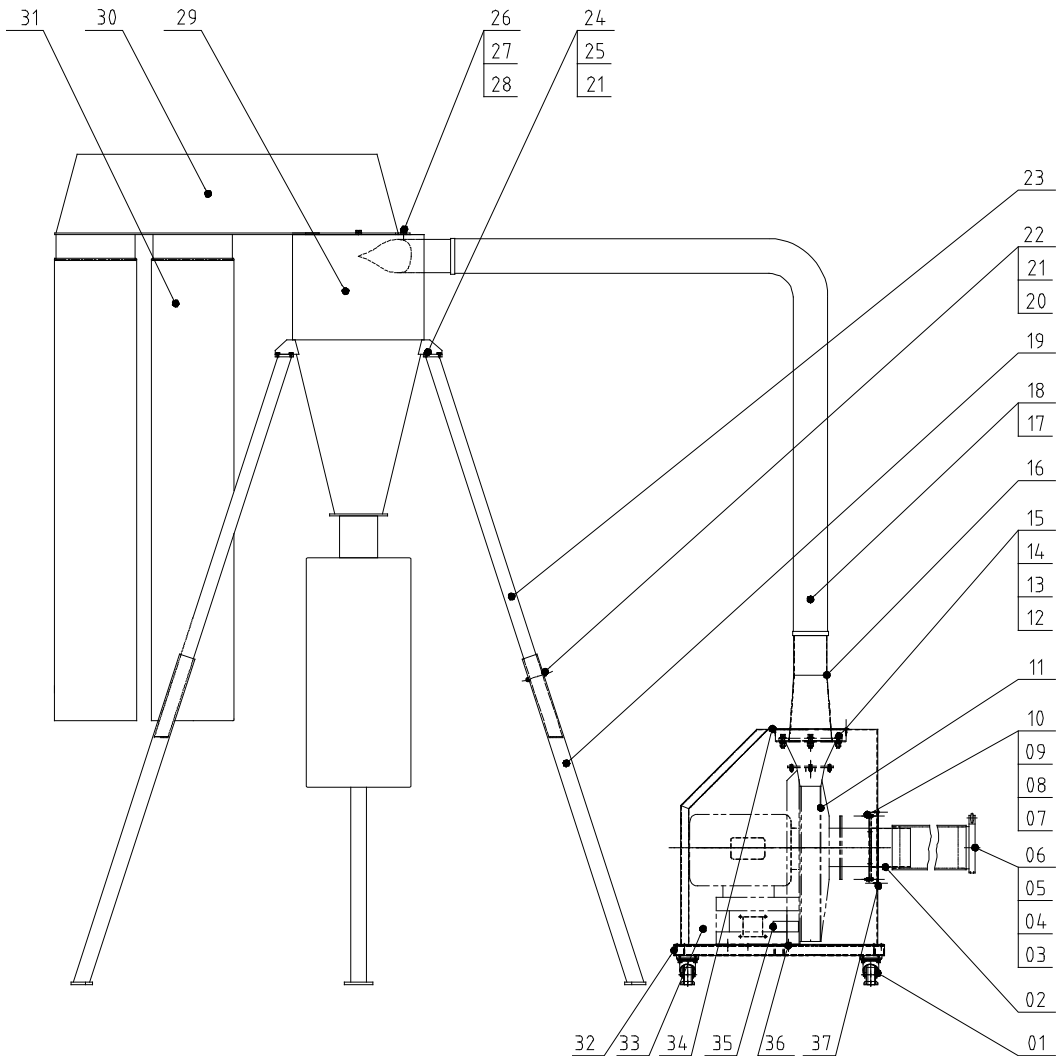

Note: Please refer to material list 12 about the parts code.

## 12. Parts List of Material Conveyor Assembly

No.	Name	SG-5080(B)		SG-50110(B)	
		Parts No.	Qua.	Parts No.	Qua.
1	Castor 3"(has anti-vibration pad)	YW03000301000	4	YW03000301000	4
2	Blower inlet connector	-	1	-	1
3	Steel wired plastic pipe 6"	YR60000600200	1.5m	YR60000600200	1.5m
4	Pipe clamp 6.5"	YW02006500000	2	YW02006500000	2
5	Stainless steel pipe clamp 6"	YW07000600000	1	YW07000600000	1
6	Pipe connector	-	1	-	1
7	Inner hexagon screw M6×20	YW61062000300	8	YW61062000300	8
8	Flat washer 6	YW66061300000	8	YW66061300000	8

9	Spring gasket 6	YW66061300000	8	YW66061300000	8
10	Hexagon nut M6	YW64000600300	8	YW64000600300	8
11	High pressure blower (400V)	BM30005500050	1	BM30005500050	1
12	Inner hexagon screw M12×50	YW61125000000	4	YW61125000000	4
13	Flat washer 12	YW66122400000	8	YW66122400000	8
14	Spring gasket 12	YW65012000000	8	YW65012000000	8
15	Hexagon nut M12	YW64012100000	8	YW64012100000	8
16	Blower outlet connector	-	1	-	1
17	Steel wired plastic pipe 5"	YR60000500000	4m	YR60000500000	4m
18	Pipe clamp 6"	YW02000600000	2	YW02000600000	2
19	Lower bracket	-	3	-	3
20	Inner hexagon cylindrical screw M8×80	YW61088000000		YW61088000000	
21	Flat washer 8	YW66081900000		YW66081900000	
22	Hexagon nut M8	YW64080600000		YW64080600000	
23	Upper bracket	-	3	-	3
24	Inner hexagon cylindrical screw M8×25	YW61082500100	3	YW61082500100	3
25	Spring gasket 8	YW65008000200	11	YW65008000200	11
26	Inner hexagon cylindrical screw M10×25	YW60102500100	3	YW60102500100	3
27	Flat washer 10	YW66102500000	3	YW66102500000	3
28	Spring gasket 10	YW65010000100	3	YW65010000100	3
29	Cyclone separator body	-	1	-	1
30	Outlet pipe of cyclone separator body	-	1	-	1
31	Cloth bag $\phi$ 314 × 1800	BP82313100044	2	BP82313100044	2
32	Blower base	-	1	-	1
33	Blower cover	-	1	-	1
34	Top cover	-	1	-	1
35	Embedded handle	YR90521300000	2	YR90521300000	2
36	Inner hexagon screw M12×35	YW61123500000	4	YW61123500000	4
37	Side cover plate	-	1	-	1

Please confirm the version of manual before placing the purchase order to guarantee that the item number of the spare part is in accordance with the real object.

### 13. Feed Box Assembly

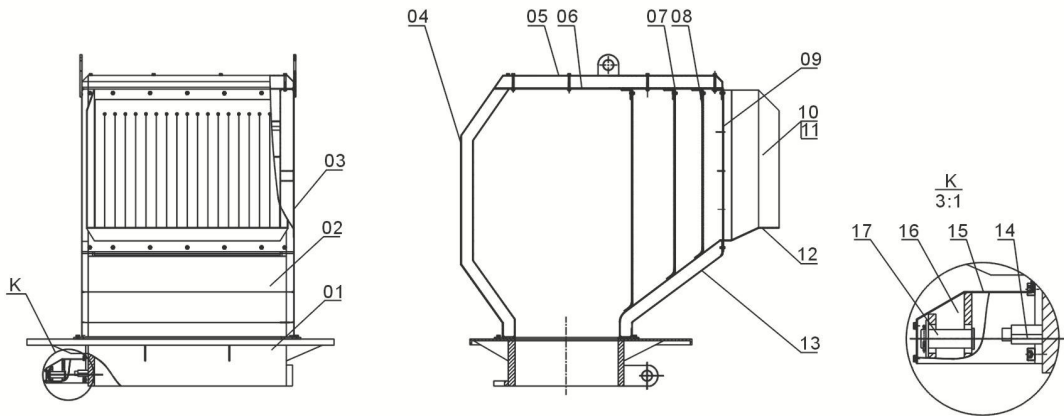

Note: Please refer to material list 14 about the parts code.

### 14. Parts List of Feed Box Assembly

No.	Name	SG-5080(B)		SG-50110(B)	
		Parts No.	Qua.	Parts No.	Qua.
1	Cutting chamber neck parts	-	1	-	1
2	Feed box body	-	1	-	1
3	Left or right side cover	-	2	-	2
4	Rear cover plate	-	1	-	1
5	Upper top plate	-	1	-	1
6	Upper side plate	-	1	-	1
7	Pressing block	-	3	-	3
8	Plastic curtain *	-	3	-	3
9	Feed box frame	-	1	-	1
10	Left side plate of feed port	-	1	-	1
11	Left side plate of feed port	-	1	-	1
12	Feed port bottom plate	-	1	-	1
13	Front cover plate	-	1	-	1
14	Upper hinge of connectionplate	BH11500200210	1	BH11500200210	1
15	Hinge pin of electronic handspike	-	1	-	1
16	Hinge-pin shaft of electronic handspike	-	1	-	1
17	Hinge pin of electronic handspike	BH10500002142	1	BH10500002142	1

Please confirm the version of manual before placing the purchase order to guarantee that the item number of the spare part is in accordance with the real object.

## 15. Storage Box

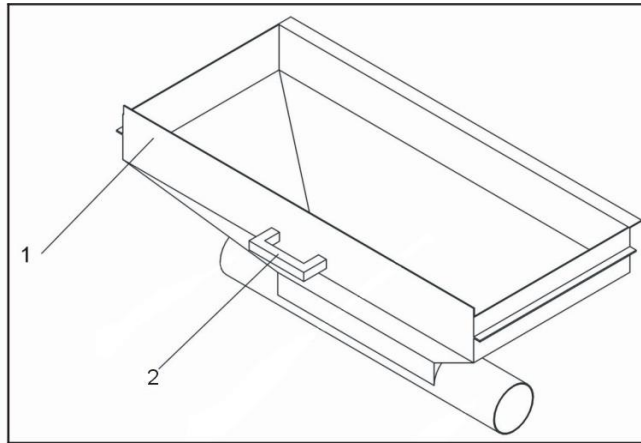

Note: Please refer to material list 16 about the parts code.

## 16. Parts List of Storage Box

No.	Name	SG-5080(B)		SG-50110(B)	
		Parts No.	Qua.	Parts No.	Qua.
1	Storage box	-	1	-	1
2	Aluminum square handle	BW20012000140	1	BW20012000140	1

Please confirm the version of manual before placing the purchase order to guarantee that the item number of the spare part is in accordance with the real object.

## 17. Rack Assembly

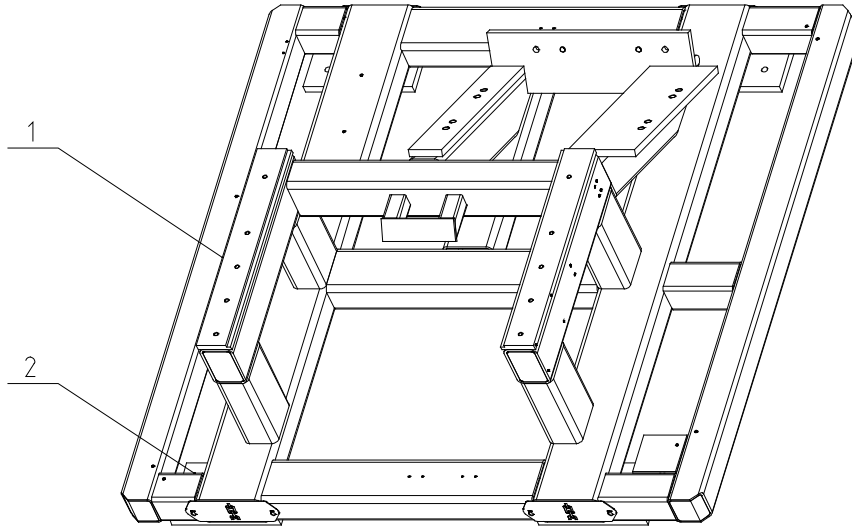

Note: Please refer to material list 18 about the parts code.

## 18. Part List of Rack Assembly

No.	Name	SG-5080(B)		SG-50110(B)	
		Parts No.	Qua.	Parts No.	Qua.
1	Rack	-	1	-	1
2	Anti-vibration pad	YW03162000000	4	YW03162000000	4

Please confirm the version of manual before placing the purchase order to guarantee that the item number of the spare part is in accordance with the real object.

## 19. Electronic Handspike

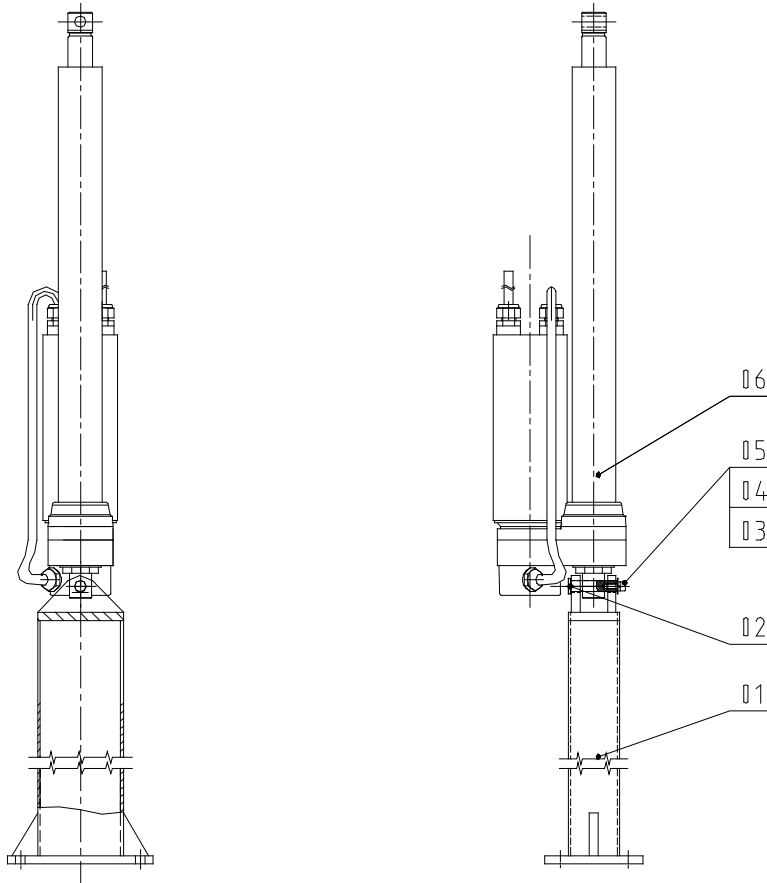

Note: Please refer to material list 20 about the parts code.

## 20. Parts List of Electronic Handspike

No.	Name	SG-5080(B)		SG-50110(B)	
		Parts No.	Qua.	Parts No.	Qua.
1	Installation base	-	1	-	1
2	Lower hinge pin of electronic handspike	BH10500002042	1	BH10500002042	1
3	Inner hexagon cylindrical screw M6×16	YW61061600200	1	YW61061600200	1
4	Big gasket $\Phi 18/\Phi 6$	YW66061800000	1	YW66061800000	1
5	Standard spring washer 6	YW65006000100	1	YW65006000100	1
6	Electronic handspike	YM90305600000	1	YM90305600000	1

Please confirm the version of manual before placing the purchase order to guarantee that the item number of the spare part is in accordance with the real object.

## 21. Dust Separator System

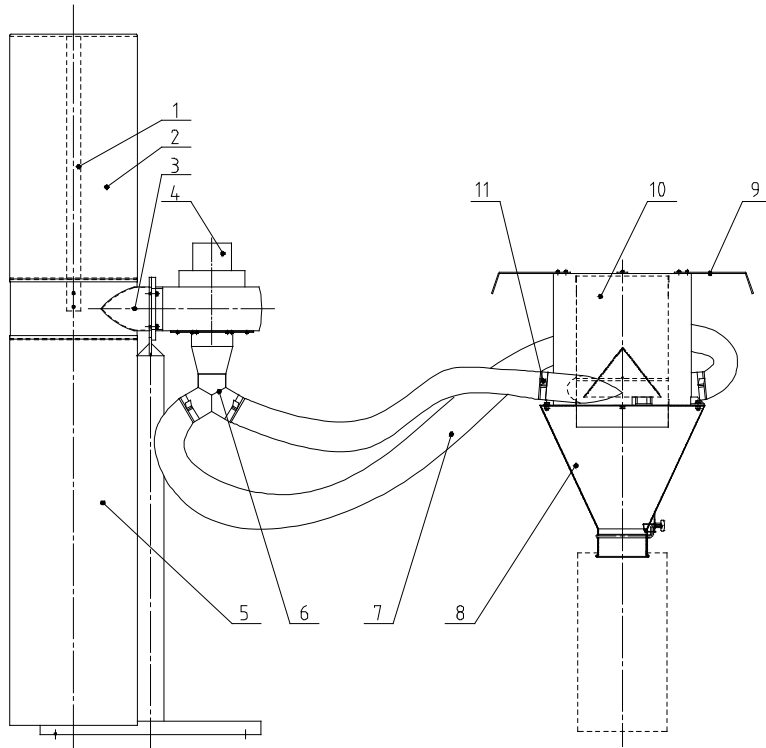

Note: Please refer to material list 22 about the parts code.

## 22. Parts List of Cyclone and Dust Separator

No.	Name	SG-5080(B)		SG-50110(B)	
		Parts No.	Qua.	Parts No.	Qua.
1	Cloth bag frame 1	-	1	-	1
2	Filter cloth bag 2( gauze 450)	BP82464600144	1	BP82464600144	1
3	Blower and cloth bag frame	-	1	-	1
4	Blower	YM40006000300	1	YM40006000300	1
5	Filter cloth bag 1(cotton)	BP82464600244	1	BP82464600244	1
6	Blower cover	-	1	-	1
7	4" Wired hosex3m	YR60000400100	2	YR60000400100	2
8	Discharge hopper of dust separator	-	1	-	1
9	Tension strip	-	3	-	3
10	Big and small hopper of dust separator	-	1	-	1
11	Stainless steel pipe clamp 5"	YW02000500000	4	YW02000500000	4

Please confirm the version of manual before placing the purchase order to guarantee that the item number of the spare part is in accordance with the real object.



## 23. Soundproof Box Assembly

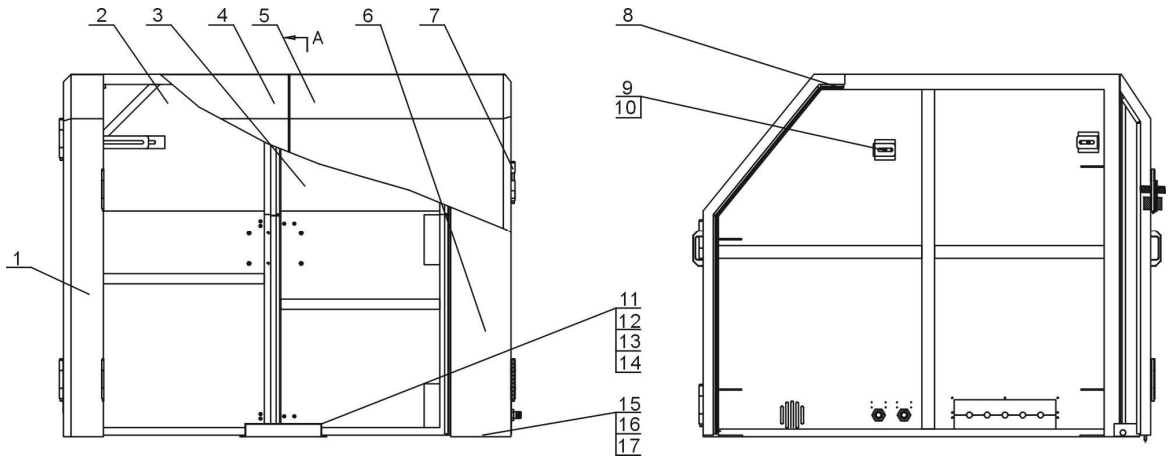

Note: Please refer to material list 24 about the parts code.

## 24. Parts List of Soundproof Box Assembly

No.	Name	SG-5080		SG-50110	
		Parts No.	Qua.	Parts No.	Qua.
1	Left cover	-	1	-	1
2	Rear right door	-	1	-	1
3	Rear left door	-	1	-	1
4	Front left door	-	1	-	1
5	Front right door	-	1	-	1
6	Right cover	-	1	-	1
7	Hinge pin	-	8	-	8
8	Tri-material compound sealing tape lx011	YR10011000100	7.1m	YR10011000100	7.1m
9	Cover fixed plate	-	8	-	8
10	Hexagon nut M12	YW64012100000	8	YW64012100000	8
11	Safety switch cover	-	1	-	1
12	Cross recessed pan head screw M5x10	YW62051000100	4	YW62051000100	4
13	Flat washer 5	YW66051000000	4	YW66051000000	4
14	Spring washer 5	YW65005200000	4	YW65005200000	4
15	Inner hexagon column screw M8x20	YW61082000200	8	YW61082000200	8
16	Flat washer 8	YW66081600000	8	YW66081600000	8
17	Spring washer 8	YW65008000200	8	YW65008000200	8

Please confirm the version of manual before placing the purchase order to guarantee that the item number of the spare part is in accordance with the real object.

## 25. Control box

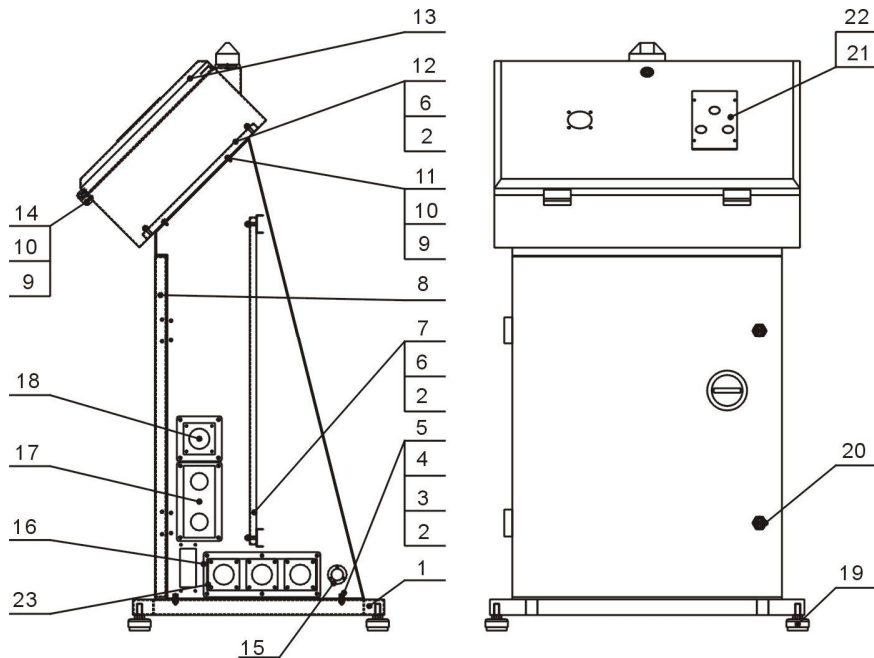

Note: Please refer to material list 26 about the parts code.

## 26. Parts List of Control Box

No.	Name	SG-5080(B)		SG-50110(B)	
		Parts No.	Qua.	Parts No.	Qua.
1	Control box base	-	1	-	1
2	Flat washer 6	YW66061300000	12	YW66061300000	12
3	Spring washer 6	YW65006000100	4	YW65006000100	4
4	Hexagon column screw M6x16	YW61061600200	4	YW61061600200	4
5	Control box body	-	1	-	1
6	Hexagon nut M6	YW64000600300	8	YW64000600300	8
7	Electrical component installation plate 1	-	1	-	1
8	Control box door plate	-	1	-	1
9	Flat washer 5	YW66051000000	38	YW66051000000	38
10	Cross recessed pan head screw M5x10	YW62051000100	38	YW62051000100	38
11	Control box body	-	1	-	1
12	Electrical component installation plate 2	-	1	-	1
13	Control box cover	-	1	-	1
14	Big hinge CL219-1	YW06219100000	4	YW06219100000	4
15	Cover plate 1	-	1	-	1
16	Wire clamp fixed plate 1	-	1	-	1
17	Wire clamp fixed plate 2	-	1	-	1

18	Wire clamp fixed plate 3	-	1	-	1
19	Anti-vibration pad $\varnothing 50$	YW03005000000	4	YW03005000000	4
20	Door lock (MS816-1 black, with key )	YW00816100000	3	YW00816100000	3
21	Nameplate SG-16	BR01016000020	1	BR01016000020	1
22	Cross recessed pan head screw M4*10	YW62041000000	4	YW62041000000	4
23	Cover plate 2	-	3	-	3

Please confirm the version of manual before placing the purchase order to guarantee that the item number of the spare part is in accordance with the real object.

## 27. Belt Conveyor

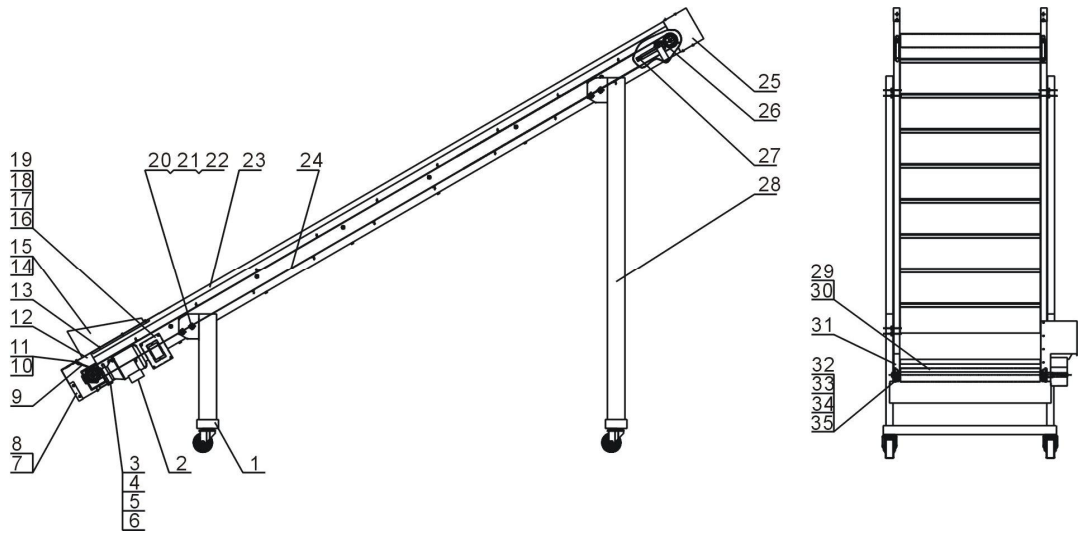

Note: Please refer to material list 28 about the parts code.

## 28. Parts List of Belt Conveyor Assembly

No.	Name	SG-5080(B)		SG-50110(B)	
		Parts No.	Qua.	Parts No.	Qua.
1	Base 1	-	1	-	1
2	Gear motor 0.2kW(JCSS)	YM50102500000	1	YM50102500000	1
3	Motor bracket	-	1	-	1
4	Hexagon bolt M8x25	YW60082500300	2	YW60082500300	2
5	Hexagon nut M8	YW64000800100	2	YW64000800100	2
6	Flat washer 8	YW66081600000	4	YW66081600000	4
7	Rear close plate	-	1	-	1
8	Cross recessed pan head screw M6 x 15	YW62061500000	4	YW62061500000	4
9	Baffle plate	-	1	-	1
10	Pressing plate	-	1	-	1
11	Open lenticular head blind rivet 4x10	YW69041000100	9	YW69041000100	9
12	End face cover plate 2	-	1	-	1
13	Hexagon tapping screw ST6.3 x 19	YW66061210000	17	YW66061210000	17
14	Material fender	-	1	-	1
15	Cross recessed pan head screw M5X5	YW62050500000	4	YW62050500000	4
16	Regulator cover	-	1	-	1
17	Regulator cover plate	-	1	-	1
18	Lenticular head screw M4x8	YW62040800000	6	YW62040800000	6
19	Lenticular head screw M5x15	YW62051500000	4	YW62051500000	4

20	Hexagon bolt M12 x 25	YW60122500100	8	YW60122500100	8
21	Flat washer 12	YW66122400000	16	YW66122400000	16
22	Hexagon nut M12	YW64012100000	8	YW64012100000	8
23	Conveyor main body bracket	-	1	-	1
24	Conveyor belt with barrier	-	1	-	1
25	End face cover plate 3	-	2	-	2
26	Iron roll	-	1	-	1
27	Butterfly screw	-	2	-	2
28	Base 2	-	1	-	1
29	Conveying rotor	-	1	-	1
30	Flat key C6x70	BH10506700010	-	BH10506700010	-
31	End face cover plate 1	-	1	-	1
32	Bearing base assembly	YW11205100100	2	YW11205100100	2
33	Flat washer 10	YW66102500000	8	YW66102500000	8
34	Hexagon locknut M10	YW64101100000	4	YW64101100000	4
35	Hexagon bolt M10x30	YW60103000100	5	YW60103000100	5

Please confirm the version of manual before placing the purchase order to guarantee that the item number of the spare part is in accordance with the real object.

## 29. Presetting Knife Jig

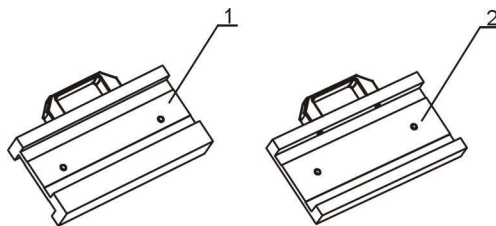

Note: Please refer to material list 30 about the parts code.

## 30. Parts List of Presetting Knife Jig

No.	Name	SG-5080(B)		SG-50110(B)	
		Parts No.	Qua.	Parts No.	Qua.
1	Presetting knife jig of five rotating blades	BH10501103310	1	BH10501103310	1
2	Presetting knife jig of three rotating blades	BH10508000010	1	BH10508000010	1

Please confirm the version of manual before placing the purchase order to guarantee that the item number of the spare part is in accordance with the real object.