

Assembly Drawing and Parts List SAL-2HP-UG124

机型版本号 Ver.D

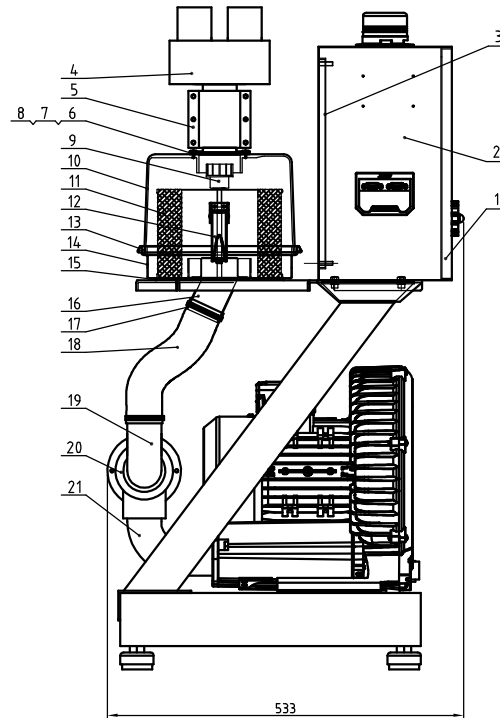
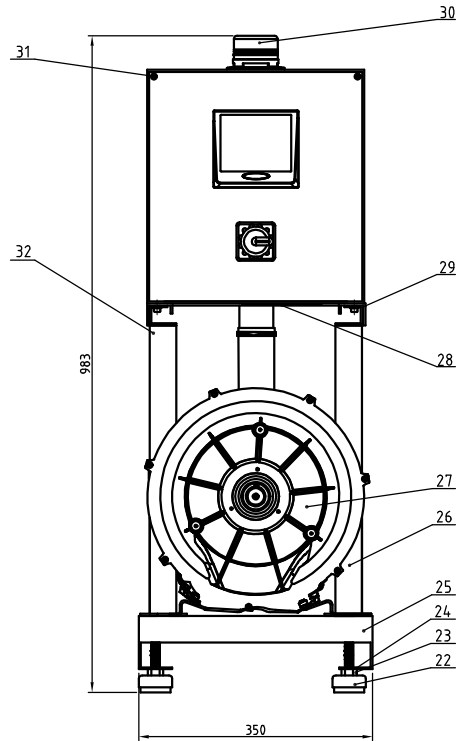

Tech. Req:

1. Main performance parameters:

a. The output is 550kg/hr (the data is obtained under the test standard of materials' bulk density in diameter of 0.65kg/L, plastic particle diameter 3-5m, vertical height of 4 m, and horizontal distance of 5m).

b. Conveying pipe diameter: 1.5inch, suction air pipe diameter: 2inch, host unit weight: 60KG;

c. Machine power: 3phase, 400VAC, 50Hz;

d. Machine high pressure blower power: 1.5 (3φ) kW;

e. Pneumatic working pressure: 0.4-0.8MPa.

f. Used with four SHR-3U-S hoppers. The single hopper capacity is 3L, and the single hopper weight is 4.5KG.

2. "x" indicates the items that may be damaged; "x x" indicates the items that are more likely to be damaged. It is recommended to back them up.

Please confirm the version number of the instruction manual before placing an order to purchase spare parts, so as to ensure that the material number of spare parts is consistent with the physical one.

32		Left column	Assembly	1	
31	YW67050800000	Cross recessed pan head self-tapping lock screw Ø6MM*6Longtin		2	
30	BL90000011520	Three color alarm light (red, yel. gr. + buzzer) AC/DC24. #	Assembly	1	
29		Filter hopper fixed frame	SPCC3.0	1	
28	BL50135000020	Wire clamp fixed plate PG13.5 SG-S-01	SPCC2.0	1	
27	BM30042000050	Shini blower RB-420/2HP3 phase black*	Assembly	1	
26		Right column	Assembly	1	
25		Base	SPCC3.0	1	
24	YW64.012100000	Hex. nut GB/T6170 M12-Longzine		4	
23	YW66082200100	Large washer C grade GB/T9688.4x24x21-Longzine		4	
22	YW03005000000	Foel pad rubber φ50 small	Rubber	4	
21		Air inlet pipe	SUS201	1	
20	BY20003800300	Vacuum breaking separating valve SVBV-38-24VDC#	Assembly	1	
19		Connecting pipe	SUS201	1	
18	YR60500700100	Steel wire hose 2"*	Assembly	0.7m	
17	YW02006500100	Stainless steel pipe clamp φ5mm	Assembly	2	
16		Filter hopper base	Welding parts	1	
15	YR10080000000	Fastener SAL-810G-A-04(ver.0) rubber (black) #	Rubber	1	
14		Filter hopper cover	SPCC1.2	1	
13	YR100800000300	Filter hopper fastener SAL-810G-A-03*	Rubber	1	
12	YW02003000400	Spring SAL-6U-A-35*	Assembly	2	
11	YR50708000100	Filter SAL-700G/800G fastener*	Assembly	1	
10	YL22081000000	Transparent filter barrel SAL-810G-A-05(ver.0)#	PC	1	
9	YW09675100000	Star nut 5/16 SHD-6~75KG-01-SJ alu. alloy		1	
8	YW6204.1200000	Large cross recessed flat head #5!!!! M4x12-Longzine		4	
7	YR1024.3600000	Suction pipe round fastener SAL-24U/36U*	Rubber	1	
6		Filter hopper suction port	SUS201	1	
5	BW20002002050	Aluminum nozzle 2"	YL112	1	
4		Three way pipe	SUS201	1	
3		Control bottom plate	SECC15	1	
2		Control box body	SPCC15	1	
1		Control box cover plate	SPCC15	1	

制图	版号	标题	图号	比例	数量	备注
设计	核准	SAL-2HP-UG124	SAL-2HP-UG124-ALL	1:6	1	
校对	核准	一对四分式真空填料机		材质	组件	
标记	更改前	更改后	更改人	日期	审核	日期
			SHINI 信昌电热机械股份有限公司 Shini Plastics Technologies, Inc.		表面要求 物料号	

Attached: SVBV-38 assembly diagram and parts List(BY20003800300).

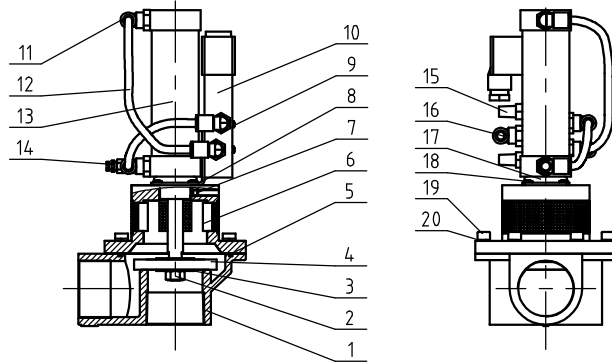

"\*"Indicates the items that may be damaged; "\* \*" indicates the items that are more likely to be damaged.  
It is recommended to back them up.  
Please confirm the version number of the instruction manual before placing an order to purchase spare parts, so as to ensure that the material number of spare parts is consistent with the physical one.

20	YW65006000100	Standard spring washer GB/T93 6-Longzine		6	
19	YW61062000300	Inner hex column head screw GB/T70.1 M6x20-12.9-Longzine		6	
18	YW63040600000	Cross recessed pan head screw M4x6		4	
17	YR20305000000	O rubber seal ring $\phi 30 \times \phi 5^*$	Rubber	1	
16	YW80081800100	L screw connector APL8-01 1/8- $\phi 8$	Assembly	1	
15	YW80010800000	Copper silencer 1/8 (has mould)	Assembly	2	
14	YW80061800000	Adjustable air pipe connector ASL6-1/8	Assembly	1	
13	YE31326000100	Cylinder MBL32x60U (AIRTAC) *	Assembly	1	
12	YR60000600400	PU air pipe $\phi 6$ blk 200m/roll	PU	0.3m	
11	YW80061800200	L screw connector APL6-01 1/8- $\phi 6$	Assembly	3	
10	YE32421000300	Solenoid valve 4V210-06/DC24V Air-TAC*	Assembly	1	
9	YW63043500000	Cross recessed pan head screw GB/T-818 M4x35-Longzine		2	
8	BL20380500020	Solenoid valve fixed piece SPDV-38-ALL-05	SPCC2.0	1	
7	YW68005500000	Inner hex. flat end lock screw GB/T77 M5x5-Longzine		1	
6	BW20380100010	Upper cover SVBV-38-ALL-01	Assembly	1	
5	YR20258900000	O rubber seal ring 2.5x89(ext. dia.) *	Rubber	1	
4	BR10651200040	Four way valve diaphragm 65x12x8mm film covered (has mould)*	Assembly	1	
3	YW66103200000	Large washer A grade GB/T96 1010.5x30x2.5)-Longzine		2	
2		Hex nut M10x1.25		1	with cylinder
1	BW20001500910	Lower cover SPDV-38-ALL-02 white	YL112	1	
序号	代号	名称	材质	数量	备注

					制图	版号	标题	SVBV-38	图号	SVBV-38-ALL	比例	1:4	数量	1
					设计	核准		破真空分离阀						
					校对									
					审核	日期								
标记	更改前	更改后	更改人	日期										
 信易智能机械股份有限公司 Shini Plastic Technologies, Inc.											表面要求			
											物料号			

Assembly Drawing and Parts List SAL-3HP-UG124

机型版本号 Ver.C

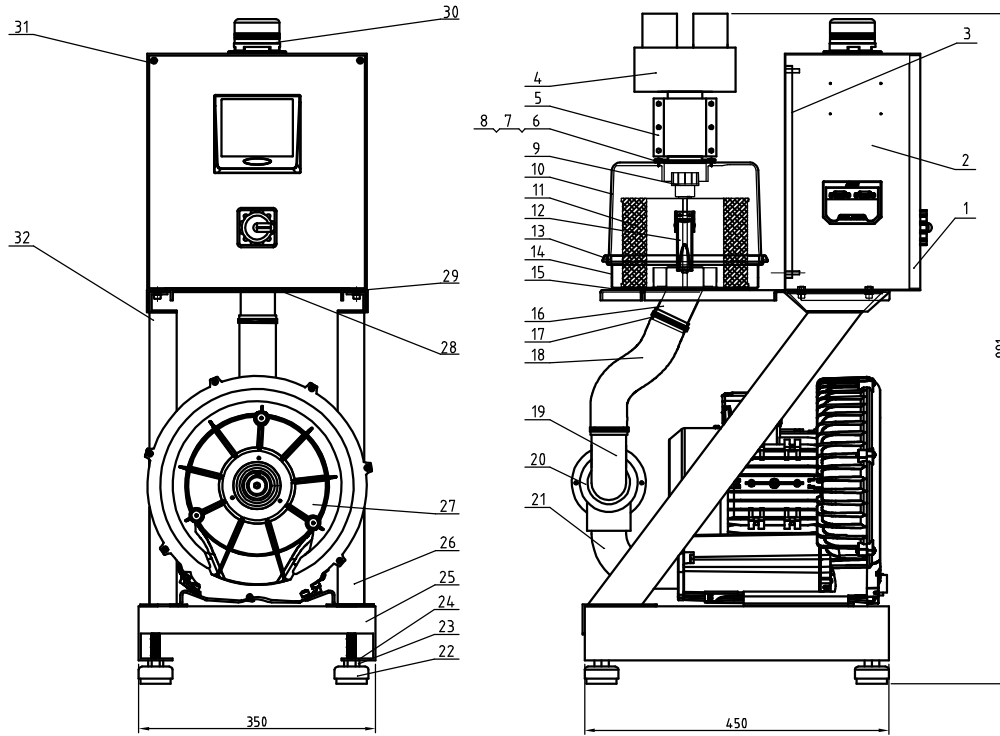

Tech. Req.

1.Main performance parameters:

- a. The output is 800kg/hr (the data is obtained under the test standard of materials' bulk density in diameter of 0.65kg/L, plastic particle diameter 3-5m, vertical height of 4 m, and horizontal distance of 5m).
- b. Conveying pipe diameter: 1.5inch, suction air pipe diameter: 2inch, host unit weight: 65KG;
- c. Machine power: 3phase,400VAC, 50Hz;
- d. Machine high pressure blower power: 1.85 (3φ) kW;
- e. Pneumatic working pressure: 0.4-0.8MPa.
- f. Used with four SHR-6U-S hoppers. The single hopper capacity is 6L, and the single hopper weight is 7.5KG.

2. "\*" indicates the items that may be damaged; "x x" indicates the items that are more likely to be damaged. It is recommended to back them up.  
Please confirm the version number of the instruction manual before placing an order to purchase spare parts, so as to ensure that the material number of spare parts is consistent with the physical one.

序号	代号	名称	材质	数量	备注
32		Left column	Assembly	1	
31	YW67050800000	Cross recessed pan head self-tapping lock screw GB6170 M4-Longzine		2	
30	BL90000011520	Three color alarm light red, yel. gre. + buzzer1 AC/DC24. Ⓢ	Assembly	1	
29		Filter hopper fixed frame	SPCC3.0	1	
28	BL50135000020	Wire clamp fixed plate PG13.5 SG-S-01	SPCC2.0	1	
27	BM30053000050	Shini blower RB-430 small 3P/185kw/ 3phase blk.*	Assembly	1	
26		Right column	Assembly	1	
25		Base	SPCC3.0	1	
24	YW64.012100000	Hex. nut GB/T6170 M12-Longzine		4	
23	YW66082200100	Large washer C grade GB/T96818.4x24x21-Longzine		4	
22	YW03005000000	Foot pad rubber #50 small	Rubber	4	
21		Air inlet pipe	SUS201	1	
20	BY200038000300	Vacuum breaking separating valve SVBV-38-24VDC*	Assembly	1	
19		Connecting pipe	SUS201	1	
18	YR60500700100	Steel wire hose 2"*	Assembly	0.7m	
17	YW02006500100	Stainless steel pipe clamp 65mm	Assembly	2	
16		Filter hopper base	Welding parts	1	
15	YR10080000000	Fastener SAL-810G-A-04. Ⓢ	Rubber	1	
14		Filter hopper cover	SPCC1.2	1	
13	YR100800000300	Filter hopper fastener SAL-810G-A-03*	Rubber	1	
12	YW020030004.00	Spring buckle SAL-6U-A-35*	Assembly	2	
11	YR50708000100	Filter SAL-700G/800G fastener *	Assembly	1	
10	YL22081000000	Transparent filter barrel SAL-#9G-A-#5(ver.01has mold)*	PC	1	
9	YW09675100000	Star nut 5/16 SHD-6~75KG-01-SJ alu. alloy		1	
8	YW6204.1200000	Large cross recessed flat head JIS1111 M4x12-Longzine		4	
7	YR10243600000	Suction pipe round fastener SAL-24U/36U*	Rubber	1	
6		Filter hopper suction port	SUS201	1	
5	BW20002002050	Aluminum nozzle 2"	YL112	1	
4		Three way pipe	SUS201	1	
3		Control bot tom plate	SECC1.5	1	
2		Control box body	SPCC1.5	1	
1		Control box cover plate	SPCC1.5	1	

制图	版号	设计	核	校	准	日期	日期
标记	更改前	更改后	更改人	日期	审核	日期	

标题 SAL-3HP-UG124  
对四分式美空集料机

图号 SAL-3HP-UG124-ALL

比例 1:6

数量 1

材质 组件

表面要求

物料号

信易电热机械股份有限公司  
Shini Plastics Technologies, Inc.

Attached: SVBV-38 assembly diagram and parts List(BY20003800300).

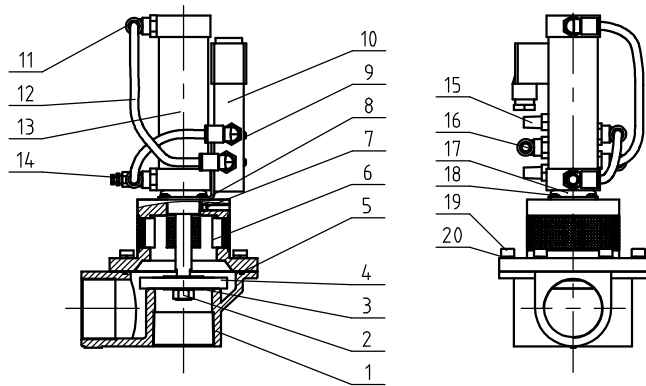

"\*"Indicates the items that may be damaged; "\*\* \*" indicates the items that are more likely to be damaged.  
 It is recommended to back them up.  
 Please confirm the version number of the instruction manual before placing an order to purchase spare parts, so as to ensure that the material number of spare parts is consistent with the physical one.

20	YW65006000100	Standard spring washer GB/T93 6-Longzine		6	
19	YW61062000300	Inner hex column head screw GB/T70.1 M6x20-12.9-Longzine		6	
18	YW63040600000	Cross recessed pan head screw M4x6		4	
17	YR20305000000	O rubber seal ring $\phi 30 \times \phi 5^*$	Rubber	1	
16	YW80081800100	L screw connector APL8-01 1/8- $\phi 8$	Assembly	1	
15	YW80010800000	Copper silencer 1/8 (has mould)	Assembly	2	
14	YW80061800000	Adjustable air pipe connector ASL6-1/8	Assembly	1	
13	YE31326000100	Cylinder MBL32x60U (AIRTAC) *	Assembly	1	
12	YR60000600400	PU air pipe $\phi 6$ blk 200m/roll	PU	0.3m	
11	YW80061800200	L screw connector APL6-01 1/8- $\phi 6$	Assembly	3	
10	YE32421000300	Solenoid valve 4V210-06/DC24V Air-TAC*	Assembly	1	
9	YW63043500000	Cross recessed pan head screw GB/T-818 M4x35-Longzine		2	
8	BL20380500020	Solenoid valve fixed piece SPDV-38-ALL-05	SPCC2.0	1	
7	YW68005500000	Inner hex. flat end lock screw GB/T77 M5x5-Longzine		1	
6	BW20380100010	Upper cover SVBV-38-ALL-01	Assembly	1	
5	YR20258900000	O rubber seal ring 2.5x89(ext. dia.) *	Rubber	1	
4	BR10651200040	Four way valve diaphragm 65x12x8mm film covered (has mould)**	Assembly	1	
3	YW66103200000	Large washer A grade GB/T96 1010.5x30x2.51-Longzine		2	
2		Hex nut M10x1.25		1	with cylinder
1	BW20001500910	Lower cover SPDV-38-ALL-02 white	YL112	1	
序号	代号	名称	材质	数量	备注

					制图	版号	标题	图号	比例	1:4	数量	1
					设计	核准	破真空分离阀	SVBV-38-ALL		材质	组件	
					校对					表面要求		
标记	更改前	更改后	更改人	日期	审核	日期	信易電熱機械股份有限公司 Shini Plastics Technologies, Inc.		物料号			

机器装配图与装配材料明细表SAL-5HP-UG124

机型版本号: Ver.F

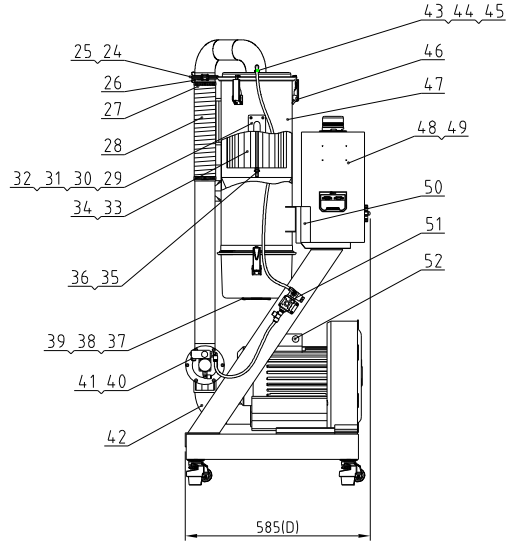
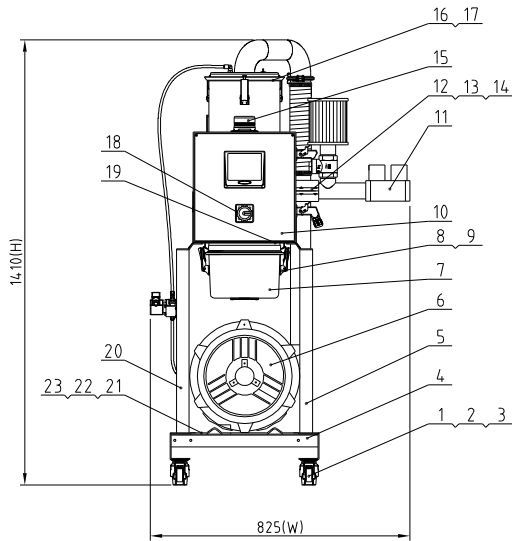

Technical requirements.

1.Main Parameters.

- a The output is 1200kg/hr (the data is obtained under the best standard of materials' bulk density in diameter of 0.65kg/L, plastic particle diameter 3-5m, vertical height of 4 m, and horizontal distance of 5m)
- b Conveying pipe diameter:1.5inch. Air suction pipe diameter:2inch.
- c SAL-5HP-UG124 host unit weight is 175KG.
- d SAL-5HP-UG124 high pressure blower power is 3.75 (3φ) kW.
- e Pneumatic working pressure 0.4-0.8MPa.

2."\*"Indicates the items that may be damaged; "\*\*" indicates the items that are more likely to be damaged. It is recommended to back them up.

Please confirm the version number of the instruction manual before placing an order to purchase spare parts, so as to ensure that the material number of spare parts is consistent with the physical one.

46	YW69050100000	Open flat round head blind rivet GB/T12618 4x4		6	
45	YR60000800000	PU air pipe Φ8×Φ6 black 100M/roll*		18m	
44	BH13033000810	Reverse cleaning pipe nozzle SAL-330-A-08	6061	1	
43	YW80083800200	L thread connector AP18-03 3/8-08	Assembly	1	
42		Air inlet pipe	SUS201	1	
41		Vacuum breaking diaphragm valve pipe	SUS201	1	
40	BY20005000300	Vacuum breaking diaphragm valve SVBV-50-24VDC*	Assembly	1	
39	YW62041200000	Large cross socket flat head screw M6x12-L-Longzme		4	
38	YR10243600000	Suction pipe round fastener SAL-24U/36U*	Rubber	1	
37		Transparent filter barrel fender	SUS201	1	
36	YW66082200100	Large washer C grade GB/T96 818 4x24x21-Longzme		1	
35	YW69051600000	Butterfly nut 5/16"	Q235	1	
34		Filter fixing plate	SECC2.0	1	
33	YR50181100000	Filter ADC2 rubber fastener**	Assembly	1	
32	YW62051000100	Large cross socket flat head screw JIS1111 M5x10-Longzme		4	
31	BW090000304.0	Arc 4-hole iron plate electroplate	Q235	1	
30	YR4.0004.00000	Sight glass fastener four hole (SHD-12-A-56)*	Rubber	1	
29	YR4.0001200100	Acryl 4-hole (SHD-12-A-55)*	PC	1	
28	YR60002500000	Steel wire hose 2.5"(PUR355)*	PUR355	0.3m	
27	YW20007600000	Steel wire pipe 76mm		2	
26		Air suction pipe	Assembly	1	
25	YR20002500300	Stainless steel pressing clamp seal ring 2.5"*	Silical gel	1	
24	YW07002501600	Stainless steel stamping clamp 2.5"	Assembly	1	
23	YW66103200000	Large washer A grade GB/T96 1010 5x30x2.51-Longzme		4	
22	YW64101100000	Hex nut M10 anti-loose (thickness 11mm)		4	
21	YW61102000000	Inner hexagon column screw GB/T701 M10x20-12.9-Longzme		4	
20		Left column	Assembly	1	
19	BL50135000020	Wire clamp fixed plate PG135 SG-S-01has (material)	SPCC2.0	1	
18	YE10021160000	Main power switch TO-2-1/EA/SVB/20(AEATON)	Assembly	1	
17	YR10080000300	Filter barrel fastener SAL-810G-A-03(Ver.A)**	Nitrile rubber	2	
16		Filter hopper cover assembly	Assembly	1	
15	BL90000011520	Three color alarm light (red, yel, green, buzzer)*	Assembly	1	
14	YR50128200000	Suchron box filter SP-F ext 128x28x148*	Assembly	1	
13	YW59150000000	Check valve 15" (copper)	Assembly	1	
12	BW20002002050	Aluminum pipe coupler 2"	Assembly	1	
11		Five way pipe	SUS201	1	
10		Control box cover plate	SPCC15	1	
9	YW69041200900	Open flat round head blind rivet GB/T12618 4x12		4	
8	YW20030004000	Adjustable spring buckle SAL-6U-A-35*	Assembly	5	
7	YL22081000100	Transparent filter barrel SAL-810G-A-05(Ver.B)**	Transparent PC	1	
6	BM30055000050	Shini blower RB-550 (3.75kW)*	Assembly	1	
		Right column	Assembly	1	
		Base	SPCC3.0	1	
		Fuma wheel GD-40F black	Rubber	4	
		Standard spring washer GB/T93 6-Longzme		16	
		Cross socket head tapping screw M6x15		16	

52	Copper connector	H58	1	
51	Filter spray valve assembly	Assembly	1	5
50	Filter barrel fixed frame	SPCC3.0	1	4
49	Control bottom plate	SECC15	1	3
48	Control box	SPCC15	1	2
47	Integrated filter barrel	Assembly	1	1

序号	代号	名称	材质	数量	备注	序号	代号	名称	材质	数量	备注
		制图				标题	SAL-5HP-UG124	图号	SAL-5HP-UG124-ALL	比例	1:15
		设计					一对四分高式真空填料机			数量	1
		校对								材质	Assembly
		审核								表面要求	
标记	更改前	更改后	更改人	日期	审核	日期				物料号	



附：SVBV-50装配图与装配材料明细表(BY20005000300)

机型版本号: Ver.B

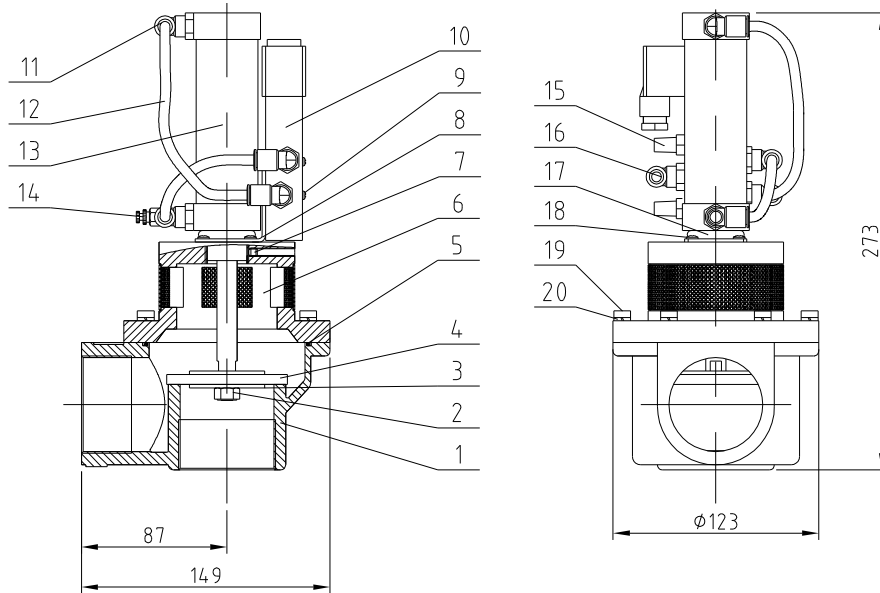

"x" indicates the items that may be damaged; "x x" indicates the items that are more likely to be damaged. It is recommended to back them up. Please confirm the version number of the instruction manual before placing an order to purchase spare parts, so as to ensure that the material number of spare parts is consistent with the physical one.

20	YW65006000100	Standard spring washer GB/T93 6-Longzine		6	
19	YW61062500000	Inner hexagon column screw GB/T170.1 M6x25-A2-70(SUS)		6	
18	YW63040600000	Cross recessed pan head screw M4x6		4	
17	YR20305000000	O-type seal ring $\phi 30 \times \phi 5$ *	Rubber	1	
16	YW80081800100	L thread connector APL8-01 1/8- $\phi 8$	Assembly	1	
15	YW80010800000	Copper muffler 1/8" (has mould)	Assembly	2	
14	YW80061800000	Adjustable air pipe connector ASL6-1/8	Assembly	1	
13	YE31326000100	Cylinder MBL32x60U(Air TAC) *	Assembly	1	
12	YR60000600400	PU air pipe $\phi 6$ black 200M/roll	PU	0.3m	
11	YW80061800200	L thread connector APL6-01 1/8- $\phi 6$	Assembly	3	
10	YE32421600100	Solenoid valve 4V210-06/AC24V *	Assembly	1	
9	YW63042500000	Cross recessed pan head screw GB/T-818 M4x25-Longzine		2	
8	BL20380500020	Solenoid valve fixed piece SPDV-38-ALL-05	SPCC2.0	1	
7	YW68005500000	Inner hex flat end lock screw GB/T177 M5x5-Longzine		1	
6	BW20500100010	Upper cover SVBV-50-ALL-01	Assembly	1	
5	YR20259800000	Rubber O-type seal ring seal ring 2.5x98 *	Rubber	1	
4	BR10651200040	4-way valve diaphragm 65x12x8mm plastic covered (has mould) *	Assembly	1	
3	BL90201870020	Washer SPDV-63-A-03(SUS201)		2	
2		Hex nut M10x125		1	Come with Cylinder
1	BW20001501210	Lower cover SPDV-50-ALL-02 white	ZL101	1	

序号	代号	名称	材质	数量	备注
----	----	----	----	----	----

					制图	版号	标题	图号	比例	1:4	数量	1
					设计	核准	SVBV-50 Vacuum breaking diaphragm valve	SVBV-50-ALL			材质	Assembly
					校对		信易电热机械股份有限公司 Shini Plastics Technologies, Inc.			表面要求		
标记	更改前	更改后	更改人	日期	审核	日期				物料号		

机器装配图与装配材料明细表SAL-5HP-UG124-D

机型版本号: Ver.F

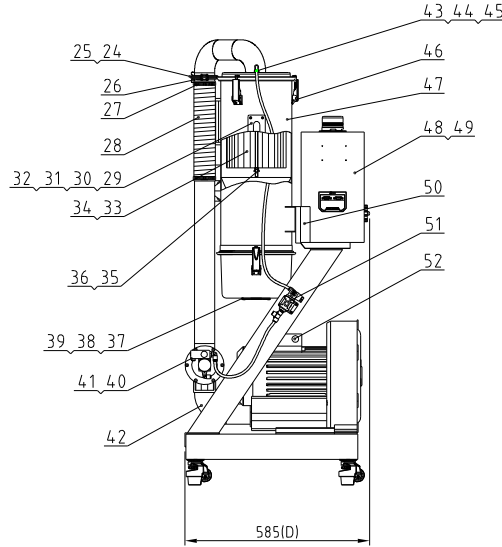
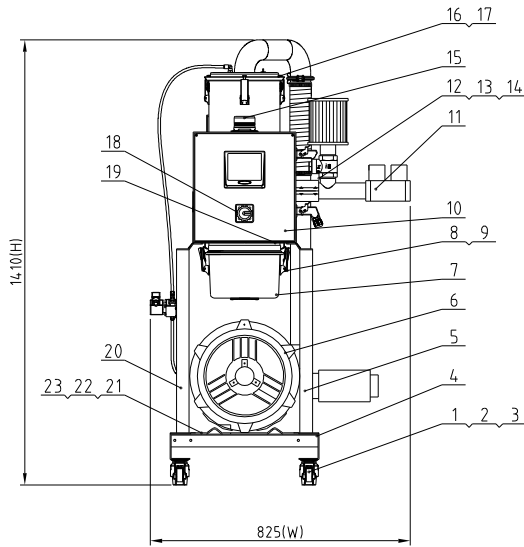

Tech. Req.

1. Main performance parameters:

- a. The output is 1200kg/hr (the data is obtained under the test standard of materials' bulk density in diameter of 0.65kg/L, plastic particle diameter 3-5m, vertical height of 4 m, and horizontal distance of 5m)
- b. Conveying pipe diameter: 1.5inch, suction air pipe diameter: 2inch.
- c. SAL-5HP-UG124-D host unit weight is 175KG
- d. SAL-5HP-UG124-D high pressure blower power is 3 (3φ) kW.
- e. Pneumatic working pressure 0.4-0.8MPa.

2. "\*" indicates the items that may be damaged; "\*\*" indicates the items that are more likely to be damaged.

It is recommended to back them up.

Please confirm the version number of the instruction manual before placing an order to purchase spare parts, so as to ensure that the material number of spare parts is consistent with the physical one.

46	YW69050100000	Open flat round head blind rivet GB/T12618 4x6		6	
45	YR60000800000	PU air pipe Φ8×Φ6 black 100M/roll		18m	
44	BH13033000810	Reverse cleaning pipe nozzle SAL-330-A-08	6061	1	
43	YW80083800200	L thread connector AP18-03 3/8-08	Assembly	1	
42		Air inlet pipe	SUS201	1	
41		Vacuum breaking diaphragm valve pipe	SUS201	1	
40	BY20005000300	Vacuum breaking diaphragm valve SVBV-50-2ZVDC*	Assembly	1	
39	YW62041200000	Large cross socket flat head screw M6x12-Longzine		4	
38	YR10243600000	Suction pipe round fastener SAL-24U/36U*	Rubber	1	
37		Transparent filter barrel fender	SUS201	1	
36	YW66082200100	Large washer C grade GB/T196 818.4x24x21-Longzine		1	
35	YW69051600000	Butterfly nut 5/16"	Q235	1	
34		Filter fixing plate	SECC2.0	1	
33	YR50181100000	Filter ADC3 rubber fastener (SHD-1000H-A-ALL-09)*	Assembly	1	
32	YW62051000100	Large cross socket flat head screw JIS1111 M5x10-Longzine		4	
31	BW09000030440	Arc 4-hole iron plate electroplate	Q235	1	
30	YR40000400000	Sight glass fastener four hole (SHD-12-A-54)*	Rubber	1	
29	YR40001200100	Acryl 4-hole (SHD-12-A-55)*	PC	1	
28	YR60002500000	Steel wire hose 2.5"(PUR355)*	PUR355	0.3m	
27	YW20007600000	Steel wire pipe 76mm		2	
26		Air suction pipe	Assembly	1	
25	YR20002500300	Stainless steel pressing clamp seal ring 2.5"	Silical gel	1	
24	YW07002501600	Stainless steel stamping clamp 2.5"	Assembly	1	
23	YW66103200000	Large washer A grade GB/T196 1010.5x30x251-Longzine		4	
22	YW64101100000	Hex nut M10 anti-loose (thickness 11mm)		4	
21	YW61102000000	Inner hexagon column screw GB/T701 M10x20-12.9-Longzine		4	
20		Left column	Assembly	1	
19	BL50135000020	Wire clamp fixed plate PG135 SG-S-011(has mould)	SPCC2.0	1	
18	YE10021160000	Main power switch T0-2-1EA/SVB/20A(EATON)	Assembly	1	
17	YR10080000300	Filter barrel fastener SAL-810G-A-03(Ver.A)Rubber(white)	Nitrile rubber	2	
16		Filter hopper cover assembly	Assembly	1	
15	BL90000011520	Three color alarm light (red, yel, green, buzzer)*	Assembly	1	
14	YR50128200000	Suction box filter SP-F ext 128x28x148*	Assembly	1	
13	YW59150000000	Check valve 15"(copper)	Assembly	1	
12	BW20002002050	Aluminum pipe coupler 2"	Assembly	1	
11		Five way pipe	SUS201	1	
10		Control box cover plate	SPCC15	1	
9	YW69041200900	Open flat round head blind rivet GB/T12618 4x12		4	
8	YW20030004000	Adjustable spring buckle SAL-6U-A-35*	Assembly	5	
7	YL22081000100	Transparent filter barrel SAL-810G-A-05(Ver.B)*	Transparent PC	1	
6	YM30252000100	Ruinj blower ZHBS20H46 (3kW)*	Assembly	1	
5		Right column	Assembly	1	
4		Base	SPCC3.0	1	
3	YW03004000100	Fuma wheel GD-40F black	Rubber	4	
2	YW65006000100	Standard spring washer GB/T193 6-Longzine		16	
1	YW67061500600	Cross socket head tapping screw M6x15		16	

52		Copper connector	H58	1	
51		Filter spray valve assembly	Assembly	1	
50		Filter barrel fixed frame	SPCC3.0	1	
49		Control bottom plate	SECC15	1	
48		Control box	SPCC15	1	
47		Integrated filter barrel	Assembly	1	

序号	代号	名称	材质	数量	备注	序号	代号	名称	材质	数量	备注
		制图				标题	SAL-5HP-UG124-D	图号	SAL-5HP-UG124-D-ALL	比例	1:15
		设计					一对四分高真空填充机			数量	1
		校对								材质	Assembly
		审核								表面要求	
标记	更改前	更改后	更改人	日期	审核	日期	SHINI 信易电热机械股份有限公司 Shini Plastics Technologies, Inc.		物料号		

附：SVBV-50装配图与装配材料明细表(BY20005000300)

机型版本号: Ver.B

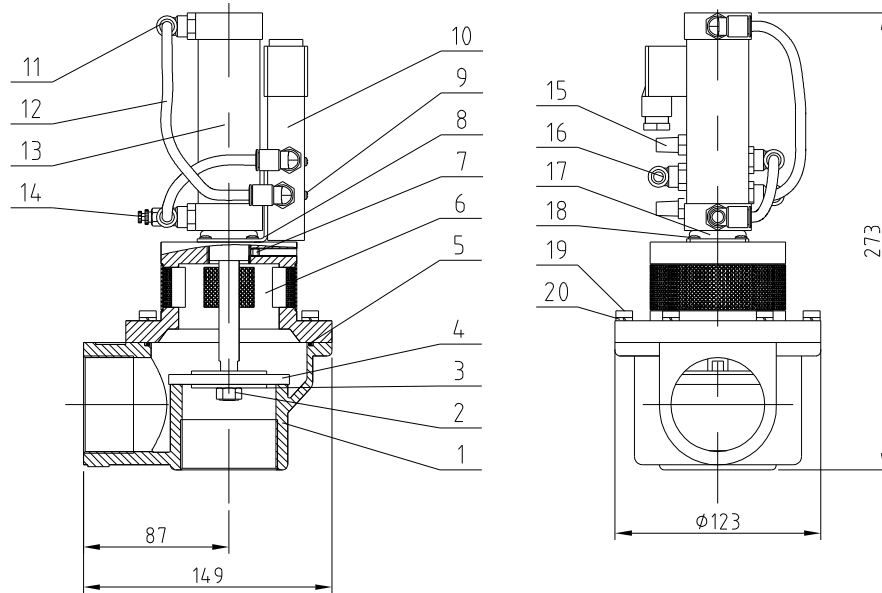

\*Indicates the items that may be damaged. "\*\*" indicates the items that are more likely to be damaged. It is recommended to back them up. Please confirm the version number of the instruction manual before placing an order to purchase spare parts, so as to ensure that the material number of spare parts is consistent with the physical one.

20	YW65006000100	Standard spring washer GB/T93 6-Longzine		6	
19	YW61062500000	Inner hexagon column screw GB/T170.1 M6x25-A2-70(SUS)		6	
18	YW63040600000	Cross recessed pan head screw M4x6		4	
17	YR20305000000	O-type seal ring $\phi 30 \times \phi 5$ *	Rubber	1	
16	YW80081800100	L thread connector APL8-01 1/8- $\phi 8$	Assembly	1	
15	YW80010800000	Copper muffler 1/8" (has mould)	Assembly	2	
14	YW80061800000	Adjustable air pipe connector ASL6-1/8	Assembly	1	
13	YE31326000100	Cylinder MBL32x60U(Air TAC) *	Assembly	1	
12	YR60000600400	PU air pipe $\phi 6$ black 200M/roll	PU	0.3m	
11	YW80061800200	L thread connector APL6-01 1/8- $\phi 6$	Assembly	3	
10	YE32421600100	Solenoid valve 4V210-06/AC24V *	Assembly	1	
9	YW63042500000	Cross recessed pan head screw GB/T-818 M4x25-Longzine		2	
8	BL20380500020	Solenoid valve fixed piece SPDV-38-ALL-05	SPCC2.0	1	
7	YW68005500000	Inner hex flat end lock screw GB/T177 M5x5-Longzine		1	
6	BW20500100010	Upper cover SVBV-50-ALL-01	Assembly	1	
5	YR20259800000	Rubber O-type seal ring seal ring 2.5x98 *	Rubber	1	
4	BR10651200040	4-way valve diaphragm 65x12x8mm plastic covered (has mould) *	Assembly	1	
3	BL90201870020	Washer SPDV-63-A-03(SUS201)		2	
2		Hex nut M10x125		1	Come with Cylinder
1	BW20001501210	Lower cover SPDV-50-ALL-02 white	ZL101	1	

序号	代号	名称	材质	数量	备注
	SVBV-50	Vacuum breaking diaphragm valve		1	
		图号	SVBV-50-ALL	比例	1:4
				数量	1
				材质	Assembly
				表面要求	
				物料号	



					制图	版号			
					设计	核准			
					校对				
标记	更改前	更改后	更改人	日期	审核	日期			



机器装配图与装配材料明细表SAL-10HP-UG124

机型版本号: Ver.F

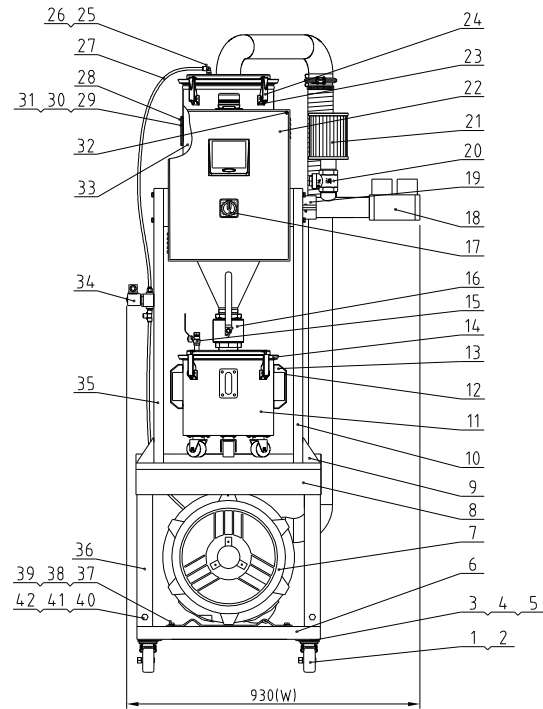
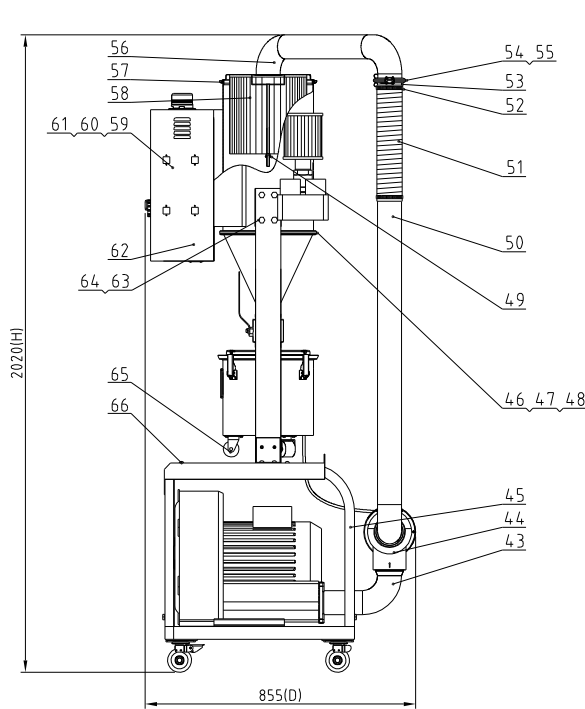

Tech Req

1 Main performance parameters:

a The output is 1800kg/hr (the data is obtained under the test standard of materials' bulk density in diameter of 0.65kg/L, plastic particle diameter 3-5m, vertical height of 4 m, and horizontal distance of 5m).

b Conveying pipe diameter 2inch, suction air pipe diameter 2.5inch.

c SAL-10HP-UG124 host unit weight is 185KG.

d SAL-10HP-UG124 high pressure blower power is 7.5 (3φ) kW.

e Pneumatic working pressure 0.4-0.8MPa.

2: "\*"Indicates the items that may be damaged, "\*\*" indicates the items that are more likely to be damaged.

It is recommended to back them up.

Please confirm the version number of the instruction manual before placing an order to purchase spare parts, so as to ensure that the material number of spare parts is consistent with the physical one

66	YW62061000000	Large cross socket flat head screw JIS1111 M6x10-Longzine		14
65	YW03000200000	Black castor 2"	Assembly	3
64	YW64080600000	Hexagonal nut GB/T6170 M8 Longzine		8
63	YW60085000000	Hexagon bolt GB/T5783 M8x50-8-Longzine		8
62	BL50135000020	Wire clamp fixed plate PG135 SG-S-0(Has mould)	SPCC2.0	1
61		Control bottom plate	SECC15	1
60		Control box cover plate	SPCC15	1
59		Control box	SPCC15	1
58	YR50024400000	Filter ext 24L*inner 14.9H250*	Assembly	1
57	YR10028700000	Filter barrel fastener *	Rubber	2
56		Filter hopper cover assembly	Assembly	1
55	YR20000300000	Stainless steel pressing clamp seal ring 3"		1
54	YW07000300300	Stainless steel stamping clamp 3"	SUS304	1
53		Air suction pipe	Assembly	1
52	YW02008900000	Steel wire pipe 89mm		2
51	YR60000300000	Steel wire hose 3"(PUR355)*	PUR355	0.4M
50		Vacuum breaking diaphragm valve connection pipe	SUS201	1
49	YW69051600000	Butterfly nut 5/16"	Q235	1
48	YR10241300100	Enlarged hopper fastenerSHR-24U-A-13 *	White stirral gel	1

47		Bundle ring combination	Assembly	1	
46		Filter hopper (lower)	Assembly	1	
45		Bracket 1 Assembly	SPCC2.0	1	
44	BY20007600450	Vacuum breaking diaphragm valve SVBV-76 24VD*	Assembly	1	
43		Air inlet pipe	SUS201	1	
42	YW65008000100	Standard spring washer GB/T93 8-Longzine		12	
41	YW66081600000	Flat washer A grade GB/T93 18 4x16-1.6L-Longzine		20	
40	YW60081600100	Hexagon bolt GB/T5781 M8x16-4-8-Longzine		4	
39	YW66103200000	Large washer A grade GB/T196 10(10.5x30x2.5)-Longzine		4	
38	YW64101100000	Hex nut M10 anti-loose (thickness 11mm)		4	
37	YW61105000000	Inner hexagon column screw GB/T7017 M10x50-12.9-Longzine		4	
36		Bracket 2 Assembly	SPCC2.0	1	
35		Filter tank Left column	SPCC3.0	1	
34		Filter spray valve assembly	Assembly	1	
33		Filter tank (upper)	Assembly	1	
32	YW67050800000	Cross socket pan head self-tapping lock screw GB6560 M5-8 Longzine		2	
31	BW09000030440	Acrylic four-hole iron sheet	Q235A	2	
30	YR40001200100	Acrylic four-hole material PC*	PC	2	
29	YR40000400000	Sight glass fastener four hole *	Rubber	2	
28	YW62051000100	Large cross socket flat head screw JIS1111 M5x10		8	
27	YR60000800000	PU air pipe Ø8*Ø6 black 100M/roll *		2.3M	
26	BH13033000810	Reverse cleaning pipe nozzle SAL-330-A-08	6061	1	
25	YW80081200000	L thread connector APL8-04 1/2-Ø8	Assembly	8	
24	YW02003000400	Adjustable spring buckle SAL-6U-A-35*	Assembly	8	
23	YW690501000009	Open flat round head blind rivet GB/T 12618 4x6		16	
22	BL90000011520	Three color alarm light (red, yellow, green, buzzer)	Assembly	1	
21	YR50128200000	Suction box filter SP-F ext. 128x28x148*	Assembly	1	
20	YW59150000000	Check valve 15" (copper)	Assembly	1	
19	BW20002500050	Aluminum pipe coupler 2.5"	Assembly	1	
18		Five-way pipe	SUS201	1	
17	YE10323200000	Main power switch P1-32/EA/SVB 32A	Assembly	1	
16	YW50020000000	Copper ball valve 2"	Assembly	1	
15	YW50041000000	Copper ball valve 1/4"-PT	Assembly	1	
14		Dust collection bin cover	Assembly	1	
13	YW61061601200	Inner hexagon column screw GB/T7017 M6x16-12.9-Longzine		4	
12	BW20012000040	Aluminum square handle L120	YL112	2	
11		Dust collection bin welding parts	SPCC15	1	
10		Filter tank Right column	SPCC3.0	1	
9		Column support	SPCC2.0	2	
8		Middle plate	SPCC2.0	1	
7	YM30281000100	Ruijing blower 2HB810H26(7.5KW)*	Assembly	1	
6		Base	SPCC3.0	1	
5	YW64012100000	Standard spring washer GB/T93 6-Longzine		16	
4	YW66061800000	Large washer A grade GB/T196 16-Longzine		16	
3	YW60061500100	Hexagon bolt GB/T5783 M6x16-12.9-Longzine		16	
2	YW03000300200	Free type universal casters 3"	Assembly	2	
1	YW03000300000	Brake type universal caster 3"	Assembly	2	

制图	版号	标题	图号	比例	1:15	数量	1
设计	核准	SAL-10HP-UG124	SAL-10HP-UG124-ALL	材质	Asseblly		
校对	日期	一对四分离式真空填料机		表面要求			
标记	更改前	更改后	更改人	日期	审核	日期	物料号



附: SVBV-76 装配图与装配材料明细表(BY20007600450)

机型版本号: Ver.B

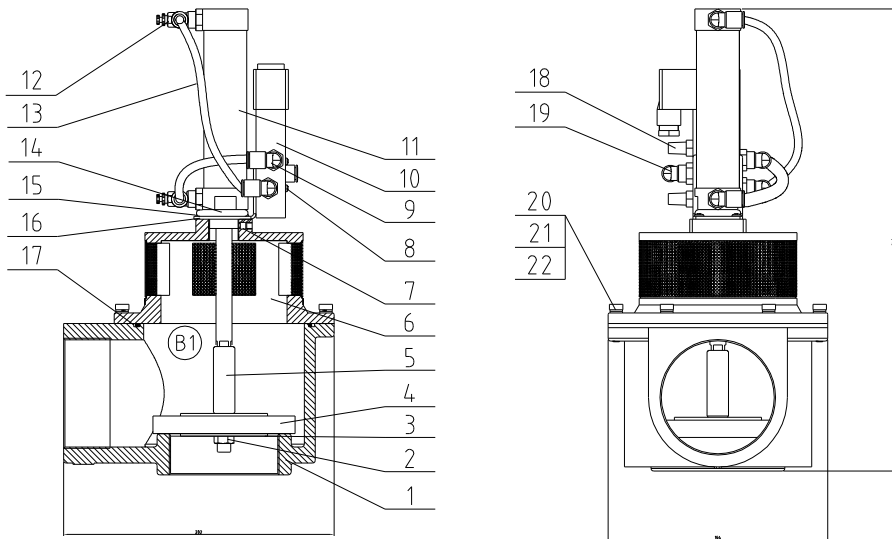

\*Indicates the items that may be damaged; "\*\*" indicates the items that are more likely to be damaged. It is recommended to back them up. Please confirm the version number of the instruction manual before placing an order to purchase spare parts, so as to ensure that the material number of spare parts is consistent with the physical one.

22	YW65006000100	Flat washer A grade GB/T97.16-Longzine		6	
21	YW65006000100	Standard spring washer GB/T93 6-Longzine		6	
20	YW61062501200	Inner hexagon column screw GB/T70.1 M6x25-12.9-Longzine For automation		6	
19	YW80081800100	L thread connector APL8-01 1/8-Ø8(Air TAC)	Assembly	1	
18	YW80010800000	Copper muffler 1/8"	Assembly	2	
17	YR20013030000	O-type seal ring Outer diameter 130 wire diameter 3*	Fluorine Rubber	1	
16	BL20380500020	Solenoid valve fixed piece	SPCC2.0	1	
15	YW63040600000	Cross recessed pan head screw GB/T-818 M4x6-Longzine		4	
14	YR20305000000	O-type seal ring Ø30×Ø5 *	Rubber	1	
13	YR60000600400	PU air pipe Ø6 black 200M/roll	PU	0.5M	
12	YW80061800000	Adjustable air pipe connector ASL6-1/8	Assembly	2	
11	YE31258000000	Cylinder MAL25×80-U(AIRTAC) *	Assembly	1	
10	YE32421600100	Solenoid valve 4V210-06/AC24V *	Assembly	1	
9	YW80061800200	L thread connector APL6-01 1/8-Ø6(Air TAC)	Assembly	2	
8	YW63042500000	Cross recessed pan head screw GB/T-818 M4x25-Longzine		2	
7	YW68005500000	Inner hex flat end lock screw GB/T77 M5x5-Longzine		1	
6	BA90760200010	Upper cover	Assembly	1	
5	BH10007600310	Diaphragm fixing screw	Q235	1	
4	BL90007600040	Diaphragm *	Assembly	1	
3		Diaphragm washer	SUS201	2	
2	YW64101100000	Hex. nut M10 anti-loose (thickness 11mm)		1	
1	BA90760100010	Lower cover	AC4B	1	

序号	代号	名称	材质	数量	备注
----	----	----	----	----	----

					制图	版本号	标题	图号	比例	1:5	数量	1
					设计	核准	SVBV-76	SVBV-76-ALL			材质	Assembly
					校对		Vacuum breaking diaphragm valve			表面要求		
标记	更改前	更改后	更改人	日期	审核	日期	信易電熱機械股份有限公司 Shini Plastics Technologies, Inc.				物料号	

机器装配图与装配材料明细表SAL-10HP-UG124-D

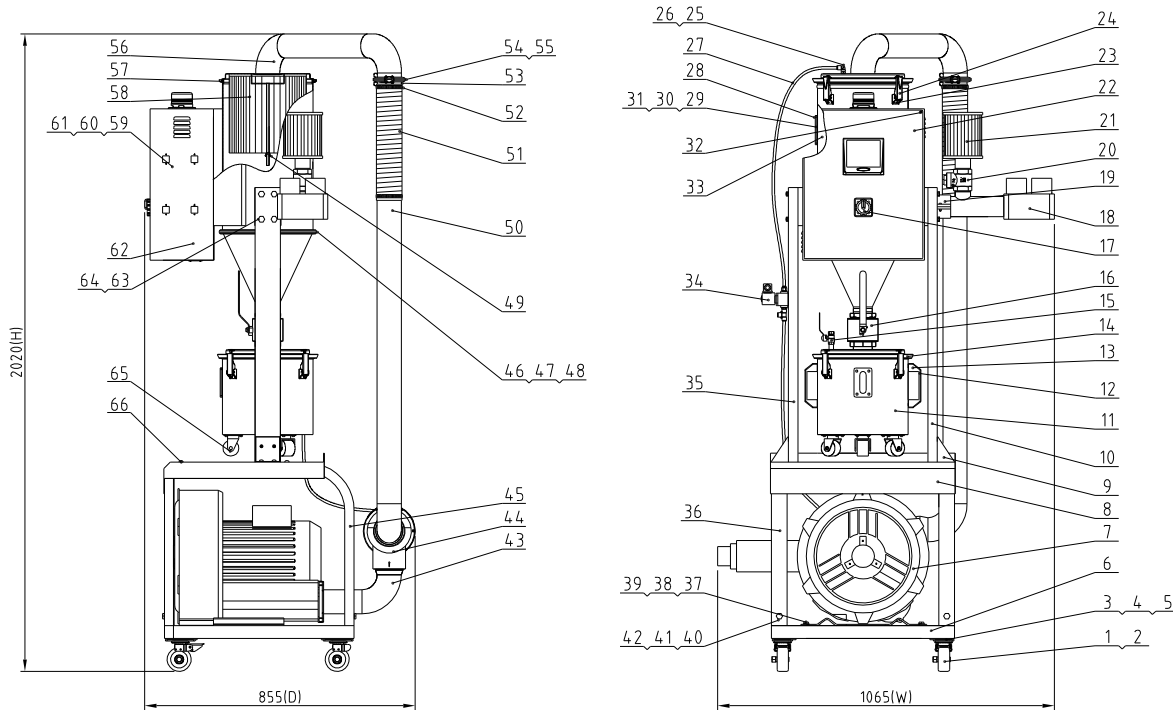

				机型版本号: Ver.F	
4.7		Bundle ring combination	Assembly	1	
4.6		Filter hopper (lower)	Assembly	1	
4.5		Bracket 1 Assembly	SPCC2.0	1	
4.4	BY20007600450	Vacuum breaking diaphragm valve SV8V-76 24VDC*	Assembly	1	
4.3		Air inlet pipe	SUS201	1	
4.2	YW65008000100	Standard spring washer GB/T193 8-Longzine		12	
4.1	YW66081600000	Flat washer A grade GB/T197 18 4x16-1.6L-Longzine		20	
4.0	YW60081600100	Hexagon bolt GB/T5783 M8x16-4 8-Longzine		4	
3.9	YW66103200000	Large washer A grade GB/T196 10/10 5x20x2.5L-Longzine		4	
3.8	YW64101100000	Hex nut M10 anti-loose (thickness 11mm)		4	
3.7	YW61105000000	Inner hexagon column screw GB/T1701 M10x50-12.9-Longzine		4	
3.6		Bracket 2 Assembly	SPCC2.0	1	
3.5		Filter tank Left column	SPCC3.0	1	
3.4		Filter spray valve assembly	Assembly	1	
3.3		Filter tank (upper)	Assembly	1	
3.2	YW67050800000	Cross socket pan head self-tapping lock screw GB6560 M5x8 Longzine		2	
3.1	BW09000304.4	Acrylic four-hole iron sheet	Q235A	2	
3.0	YR4.0001200100	Acrylic four-hole material PC	PC	2	
2.9	YR4.00004.00000	Sight glass fastener four hole *	Rubber	2	
2.8	YW62051000100	Large cross socket flat head screw JIS1111 M5x10		8	
2.7	YR60000800000	PU air pipe Ø8*Ø6 black 100M/roll *		2.3M	
2.6	BH13033000810	Reverse cleaning pipe nozzle SAL-330-A-08	6061	1	
2.5	YW80081200000	L thread connector APL8-04 1/2-Ø8	Assembly	8	
2.4	YW020030004.00	Adjustable spring buckle SAL-60-A-35*	Assembly	8	
2.3	YW690501000009	Open flat round head blind rivet GB/T 12618 4x6		16	
2.2	BL90000011520	Three color alarm light (red, yellow, green, buzzer)	Assembly	1	
2.1	YR50128200000	Suction box filter SP-F ext. 128*28*148*	Assembly	1	
2.0	YW59150000000	Check valve 1.5" (copper)	Assembly	1	
1.9	BW20002500050	Aluminum pipe coupler 2.5"	Assembly	1	
1.8		Five way pipe	SUS	1	
1.7	YE10323200000	Main power switch P1-32/EA/SVB 32A	Assembly	1	
1.6	YW50020000000	Copper ball valve 2"	Assembly	1	
1.5	YW50041000000	Copper ball valve 1/4"-PT	Assembly	1	
1.4		Dust collection bin cover	Assembly	1	
1.3	YW61061601200	Inner hexagon column screw GB/T1701 M6x16-12.9-Longzine		4	
1.2	BW20012000040	Aluminum square handle L120	YL112	2	
1.1		Dust collection bin welding parts	SPCC1.5	1	
1.0		Filter tank Right column	SPCC3.0	1	
9		Column support	SPCC2.0	2	
8		Middle plate	SPCC2.0	1	
7	YM30272000100	Roujing blower EHS2HB720H56(7.5KW)*	Assembly	1	
6		Base	SPCC3.0	1	
5	YW64012100000	Standard spring washer GB/T193 6-Longzine		16	
4	YW66061800000	Large washer A grade GB/T196 16-Longzine		16	
3	YW60061500100	Hexagon bolt GB/T5783 M6x16-12.9-Longzine		16	
2	YW03000300200	Free type universal casters 3"	Assembly	2	
1	YW03000300000	Brake type universal caster 3"	Assembly	2	

66	YW62061000000	Large cross socket flat head screw JIS1111 M6x10-Longzine		14	
65	YW03000200000	Black castor 2"	Assembly	3	
64	YW64080600000	Hexagonal nut GB/T6170 M8 Longzine		8	
63	YW60085000000	Hexagon bolt GB/T5783 M8x50-8 8-Longzine		8	
62	BL50135000020	Wire clamp fixed plate PG135 SG-S-01(has mould)	SPCC2.0	1	
61		Control bottom plate	SECC1.5	1	
60		Control box cover plate	SPCC1.5	1	
59		Control box	SPCC1.5	1	
58	YR50024.00000	Filter ext 244*inner 149*H250*	Assembly	1	
57	YR10028700000	Filter barrel fastener *	Rubber	2	
56		Filter hopper cover assembly	Assembly	1	
55	YR20000300000	Stainless steel pressing clamp seal ring 3"		1	
54	YW07000300300	Stainless steel stamping clamp 3"	SUS304	1	
53		Air suction pipe	Assembly	1	
52	YW02008900000	Steel wire pipe Ø9mm		2	
51	YR60000300000	Steel wire hose 3" (PUR355)*	PUR355	0.4 M	
50		Vacuum breaking diaphragm valve connection pipe	SUS201	1	
4.9	YW69051600000	Butterfly nut 5/16"	Q235	1	
4.8	YR10241300100	Enlarged hopper fastener SHR-24U-A-13 *	white silicon gel	1	

Tech Req:

1 Main performance parameters

a The output is 2000kg/hr (the data is obtained under the test standard of materials' bulk density in diameter of 0.65kg/L, plastic particle diameter 3-5m, vertical height of 4 m, and horizontal distance of 5m)

b Conveying pipe diameter: 2inch, suction air pipe diameter: 2.5inch

c SAL-10HP-UG124-D host unit weight is 192KG

d SAL-10HP-UG124-D high pressure blower power is 7.5 (3φ) kW

e Pneumatic working pressure 0.4-0.8MPa

2 "\*" indicates the items that may be damaged, "\*\*" indicates the items that are more likely to be damaged

It is recommended to back them up.

Please confirm the version number of the instruction manual before placing an order to purchase spare parts, so as to ensure that the material number of spare parts is consistent with the physical one.

标记	更改前	更改后	更改人	日期	制图	版号	标题	图号	比例	数量	备注
					设计	核	标题 SAL-10HP-UG124-D	图号 SAL-10HP-UG124-D-ALL	1:15	1	
					校对	准	一对四分高真空填充机		1:15	1	材质 Assembly
					审核	日期	SHINI 信易电热机械股份有限公司 Shini Plastics Technologies, Inc.		表面要求		
									物料号		

附: SVBV-76 装配图与装配材料明细表(BY20007600450)

机型版本号: Ver.B

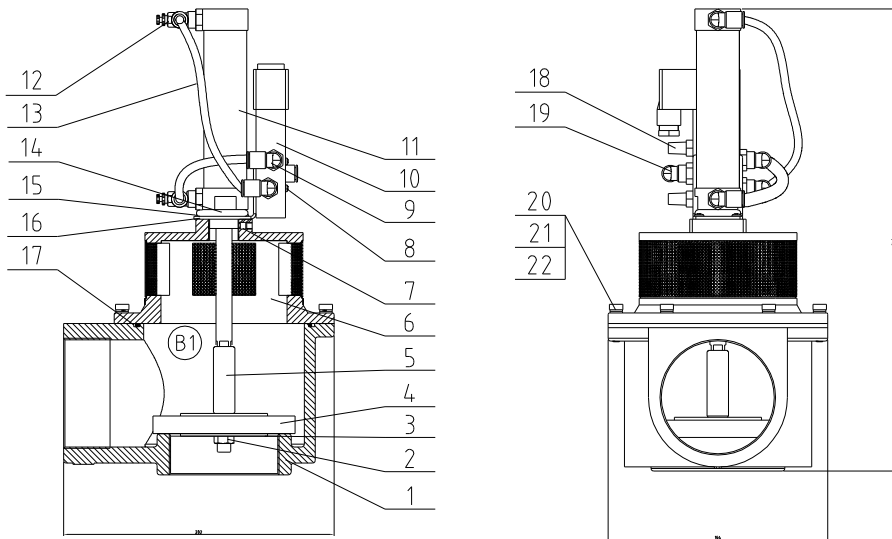

\*Indicates the items that may be damaged; "\*\*" indicates the items that are more likely to be damaged. It is recommended to back them up. Please confirm the version number of the instruction manual before placing an order to purchase spare parts, so as to ensure that the material number of spare parts is consistent with the physical one.

22	YW65006000100	Flat washer A grade GB/T97.16-Longzine		6	
21	YW65006000100	Standard spring washer GB/T93 6-Longzine		6	
20	YW61062501200	Inner hexagon column screw GB/T70.1 M6x25-12.9-Longzine For automation		6	
19	YW80081800100	L thread connector APL8-01 1/8-Ø8(Air TAC)	Assembly	1	
18	YW80010800000	Copper muffler 1/8"	Assembly	2	
17	YR20013030000	O-type seal ring Outer diameter 130 wire diameter 3*	Fluorine Rubber	1	
16	BL20380500020	Solenoid valve fixed piece	SPCC2.0	1	
15	YW63040600000	Cross recessed pan head screw GB/T-818 M4x6-Longzine		4	
14	YR20305000000	O-type seal ring Ø30xØ5 *	Rubber	1	
13	YR60000600400	PU air pipe Ø6 black 200M/roll	PU	0.5M	
12	YW80061800000	Adjustable air pipe connector ASL6-1/8	Assembly	2	
11	YE31258000000	Cylinder MAL25x80-U(AIRTAC) *	Assembly	1	
10	YE32421600100	Solenoid valve 4V210-06/AC24V *	Assembly	1	
9	YW80061800200	L thread connector APL6-01 1/8-Ø6(Air TAC)	Assembly	2	
8	YW63042500000	Cross recessed pan head screw GB/T-818 M4x25-Longzine		2	
7	YW68005500000	Inner hex flat end lock screw GB/T77 M5x5-Longzine		1	
6	BA90760200010	Upper cover	Assembly	1	
5	BH10007600310	Diaphragm fixing screw	Q235	1	
4	BL90007600040	Diaphragm *	Assembly	1	
3		Diaphragm washer	SUS201	2	
2	YW64101100000	Hex. nut M10 anti-loose (thickness 11mm)		1	
1	BA90760100010	Lower cover	AC4B	1	

序号	代号	名称	材质	数量	备注
		标题	比例	1:5	数量 1
		图号	材质	Assembly	
		表面要求			
		物料号			

制图	版号	标题	SVBV-76	图号	SVBV-76-ALL
设计	核准	Vacuum breaking diaphragm valve			
校对	核准	信易電熱機械股份有限公司 Shini Plastics Technologies, Inc.			
标记	日期				
更改前	更改后	更改人	日期	审核	日期

机器装配图与装配材料明细表SAL-20HP-UG124-D

机型版本号: Ver.C

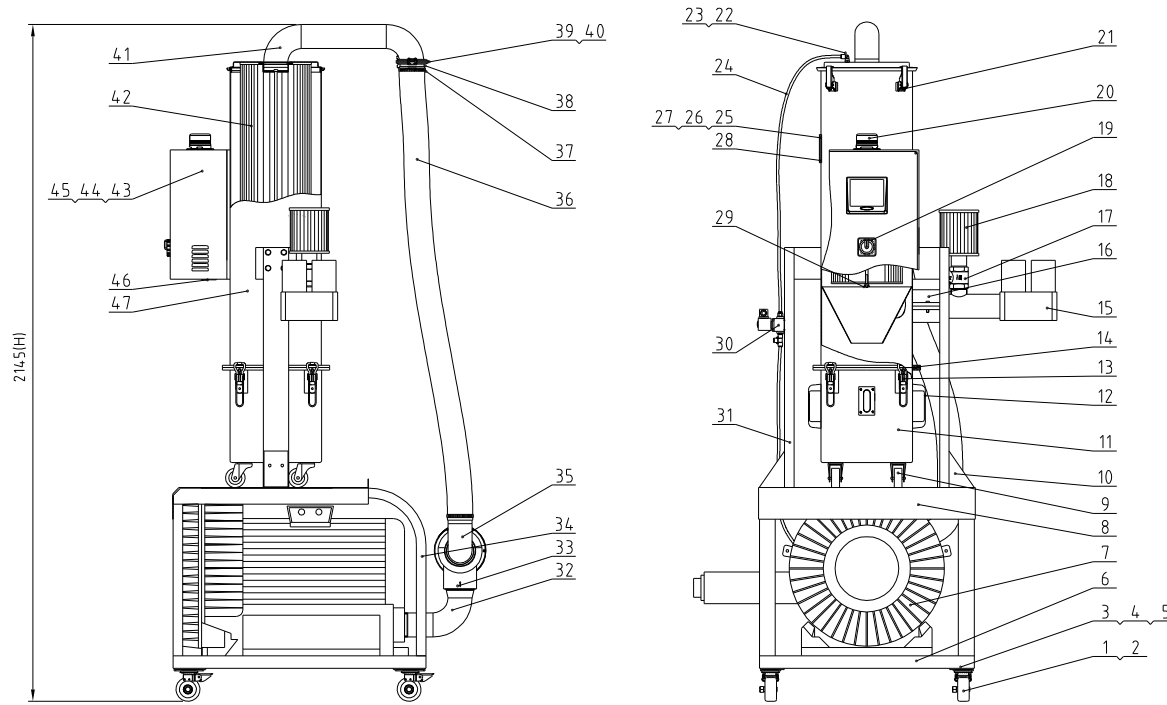

Tech. Req:  
 1 Main performance parameters:  
 a. The output is 2200kg/hr (the data is obtained under the test standard of materials' bulk density in diameter of 0.65kg/L, plastic particle diameter 3-5mm, vertical height of 4 m, and horizontal distance of 5m)  
 b. Conveying pipe diameter: 2.5inch, suction air pipe diameter: 3inch  
 c. SAL-20HP-UG124-D host unit weight is 246KG.  
 d. SAL-20HP-UG124-D high pressure blower power is 11.3(kw).  
 e. Pneumatic working pressure: 0.4-0.8MPa.  
 2. "\*" Indicates the items that may be damaged; "\*" indicates the items that are more likely to be damaged. It is recommended to back them up.  
 Please confirm the version number of the instruction manual before placing an order to purchase spare parts, so as to ensure that the material number of spare parts is consistent with the physical one.

47	Integrated filter barrel	Assembly	1	
46	BL45000502120 Wire clamp fixed plate M25 SG-S-01	SPCC2.0	1	
45	Base plate of control box	SECC1.5	1	
44	Control box cover plate	SPCC1.5	1	
43	Control box	SPCC1.5	1	
42	YR50226000000 Filter φ225×φ145×600*	SPCC1.5	1	
41	Filter hopper cover assembly	Assembly	1	
40	YR20000300000 Stainless steel pressing clamp seal ring 3"*		1	
39	YW07000300300 Stainless steel stamping clamp 3"	SUS304	1	
38	Air suction pipe	Assembly		
37	YW02003500000 Stainless steel pipe clamp 3.5"		2	
36	YR60303000000 Steel wire hose 3"*		1	1.6m
35	Vacuum braking diaphragm valve connection pipe	SUS201	1	
34	Welding diagram of bracket	SPCC2.0		Two pieces in total
33	BY20007600450 Vacuum braking diaphragm valve SVBV-76*	Assembly	1	
32	Air inlet pipe	SUS201	1	
31	Filter tank standing pole	SPCC2.0	2	
30	Filter spray valve assembly	Assembly	1	
29	YW69000800000 Butterfly nut 5/16"	Q235A	1	
28	YW62051000100 Large cross socket flat head screw JIS1111 M5×10-Longzine		8	
27	BW09000030440 Acrylic four-hole iron sheet	Q235A	2	
26	YR40001200100 Acrylic four-hole material PC*	PC	2	
25	YR40000400000 Sight glass fastener four hole *	Rubber	2	
24	YR60000800000 PU air pipe φ8×φ6 black *			2.5M
23	BH13033000810 Reverse cleaning pipe nozzle SAL-330-A-08	6061	1	
22	YW80081200000 L thread connector APLB-04 1/2-φ8	Assembly	8	
21	YW02003000400 Adjustable spring buckle SAL-6U-A-35	Assembly	4	
20	BL90000011520 Three color alarm light (red, yellow, green) buzzer	Assembly	1	
19	YE10210300000 Main power switch	Assembly	1	
18	YR50128200000 Suction box filter ext. 128×inner28×16*	Assembly	1	
17	YW59150000000 Check valve 15" (copper)	Assembly	1	
16	BH80003010050 Stainless steel pipe coupler SPC-3"	Assembly	1	
15	Five way pipe	SUS201	1	
14	YE32051800100 Dust collective hopper fastener *	Silical gel	1	
13	YW00121000400 Large handle (for SAL-20HP-UG-D)	Assembly	4	
12	BW20012000040 Aluminum square handle L120	YL112	2	
11	Dust collective hopper	SPCC1.5	1	
10	Column support	SPCC2.0	2	
9	YW03000200000 Black castor 2"	Assembly	3	
8	Middle plate	SPCC2.0	1	
7	YM30211000100 Ruijing blower 2#B820H36 11kW*	Assembly	1	
6	Base	SPCC3.0	1	
5	YW65006000100 Standard spring washer GB/T93 6-Longzine		16	
4	YW66061300000 Flat washer A grade GB/T97.1 6-Longzine		16	
3	YW60061500100 Hexagon bolt GB/T5783 M6×16-12.9-Longzine		16	
2	YW03000300200 Free type universal casters 3"	Assembly	2	
1	YW03000300000 Brake type universal caster 3"	Assembly	2	

48	YW82000100000	Release valve RV-02	Assembly	1	
序号	代号	名称	材质	数量	备注

制图	版号	图号	比例	1:15	数量	1
设计	核准	SAL-20HP-UG124-D	材质	Assembly		
校对		欧化分离式真空填料机				
标记	更改前	更改后	更改人	日期	审核	日期
SHINI			信易电热机械股份有限公司 Shini Plastics Technologies, Inc.			
表面要求			物料号			

附: SVBV-76 装配图与装配材料明细表(BY20007600450)

机型版本号: Ver.B

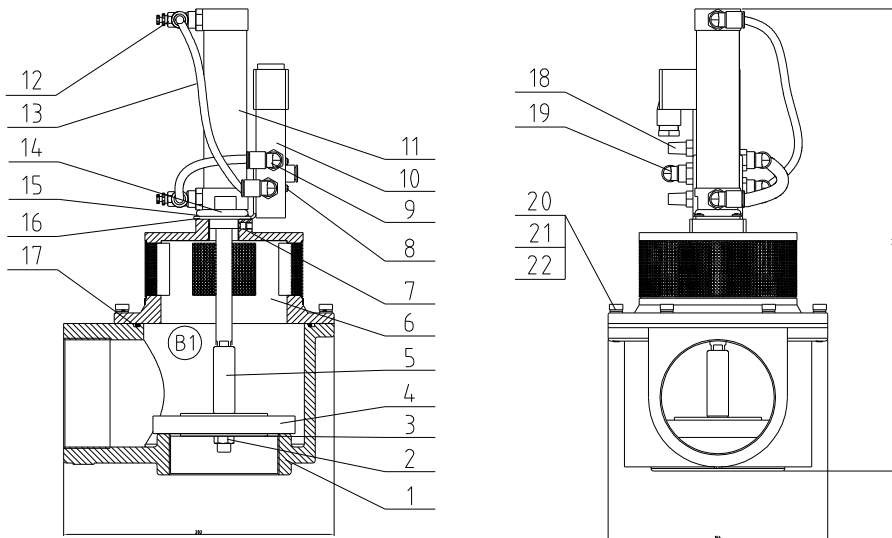

\*Indicates the items that may be damaged; "\*\*" indicates the items that are more likely to be damaged. It is recommended to back them up. Please confirm the version number of the instruction manual before placing an order to purchase spare parts, so as to ensure that the material number of spare parts is consistent with the physical one.

22	YW65006000100	Flat washer A grade GB/T97.16-Longzine		6	
21	YW65006000100	Standard spring washer GB/T93 6-Longzine		6	
20	YW61062501200	Inner hexagon column screw GB/T70.1 M6x25-12.9-Longzine For automation		6	
19	YW80081800100	L thread connector APL8-01 1/8-Ø8(Air TAC)	Assembly	1	
18	YW80010800000	Copper muffler 1/8"	Assembly	2	
17	YR20013030000	O-type seal ring Outer diameter 130 wire diameter 3*	Fluorine Rubber	1	
16	BL20380500020	Solenoid valve fixed piece	SPCC2.0	1	
15	YW63040600000	Cross recessed pan head screw GB/T-818 M4x6-Longzine		4	
14	YR20305000000	O-type seal ring Ø30×Ø5 *	Rubber	1	
13	YR60000600400	PU air pipe Ø6 black 200M/roll	PU	0.5M	
12	YW80061800000	Adjustable air pipe connector ASL6-1/8	Assembly	2	
11	YE31258000000	Cylinder MAL25×80-U(AIRTAC) *	Assembly	1	
10	YE32421600100	Solenoid valve 4V210-06/AC24V *	Assembly	1	
9	YW80061800200	L thread connector APL6-01 1/8-Ø6(Air TAC)	Assembly	2	
8	YW63042500000	Cross recessed pan head screw GB/T-818 M4x25-Longzine		2	
7	YW68005500000	Inner hex flat end lock screw GB/T77 M5x5-Longzine		1	
6	BA90760200010	Upper cover	Assembly	1	
5	BH10007600310	Diaphragm fixing screw	Q235	1	
4	BL90007600040	Diaphragm *	Assembly	1	
3		Diaphragm washer	SUS201	2	
2	YW64101100000	Hex. nut M10 anti-loose (thickness 11mm)		1	
1	BA90760100010	Lower cover	AC4B	1	
序号	代 号	名 称	材 质	数 量	备 注

					制图	版号	标题	图号	比例	1:5	数量	1
					设计	核 准	SVBV-76	SVBV-76-ALL			材质	Assembly
					校对		Vacuum breaking diaphragm valve			表面要求		
标记	更改前	更改后	更改人	日期	审核	日期	信易電熱機械股份有限公司 Shini Plastics Technologies, Inc.				物料号	