

| 符号/SYMBOL<br>型号/MODE | ⓐ    | ⓑ   | ⓒ  | ⓓ    | ⓔ   | ⓕ  | ⓖ    | ⓗ   | ⓘ   | ⓙ  |
|----------------------|------|-----|----|------|-----|----|------|-----|-----|----|
| STM-607              | 10.0 | 2.5 | 16 | 0.55 | 1.0 | 6  | 9    | 1.5 | 2.5 | 20 |
| STM-910              | 15.3 | 4.0 | 25 | 0.75 | 1.8 | 9  | 13.5 | 1.5 | 2.5 | 25 |
| STM-1220             | 21.2 | 6.0 | 32 | 1.5  | 3.4 | 12 | 18   | 1.5 | 4.0 | 32 |

|    |     |     |     |    |    |    |          |      |                     |    |                              |      |          |
|----|-----|-----|-----|----|----|----|----------|------|---------------------|----|------------------------------|------|----------|
|    |     |     |     |    | 制图 | 版号 | D        | 标题   | STM-607/910/1220-EB | 图号 | STM-607/910/1220-EB-400V-D-1 | 比例   | 第 1 张    |
|    |     |     |     |    | 设计 | 核  |          | 主电路图 |                     |    |                              | 标准   | GB       |
|    |     |     |     |    | 校对 | 准  |          |      |                     |    |                              | 机器电压 | 3/N/400V |
| 标记 | 更改前 | 更改后 | 更改人 | 日期 | 审核 | 日期 | 20221013 |      |                     |    |                              | 机器频率 | 50Hz     |

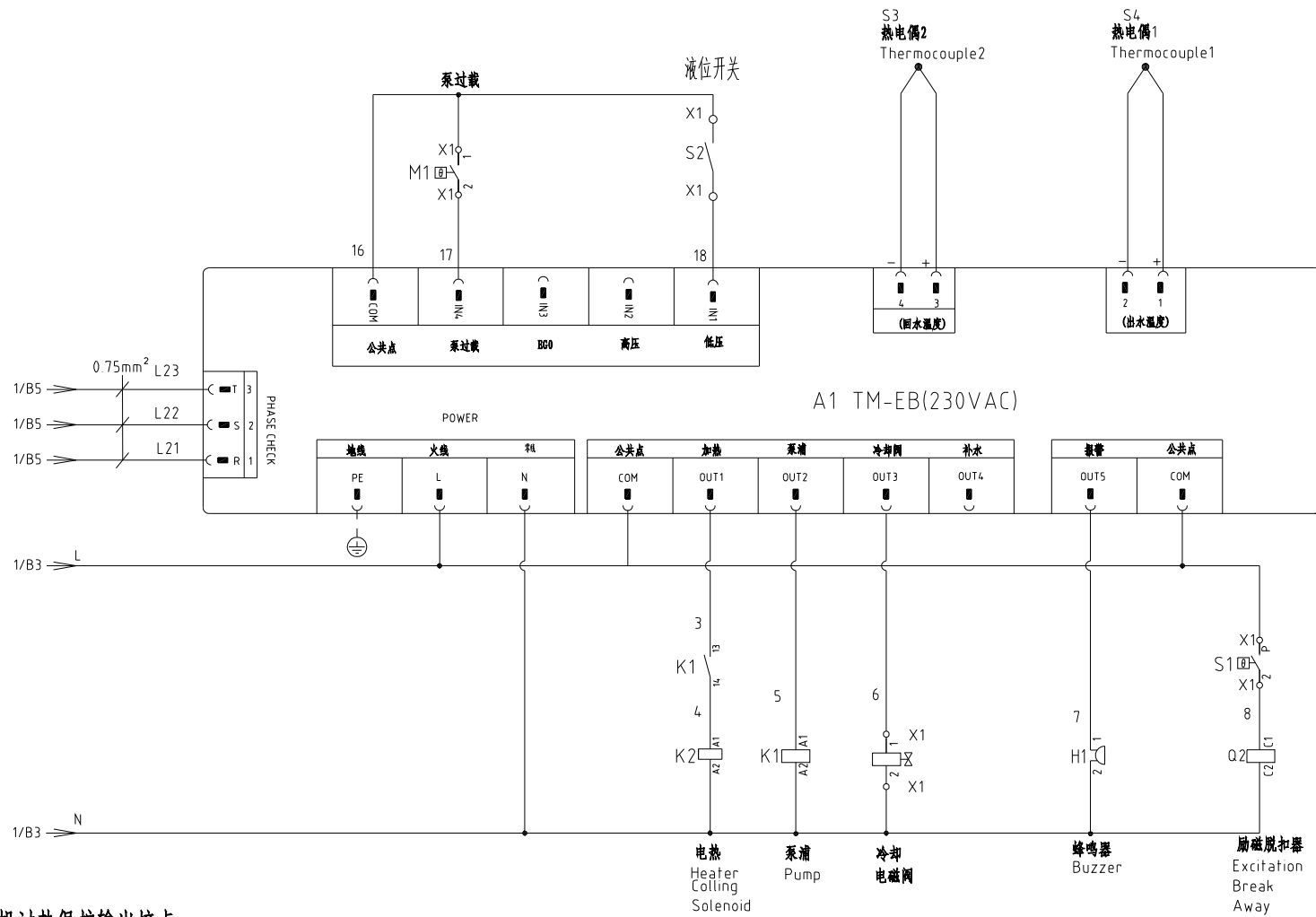

1 2 3 4 5 6 7 8



注：M1为水泵电机过热保护输出接点。

|    |     |     |     |    |    |    |          |   |                              |      |          |
|----|-----|-----|-----|----|----|----|----------|---|------------------------------|------|----------|
|    |     |     |     |    | 制图 | 版号 | D        | 标题  | 图号                           | 比例   | 第 2 张    |
|    |     |     |     |    | 设计 | 核准 |          | STM-607/910/1220-EB   | STM-607/910/1220-EB-400V-D-2 | 标准   | 共 5 张    |
|    |     |     |     |    | 校对 | 核准 |          |  <b>信易电热机械股份有限公司</b><br><b>Shini Plastics Technologies, Inc.</b> |                              | 机器电压 | 3/N/400V |
| 标记 | 更改前 | 更改后 | 更改人 | 日期 | 审核 | 日期 | 20221013 |   |                              | 机器频率 | 50Hz     |

技术要求：(1)热电偶正(+)负(-)极直接接到线路板的热电偶输入端，不经过端子排。

(2)电热和泵浦直接接接触器输出端。

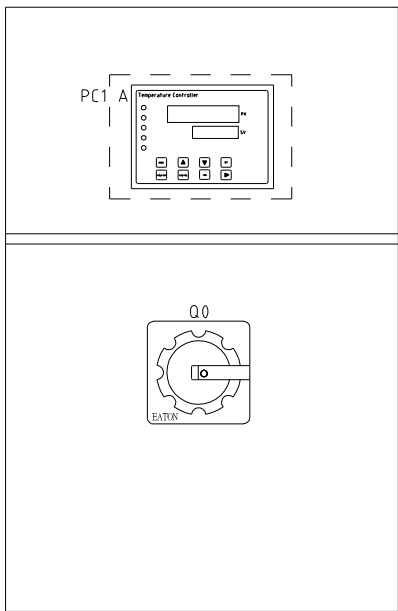

电箱面板

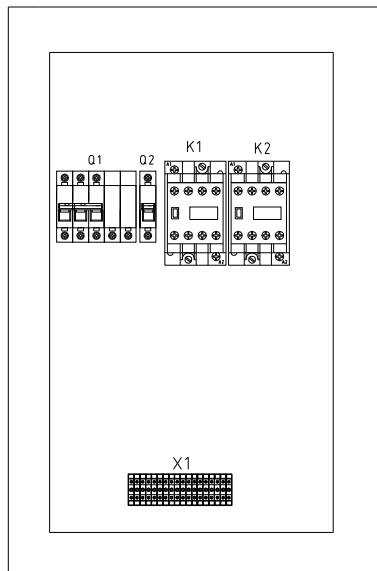

电箱底板

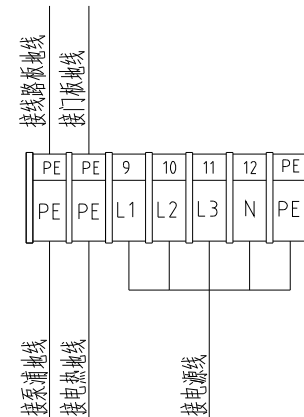
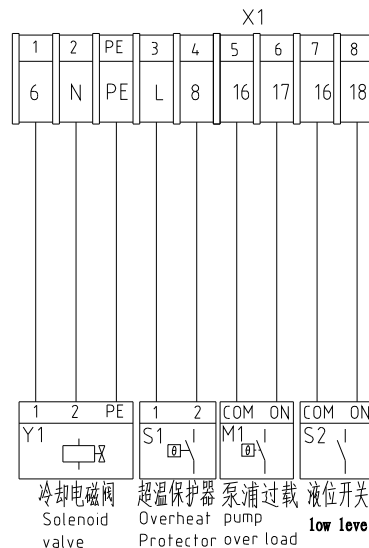

|    |     |     |     |    |    |    |          |            |                     |    |                              |      |          |
|----|-----|-----|-----|----|----|----|----------|------------|---------------------|----|------------------------------|------|----------|
|    |     |     |     |    | 制图 | 版号 | D        | 标题         | STM-607/910/1220-EB | 图号 | STM-607/910/1220-EB-400V-D-3 | 比例   | 第 3 张    |
|    |     |     |     |    | 设计 | 核  |          | 电气布置及端子接线图 |                     |    |                              | 标准   | GB       |
|    |     |     |     |    | 校对 | 准  |          |            |                     |    |                              | 机器电压 | 3/N/400V |
| 标记 | 更改前 | 更改后 | 更改人 | 日期 | 审核 | 日期 | 20221013 |            |                     |    |                              | 机器频率 | 50Hz     |



信易电热机械股份有限公司  
Shini Plastics Technologies, Inc.

1

2

3

4

5

6

7

8

| 1  |           | 2                    |                             | 3                |         | 4                   |                         | 5                |                  | 6         |                      | 7             |                              | 8        |          |  |   |  |                            |
|--|-----------|----------------------|-----------------------------|------------------|---------|---------------------|-------------------------|------------------|------------------|-----------|----------------------|---------------|------------------------------|----------|----------|--|---|--|----------------------------|
| 序号/NO                                    | 符号/Symbol | 名称/Name              |                             | 制造商/Manufacturer |         | 型号/Type             |                         | 规格/Specification |                  | 数量/Number | 物料编号/Material number |               | 备注/Remark                    |          |          |  |   |  |                            |
| A  | 1         | Q1                   | 断路器/Circuit Breakers        |                  | TECO    |                     | BM-63C                  |                  | 16A              |           | 1                    | YE40301603000 |                              | 607-EB用  |          |  |   |  |                            |
|  | 2         |                      | 断路器/Circuit Breakers        |                  | TECO    |                     | BM-63S                  |                  | 25A              |           | 1                    | YE40302503000 |                              | 910-EB用  |          |  |   |  |                            |
|  | 3         |                      | 断路器/Circuit Breakers        |                  | TECO    |                     | BM-63C/3032S            |                  | 32A              |           | 1                    | YE40303203000 |                              | 1220-EB用 |          |  |   |  |                            |
|  | 4         |                      | 励磁脱扣器/Excitation Break Away |                  | CHINT   |                     | MX                      |                  | 230VAC           |           | 1                    | YE40023560000 |                              |          |          |  |   |  |                            |
|  | 5         | Q2                   | 断路器/Circuit Breakers        |                  | TECO    |                     | BM-63C/1003S            |                  | 3A               |           | 1                    | YE40100203000 |                              |          |          |  |   |  |                            |
|  | 6         | K1                   | 接触器/Contactors              |                  | SIEMENS |                     | 3RT6015-1AN21           |                  | 220V 50/60Hz     |           | 1                    | YE00601521000 |                              |          |          |  |   |  |                            |
|  | 7         | K2                   | 接触器/Contactors              |                  | SIEMENS |                     | 3RT6018-1AN21           |                  | 220V 50/60Hz     |           | 1                    | YE00601800000 |                              | 607-EB用  |          |  |   |  |                            |
| B  | 8         |                      | 接触器/Contactors              |                  | SIEMENS |                     | 3RT6026-1AN20           |                  | 220V 50/60Hz     |           | 1                    | YE00602622000 |                              | 910-EB用  |          |  |   |  |                            |
|  | 9         |                      | 接触器/Contactors              |                  | SIEMENS |                     | 3RT6027-1AN20           |                  | 220V 50/60Hz     |           | 1                    | YE00602722000 |                              | 1220-EB用 |          |  |   |  |                            |
|  | 10        | A1 TM-EB             | 线路板/Circuit Board           |                  | YUYUN   |                     | TM-EB 220VAC 宇韻         |                  | 180~430V 50/60Hz |           | 1                    | YE81081100100 |                              |          |          |  |   |  |                            |
|  | 11        | S1                   | 突跳式超温保护器/Overheat Protector |                  | ---     |                     | KSD301-20.5/10BL16K30-G |                  | /205/常开 205度     |           | 1                    | YE90030100300 |                              | (1)      |          |  |   |  |                            |
|  | 12        | S2                   | 微动开关/Limit Switch           |                  | JUCHE   |                     | LXW5-1124 桿長100MM       |                  | 250V 50HZ        |           | 1                    | YE14152400000 |                              | (1)      |          |  |   |  |                            |
|  | 13        | S3                   | 热电偶/Thermocouple            |                  | SHINI   |                     | ----                    |                  | K                |           | 1                    | ----          |                              | (1) (2)  |          |  |   |  |                            |
|  | 14        | S4                   | 热电偶/Thermocouple            |                  | SHINI   |                     | ----                    |                  | K                |           | 1                    | ----          |                              | (1) (2)  |          |  |   |  |                            |
| C  | 15        |                      |                             |                  |         |                     |                         |                  |                  |           |                      |               |                              |          |          |  |   |  |                            |
|  | 16        | X1                   | 端子排/Terminal Board          |                  | PHOENIX |                     | 2.5mm <sup>2</sup>      |                  | ----             |           | 12                   | YE61250040000 |                              | 607-EB用  |          |  |   |  |                            |
|  | 17        |                      | 接地端子排/Terminal Board        |                  | PHOENIX |                     | 2.5mm <sup>2</sup> PE   |                  | ----             |           | 4                    | YE61253500000 |                              | 607-EB用  |          |  |   |  |                            |
|  | 18        |                      | 端子排/Terminal Board          |                  | PHOENIX |                     | 2.5mm <sup>2</sup>      |                  | ----             |           | 8                    | YE61250040000 |                              | 910-EB用  |          |  |   |  |                            |
|  | 19        |                      | 接地端子排/Terminal Board        |                  | PHOENIX |                     | 2.5mm <sup>2</sup> PE   |                  | ----             |           | 1                    | YE61253500000 |                              | 910-EB用  |          |  |   |  |                            |
|  | 20        |                      | 端子排/Terminal Board          |                  | PHOENIX |                     | 4.0mm <sup>2</sup>      |                  | ----             |           | 4                    | YE61040000000 |                              | 910-EB用  |          |  |   |  |                            |
|  | 21        |                      | 接地端子排/Terminal Board        |                  | PHOENIX |                     | 4.0mm <sup>2</sup> PE   |                  | ----             |           | 3                    | YE61043500000 |                              | 910-EB用  |          |  |   |  |                            |
|  | 22        |                      | 端子排/Terminal Board          |                  | PHOENIX |                     | 2.5mm <sup>2</sup>      |                  | ----             |           | 8                    | YE61250040000 |                              | 1220-EB用 |          |  |   |  |                            |
|  | 23        |                      | 接地端子排/Terminal Board        |                  | PHOENIX |                     | 2.5mm <sup>2</sup> PE   |                  | ----             |           | 1                    | YE61253500000 |                              | 1220-EB用 |          |  |   |  |                            |
|  | 24        |                      | 端子排/Terminal Board          |                  | PHOENIX |                     | 6mm <sup>2</sup>        |                  | ----             |           | 4                    | YE61060000000 |                              | 1220-EB用 |          |  |   |  |                            |
| 25                                       |           | 接地端子排/Terminal Board |                             | ----             |         | 6mm <sup>2</sup> PE |                         | ----             |                  | 3         | YE61063500000        |               | 1220-EB用                     |          |          |  |   |  |                            |
| 注: (1)表示非电控箱内材料; (2)表示选配出水 and 回水温度显示功能; |           |                      |                             |                  |         |                     |                         |                  |                  |           |                      |               |                              |          |          |  |   |  |                            |
| D  |           |                      |                             |                  | 制图      |                     | 版号                      |                  | D                |           | 标题                   |               | 图号                           |          | 比例       |  |   |  |                            |
|  |           |                      |                             |                  | 设计      |                     | 核                       |                  |                  |           | STM-607/910/1220-EB  |               | STM-607/910/1220-EB-400V-D-4 |          | 第 4 张    |  |   |  |                            |
|  |           |                      |                             |                  | 校对      |                     | 准                       |                  |                  |           | 元件明细表一               |               | 标准                           |          | GB 共 5 张 |  |   |  |                            |
|  | 标记        |                      | 更改前                         |                  | 更改后     |                     | 更改人                     |                  | 日期               |           | 审核                   |               | 日期                           |          | 20221013 |  |  <b>信易電熱機械股份有限公司</b><br><b>Shini Plastics Technologies, Inc.</b> |  | 机器电压 3/N/400V<br>机器频率 50Hz |
| 1  |           | 2                    |                             | 3                |         | 4                   |                         | 5                |                  | 6         |                      | 7             |                              | 8        |          |  |   |  |                            |

| 1                                    |           | 2       |                    | 3                |       | 4       |               | 5                |                  | 6   |                      | 7              |           | 8                            |  |
|--------------------------------------|-----------|---------|--------------------|------------------|-------|---------|---------------|------------------|------------------|---|----------------------|----------------|-----------|------------------------------|--|
| 序号/NO                                | 符号/Symbol | 名称/Name |                    | 制造商/Manufacturer |       | 型号/Type |               | 规格/Specification |                  | 数量/Number   | 物料编号/Material number |                | 备注/Remark |                              |  |
| A                                    | 1         | M1      | 马达/Motor           |                  | SHINI |         | TP-55         |                  | 400V 50Hz 0.55kW |   | 1                    | ----           |           | (1) 607-EB用                  |  |
|                                      | 2         |         | 马达/Motor           |                  | SHINI |         | TP-75         |                  | 400V 50Hz 0.75kW |   | 1                    | ----           |           | (1) 910-EB用                  |  |
|                                      | 3         |         | 马达/Motor           |                  | SHINI |         | TP-150        |                  | 400V 50Hz 1.5kW  |   | 1                    | ----           |           | (1) 1220-EB用                 |  |
|                                      | 4         | EH      | 电热/Heater          |                  | SHINI |         | 6kW           |                  | 400V 50Hz        |   | 1                    | ----           |           | (1) 607-EB用                  |  |
|                                      | 5         |         | 电热/Heater          |                  | SHINI |         | 9kW           |                  | 400V 50Hz        |   | 1                    | ----           |           | (1) 910-EB用                  |  |
|                                      | 6         |         | 电热/Heater          |                  | SHINI |         | 12kW          |                  | 400V 50Hz        |   | 1                    | ----           |           | (1) 1220-EB用                 |  |
|                                      | 7         | H1      | 蜂鸣器/Buzzer         |                  | SHINI |         | PF-35A        |                  | 230VAC 50Hz      |   | 1                    | YE84003500000  |           |                              |  |
| B                                    | 8         | Y1      | 电磁阀/Solenoid Valve |                  | ----  |         | ----          |                  | 230VAC 50/60Hz   |   | 1                    | ----           |           | (1)                          |  |
|                                      | 9         | Q0      | 主电源开关/Main swith   |                  | EATON |         | T0-2-1/EA/SVB |                  | 20A              |   | 1                    | YE1 0021160000 |           | 607W-EB用                     |  |
|                                      | 10        |         | 主电源开关/Main swith   |                  | EATON |         | P1-25/EA/SVB  |                  | 25A              |   | 1                    | YE10125250000  |           | 910W-EB用                     |  |
|                                      | 11        |         | 主电源开关/Main swith   |                  | EATON |         | P1-32/EA/SVB  |                  | 32A              |   | 1                    | YE10323200000  |           | 1220W-EB用                    |  |
|                                      | 12        |         |                    |                  |       |         |               |                  |                  |   |                      |                |           |                              |  |
|                                      | 13        |         |                    |                  |       |         |               |                  |                  |   |                      |                |           |                              |  |
|                                      | 14        |         |                    |                  |       |         |               |                  |                  |   |                      |                |           |                              |  |
| 15                                   |           |         |                    |                  |       |         |               |                  |                  |   |                      |                |           |                              |  |
| C                                    | 16        |         |                    |                  |       |         |               |                  |                  |   |                      |                |           |                              |  |
|                                      | 17        |         |                    |                  |       |         |               |                  |                  |   |                      |                |           |                              |  |
|                                      | 18        |         |                    |                  |       |         |               |                  |                  |   |                      |                |           |                              |  |
|                                      | 19        |         |                    |                  |       |         |               |                  |                  |   |                      |                |           |                              |  |
|                                      | 20        |         |                    |                  |       |         |               |                  |                  |   |                      |                |           |                              |  |
|                                      | 21        |         |                    |                  |       |         |               |                  |                  |   |                      |                |           |                              |  |
|                                      | 22        |         |                    |                  |       |         |               |                  |                  |   |                      |                |           |                              |  |
|                                      | 23        |         |                    |                  |       |         |               |                  |                  |   |                      |                |           |                              |  |
| D                                    | 24        |         |                    |                  |       |         |               |                  |                  |   |                      |                |           |                              |  |
|                                      | 25        |         |                    |                  |       |         |               |                  |                  |   |                      |                |           |                              |  |
| 注: (1)表示非电控箱内材料; (2)表示选配出水和回水温度显示功能; |           |         |                    |                  |       |         |               |                  |                  |   |                      |                |           |                              |  |
|                                      |           |         |                    |                  |       | 制图      |               | 版号               |                  | D   |                      | 标题             |           | STM-607/910/1220-EB          |  |
|                                      |           |         |                    |                  |       | 设计      |               | 核                |                  |   |                      | 图号             |           | STM-607/910/1220-EB-400V-D-5 |  |
|                                      |           |         |                    |                  |       | 校对      |               | 准                |                  |   |                      | 比例             |           | 第 5 张                        |  |
| 标记                                   |           | 更改前     |                    | 更改后              |       | 更改人     |               | 日期               |                  | 20221013  |                      | 标准             |           | GB 共 5 张                     |  |
| 1                                    |           | 2       |                    | 3                |       | 4       |               | 5                |                  | 6   |                      | 7              |           | 8                            |  |
|                                      |           |         |                    |                  |       |         |               | SHINI            |                  | 信易电热机械股份有限公司<br>Shini Plastics Technologies, Inc. |                      | 机器电压           |           | 3/N/400V                     |  |
|                                      |           |         |                    |                  |       |         |               |                  |                  |   |                      | 机器频率           |           | 50Hz                         |  |

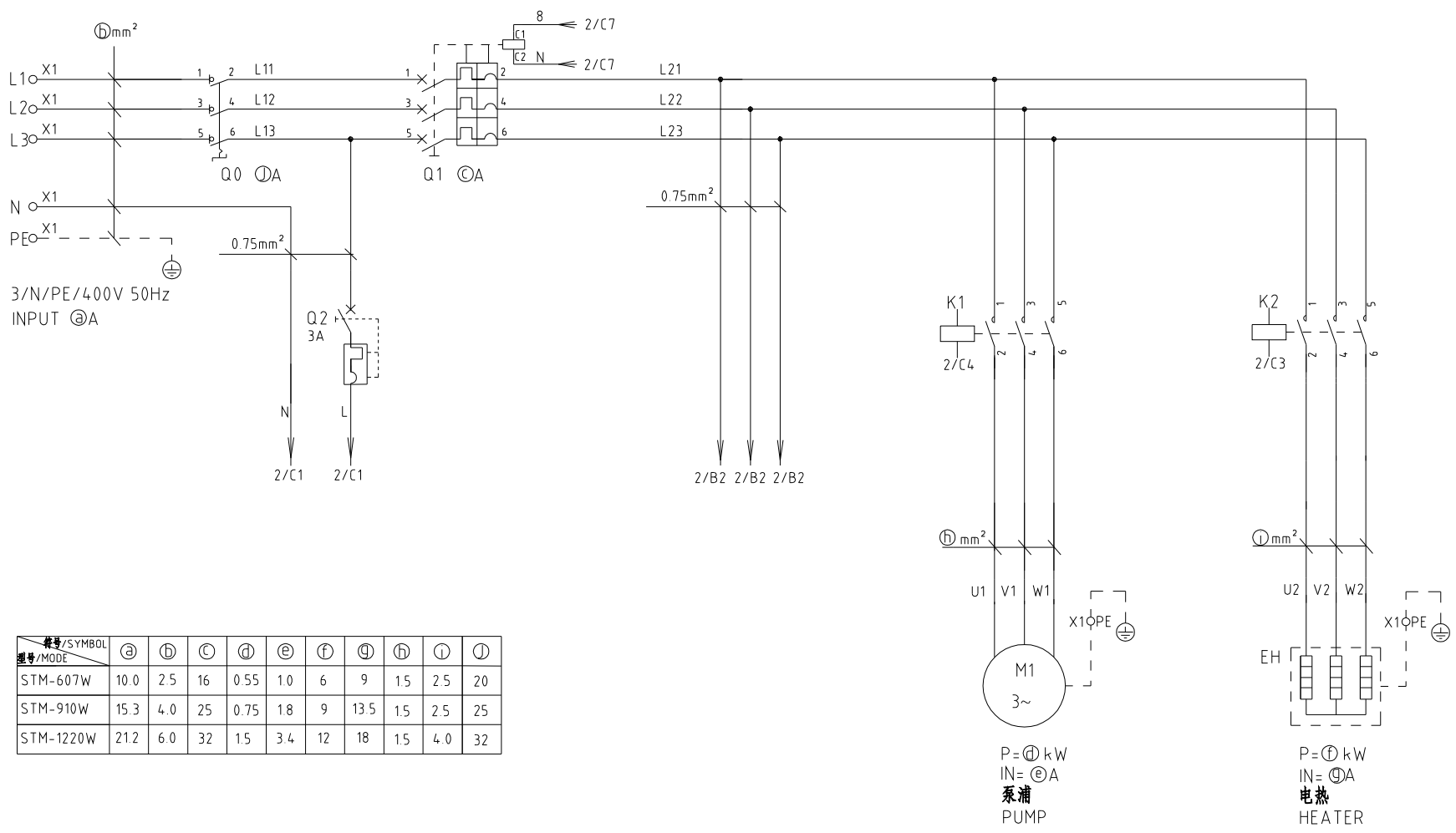

| 符号/SYMBOL<br>型号/MODE | ⓐ    | ⓑ   | ⓒ  | ⓓ    | ⓔ   | ⓕ  | ⓖ    | ⓗ   | ⓘ   | ⓙ  |
|----------------------|------|-----|----|------|-----|----|------|-----|-----|----|
| STM-607W             | 10.0 | 2.5 | 16 | 0.55 | 1.0 | 6  | 9    | 1.5 | 2.5 | 20 |
| STM-910W             | 15.3 | 4.0 | 25 | 0.75 | 1.8 | 9  | 13.5 | 1.5 | 2.5 | 25 |
| STM-1220W            | 21.2 | 6.0 | 32 | 1.5  | 3.4 | 12 | 18   | 1.5 | 4.0 | 32 |

|    |     |     |     |    |    |    |          |      |                      |    |                               |      |          |
|----|-----|-----|-----|----|----|----|----------|------|----------------------|----|-------------------------------|------|----------|
|    |     |     |     |    | 制图 | 版号 | D        | 标题   | STM-607/910/1220W-EB | 图号 | STM-607/910/1220W-EB-400V-D-1 | 比例   | 第 1 张    |
|    |     |     |     |    | 设计 | 核  |          | 主电路图 |                      |    |                               | 标准   | 共 5 张    |
|    |     |     |     |    | 校对 | 准  |          |      |                      |    |                               | 机器电压 | 3/N/400V |
| 标记 | 更改前 | 更改后 | 更改人 | 日期 | 审核 | 日期 | 20221013 |      |                      |    |                               | 机器频率 | 50Hz     |



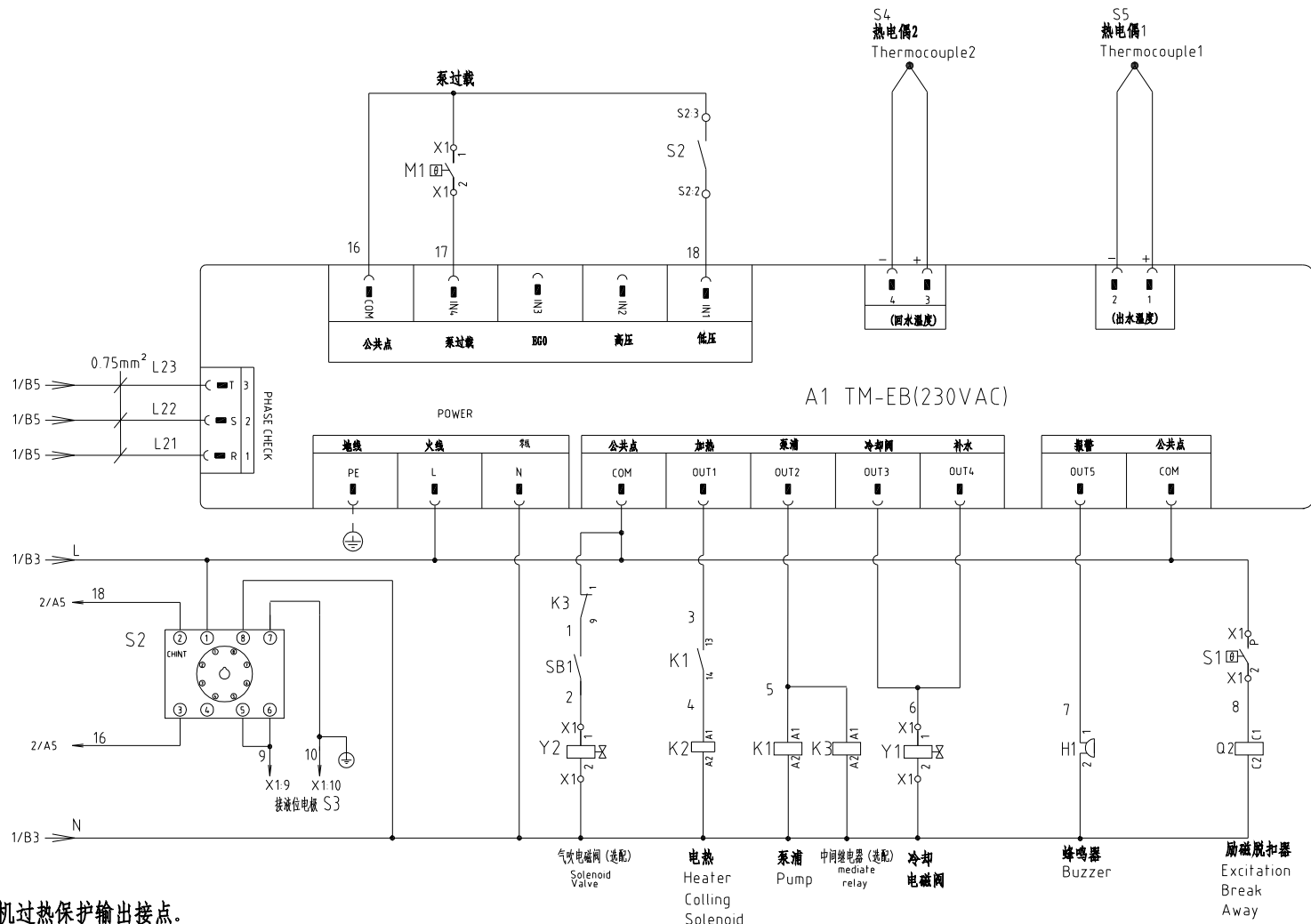

|    |     |     |     |    |    |    |          |   |                      |      |                               |       |       |
|----|-----|-----|-----|----|----|----|----------|---|----------------------|------|-------------------------------|-------|-------|
|    |     |     |     |    | 制图 | 版号 | D        | 标题  | STM-607/910/1220W-EB | 图号   | STM-607/910/1220W-EB-400V-D-2 | 比例    | 第 2 张 |
|    |     |     |     |    | 设计 | 核准 |          | 控制电路图   |                      | 标准   | GB                            | 共 5 张 |       |
|    |     |     |     |    | 校对 | 日期 | 20221013 |  <b>信易电热机械股份有限公司</b><br><b>Shini Plastics Technologies, Inc.</b> |                      | 机器电压 | 3/N/400V                      |       |       |
| 标记 | 更改前 | 更改后 | 更改人 | 日期 | 审核 | 日期 | 20221013 |   |                      | 机器频率 | 50Hz                          |       |       |

技术要求：(1)热电偶正(+)负(-)极直接接到线路板的热电偶输入端，不经过端子排。

(2)电热和泵浦直接接接触器输出端。

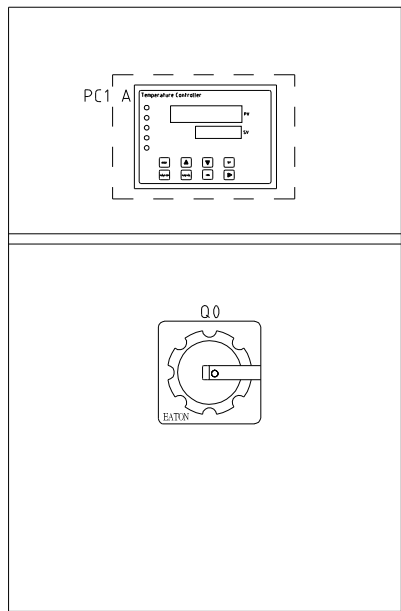

电箱面板

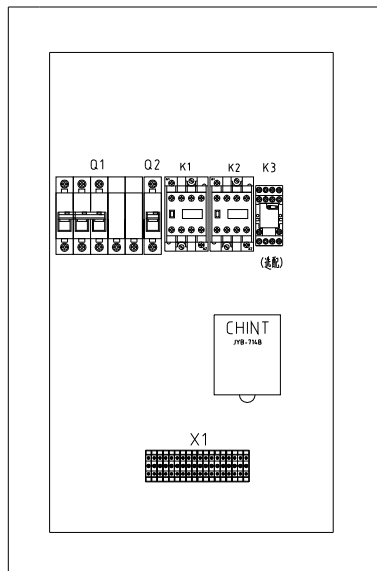

电箱底板

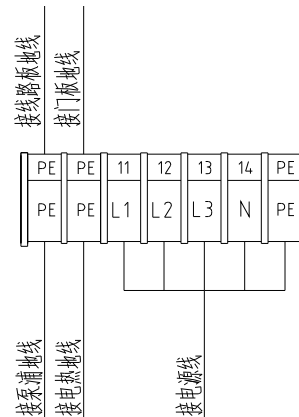
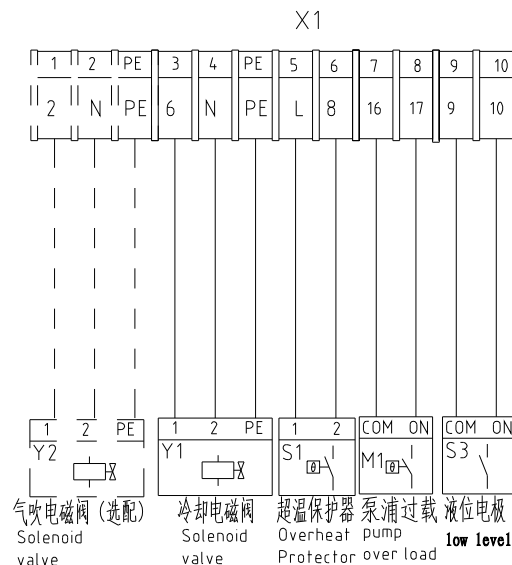

|    |     |     |     |    |    |    |          |  |                      |      |                               |          |       |
|----|-----|-----|-----|----|----|----|----------|--|----------------------|------|-------------------------------|----------|-------|
|    |     |     |     |    | 制图 | 版号 | D        | 标题   | STM-607/910/1220W-EB | 图号   | STM-607/910/1220W-EB-400V-D-3 | 比例       | 第 3 张 |
|    |     |     |     |    | 设计 | 核  |          | 电气布置及端子接线图   |                      |      |                               | 标准       | GB    |
|    |     |     |     |    | 校对 | 准  |          |  <b>信易电热机械股份有限公司</b><br>Shini Plastics Technologies, Inc. |                      | 机器电压 |                               | 3/N/400V |       |
| 标记 | 更改前 | 更改后 | 更改人 | 日期 | 审核 | 日期 | 20221013 |  |                      | 机器频率 |                               | 50Hz     |       |

1

2

3

4

5

6

7

8



| 1  |           | 2        |                             | 3          |                       | 4                |                      | 5             |   | 6                    |                               | 7        |    | 8     |       |
|--|-----------|----------|-----------------------------|------------|-----------------------|------------------|----------------------|---------------|---|----------------------|-------------------------------|----------|----|-------|-------|
| 序号/NO  | 符号/Symbol | 名称/Name  | 制造商/Manufacturer            | 型号/Type    | 规格/Specification      | 数量/Number        | 物料编号/Material number | 备注/Remark     |   |                      |                               |          |    |       |       |
| A  | 1         | Q1       | 断路器/Circuit Breakers        | TECO       | BM-63C                | 16A              | 1                    | YE40301603000 | 607W-EB用  | A                    |                               |          |    |       |       |
|  | 2         |          | 断路器/Circuit Breakers        | TECO       | BM-63S                | 25A              | 1                    | YE40302503000 | 910W-EB用  |                      |                               |          |    |       |       |
|  | 3         |          | 断路器/Circuit Breakers        | TECO       | BM-63C/3032S          | 32A              | 1                    | YE40303203000 | 1220W-EB用   |                      |                               |          |    |       |       |
|  | 4         |          | 励磁脱扣器/Excitation Break Away | CHINT      | MX                    | 230VAC           | 1                    | YE40023560000 |   |                      |                               |          |    |       |       |
|  | 5         | Q2       | 断路器/Circuit Breakers        | TECO       | BM-63C/1003S          | 3A               | 1                    | YE40100203000 |   |                      |                               |          |    |       |       |
|  | 6         | K1       | 接触器/Contactors              | SIEMENS    | 3RT6015-1AN21         | 220V 50/60Hz     | 1                    | YE00601521000 |   |                      |                               |          |    |       |       |
|  | 7         | K2       | 接触器/Contactors              | SIEMENS    | 3RT6018-1AN21         | 220V 50/60Hz     | 1                    | YE00601800000 | 607W-EB用  |                      |                               |          |    |       |       |
| B  | 8         |          | 接触器/Contactors              | SIEMENS    | 3RT6026-1AN20         | 220V 50/60Hz     | 1                    | YE00602622000 | 910W-EB用  | B                    |                               |          |    |       |       |
|  | 9         |          | 接触器/Contactors              | SIEMENS    | 3RT6027-1AN20         | 220V 50/60Hz     | 1                    | YE00602722000 | 1220W-EB用   |                      |                               |          |    |       |       |
|  | 10        | K3       | 中間繼電器/mediate relay         | WEIDMULLER | DRM270730LT           | 220V 50/60Hz     | 1                    | YE03270700000 | (2)   |                      |                               |          |    |       |       |
|  | 11        | SB1      | 切替開關/Switch                 | ----       | R210-C5LBW4P          | 220V 50/60Hz     | 1                    | YE10210400000 | (2)   |                      |                               |          |    |       |       |
|  | 12        | A1 TM-EB | 线路板/Circuit Board           | YUYUN      | TM-EB 220VAC 字額       | 180~430V 50/60Hz | 1                    | YE81081100100 |   |                      |                               |          |    |       |       |
|  | 13        | H1       | 蜂鸣器/Buzzer                  | SHINI      | PF-35A                | 230VAC 50Hz      | 1                    | YE84003500000 |   |                      |                               |          |    |       |       |
|  | 14        |          |                             |            |                       |                  |                      |               |   |                      |                               |          |    |       |       |
| C  | 15        | X1       | 端子排/Terminal Board          | PHOENIX    | 2.5mm <sup>2</sup>    | ----             | 12                   | YE61250040000 | 607W-EB用  | C                    |                               |          |    |       |       |
|  | 16        |          | 接地端子排/Terminal Board        | PHOENIX    | 2.5mm <sup>2</sup> PE | ----             | 4                    | YE61253500000 | 607W-EB用  |                      |                               |          |    |       |       |
|  | 17        |          | 端子排/Terminal Board          | PHOENIX    | 2.5mm <sup>2</sup>    | ----             | 8                    | YE61250040000 | 910W-EB用  |                      |                               |          |    |       |       |
|  | 18        |          | 接地端子排/Terminal Board        | PHOENIX    | 2.5mm <sup>2</sup> PE | ----             | 1                    | YE61253500000 | 910W-EB用  |                      |                               |          |    |       |       |
|  | 19        |          | 端子排/Terminal Board          | PHOENIX    | 4.0mm <sup>2</sup>    | ----             | 4                    | YE61040000000 | 910W-EB用  |                      |                               |          |    |       |       |
|  | 20        |          | 接地端子排/Terminal Board        | PHOENIX    | 4.0mm <sup>2</sup> PE | ----             | 3                    | YE61043500000 | 910W-EB用  |                      |                               |          |    |       |       |
|  | 21        |          | 端子排/Terminal Board          | PHOENIX    | 2.5mm <sup>2</sup>    | ----             | 8                    | YE61250040000 | 1220W-EB用   |                      |                               |          |    |       |       |
|  | 22        |          | 接地端子排/Terminal Board        | PHOENIX    | 2.5mm <sup>2</sup> PE | ----             | 1                    | YE61253500000 | 1220W-EB用   |                      |                               |          |    |       |       |
|  | 23        |          | 端子排/Terminal Board          | PHOENIX    | 6mm <sup>2</sup>      | ----             | 4                    | YE61060000000 | 1220W-EB用   |                      |                               |          |    |       |       |
|  | 24        |          | 接地端子排/Terminal Board        | ----       | 6mm <sup>2</sup> PE   | ----             | 3                    | YE61063500000 | 1220W-EB用   |                      |                               |          |    |       |       |
| 25   |           |          |                             |            |                       |                  |                      |               |   |                      |                               |          |    |       |       |
| 注: (1)表示非电控箱内材料; (2)表示气吹功能选配件; (3)表示选配出水和回水温度显示功能; |           |          |                             |            |                       |                  |                      |               |   |                      |                               |          |    |       |       |
| D  |           |          |                             |            |                       | 制图               | 版号                   | D             | 标题  | STM-607/910/1220W-EB | 图号                            |          |    | 比例    | 第 4 张 |
|  |           |          |                             |            |                       | 设计               | 核                    |               | 元件明细表一  |                      | STM-607/910/1220W-EB-400V-D-4 | 标准       | GB | 共 5 张 |       |
|  |           |          |                             |            |                       | 校对               | 准                    |               |  <b>信易電熱機械股份有限公司</b><br><b>Shini Plastics Technologies, Inc.</b> |                      | 机器电压                          | 3/N/400V |    |       |       |
|  | 标记        | 更改前      | 更改后                         | 更改人        | 日期                    | 审核               | 日期                   | 20221013      |   |                      | 机器频率                          | 50Hz     |    |       |       |
| 1  |           | 2        |                             | 3          |                       | 4                |                      | 5             |   | 6                    |                               | 7        |    | 8     |       |

| 1     | 2         | 3                         | 4                | 5                     | 6                | 7         | 8                    |               |
|-------|-----------|---------------------------|------------------|-----------------------|------------------|-----------|----------------------|---------------|
| 序号/NO | 符号/Symbol | 名称/Name                   | 制造商/Manufacturer | 型号/Type               | 规格/Specification | 数量/Number | 物料编号/Material number | 备注/Remark     |
| A     | M1        | 马达/Motor                  | SHINI            | TP-55                 | 400V 50Hz 0.55kW | 1         | ----                 | (1) 607W-EB用  |
|       |           | 马达/Motor                  | SHINI            | TP-75                 | 400V 50Hz 0.75kW | 1         | ----                 | (1) 910W-EB用  |
|       |           | 马达/Motor                  | SHINI            | TP-150                | 400V 50Hz 1.5kW  | 1         | ----                 | (1) 1220W-EB用 |
|       | EH        | 电热/Heater                 | SHINI            | 6kW                   | 400V 50Hz        | 1         | ----                 | (1) 607W-EB用  |
|       |           | 电热/Heater                 | SHINI            | 9kW                   | 400V 50Hz        | 1         | ----                 | (1) 910W-EB用  |
|       |           | 电热/Heater                 | SHINI            | 12kW                  | 400V 50Hz        | 1         | ----                 | (1) 1220W-EB用 |
|       | S1        | 超温保护器/Overheat Protector  | ----             | KSD301-12.5/10BL16K20 | 125℃             | 1         | YE90030100000        | (1)           |
| B     | S2        | 液位控制器/Liquid level switch | CHINT            | JYB-714B              | 230VAC 50/60Hz   | 1         | YE03071400000        | (1)           |
|       | S3        | 液位电极/Liquid level         | ----             | ----                  | ----             | 1         | YE90815970000        | (1)           |
|       | S4        | 热电偶/Thermocouple          | SHINI            | ----                  | K                | 1         | ----                 | (1) (3)       |
|       | S5        | 热电偶/Thermocouple          | SHINI            | ----                  | K                | 1         | ----                 | (1) (3)       |
|       | Y1        | 电磁阀/Solenoid Valve        | ----             | ----                  | 230VAC 50/60Hz   | 1         | ----                 | (1)           |
|       | Y2        | 电磁阀/Solenoid Valve        | ----             | ----                  | 230VAC 50/60Hz   | 1         | ----                 | (1) (2)       |
|       | X1        | 端子排/Terminal Board        | PHOENIX          | 2.5mm <sup>2</sup>    | ----             | 2         | YE61250040000        | (2)           |
| C     |           | 接地端子排/Terminal Board      | PHOENIX          | 2.5mm <sup>2</sup> PE | ----             | 1         | YE61253500000        | (2)           |
|       | Q0        | 主电源开关/Main switch         | EATON            | T0-2-1/EA/SVB         | 20A              | 1         | YE10021160000        | 607W-EB用      |
|       |           | 主电源开关/Main switch         | EATON            | P1-25/EA/SVB          | 25A              | 1         | YE10125250000        | 910W-EB用      |
|       |           | 主电源开关/Main switch         | EATON            | P1-32/EA/SVB          | 32A              | 1         | YE10323200000        | 1220W-EB用     |
|       |           |                           |                  |                       |                  |           |                      |               |
|       |           |                           |                  |                       |                  |           |                      |               |
|       |           |                           |                  |                       |                  |           |                      |               |
|       |           |                           |                  |                       |                  |           |                      |               |
|       |           |                           |                  |                       |                  |           |                      |               |
|       |           |                           |                  |                       |                  |           |                      |               |

注：(1)表示非电控箱内材料；(2)表示气吹功能选配件；(3)表示选配出水和回水温度显示功能；

|   |    |     |     |     |    |    |        |                                |    |          |                               |   |
|---|----|-----|-----|-----|----|----|--------|--------------------------------|----|----------|-------------------------------|---|
| D |    |     |     |     |    | 制图 | 版号     | D                              | 标题 | 图号       | 比例                            | 第 5 张   |
|   |    |     |     |     |    | 设计 | 核<br>准 | STM-607/910/1220W-EB<br>元件明细表二 |    |          | STM-607/910/1220W-EB-400V-D-5 |   |
|   |    |     |     |     |    | 校对 |        |                                | 日期 | 20221013 |                               |  <b>信易电热机械股份有限公司</b><br><b>Shini Plastics Technologies, Inc.</b> |
|   | 标记 | 更改前 | 更改后 | 更改人 | 日期 | 审核 | 日期     | 20221013                       |    |          | 机器频率                          |   |
|   | 1  | 2   | 3   | 4   | 5  | 6  | 7      | 8                              |    |          |                               |   |