

SCD

"One-to-Two" Compact Dryer

Date: Mar. 2016

Version: Ver.A (English)



Contents

1. General Description	7
1.1 Coding Principle	8
1.2 Features	8
1.3 Technical Specifications.....	10
1.3.1 Outline Drawings	10
1.3.2 Specifications	10
1.4 Safety Regulations	12
1.4.1 Safety Regulations for the Blowers.....	12
1.4.2 Safety Signs and Labels.....	13
1.4.3 Signs and Labels	14
1.4.4 Transportation and Storage of the Machine.....	14
1.5 Exemption Clause	15
2. Structure Characteristics and Working Principle	16
2.1 Working Principle	16
2.2 Relative Humidity and Dew-point	17
2.3 Drawing and Parts List	17
2.3.1 Structural Drawing	17
2.3.2 Part drawing	18
2.3.3 Parts List.....	19
2.3.4 Honeycomb Assembly	20
2.4 Electrical Diagram	21
2.4.1 Main Circuit.....	21
2.4.2 Control Circuit.....	23
2.4.3 Components Layout	26
2.4.4 Electrical Components List	28
2.5 Options.....	30
2.5.1 Installation for Dewpoint Monitor, Add "D" at the end of the model code. 30	
2.5.2 For models with hopper polished inside, add "P" at the end of the mode code.	32
2.5.3 For models optional with dew-point control, add "DC" at the end	

of the mode code.....	32
2.5.4 Installation Testing.....	33
2.6 Machine Allocation	33
2.7 Duct and Feed Tube Connection	34
2.8 Water Connection	34
2.9 Air Supply Connection.....	35
2.10 Electrical Connections.....	35
3. Application and Operation.....	36
3.1 Dehumidifying System Operation.....	36
3.2 Temperature Setup	36
3.3 PID Auto-tuning Setting.....	36
3.4 Intermittent Running Setup	36
3.5 Weekly Time Start Setup	38
3.6 Present Time Modification.....	39
3.7 Weekly Time Start/Stop	39
3.8 Temperature Unit Selection	39
3.9 Lock Setup	40
3.10 Low-temp. Alarm Setup.....	41
3.10.1 The Value of Low-temp. Alarm	41
3.10.2 Reaction Time of Low-temp. Alarm	42
3.11 Heater Alarm	42
3.12 Low-temp. Alarm	43
3.13 Alarm Description (Dehumidifying System).....	45
3.14 Drying System Operation	46
3.15 Control Panel	46
3.15.1 Operation Step	46
3.15.2 Temperature Setting.....	46
3.15.3 Temperature Lock Setting	46
3.15.4 PID Setting	47
3.15.5 Intermittent Running Setup.....	48
3.15.6 Weekly Time Start Setup.....	48
3.15.7 Communication Setup (Option)	48
3.15.8 Operation process	50
3.15.9 Error code description	51

3.15.10	Panel and Keys Instruction(Suction system)	52
3.15.11	Machine Start/Stop	52
3.15.12	Operation Time Setting	54
3.15.13	Parameter Group 1	54
3.15.14	Parameter Group 2	55
3.15.15	Parameter Group 3	55
3.15.16	Parameter Group 4	57
3.16	Alarm Instruction	57
4.	Trouble-shooting	59
4.1	Error Code Instruction	59
5.	Repair and Maintenance	61
6.	Honeycomb-rotor	62
6.1.1	What is Honeycomb-rotor	62
6.1.2	Installation of the Rotor	62
6.1.3	Cleaning of Honeycomb	64
6.2	Heater Assemblies	65
6.3	Blowers	66
6.3.1	Drying Blower	66
6.3.2	Regeneration Blower	66
6.3.3	Conveying Blower	66
6.3.4	Installation of Drying Hopper	67
6.3.5	Filter & Pressure Regulating Valve	67
6.3.6	EGO	67
6.4	Filter & Pressure Regulating Valve	68
6.4.1	Operation Steps of Filter & Pressure Regulating Valve	68
6.5	Filter	68
6.5.1	The Useful Life of the Key Parts of the Product	69
6.6	Cooler Clear Step	69
6.7	Maintenance Schedule	70
6.7.1	General Machine Information	70
6.7.2	Installation & Inspection	70
6.7.3	Daily Checking	70
6.7.4	Weekly Checking	70

6.7.5 Monthly Checking	71
6.7.6 Half-yearly Checking	71
6.7.7 Yearly Checking	71
6.7.8 3 year Checking.....	71

1. General Description



Read this manual carefully before operation to prevent damage of the machine or personal injuries..

“One-to-Two” “All-in-One” Compact Dryer SCD-80Ux2/100H possesses three functions of dehumidification, drying and four-stage conveying in one unit. It utilizes one dehumidifier to dry materials in two different hoppers simultaneously, and control each hopper temperature separately. It mainly collocated with double-shooting injection molding machine and is very suitable for drying engineering plastics materials with hygroscopicity such as PA, PC, PBT, PET, providing dew-point of below -40°C under ideal condition.



SCD-80Ux2/100H

1.1 Coding Principle

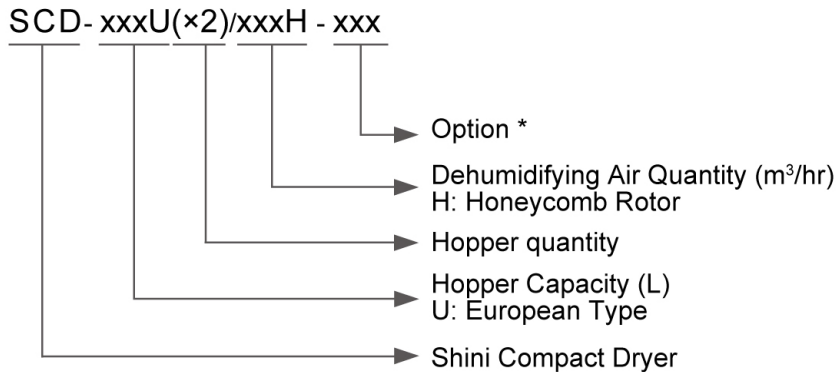

1.2 Features

- Combine the function of dehumidifying, drying and two-stage conveying into a single unit.
- SCD dryers Loaders are equipped with honeycomb rotor to obtain stable low dew-point drying air. It has two models: semi-open and hermetic.
- Feeding system is equipped with shut-off valve to ensure no surplus raw material in hopper tubes.
- surplus raw material in hopper tubes.
- Heat preserved drying hopper barrel adopts down blowpipe design and collocates with cyclone air exhaust to avoid heat lost and improve drying efficiency.
- Equipped with two drying hoppers, the drying temperature of single hopper can be individually controlled. It mainly applied to double-shot molding machine, which can process dehumidifying and drying to two different drying materials.

All service work should be carried out by a person with technical training or corresponding professional experience. The manual contains instructions for both handling and servicing. Chapter 6, which contains service instructions intended for service engineers. Other chapters contain instructions for the daily operator.

Any modifications of the machine must be approved by SHINI in order to avoid personal injury and damage to machine. We shall not be liable for any damage caused by unauthorized change of the machine.

Our company provides excellent after-sales service. Should you have any problem during using the machine, please contact the company or the local vendor.

Headquarter and Taipei factory:

Tel: (886) 2 2680 9119

Shini Plastics Technologies (Dongguan), Inc:

Tel: (86) 769 8111 6600

Shini Plastics Technologies India Pvt.Ltd.:

Tel: (91) 250 3021 166

1.3 Technical Specifications

1.3.1 Outline Drawings

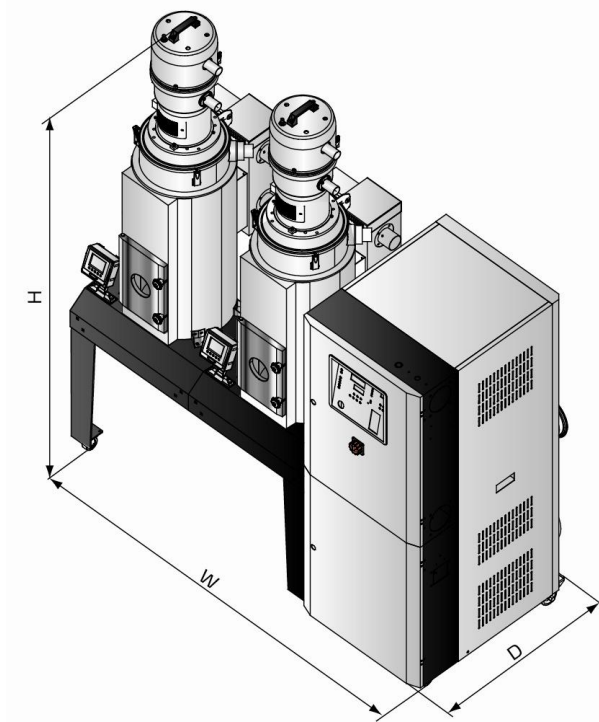

Picture 1-1: Outline Drawings

1.3.2 Specifications

Table 1-1: Specifications

Model SCD-	80Ux2/100H
Ver.	A
Dyeing Heater Power (kW)	3.9x2
Dyeing Blower Power (kW, 50/60Hz)	0.4/0.46
Hopper Capacity (L)	80x2
Regenerating Heater Power (kW)	4
Regenerating Blower Power (kW, 50/60Hz)	0.2/0.24
Dehumidifying Air quantity(m ³ /hr,50/60Hz)	100/111
Feeding Blower Power (kW, 50/60Hz)	1.5/1.6

Dia. of Material Pipe (inch)	1.5
SHR-U-E Hopper (L)	3
SHR-U Hopper (L)	3
Dimensions H x Wx D(mm)	1760 x 920 x1890
Weight (kg)	400

Note: 1) For models with the polished hopper inside, add "P";
add "D" at model behind.
2) Power: 3 Φ , 230/400/460/575VAC, 50/60Hz.

We reserve the right to change specifications without prior notice.

1.4 Safety Regulations

1.4.1 Safety Regulations for the Blowers

- 1) Under normal operation, the blowers will generate high temperature. Do not touch blower's case to avoid any physical injury.
- 2) Under normal operation, the blower motor's current loading will increase or reduce according to air pressure's change accordingly. While installation, an adequate motor overload protection switch should be installed with full loading test, to ensure operating safely under full-loading to avoid motor's damage.
- 3) To avoid any block materials, dust, powder, fiber particles and water drops entering the blower, and hence cause the deficiency of its performance. This machine is well designed with air filters, so please clean up the filter with any foreign particles (recommended to clean up this filter weekly).
- 4) Clean the blowers both internal and external parts (especially for the fan cooling path), and remove surface dust if necessary. If more dusts are accumulated, it will cause deficiency for ventilation, temperature rising, vacuum power reduced, vibration increased and so it will cause machine broke down.
- 5) Ball bearing, oil seal and soundproof are belonging to consumable parts and so it has a life period and equires regular replacement. Meanwhile, blade, external case, and metallic screen etc. should be replaced regularly for best performance.
- 6) Under normal operation, if the blowers are not running smoothly or abnormal noise appeared. Please immediately shut down the machine for repair.



Picture 1-2: Blowers

1.4.2 Safety Signs and Labels



Danger!

High voltage danger!

This label is stuck on the electrical boxes.



Attention!

This label means that this area should be taken care!



Warning!

High temperature, take care of hands!

This label should be stick to the shell of heater.



Attention!

No need for regular inspection because all the electrical parts in the control unit are fixed tightly!



Note!

The EGO over-temperature protection is only for process heater protection, not for material protection usage, the default setting should not be changed.



Note!

To prevent over-temperature alarm from causing machine shutdown, don't randomly adjust EGO setting temp.

1.4.3 Signs and Labels

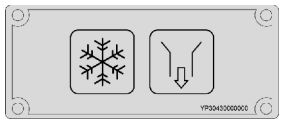
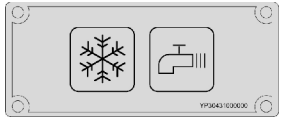
	<p>Water outlet: drainage outlet.</p>
	<p>Water inlet: inlet for replenishing water and cooling water.</p>

1.4.4 Transportation and Storage of the Machine

Transportation

- 1) SCD series "One-to-Two" compact dryer are packed in crates or plywood cases with wooden pallet at the bottom, suitable for quick positioning by fork lift.
- 2) After unpacked, castors equipped on the machine can be used for ease of movement.
- 3) Do not rotate the machine and avoid collision with other objects during transportation to prevent improper functioning.
- 4) The structure of the machine is well-balanced, although it should also be handled with care when lifting the machine for fear of falling down.
- 5) The machine and its attached parts can be kept at a temperature from -25°C to $+55^{\circ}\text{C}$ for long distance transportation and for a short distance, it can be transported with temperature under $+70^{\circ}\text{C}$.

Storage

- 1) SCD series "All-in-One" compact dryer should be stored indoors with temperature kept from 5°C to 40°C and humidity below 80%.
- 2) Disconnect all power supply and turn off main switch and control switch.
- 3) Keep the whole machine, especially the electrical components away from water to avoid potential troubles caused by the water.
- 4) Plastic film should be used to protect the machine from dust and rains.

Working environment

Indoors in a dry environment with max. temperature $+45^{\circ}\text{C}$ and humidity no more than 80%.

Do not use the machine

- 1) If it is with a damaged cord.
- 2) On a wet floor or when it is exposed to rain to avoid electrical shock.
- 3) If it has been dropped or damaged until it is checked or fixed by a qualified serviceman.
- 4) This equipment works normally in the environment with altitude within 3000m.
- 5) At least a clearance of 1m surrounding the equipment is required during operation. Keep this equipment away from flammable sources at least two meters.
- 6) Avoid vibration, magnetic disturbance at the operation area.

Rejected parts disposal

When the equipment has run out its life time and can not be used any more, unplug the power supply and dispose of it properly according to local code.
Fire hazard.



In case of fire, CO₂ dry powder fire extinguisher should be applied.

1.5 Exemption Clause

The following statements clarify the responsibilities and regulations born by any buyer or user who purchases products and accessories from Shini (including employees and agents).

Shini is exempted from liability for any costs, fees, claims and losses caused by reasons below:

1. Any careless or man-made installations, operation and maintenances upon machines without referring to the Manual prior to machine using.
2. Any incidents beyond human reasonable controls, which include man-made vicious or deliberate damages or abnormal power, and machine faults caused by irresistible natural disasters including fire, flood, storm and earthquake.
3. Any operational actions that are not authorized by Shini upon machine, including adding or replacing accessories, dismantling, delivering or repairing.
4. Employing consumables or oil media that are not appointed by Shini.

2. Structure Characteristics and Working Principle

2.1 Working Principle

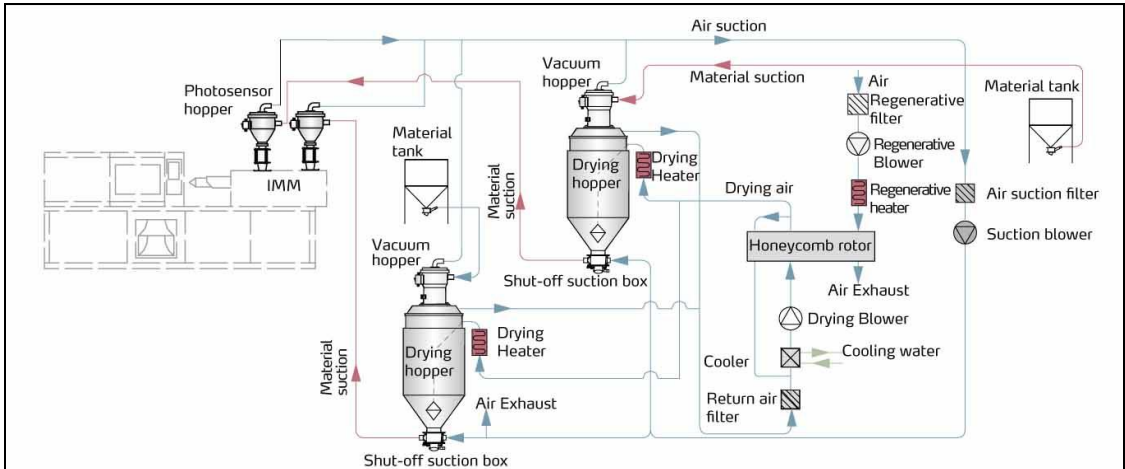

Picture 2-1: Working Principle

Dehumidifying: damp and hot air from two dry material barrels via the filter and condenser is blown into rotor. Moisture from the air is absorbed by rotor, then absorbed and expelled by regeneration heating air with rotor rotation. Two strands of airflow function on the rotor. And with the rotation, moisture from the air is absorbed and expelled after absorbed regeneration air to form stable low dew-point drying air. The low dew-point drying air through heater then get into the two storage barrels separately to dehumidify material in the barrels. The damp and hot air expelled by storage barrel after drying, return to the filter and condenser again to process dehumidifying in the rotor. Thus, the closed circle is formed to dry material.

Suction: material is absorbed into two drying hoppers from different storage barrels or other storage containers. When the magnetic reed switch detects no material, suction motor runs to produce vacuum inside vacuum hopper. Raw material in storage barrels is absorbed into suction hopper due to air pressure difference. When material suction completes, motor stops. Raw materials drop into drying hopper barrel due to gravity. As the same, the dried raw material after dried is taken out to the hopper with photosensor installed on the double-shot molding machine.

2.2 Relative Humidity and Dew-point

Relative humidity: Relative air humidity means real vapor content to saturated vapor at the same temperature in percentage. Dew point: it means that temperature when the saturation vapor begins to dew. When the relative humidity is 100%, the ambient temperature is the dew point temperature. The more lower of dew point temperature (than the ambient temperature) is, the more less possible to dew, that also means the more drier the air is. The dew point will not be influenced by temperature, but influenced by pressure.

2.3 Drawing and Parts List

2.3.1 Structural Drawing

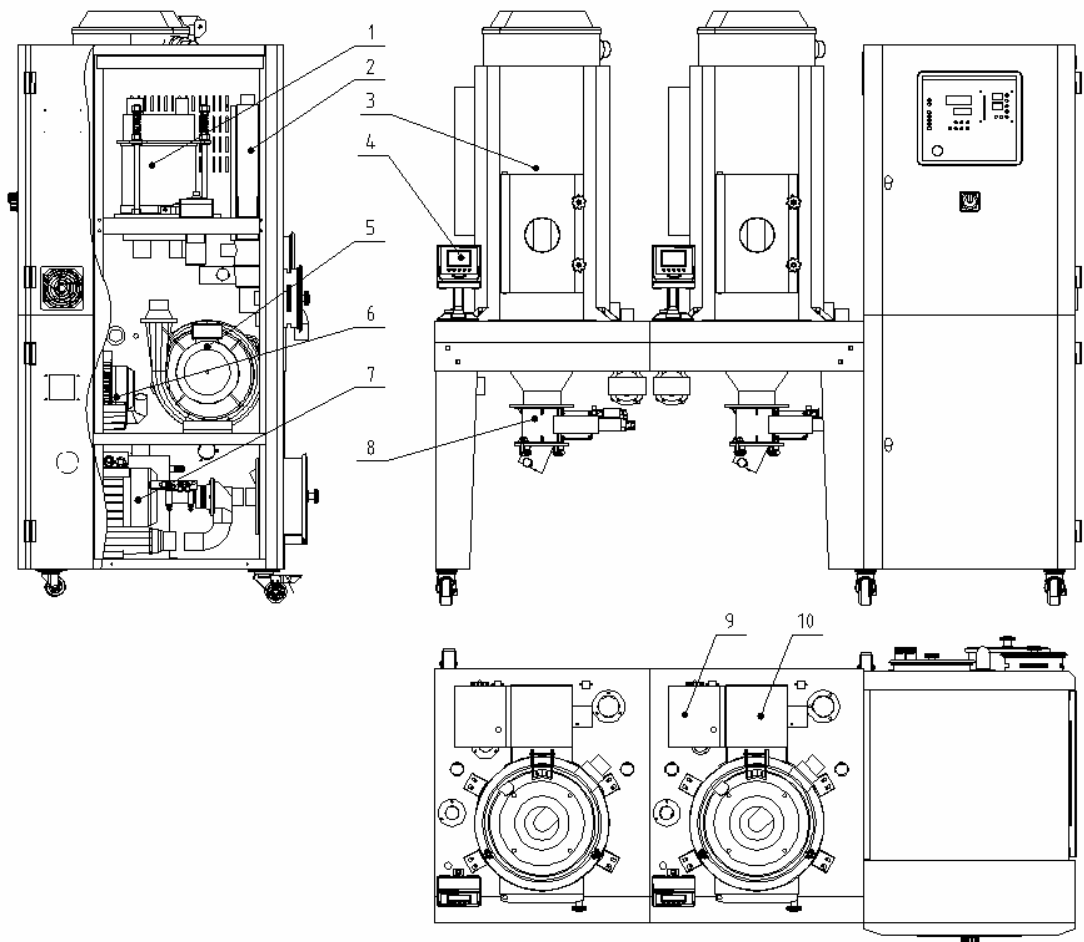

Names of Parts:

- 1. Honeycomb-rotor 2. Regenerating heater 3. Drying hopper 4. Control box
- 5. Drying blower 6. Regenerating blower 7. Conveying blower
- 8. Shut-off Suction Box 9. Control cabinet 10. Drying heater heating case

Picture 2-2: Structural Drawing

2.3.2 Part drawing

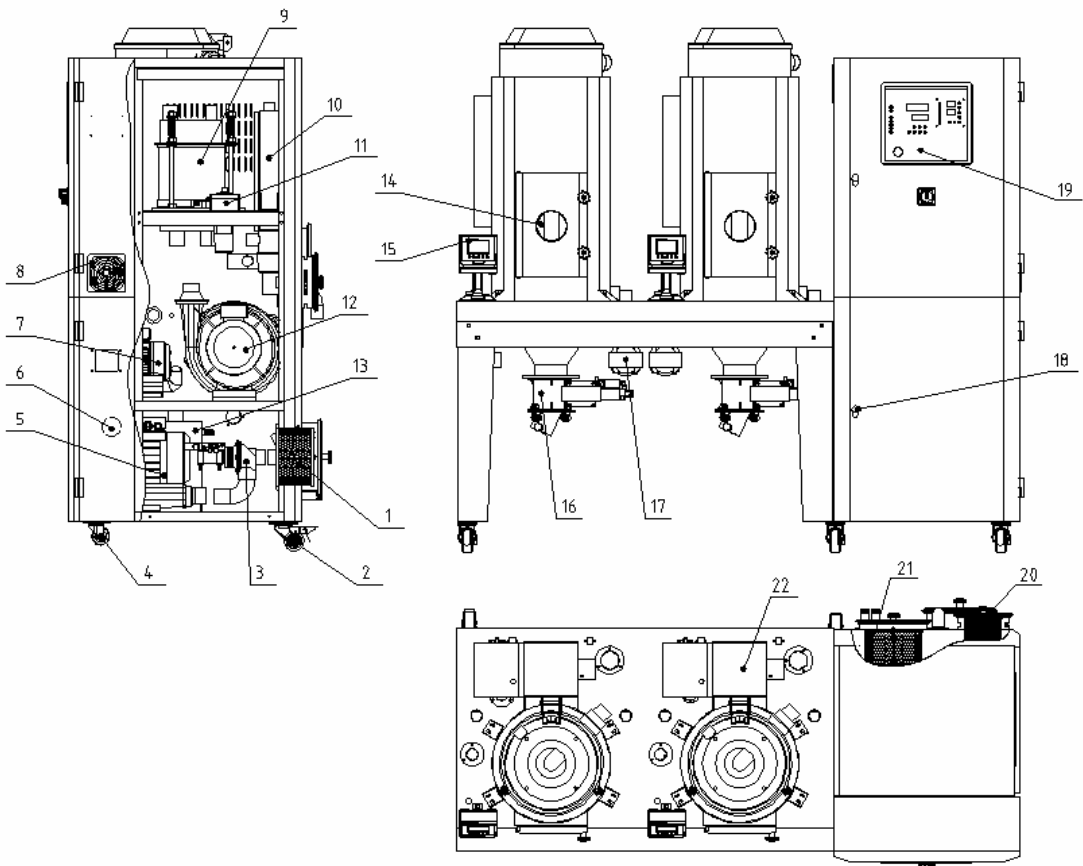

Remarks: Please refer to material list 2.5.3 for specific explanation of the Arabic numbers in parts drawing.

Picture 2-3: Assembly Drawing

2.3.3 Parts List

Table 2-1: Parts List

No.	Description	Part No.	No.	Description	Part No.
1	Feeding filter ** SAL-700/800G	YR50708000200	12	Drying blower *	YM30753200000
2	Black brake castor 3"	YW03000300000	13	Cooler	BW88080000020
3	Vacuum-break separating valve SVBV-38-24V	BY20003800100	14	Sight-glass	YW70102000000
4	Black brake castor 3"	YW03000300200	15	Control box	YR40400200000
5	Conveying filter *	BM30042000050	16	Shut-off valve type suction box *	BY10203800050
6	Thermometer	YE85030000000	17	Vacuum-break separating valve SPDV-38(24VDC)	BY20382400050
7	Regen. blower *	BM30020500050	18	Door lock	YW00816100000
8	Exhaust fan	YM60121200400	19	Plastic panel	BH10008001710
9	Honeycomb assembly *	Refer to 2.4.5	20	Regen.filter **	YR50128300100
10	Regen. heater **	BH70150400050	21	Circulation filter **	YR50128300100
11	EGO	BH90115000050	22	Drying heater **	BH70803900250

* means possible broken parts.

** means easy broken part. and spare backup is suggested.

Please confirm the version of manual before placing the purchase order to guarantee that the item number of the spare part is in accordance with the real object.

2.3.4 Honeycomb Assembly

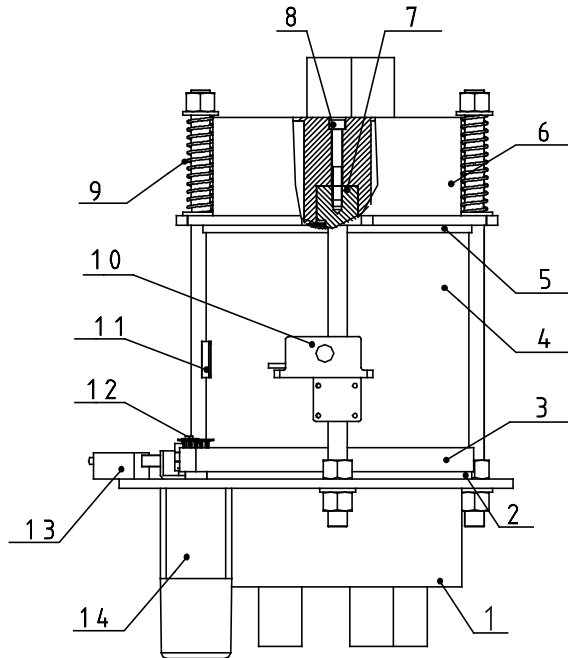

Table 2-2: Parts list of honeycomb assembly

No.	Description	Part No.	No.	Description	Part No.
1	Rotor bottom cover	-	8	Inner hexagon cylindrical screw M8*65	YW61086500000
2	Silica gel Teflon upper pad	YR10010000900	9	Spring	YW01201800000
3	Synchronous belt 20x300XL	YR00203000000	10	Microswitch LXW5-1124	YE14152400000
4	Honeycomb $\varnothing 220 \times 200L^*$	YW71022000000	11	Honeycomb stator	YR00202500000
5	Silica gel Teflon lower pad	YR10010000700	12	Synchronous belt pulley	YW08001000100
6	Honeycomb upper cover	-	13	Belt tension regulator	-
7	Honeycomb installed shaft	BH10005003110	14	Gearmotor	YM50212000000

Please confirm the version of manual before placing the purchase order to guarantee that the item number of the spare part is in accordance with the real object.

Table 2-5: Parts list of heater assembly

2.4 Electrical Diagram

2.4.1 Main Circuit

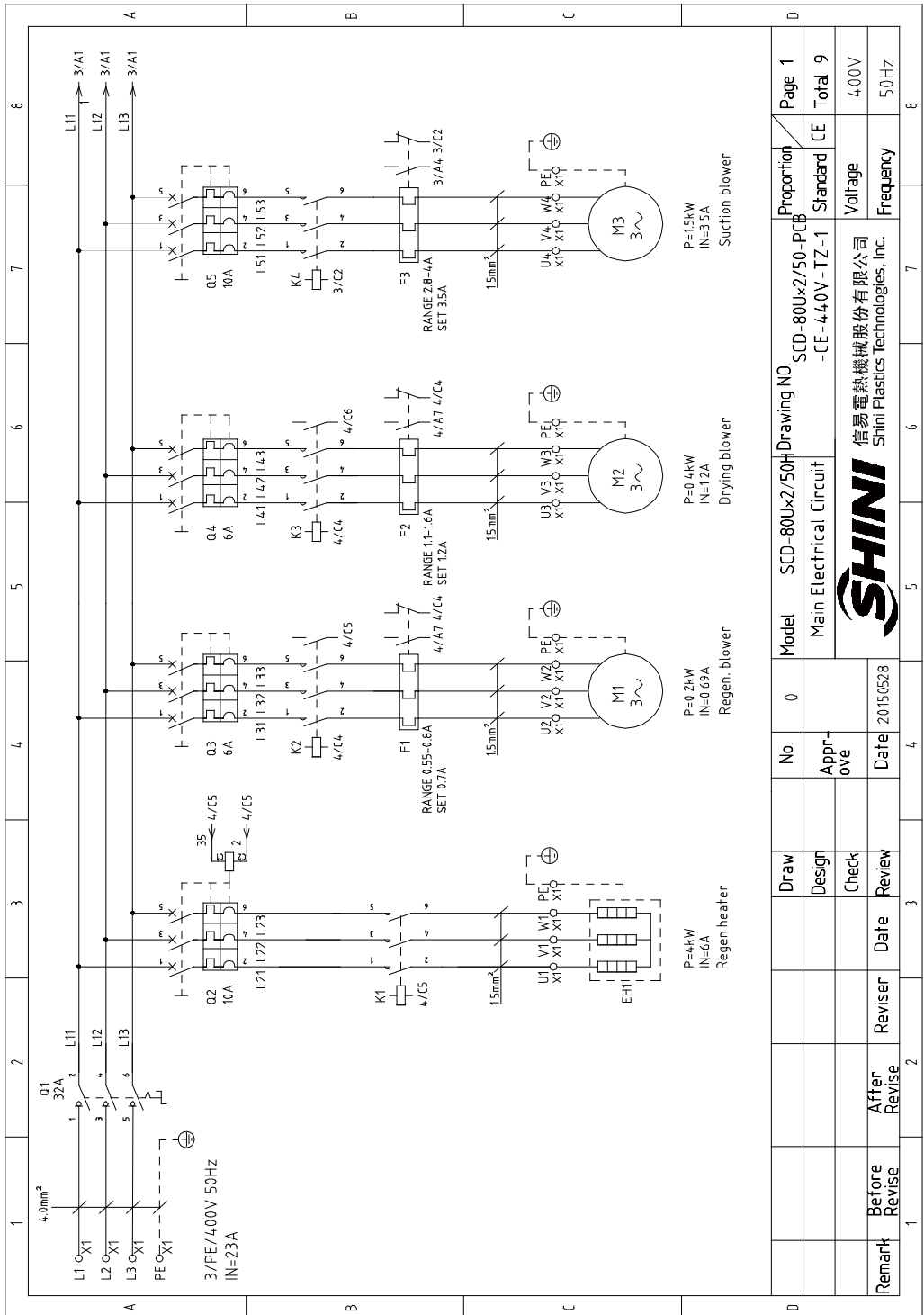

Proportion		Page 1	
Standard	CE	Total	9
Voltage		4.00V	
Frequency		50Hz	

Model	SCD-80Ux2/50-PCB	Drawing NO	SCD-80Ux2/50-PCB
Main Electrical Circuit		-CE-440V-TZ-1	
No.	0	Date	2015/05/28
Draw	Design	Reviser	After Revise
Design	Check	Date	
Check	Review		
Review			

Remark	Before Revise	After Revise	
--------	---------------	--------------	--

Picture 2-4: Main Circuit 1

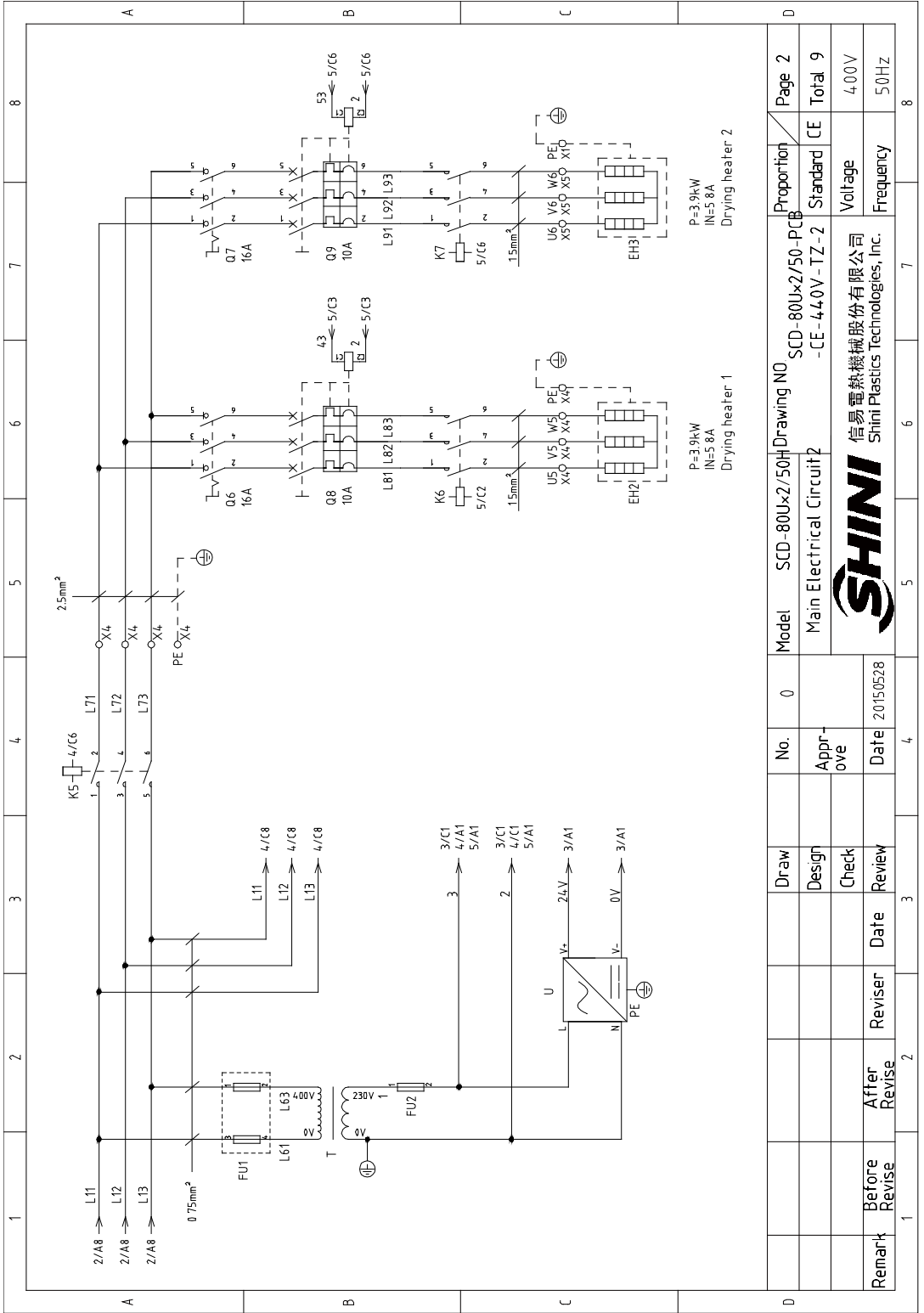

Picture 2-5: Circuit 2

2.4.2 Control Circuit

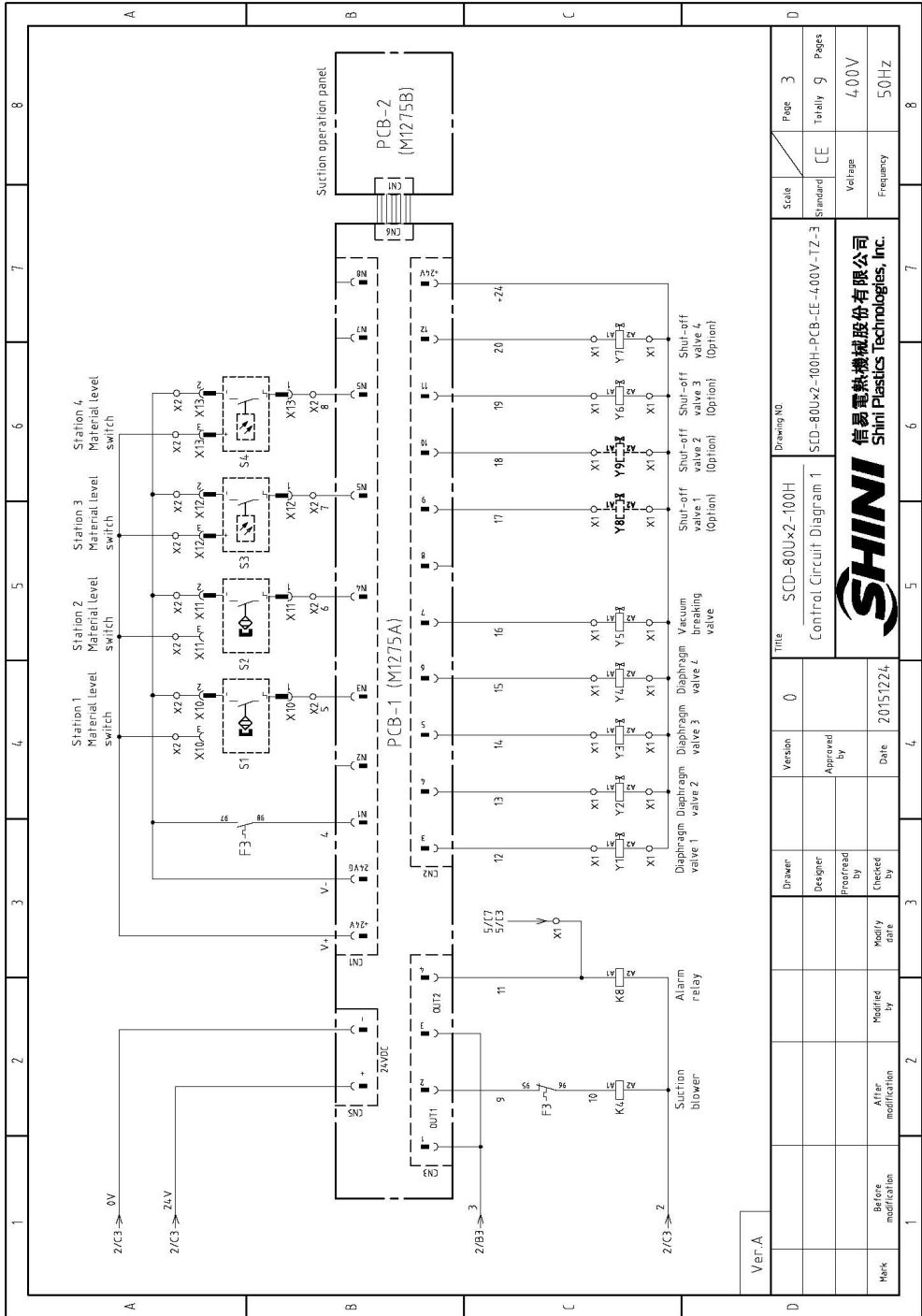

Picture 2-6: Control Circuit 1

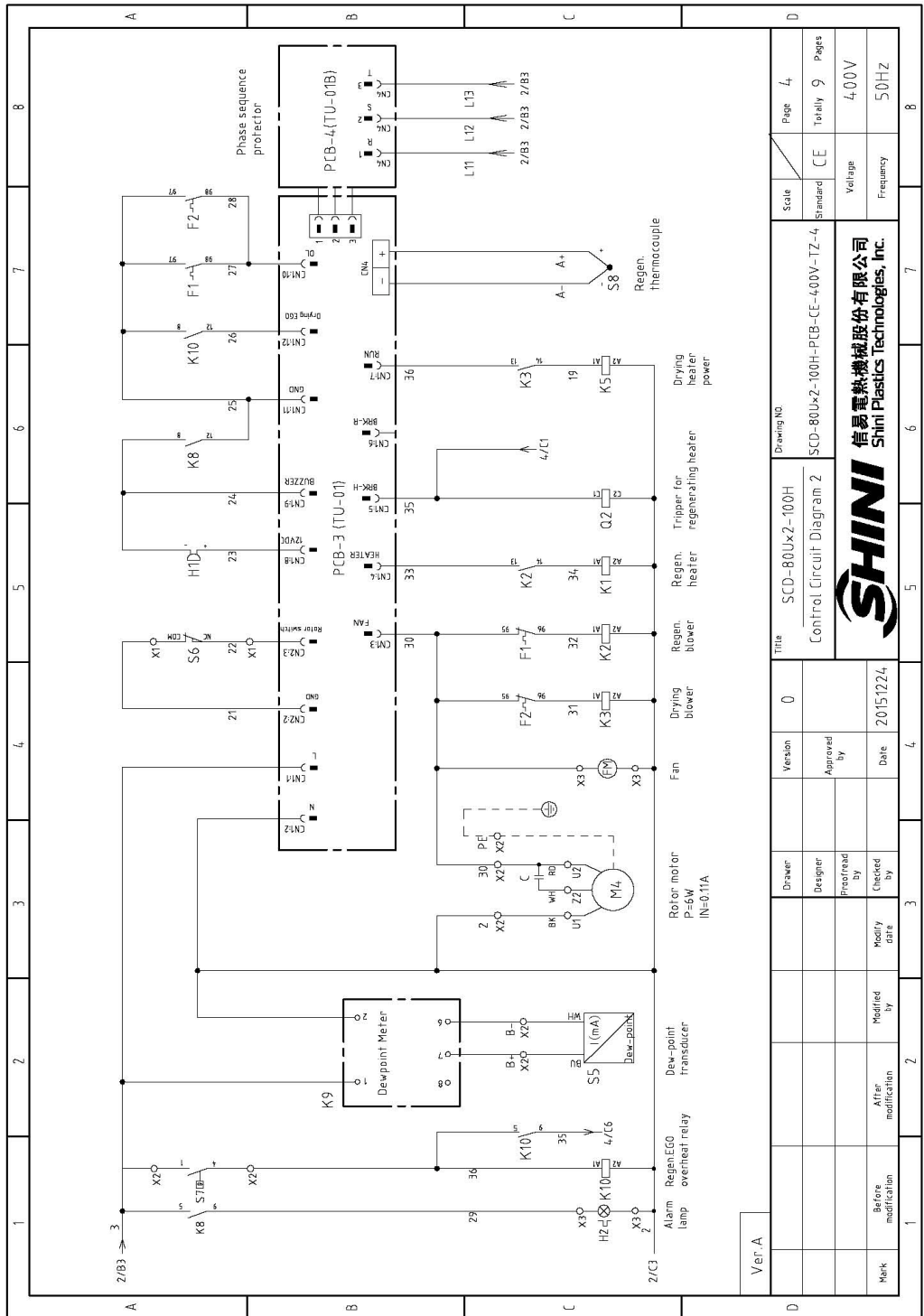

Picture 2-7: Control Circuit 2

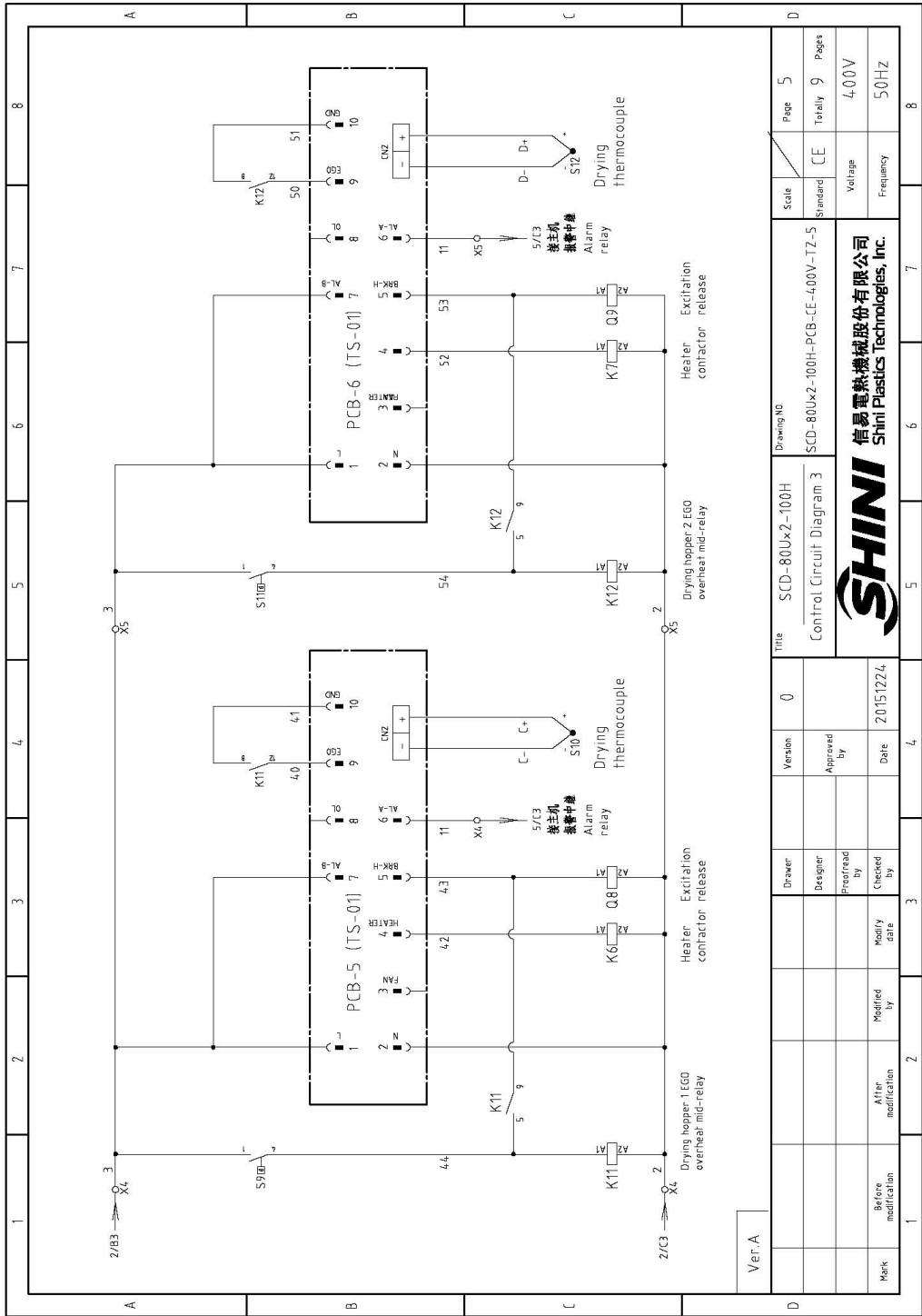

Picture 2-8: Control Circuit 3

2.4.3 Components Layout

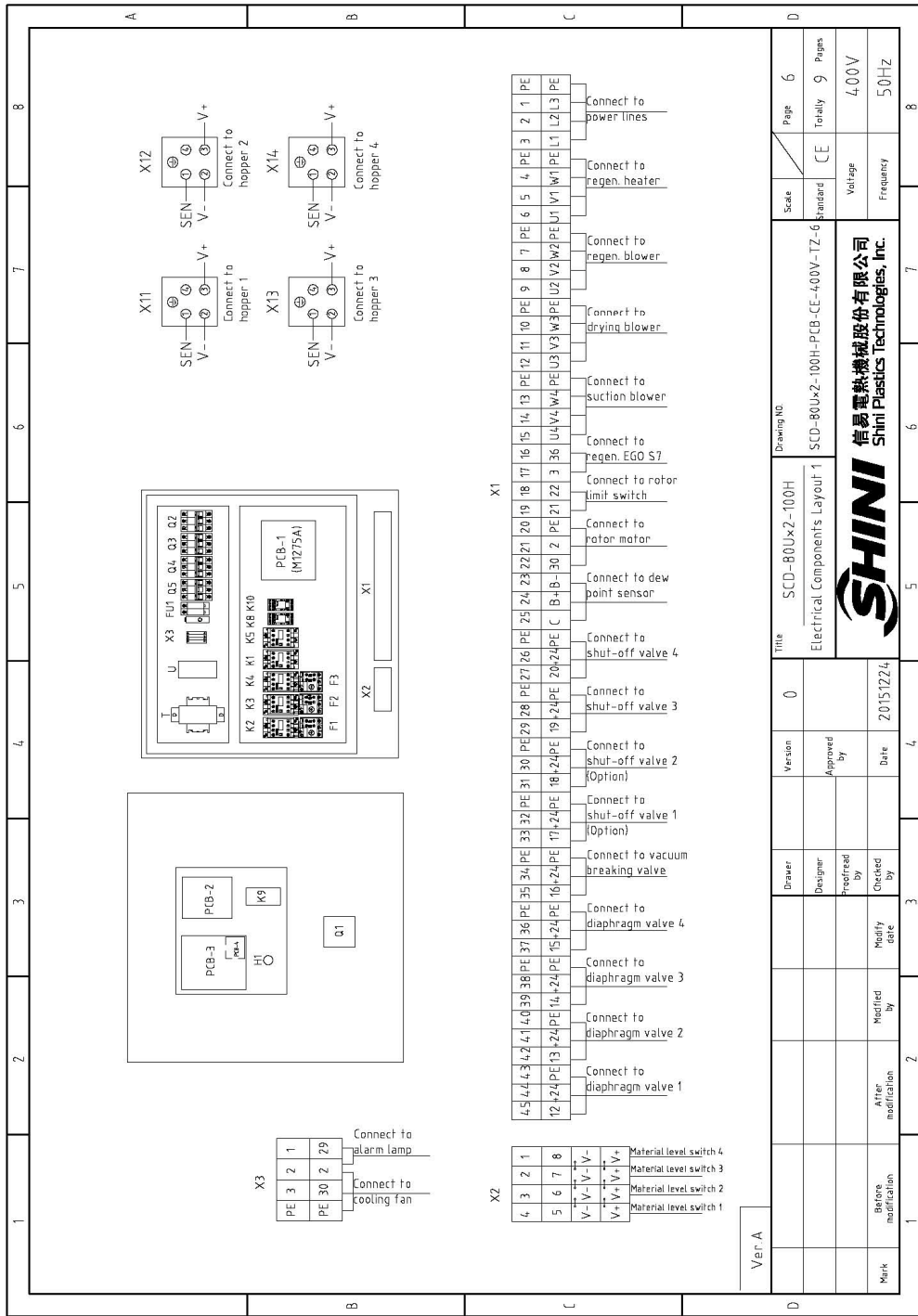

Picture 2-9: Components Layout 1

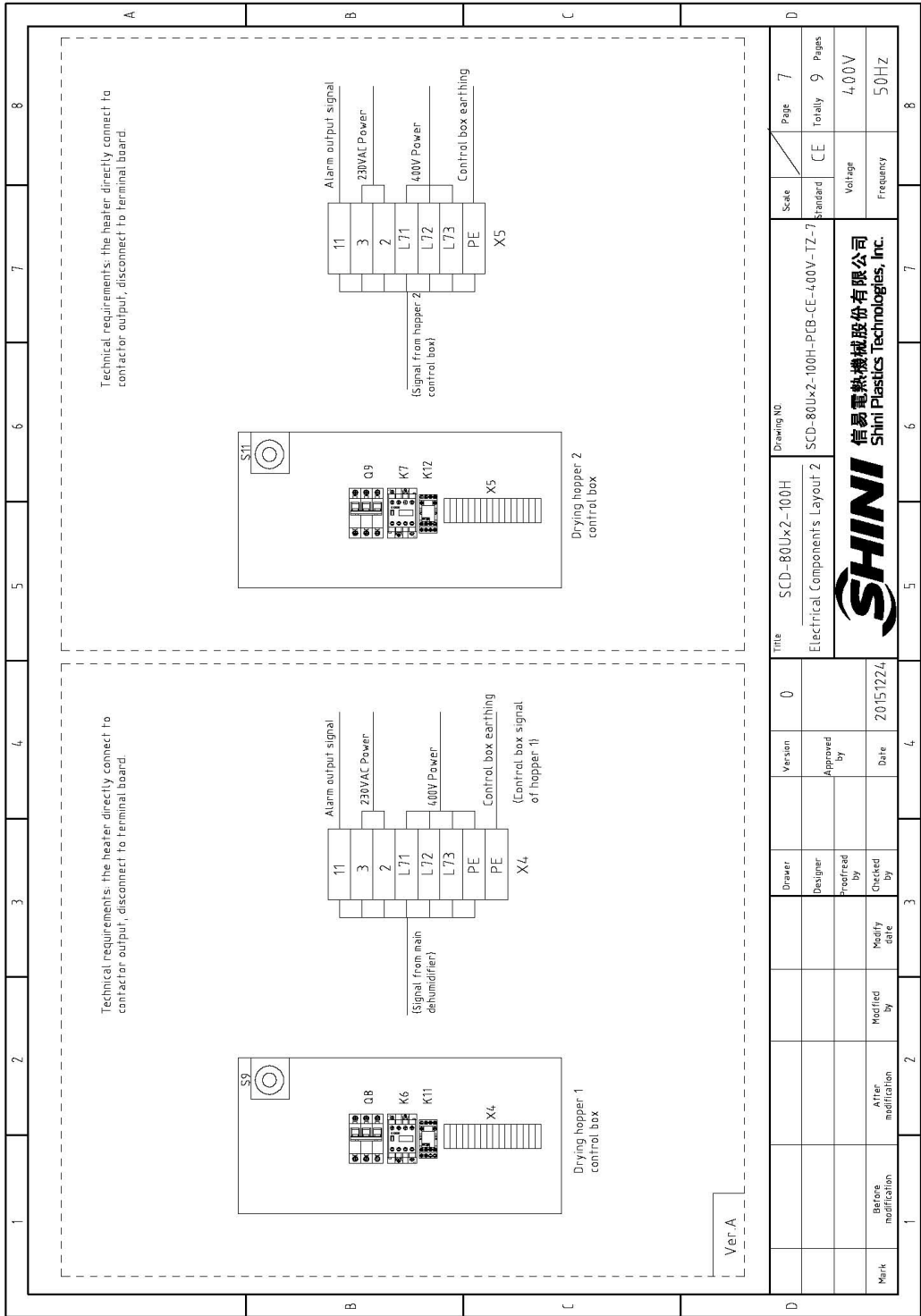

Picture 2-10: Components Layout 2

2.4.4 Electrical Components List

Table 2-3: Electrical Components List 1

1		2		3		4		5		6		7		8	
NO	Symbol	Name	Manufacturer	Type	Specification	Number	Material number	Remark							
1	Q1	Main switch	SIEMENS	3LDZ203-0TK53	3ZA	1	YE10220300000								
2	Q2 Q5 Q8 Q9	Circuit breaker	TECO	BM-63C/3010S	10A	4	YE40301003000								
3		Tripper	CHINT	MX	----	3	YE40023560000								
4	Q3 Q4	Circuit breaker	TECO	BM-63C/3006S	6A	2	YE40300603000								
5	Q6 Q7	Main switch	SIEMENS	3LDZ203-0TK53/16A	16A	2	YE10203000000								
6	K1 K6 K7	Contactors	SIEMENS	3RT6016-1AN21	220V 50/60Hz	3	YE00601621000								
7	K2 K3 K4	Contactors	SIEMENS	3RT6015-1AN21	220V 50/60Hz	3	YE00601521000								
8	K5	Contactors	SIEMENS	3RT6018-1AN21	220V 50/60Hz	1	YE00601800000								
9	K8 K10 K11 K12	Middle relay	WEIDMULLER	DRM270730LT	230V 50/60Hz	4	YE03270700000								
10	K9	Dew-point meter	SHINI	Dewpoint Merler	220V 50/60Hz	1	YE85122000100	(2)							
11	F1	Thermo overload relays	SIEMENS	3RU6116-01B0	0.55-0.8A	1	YE01161550000								
12	F2	Thermo overload relays	SIEMENS	3RU6116-1AB0	1.1-1.6A	1	YE01160110000								
13	F3	Thermo overload relays	SIEMENS	3RU6116-1E30	2.8-4A	1	YE01160280000								
14	FU1	Fuse**	CHINT	CHINT/32A/2P	32A/2P	1	YE41032200000								
15	FU2	Fuse core	MRO	MRO/2A 500V	2A	2	YE46002000100								
16	FU3	Fuse**	YINDA	FS-10	2A	1	YE41001000000								
17	T	Transformer**	BAIYUN	IN=400V OUT=230V	1000mA	1	YE70402300000								
18	U	DC Power	MEAN WELL	S-35-24	OUT=DC24V 15A	1	YE773524-00000								
19	PCB-1 (PCB-2)	PCB	HONGYUN	M1275	24VDC	1	YE80127500000								
20	PCB-3	PCB	YUYUN	TU-01A	220VAC	1	YE80001100000								
21	PCB-4	PCB	YUYUN	TU-01B	-----	1	YE80001100100								
22	PCB-5 PCB-6	PCB	YUYUN	TS-01	220VAC	2	YE80000100300								
23	S5	Dew-point transducer	C5	217-0EM	POWER=24VDC 4--20mA	1	YE90021700100	(1) (2)							
24	S6	Micro switch	----	----	----	1	----	(1)							
25	S7 S9 S11	Temperature protector	----	----	----	3	----	(1)							
Ver. A (Notes: (1)Means it's not the material inside the control box. (2)Stands for optional. /means possible broken parts. **means easy broken part. and spare backup is suggested.															
D		Title		SCD-80UxZ-100H		Scale		Page 8		Standard		CE		Page 8	
		Drawing No		SCD-80UxZ-100H-PCB-CE-4.00V-TZ-8		Voltage		4.00V		Frequency		5.0Hz		Page 9	
Mark		Before modification		After modification		Modified by		Healy date		Date		20151224			
		Designer		Version		0		Approved by		SHINI		Shini Plastics Technologies, Inc.			

Table 2-4: Electrical Components List 2

1		2		3		4		5		6		7		8	
NO.	Symbol	Name	Manufacturer	K TYPE	Type	Specification	Number	Material number	Remark						
26	S8 S10 S12	Thermocouple	SHINI			----	3	----	(1)						
27	H1	Buzzer	HITPOINT	PK-27A		24VDC	1	YE64002700000	(1)						
28	H2	Alarm indicate	SHINI	LTE-3051		220V 50/60Hz	1	YE83305100300	(1)						
29	Y1-Y7	Solenoid valve	----	----		24VDC	7	----	(1)						
30	Y8 Y9	Solenoid valve	----	----		24VDC	2	----	(1) (2)						
31	X1	Terminal board	----	4mm ²		----	3	YE61040000000							
32		Terminal board	----	4mm ² PE		----	1	YE61043500000							
33		Terminal board	----	2.5mm ²		----	42	YE61250040000							
34		Terminal board	----	2.5mm ² PE		----	1	YE61253500000							
35	X2	Terminal board	----	ZDIK 1.5		10A 250V	4	YE60001500000							
36			----	FBSTB 10-ZDIK RD		10A 250V	4	YE60001000200							
37			----	FBSTB 10-ZDIK BU		10A 250V	4	YE60001000000							
38	X3	Terminal board	----	2.5mm ²		----	3	YE61250040000							
39			----	2.5mm ² PE		----	1	YE61253500000							
40	X4	Terminal board	----	2.5mm ²		----	6	YE61250040000							
41			----	2.5mm ² PE		----	2	YE61253500000							
42	X5	Terminal board	----	2.5mm ²		----	6	YE61250040000							
43			----	2.5mm ² PE		----	1	YE61253500000							
44	X10,X11,X12,X13	Heavy duty connector	SIBAS	HDL-HA-004.1		4P 10A	4	YE68041000100	(1)						
45	FM	Fan	----	----		230V 50/60Hz	1	YM60127200400	(1)						
46	M1	Drying blower	SHINI	----		400V 50Hz 0.4kW	1	----	(1)						
47	M2	Regen. blower	SHINI	----		400V 50Hz 0.2kW	1	----	(1)						
48	M3	Suction blower	SHINI	----		400V 50Hz 1.5kW	1	----	(1)						
49	EH1	Heater*	SHINI	----		400V 50Hz 4.0KW	1	----	(1)						
50	EH2 EH3	Heater*	SHINI	----		400V 50Hz 3.9KW	2	----	(1)						

Ver-A Notes: (1)Means if's not the material inside the control box. (2)Stands for optional. /*means possible broken parts. *means easy broken part. and spare backup is suggested.									
D		Drawing NO		Title		Scale		Page	
		SCD-80Ux2-100H		SCD-80Ux2-100H-PCB-CE-400V-TZ-9		Standard		CE	
		Electrical Components List 2				Voltage		400V	
						Frequency		50Hz	
Mark		Before modification		After modification		Modify date		20151224	
		Designer		Approved by		Date		20151224	
		Checked by		Modify date					
		Totaly		Page		Totally		Page	
		4		9		4		9	

2.5 Options

2.5.1 Installation for Dewpoint Monitor, Add "D" at the end of the model code.



Picture 2-11: Hole Site

- 2) Check if there are complete parts for dewpoint monitor including:
 - Dew-point monitor
 - Dew-point transmitter assembly (dew-point detector, detection cable, washer and installation guide)
 - Copper joint, installation seat for dew-point monitor



Picture 2-12: Parts of Dew-point Monitor

- 3) Remove the dew-point detector assembly from the machine, and mount it to another $\Phi 28$ hole on the controller. Install a dew-point monitor base on original hole, and mount two Teflon pipe connectors on the base. Via the copper pipe, one connector connects to the honeycomb and another connects to the dew-point detector assembly.



Picture 2-13: Copper Joint Assembly of Original Machine

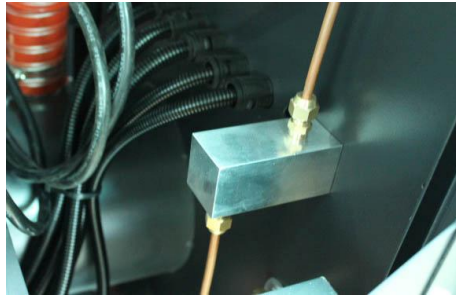

Picture 2-14: Installation Seat

4) Install dew-point transmitter assembly to copper joint.

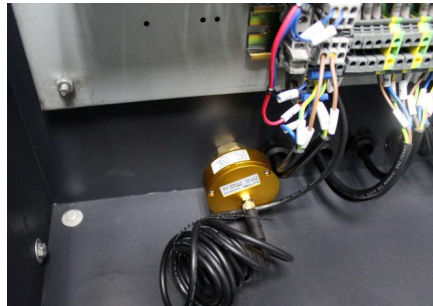

Picture 2-15: Installation for Transmitter

5) Insert the dew-point monitor into the hole on the panel and fasten it.

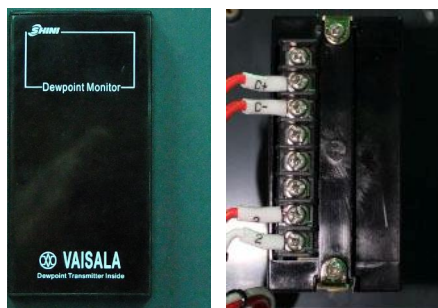

Picture 2-16: Connection of Signal Wire

6) Connect signal wires of the transmitter and power lines of dew-point monitor with the according terminals.

Connet contact No.1 and No.2 with power, supply is 220VAC.

Contact No.3, No.4 and No.5 are idle.

Connect contact No.6 and No.7 with the signal of transmitter. (C- Connects contact No.6, C+ connects contact No.7

Dew-point transducer wiring (white connects to C-, blue connects to C+)

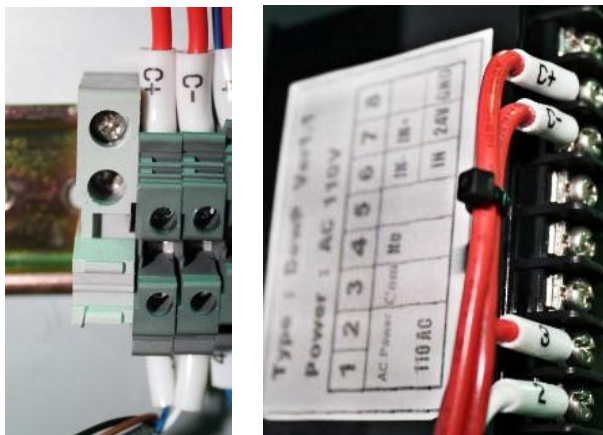

Picture 2-17: Connection of Dew-point Monitor

2.5.2 For models with hopper polished inside, add "P" at the end of the mode code.

2.5.3 For models optional with dew-point control, add "DC" at the end of the mode code.

2.5.4 Installation Testing



Before installation, please read through this chapter carefully. Install the machine according to following steps. The power connection should be completed by professional technicians!



Notes!

Keep 2m distance between the machine and the combustibles.

2.6 Machine Allocation

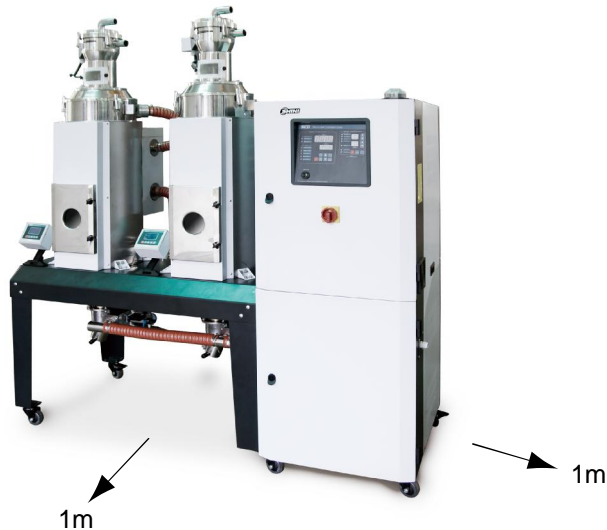

Picture 2-18: Installation Drawing

2.7 Duct and Feed Tube Connection

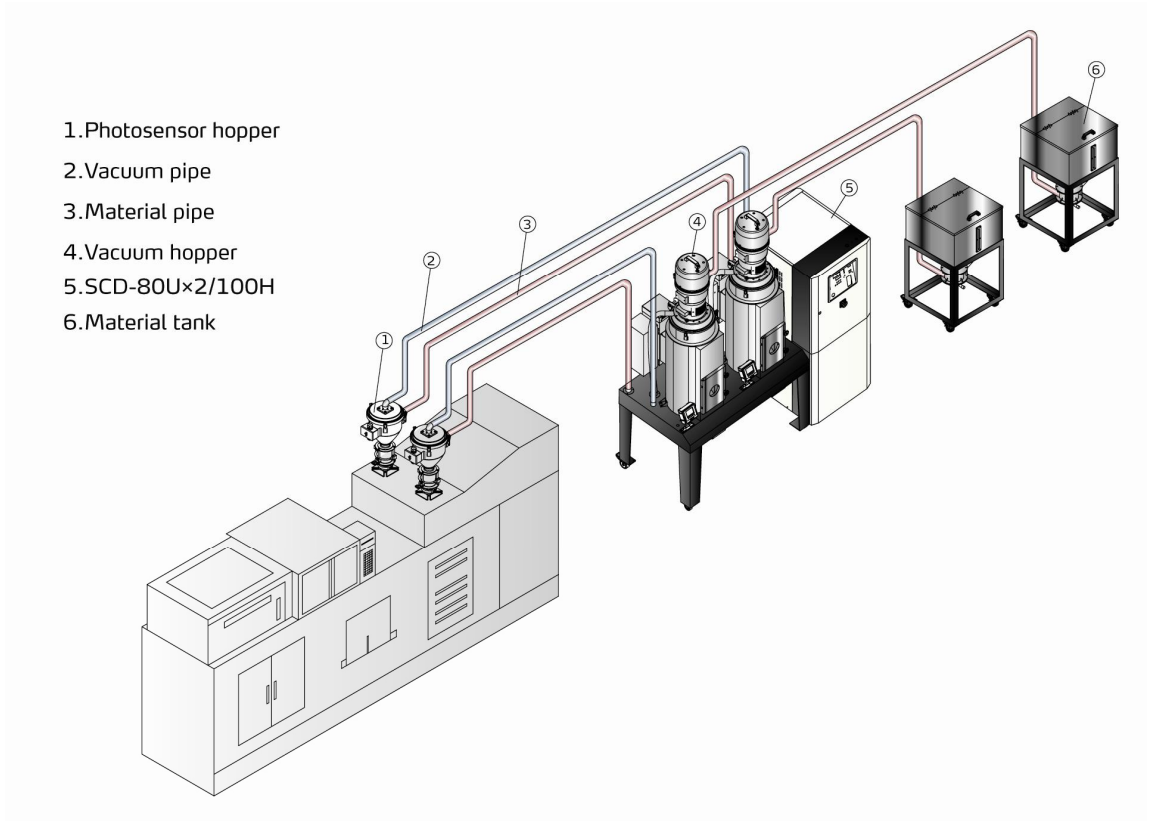

Picture 2-2: Installation Drawing

2.8 Water Connection

Cooling water pressure is $3\sim 5\text{kgf/cm}^2$, the water inlet & outlet pressure difference is $3\sim 5\text{kgf/cm}^2$ cooling water temperature is at $10\sim 30^\circ\text{C}$.

	<p>Water outlet: cooling water outlet.</p>
	<p>Water inlet: inlet for replenishing water and cooling water.</p>

2.9 Air Supply Connection

Quality grade: 335 (solid particle concentration $\leq 5\text{mg/m}^3$, dew-point temperature is about -20°C , oil content $\leq 25\text{mg/m}^3$)

Air pressure: 3~5bar

Air quantity: about 10L/hr

Pipe dimension: PM20

2.10 Electrical Connections

- 1) Make sure voltage and frequency of the power source comply with those indicated on the manufacturer nameplate, attached to the machine.
- 2) Power cable and earth connections should conform with your local regulations.
- 3) Use independent electrical wires and power switch. Diameter of electrical wire should not be less than those used in the control box.
- 4) The power cable connection terminals should be tightened securely.
- 5) The machine requires a 3-phase 4-wire power source, connect the power lead (L1, L2, L3) to the live wires, and the earth (PE) to the ground.
- 6) Power supply requirements:
 - Main power voltage: +/- 10%
 - Main power frequency: +/- 2%
- 7) Refer to the electrical wiring diagram to complete the electrical Installation.

3. Application and Operation

Turn on the main switch to connect power supply on the control panel.

3.1 Dehumidifying System Operation

- 1) Open the main switch.
- 2) Press "RUN/STOP" key to start dehumidifying working.

3.2 Temperature Setup

- 1) The setup number will flicker after pressing "SET" key, add or decrease temperature by pressing ▲ ▼ key.
- 2) Press "ENTER" key to confirm the input value.

3.3 PID Auto-tuning Setting

- 1) Press "SET" and the digits flash. At this time press "SET" and "Enter" meanwhile for 1.5 seconds to enter auto-tuning mode. Then two values of "At" and "Present temperature" will display alternatively in PV and the set temperature value displays in SV till auto-tuning is finished. After that, system goes back to the normal operation directly.
- 2) If auto-tuning setting could not be finished within 1 hour, the parameters will not be altered and system goes back to normal operation.
- 3) Pressing "ON/OFF" to go back normal operation amid automatic calculation would not alter the original parameters.

Note: Before delivery, PID parameter has been already set. Don't process the PID auto-tuning function unless it is necessary.

3.4 Intermittent Running Setup

Drying periods(0-ON)  Stop periods (0-OFF)

- 1) Press "SET" key to enter setting mode, press "TEMP/TIMER" key, the temperature set value switches to time set value. In this time, "SV/set value" flickers, and "PV/ set value" displays "0-ON".



Picture 3-1: Intermittent running setup 1

- 2) PV displays "0-ON" to stand for drying periods. "0-OFF" stands for machine stop time. Press ▲▼ key to add or decrease time value of "SV/setup value". Each press of ▲▼ can add or decrease 15 mins set time.
- 3) Press "ENTER" to confirm the input time value and enter into "0-OFF" time setup items, then repeat step 2.



Picture 3-2: Intermittent running setup 2

Note: If set 0-ON as 04:00, 0-OFF as 05:00, which means drying periods is 4 hours stop time is 5 hours, then working for 4 hours and being stopped for 5 hours and repeat this so long.

- 4) Cancel intermittent running by entering 00.00 at "0-ON" or "0-OFF" press "ENTER" to confirm input value after time setup and enter into time setup items from "1-ON" "week-ON".



Picture 3-3: Intermittent running setup 3

3.5 Weekly Time Start Setup

- 1) Press ▲▼ key to add or decrease the time value in "SV/setup value" of "1-ON". Press "ENTER" to confirm the input value and comes into the time setup items of "1-OFF" "MON-OFF".

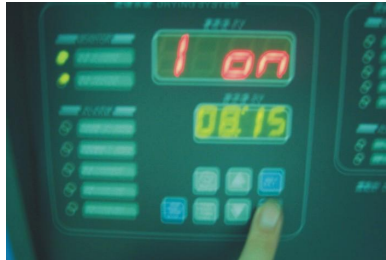

Picture 3-4: Weekly Time Start Setup 1

- 2) Press ▲▼ key to add or decrease the time value in "SV/setup value" of "1-OFF" . Press "ENTER" to confirm the input value and comes into the time setup items of "2-ON""TUE-ON".



Picture 3-5: Weekly Time Start Setup 2

- 3) Do the same setup again and again to setup the ON/OFF time from Monday to Sunday.



Picture 3-6: Weekly Time Start Setup 3

- 4) Press "SET" key to back to normal status, after finish all the setup.
- 5) Setup all the "ON" to 00:00 if it is not for time start/stop.

3.6 Present Time Modification

- 1) After 7-OFF setting is finished, press“ENTER”key, it displays“TIME”that is the present time.

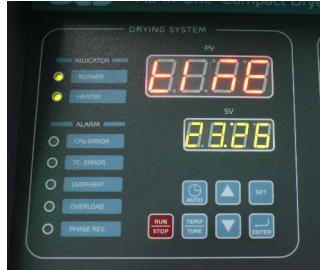

Picture 3-7: Present Time Setup

- 2) Press ▲▼key to increase and decrease the time.
- 3) Press“ENTER”key, PV displays“DAY”that is the day in a week.

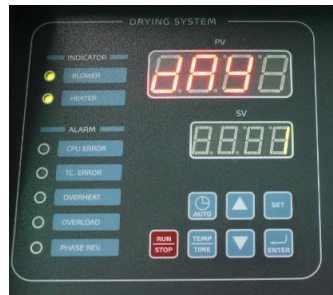

Picture 3-8: Weekly Day Setup

- 4) Press ▲▼ key to increase and decrease the day, press“ENTER”to confirm.
- 5) After the setting is finished, press“SET”key to return the normal mode.

3.7 Weekly Time Start/Stop

- 1) Activate the weekly time start after finish the time setup and the present time setup.
- 2) Press "AUTO" key at working or stop status to preset the time start/stop, the "PV" will display the time and temp. alternatively.
- 3) Press "AUTO" again if want to cancel that weekly time setup.

3.8 Temperature Unit Selection

- 1) Hold on“SET”till“PV”displays F-20, F-20 works mainly as a password lock.

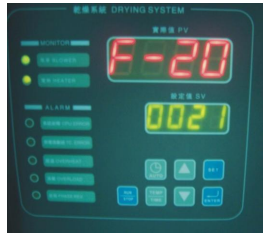

Picture 3-9: Temp. Unit Selection 1

- 2) Press ▲▼ key, input 0021 at SV, then press“ENTER”to select F-03 temp. unit.



Picture 3-10: Temp. Unit Selection 2

- 3) Press ▲▼key to switch between °C/°F , after the selection press “ENTER” to confirm.

3.9 Lock Setup

- 1) After F-03 setting is finished, press "ENTER" key. At the time, PV displays F-04.



Picture 3-11: Data Lock Screen

- 2) F-04 is a LOCK function, press ▲▼ key to select LOCK or OFF function.
- 3) After selection, press“ENTER”key to confirm; press“SET”key, do not save the value then exit.
- 4) When selects LOCK, press“SET”key during temp. setup, the SV would display “LOCK”.
- 5) Default value is OFF.

3.10 Low-temp. Alarm Setup

- 1) When machine starts up, the low-temp. alarm function doesn't work until it gets to set alarm temperature.
- 2) During normal operation, if temperature long time lowers than the alarm value and reaches alarm reaction time, low-temp. alarm would sound.
- 3) Low-temp. alarm value is a relative value.

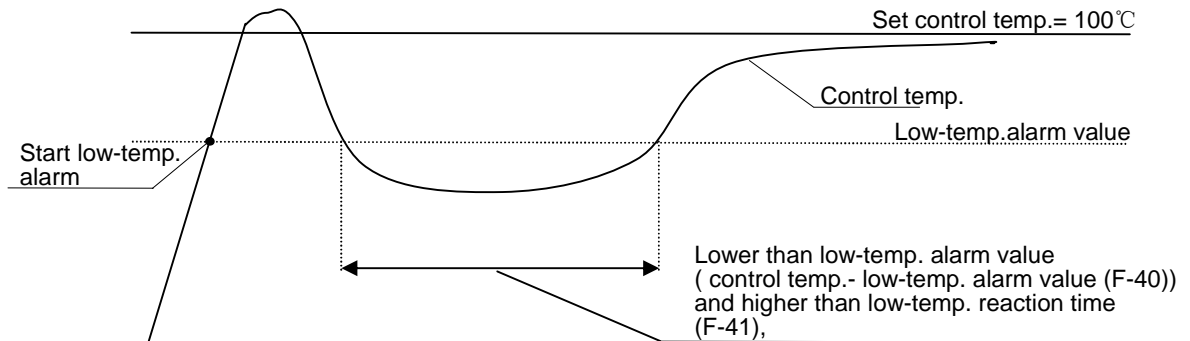

3.10.1 The Value of Low-temp. Alarm

- 1) After F-05 setting is finished, press“ENTER”key, at this time PV displays F-40.



Picture 3-12: Value of Low-temp. Alarm

Note: F-05 is to set over-temp. alarm, the default value is 15°C. It is not allowed to modify the value.

- 2) F-40 is to set low-temp. alarm, press key to modify the value of low-temp. alarm.
- 3) After the setting, press“ENTER”key to confirm, press“SET”key, do not save the value then exit.
- 4) The default value is 20°C.

3.10.2 Reaction Time of Low-temp. Alarm

- 1) After F-40 setting is finished, press“ENTER”key, at this time, PV displays F-41.



Picture 3-13: Reaction Time of Low-temp. Alarm

- 2) F-41 is the reaction time of low-temp. alarm, press ▲▼ key to modify the reaction time and start it. When the reaction time is OFF, low-temp. alarm function is closed.
- 3) The default value is OFF.

3.11 Heater Alarm

- 1) After F-41 setting is finished, press“ENTER”key, at this time, PV displays F-42.

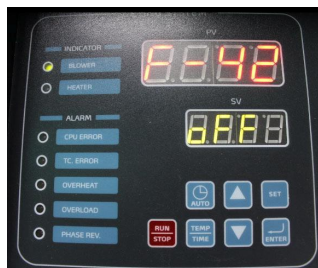

Picture 3-14: Heater Alarm

- 2) F-42 is heater alarm, press ▲▼ key to modify the alarm time and start it. When heater alarm is OFF, heater alarm function is closed. When it works, if the heater doesn't below the set temperature minus 5°C within alarm set time, the alarm would sound. If temperature is set as 100°C, alarm time is 30min, after heater starts, the temperature doesn't get to 95°C within the first 30min, the alarm would sound.
- 3) The default value is OFF.

3.12 Low-temp. Alarm

- 1): After it reaches the set temperature, system activates the low temperature alarm.
- 2): When control temp. is lower than abnormal temp. (control temp. – low temp. alarm value (F-40)) and higher than low temp. response time, system will sound alarm.
- 3): Even the system sounds alarm, the temperature control function is still working.

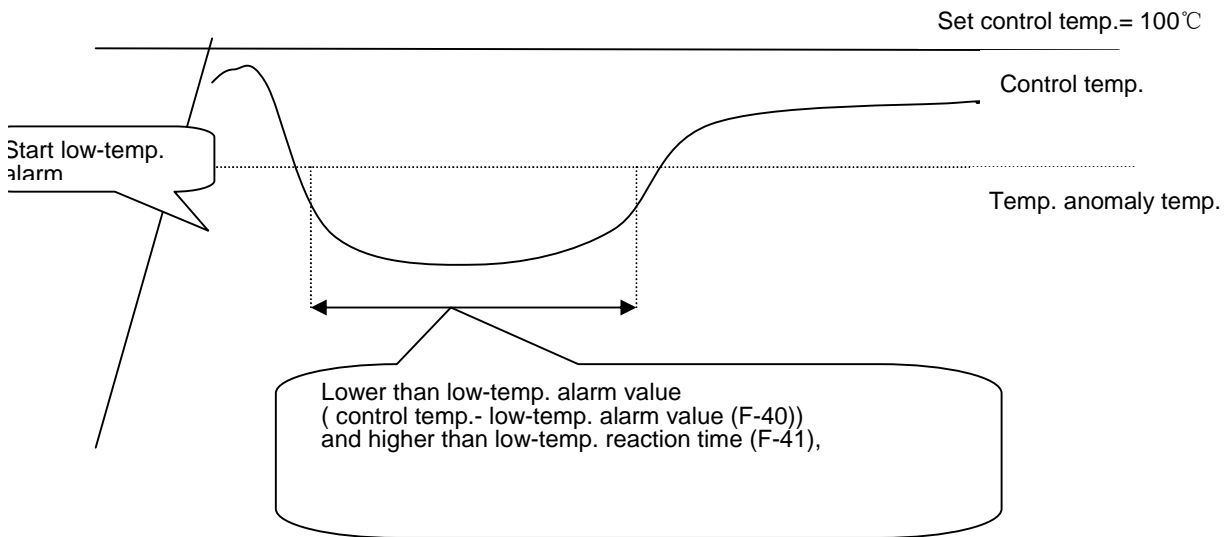

1.Parameter Setting Instruction

Code	Function	Range	Reset Value	Remarks
F-03	Temp. unit	℃, °F	℃	
F-04	Data lock	OFF, LOCK	OFF	LOCK is for data lock, it disables input data
F-05	Overheat protection temp.	0-100℃	20℃	Actual temp. > set temp. + overload protection temp., it sounds alarm
F-40	Low temp. alarm value	0-100℃	20℃	Actual temp. < set temp.-low temp. alarm value, it sounds alarm
F-41	Low temp. response time	OFF-99 Sec	OFF	When response time is OFF, low temp. alarm=OFF
F-42	Heater Alarm	OFF-99 Min	OFF	The temp. not reach set value in time unit

3.13 Alarm Description (Dehumidifying System)

Table 3-1: Parameter Table of Error Code

Error Code	Description
E-01	Heater thermocouple
E-02	Anti- phase, default phase
E-03	Blower overload
E-04	Drying temp. is higher than EGO protection set value
E-05	Drying temp. is higher than system set max. temp.
E-07	Over-temp protection ($PV \geq SV +$ set value, system sounds alarm)
E-08	Memory error
E-09	Honeycomb rotor fault
E-10	Regenerative temp. is higher than EGO protection set value.
E-11	Thermocouple of "+,-"connect wrongly.
E-12	PID auto-turning fault
E-13	Low temp. alarm
E-12	Heater Alarm

3.14 Drying System Operation

3.15 Control Panel



图 3-1: Control Panel

3.15.1 Operation Step

- 1) Open the main power switch of control box.
- 2) Press “RUN/STOP” key, start drying process at first, the state indicator is green;
- 3) Press “RUN/STOP” key once again, stop drying process, the state indicator is yellow.

3.15.2 Temperature Setting

- 1) After pressing “SET” key, the figure flicks, meanwhile press “▲▼” to add or decrease temperature value.
- 2) After temperature setting, then press “set” key again to confirm the input value.

3.15.3 Temperature Lock Setting

- 1) After pressing the “Menu” key for 2 secs, it displays “TIME”.
- 2) Repeat to press “ ” Key, till it displays “LOCK”;
- 3) Press” SET” key, the letter flickers, at this time press “ ” c▲“ ”to▼elect “YES” (lock temp. value) or “No” (Not lock).
- 4) Press “set” key, and confirm the value.
- 5) Press “menu” key, it returns operation screen.

Note” When “LOCK” set as “YES”, temperature setting is locked, unable to modify.



3.15.4 PID Setting

- 1) Press “menu” and “ ” keys together for 3 secs., it displays “P”(proportional band);;



- 2) Press “SET” key, the value flickers, meanwhile press “ ” or “ ” keys to add or decrease the value.
- 3) Press “SET” key, and confirm the value.
- 4) Press “ ” in turn, it displays “I” (Integration time) and “D” (Differential time);
- 5) Repeat above step 2 and step 3, input and confirm the related parameter.
- 6) Press “menu” key, and return the running screen.

Note: the PID parameter value directly affects the temperature control accuracy, please adjust it carefully.

Parameter	Code	Default Value
Proportional	P	5

band		
Integration time	I	200
Differential time	D	30
Overheat alarm	OTP	15°C
Control cycle	HCLE	15
Blower delay	FDLY	180
Temp. unit	UNIT	°C

3.15.5 Intermittent Running Setup

- 1) Press “menu” key for 2 secs. to set current time and week. Press “▲” or “▼” key to set AUTO start/stop timer, initial running time of RONE setup, ROFF intermittent running OFF time , RON intermittent running ON time.

3.15.6 Weekly Time Start Setup

- 1) After present time set up, press “menu” key for 5 secs. ,and press “ ” and “ ” key to set OFF1(Mon. Off Time), OFF2(Tue. Off Time), OFF3 (Wed. Off Time). OFF4 (Thu. Off Time), OFF5(Fri. Off Time), OFF6(Sat. Off Time), and OFF7(Sun. Off Time) .
- 2) Press “menu” key for 7s, press “ ” or “ ”to set ON1(Mon. On Time), ON 2 (Tue. On Time), ON 3 (Wed. On Time), ON 4 (Thu. On Time), ON5 (Fri. On Time), ON6(Sat. On Time), ON7(Sun. On Time).

3.15.7 Communication Setup (Option)

- 1) Press “Menu” + “ ” keys together for 3 secs, it displays “PRO”(communication protocol) (Note: communication protocol set as Modbus RTU —“RTU”).



2) Press “ ” key, it enters “ID”(communication address) setting.

(Note: In the same system, the communication address of each controller should be only, without repeat. Basically: the communication address of hopper 1 set as 1, the communication address of hopper 2 set as 2, and so on;

3) Press “SET” key, the value flickers, at this time, press “ ▲ r ▼ ” to Add or decrease the value;

4) Press “SET” key, to confirm the input;

5) Press “ ”key, it display “Baud” and “PAR” options (as below picture);

6) Repeat step 3 and step 4, input and confirm the parameter;

7) Press “Menu” key, it returns running screen.

Communication Parameter	Communication Code	Default
Communication Protocol	PRO	RTU
Communication Address	Id	1 (according to actual setting)
Baud	Baud	19.2K
PAR	PAR	none
Data length	Data	8
Stop bit	Stop	1

3.15.8 Operation process

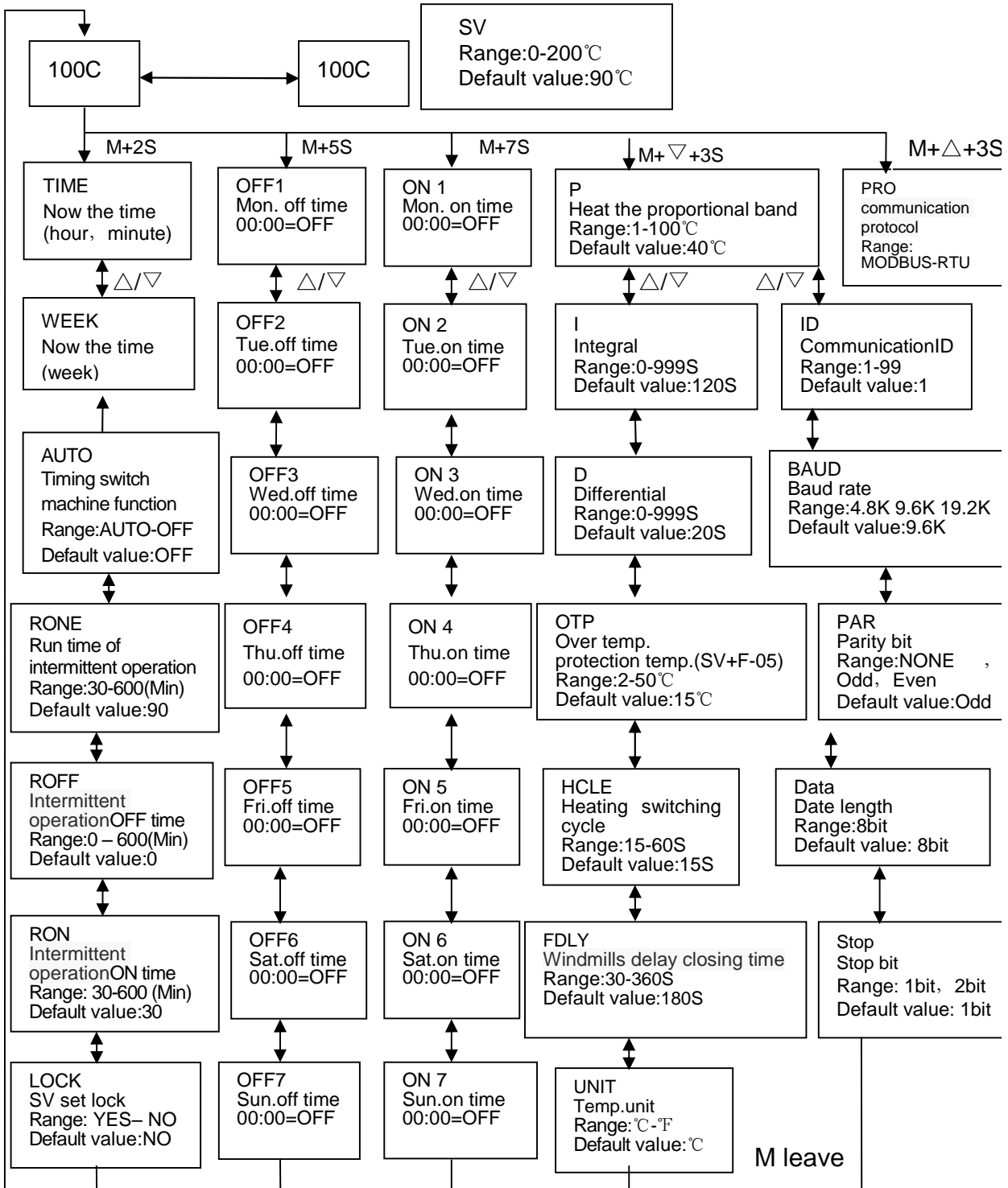

M express: Menu key

△/▽ express: Up/Down key

3.15.9 Error code description

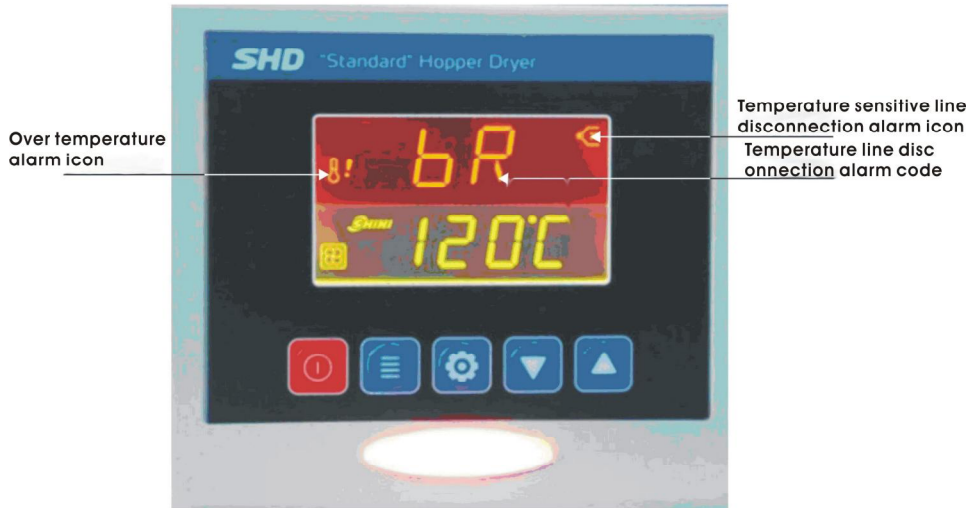

Error code	Explain
bR	Temp.sensitive line disconnection alarm
oH	Over temp.alarm
oL	Overload alarm
EGO	EGOOvertemperature electric power supply is cut off

3.15.10 Panel and Keys Instruction(Suction system)

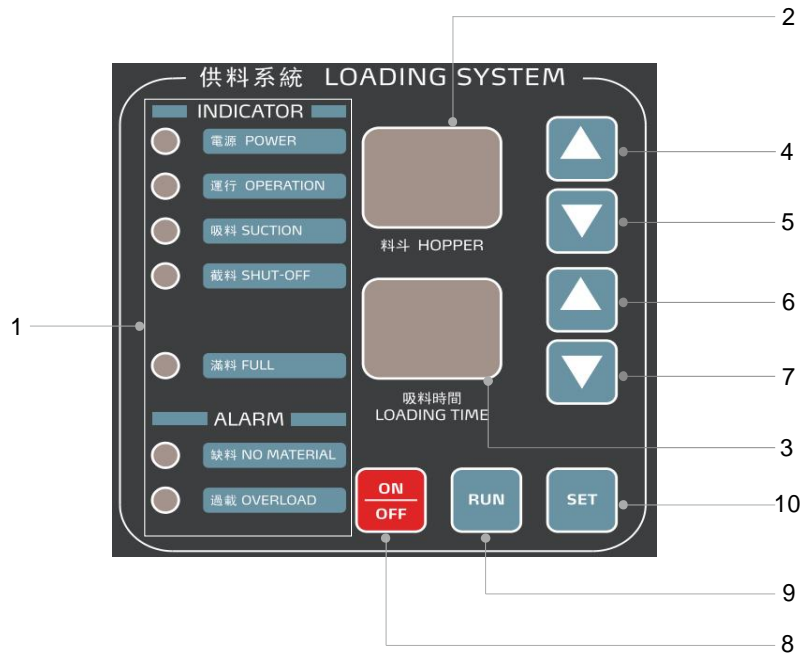

No.	Instruction
1	action indicating area
2	hopper displaying area
3	time setting area
4	hopper setting key (add up)
5	hopper setting key (lessen)
6	parameter setting key (add up)
7	parameter setting key (lessen)
8	ON/OFF key
9	RUN key
10	SET key

3.15.11 Machine Start/Stop

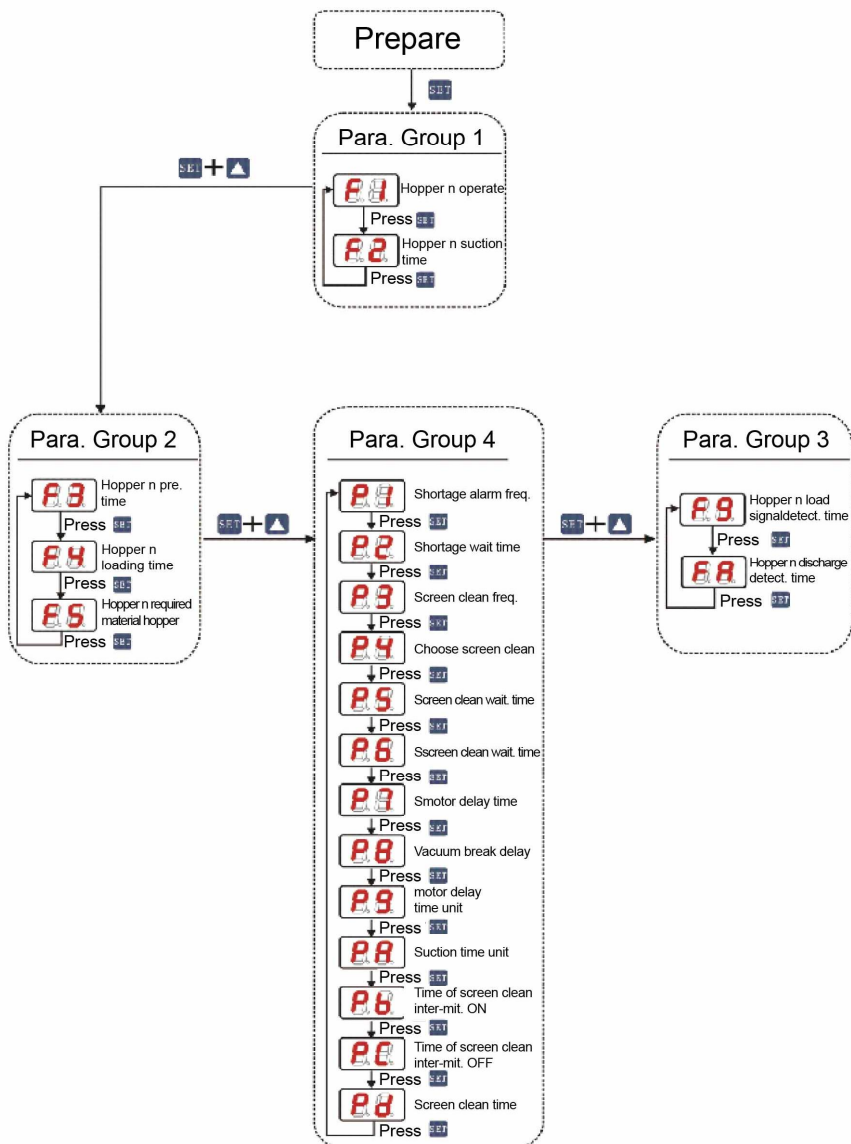

1. Power on machine, it displays the [version], and then it disappears; “power indicator “lights on, but there’s no display, the machine is at “OFF” state.

2. The machine is at “OFF state”, press key once”, hopper displaying area shows "ON", it enters the “preparation state”; when machine is ready, press again, the screen displays”r n”, once shortage indicator appears, press again to return preparation state.











3.15.12 Operation Time Setting



3.15.13 Parameter Group 1

Display	Code	Name	Function Description	Parameter	
				Default	Range
	F1	hopper n on-off	ON: start hopper n OFF: stop the loading of hopper n	ON	ON/OFF
	F2	hopper n loading time	set hopper n loading time	30 sec.	0 — 99



Operation Instruction:







1. When machine is at any state, press  key, it enters setting and displays [F1], and alternatively displaying with the hopper signal.
2. Press  or  to select the hopper.
3. Then press  to select the parameter code, it display [F2] and alternatively displaying with hopper signal. Repeat to press  key, it displays parameter code as [F1]->[F2]-> [F1].
4. Press  or  to add up or lessen the parameter.
5. According to step 2 to set other parameters.
6. If parameter setting finished, press  or  key, it ends parameter “setting state” and return “operation state” or “preparation state.”



3.15.14 Parameter Group 2

Display	Code	Name	Function Description	Parameter	
				Default	Range
	F3	hopper n preparation time	preparation time of hopper n	3 secs.	0 — 99
	F4	hopper n shut-off time	Set shut-off time of hopper n (Note: it adds up to total loading time, such as loading time of hopper 2 =F2+F4)	5 secs.	0 — 99
	F5	hopper n shut-off valve selection	hopper n is available to select any of the shut-off valve for output	Hopper 1=0 Hopper 2=2 Hopper 3=0 Hopper 4=4	0 — 4



3.15.15 Parameter Group 3

Display	Code	Name	Function Description	Parameter	
				Default	Range
	P1	the number of shortage alarm	when no material for loading after several suctions, it sends shortage alarm, and display [A1]	3 times	0 — 99
	P2	shortage waiting time	when no material for loading, it processes next suction or sent shortage alarm once	30 secs.	0 — 99



			reaching the time.		
	P3	the number of screen cleaning	the required frequency for screen cleaning	10 times	0 — 99
	P4	screen cleaning selection	set screen cleaning before or after suction 0: before 1: after	0	0 — 1
	P5	screen cleaning waiting time	waiting time before screen cleaning	2 secs.	0 — 99
	P6	screen cleaning waiting time	waiting time after screen cleaning	2 secs.	0 — 99
	P7	motor delay	set required time for motor delay	90 secs.	0 — 99
	P8	vacuum break delay	delay time of vacuum breaking valve start after the loading	2 secs.	0 — 99
	P9	motor delay time unit	set [P7] time unit [01]: unit is 1 sec., [02]: unit is 2 secs. [10]:unit is 10 secs.	1 sec.	1 — 10
	PA	loading time unit	1.1sec 2.2ec 3.3sec ... 10.10sec	1 sec.	1 — 10
	Pb	intermittence of ON time	0 : constantly ON	2 secs.	0 — 99

		screen cleaning			
	Pc	Intermittence O F F time of screen cleaning	0 : constantly O N	1 sec.	0 — 99
	Pd	screen cleaning time	screen cleaning time < Note 1>	15 secs.	0 — 99

Note 1: screen cleaning time =Pd+P5+P6 , when P2 > Pd+P5+P6 , the screen cleaning time =Pd+P5+P6 , when P2 < Pd+P5+P6, the screen cleaning time=P

Note 2: repeat (RESET) and when it selects P6, press  +  + 
simultaneously

3.15.16 Parameter Group 4

Display	Code	Name	Function Description	Parameter	
				Default	Range
	F9	hopper shortage signal detecting time	hopper 1-4 shortage signal detecting time (0.01sec) (Note 1) (Note 2)	64	0 — FF
	FA	hopper discharge detecting time	hopper 1-4 discharge detecting time ; (0.01sec)(Note 1)(Note 3)	1E	0 — FF

Note 1: A=10 B=11 C=12 D=13 E=14 F=15 (hexadecimal)

Note 2: 64= (6*16)+4=100 100*0.01=1 sec

Note 3: 1E= (1*16)+14=30 30*0.01=0.3 sec

3.16 Alarm Instruction

1. After several loadings in shortage of material or motor overloads, the machine stops and sends the alarm. At the moment, press  key to stop the machine. Wait till the material re-filling or trouble-shooting then start the machine.

2. The alarm is signal output of the intermittent time

3. Alarm Code:

	Fault	Alarm Code
1	hopper material shortage	NM
2	motor overload	A1
3	over pressure	A2
4	abnormal power off (abnormal shutdown)	A3

4. Trouble-shooting

4.1 Error Code Instruction

Table: 4-1: Error Code Parameter

Error Code	Description
E-01	thermocouple break
E-02	power reverse, default phase
E-03	blower overload
E-04	drying temperature over EGO value
E-05	drying temperature over system maximum temperature
E-07	overheat protection ($PV \geq SV +$ set value, send alarm)
E-08	memory error
E-09	honeycomb rotor fault
E-10	regeneration temperature over EGO value
E-11	thermocouple "+, -" wrong connection
E-12	PID auto-turning error

Failure	Possible Reason	Trouble-shooting
High dew-point indicator lights on	1. Return air over temperature	1. Check cooling water temperature (below 40°C)
	2. Rotor improper speed	2. Adjust motor speed regulator properly (Default is 4)
	3. Regeneration temp. improper set	3. Reset regeneration temperature (Default H5 is 80°C, H4 is 150°C)
	4. Rotor blocked	4. Check or clean the rotor.
	5. Filter blocked	5. Clean or replace
	6. Heat-resistant air pipe leakage	6. Check air pipe or connector
	7. Machine start less than 30 mins	7. Confirm it after 30 mins operation
	8. Rotor not work	8. Check if motor, speed regulator or belt has damage
	9. Motor reverse running	9. Check if motor runs in reverse direction
	10. System insufficient drying capacity	10. Replace large system
	11. Upper & lower honeycomb cover air leak	11. Check or replace sealing component

System can't operate	1. Main power switch disconnected	1. Turn off main power switch
	2. Timer switch at ON state	2. Reset timer power-off button and re-start
	3. Motor overload or power phase reverse	3. Check if circulation, regeneration motor and power supply works normally.
Material shortage for a long time, suction blower doesn't work	1. Main power switch disconnected or at ON position	1. Close main power switch
	2. Hopper photosensor, microswitch poor contact	2. Adjust or replace
	3. Signal cable break	3. Re-connect or replace
Motor doesn't run	1. Thermo-relay trips	1. Check the reason and reset
	2. Contactor doesn't match.	2. Check whether it is burnt.
	3. Power default phase or motor burnt	3. Check or replace
Material is full but suction blower continuous	1. Photosensor or micro-switch is connected through	1. Check or replace
	2. Signal cable short circuit	2. Check signal cable
	3. Contactor failure or contact conglutinated	3. Check or replace
	4. PLC error	4. Check or replace
After several loading, the hopper is still not full	1. Material is used up	1. Fill the material
	2. Air pipe leakage	2. Check or replace
	3. Filter blocked	3. Clean
	4. Diaphragm valve or shut-off valve closed	4. Check if the air pressure of diaphragm valve and shut-off valve is enough, and solenoid valve is burnt, circuit connection is well connected or not.
	5. Motor blade error	5. Check and repair
E-13 Low temperature alarm	1. Pipe heater fault	1. Check and replace
	2. Parameter setting error	2. Adjust F-40 and F-41 setting value
E-12 Heater	1. Lack of power or failure	1. Check and replace
	2. Parameter setting error	2. Adjust F-42 setting value

5. Repair and Maintenance

Clean the anti-dust screen.
Period: daily.

Check temperature control accuracy.
Period: daily.

Check whether dew-point is correct (with dew-point monitor).
Period: daily.

Check if contactor works normally.
Period: yearly.

Replace the PC board.
Period: 3 years

Replace the thermo-fuse switch.
Period: 3 years

Check whether overheat protective device works normally (heater trips once reaching the set value)
Period: daily.

Clean the cooler.
Period: 6 months

Check if the air pipe is disconnected, loose or has leakage.
Period: daily.

Honeycomb Maintenance

- a. Check if the gear motor or synchronous belt has any damage.
Period: 6 months
- b. Clean the honeycomb.
Period: 6 months

Replace the pipe heater once damaged.

Clean the filter.
Period: daily.

Clean the blower.
Clean the dust inside or outside blower.
Period: monthly

- b. Replace the bearing, oil seal and silencer.
Replace them regularly according to the usage.
- c. Replace the blade, shell and metal screen.
Replace them regularly according to the usage.

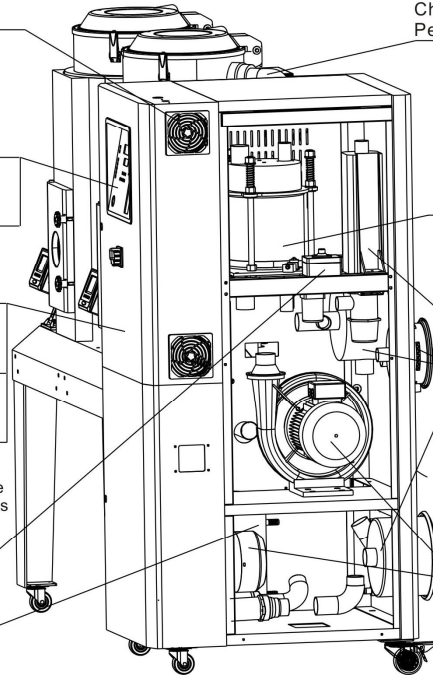

6. Honeycomb-rotor

6.1.1 What is Honeycomb-rotor

The main body of the honeycomb-rotor is a honeycomb, made by ceramic fibre and organic additives, sintered under high temperature with molecular sieve and silica gel, to be strongly bonded together and form a solid and hard surface. Not like common molecular sieve, which will produce dusts and fines to pollute raw materials when aging or become saturated requiring regular replacement, the moisture of return air is quickly absorbed by numerous tunnels before coming out of the rotor to form low dew-point air. At the same time, regenerating blower takes dry air into the honeycomb-rotor from an opposite direction to regenerate the rotor.

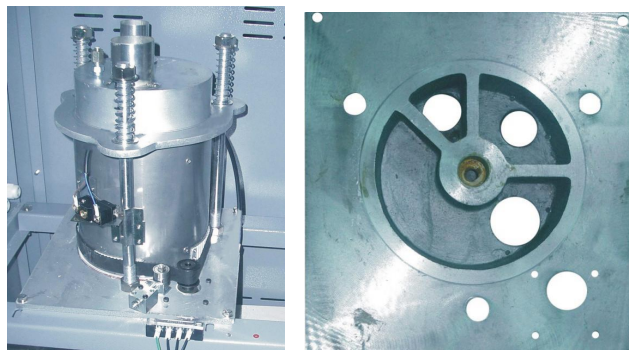

Picture 6-1: Honeycomb rotor

6.1.2 Installation of the Rotor

- 1) The upper and lower lid of honey-comb should install Teflon gasket (Fig. 1). Use 4 screws to fix the rotor base on the machine frame firmly, and then install the shaft accordingly (Fig. 2).

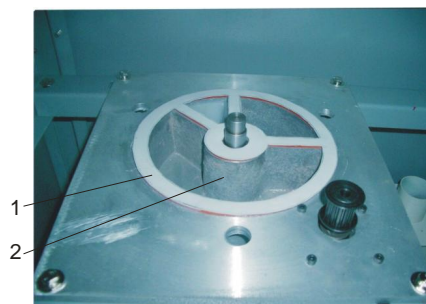

Picture 6-2: Honeycomb-rotor installation steps 1

2) Install and fix the main support screws (Fig. 3).

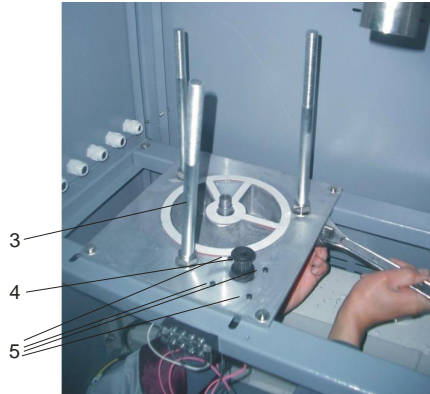

Picture 6-3: Honeycomb-rotor installation steps 2

3) Fit the transmission belt in proper position (Fig. 6)..



Picture 6-4: Honeycomb-rotor installation steps 3

4) Install the honeycomb-rotor (Fig. 9) and transmission belt (Fig. 12). Fix the rotor top cover (Fig. 8). Fit all springs and tighten the screws (Fig. 7). Install both the transmission belt (Fig. 13) and belt tension regulator (Fig. 14). Install micro-switch and fixed board firmly (Fig. 10).

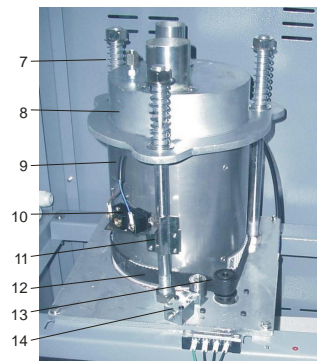

Picture 6-5: Honeycomb-rotor installation steps 4

6.1.3 Cleaning of Honeycomb

Honeycomb Rotor cleaning steps:

- 1) Use a vacuum-cleaner with brush to suck up the dust on rotor surface.
- 2) Blow off the dust in the rotor channels with compressed air.
- 3) If there is dirt sticking to the channel walls inside the rotor, cleaning steps are as follows:
 - a. Saturate the rotor by blowing humid air (higher than 60%RH) through the rotor without having regeneration circuit on. This can be done by just turning the regeneration heater off and still have the process blower running if process air has high humidity. If the process air is too dry try to put a humidifier in the air stream. Do this for one hour.
 - b. According to the character of the dirt, sink the rotor into water with cleaning agent in it (PH value 3~2 liquid is applied to silica gel, PH value 7~10 applied to molecular valve). Greasy dirt should be put into a detergent solution with xylene. 15 minutes cleaning is suggested.
 - c. Take the rotor out of the liquid and let it rest with the channels vertically for 5 minutes so the liquid can run out.
 - d. Blow off the residual liquid in the channels with compressed air.
 - e. Put the rotor back into the dehumidifier and run the unit with regeneration circuit (the regeneration temperature between 50°C and 60°C) on for at least one hour.



Note!

1. Note that in the dry air and wet air outlets, there will be high concentrations liquid out for some time. If a solvent has been used, there will be a residual smell for several days.
2. For some dirt which is greasy and sticky in the rotor, 100% elimination is impossible. The only one thing you can do is to replace the rotor for the cleaned rotor performance can only be recovered partly.



Note!

Please note that some dirt, like oil mist or other types of sticky mist, is almost impossible to clean out effectively so the rotor may not be cleaned effectively and has to be replaced. This may be happened if it is polluted

by exhaust gas of machines driven by diesel oil. After cleaning, the dehumidifying capacity of the rotor may be as good as before, but usually it would be affected. If you need special service for cleaning the rotor, feel free to contact us.

6.2 Heater Assemblies

- 1) Install the heating pipe in the heater.
- 2) Fix the heater into the housing. (See right picture)



Warning!

Hot surfaces could burn hands. Take care of high temperature!

This label should be stick to the shell of heater.



1



2

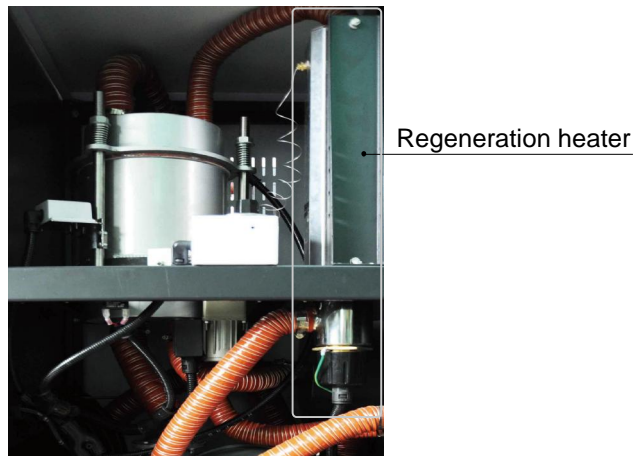

Picture 6-6: Heater Assemblies

6.3 Blowers

6.3.1 Drying Blower

- 1) Fix inlet/outlet flange of blower, and tighten 4 screws securely.
- 2) Connect the blower with electrical source.
- 3) Install the blower on the machine frame.

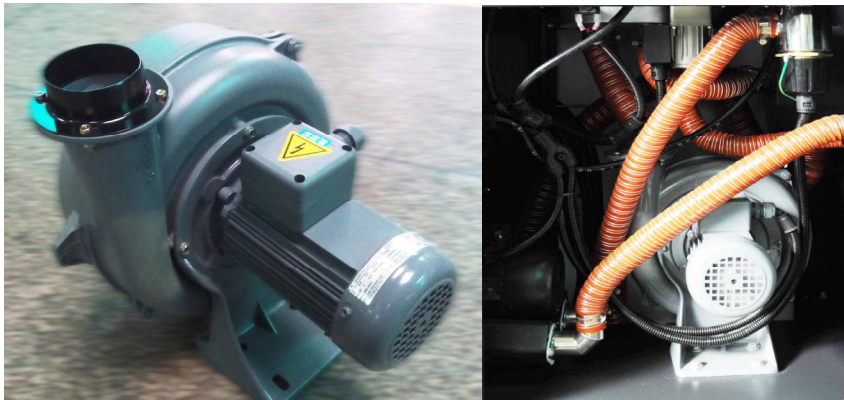

Picture 6-7: Installation of Blowers

6.3.2 Regeneration Blower

- 1) Fix inlet/outlet flange of blower, and tighten 4 screws securely.
- 2) Install the blower on the machine frame.
- 3) Connect the blower with electrical source.

6.3.3 Conveying Blower

- 1) Fix inlet/outlet flange of blower, and tighten 4 screws securely.
- 2) Connect the blower with electrical power source.
- 3) Install the blower on the machine frame.
- 4) Fix the three-way valve (See Figure. 1).
- 5) Install the solenoid valve, and then tighten 2 screws on the machine frame

6.3.4 Installation of Drying Hopper

- 1) Install drying hopper on the machine frame.
- 2) Fix the shut-off valve adaptor on the suction box.
- 3) Install the shut-off valve on the suction box.

6.3.5 Filter & Pressure Regulating Valve

- 1) Switch on the air source.
- 2) Pull the black pressure adjusting knob 1 upward and rotate it, observe the pressure gauge 2, generally a 0.5 Mpa pressure is advisable.
- 3) Push back the black knob 1.

6.3.6 EGO



The EGO value has been setting before out factory, Don't modify it.



Picture 6-8: EGO

6.4 Filter & Pressure Regulating Valve

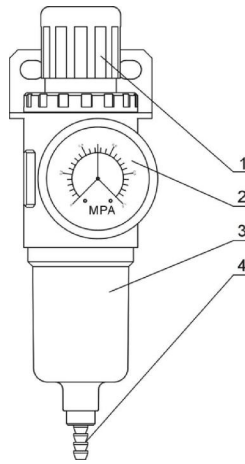

Components:

1. pressure regulating button
2. pressure gauge
3. water cup
4. water outlet

Pic. 6-9: Filter & Pressure Regulating Valve

6.4.1 Operation Steps of Filter & Pressure Regulating Valve

- 1) Connect through air source.
- 2) Pull up the black button 1, then rotate; observe the pointer of pressure gauge 2, adjust it to 0.5Mpa normally.
- 3) Pull down the black button 1 after the adjustment.

6.5 Filter

Please periodically clean the dust on the air filters, once per week.

Cleaning steps:

- 1) Take out the air filter carefully.
- 2) Blow off the dust on the air filter screen and the cover with pressure air.
- 3) Wipe off the barrel wall of air filter with dishcloth.
- 4) After cleaning, place all parts in reversed order carefully.



Picture 6-10: Filter



Note!

Don't make sundries fall into the barrel, when taking out the air filter.

6.5.1 The Useful Life of the Key Parts of the Product

Table 6-1: The useful life of the key parts of the product

Name of the parts	Useful life
Blower	Above 5 years
Process heater	Above 1 year
Regen. heater	Above 1 year
Contactoer	Above 2000,000 act
Honeycomb	5 years

6.6 Cooler Clear Step

- 1) Disassemble the cooler's pipe and screw, and remove the cooler out of the chiller.
- 2) Release the fixed screw on the upper and lower cover of cooler and disassemble the cover.
- 3) Use brushes, compressed air or low pressure water to clean the dust and sundries on the cooler fan and copper pipe. Notes: water residue on the cooler fan and copper pipe should be dried with compressed air.
- 4) Make the cooler's upper and lower cover junction clean enough and smear the silica gel then fixed the covers with screws.
- 5) Put the cooler on the air at least 4 hours to make the silica gel drying enough then fix the cooler on the chiller and connect all pipes.

6.7 Maintenance Schedule

6.7.1 General Machine Information

Model _____ SN _____ Manufacture date _____

Voltage _____ Φ _____ V Frequency _____ Hz Power _____ kW

6.7.2 Installation & Inspection

- Check if the air pipe are tightly connected.
- Check if the material clearance door tightly closed.
- Check if the air pipes are correctly connected.
- Check if there are damages of the honeycomb.

Inspection of Electric Components

- Voltage _____ V _____ Hz
- Fuse melt current: 1 Phase _____ A 3 Phases _____ A
- Check phase sequence of the power supply.
- Check the rotating direction of regeneration blower.
- Check the rotating direction of conveying blower.

Check Air Supply of Compressor

- Compressed air pressure _____ bar
- Air flow _____ L/min
- Check if the compressed air purified or not

6.7.3 Daily Checking

- Check the switch of the machine.
- Check auto start-up of the machine.
- Check the temperature controller.
- Clean the filter.
- Check whether overheat protection is normal.
- Check whether dew-point is normal.

6.7.4 Weekly Checking

- Check all the electric wires.
- Check loose electric connections.
- Check and clean compressed air filter and regulator.
- Check magnetic valve.
- Check motor overload relay and phase-reversed prevention function.
- Check whether air pipe is shed, leaked and loose.

6.7.5 Monthly Checking

- Check if the belt is loose or not.
- Check gear box working conditions.
- Check if there are leakages in the honeycomb.

6.7.6 Half-yearly Checking

- Check if hot air pipe is broken or not.
- Check dehumidifier heater.
- Check regulation blower/material conveying blower/fans.
- Check whether honey-comb rotor belt is damaged.
- Clean the cooler.

6.7.7 Yearly Checking

- Check whether the contactor is normal 1.

6.7.8 3 year Checking

- PC board renewal.
- No fuse breaker renewal.

Note: 1. Manufacturer laboratory data for AC contactor is two million times in life. we suggest service life for one million four hundred thousand times, if work eight hours per day, recommended replacing frequency is 1.5 years, if work day and night, replacement is suggested to be done every six months.