

机型版本 Ver.D

					制图	版号	H	标题	SGS-6080S	图号	SGS-6080S-CE-400V-H-1	比例	第 1 张
					设计	核准		主电路图				标准	CE 共 11 张
					校对							机器电压	3Φ400V
标记	更改前	更改后	更改人	日期	审核	日期	20211215					机器频率	50Hz

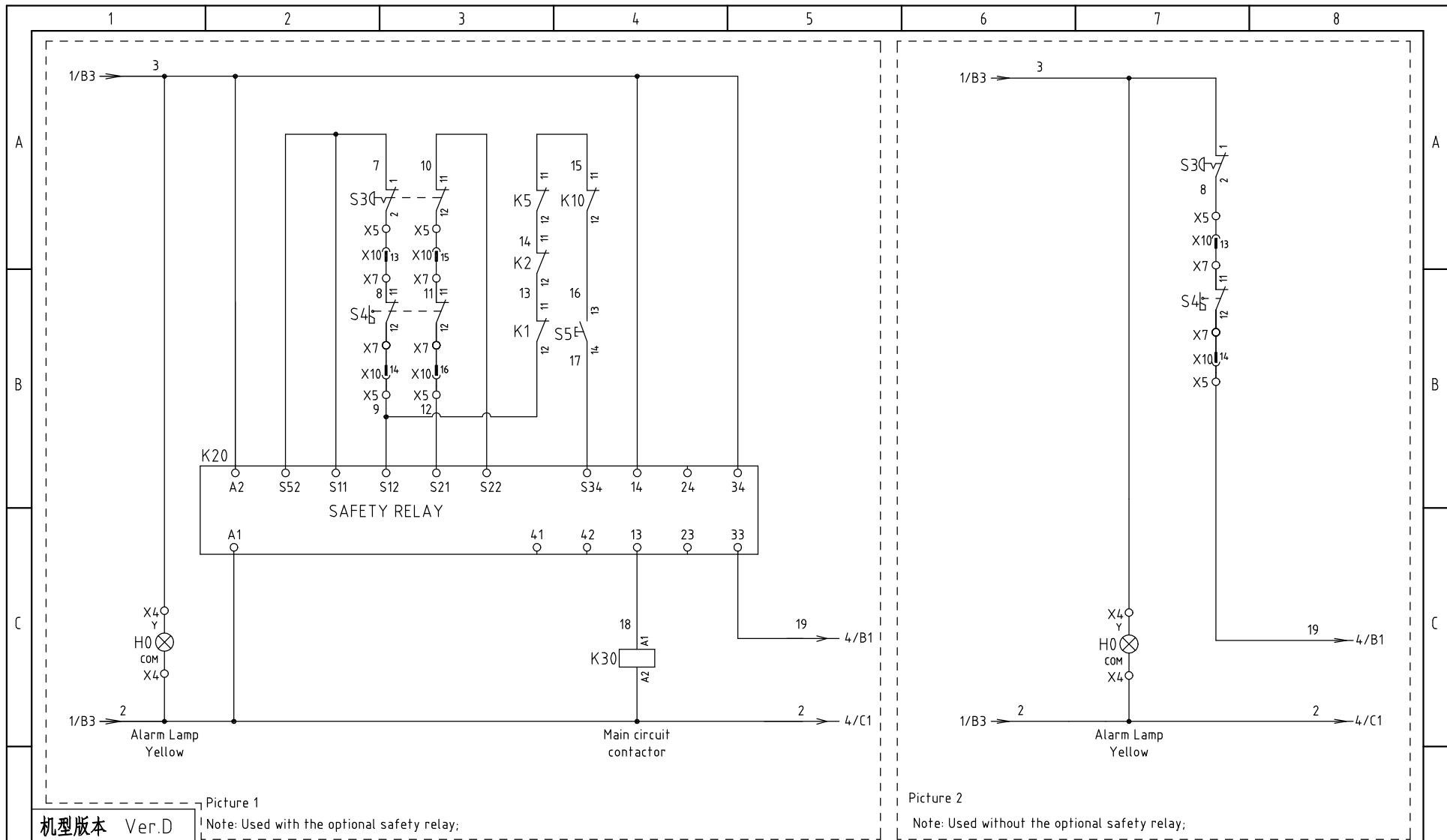



机型版本 Ver.D

Note: Used with the optional safety relay;

Note: Used without the optional safety relay;

					制图	版号	H	标题	SGS-6080S	图号	SGS-6080S-CE-400V-H-2	比例	第 2 张
					设计	核准		控制电路图一		标准	CE	共 11 张	
					校对			 信易電熱機械股份有限公司 Shini Plastics Technologies, Inc.	机器电压	3Φ400V			
标记	更改前	更改后	更改人	日期	审核	日期	20211215		机器频率	50Hz			

1 2 3 4 5 6 7 8

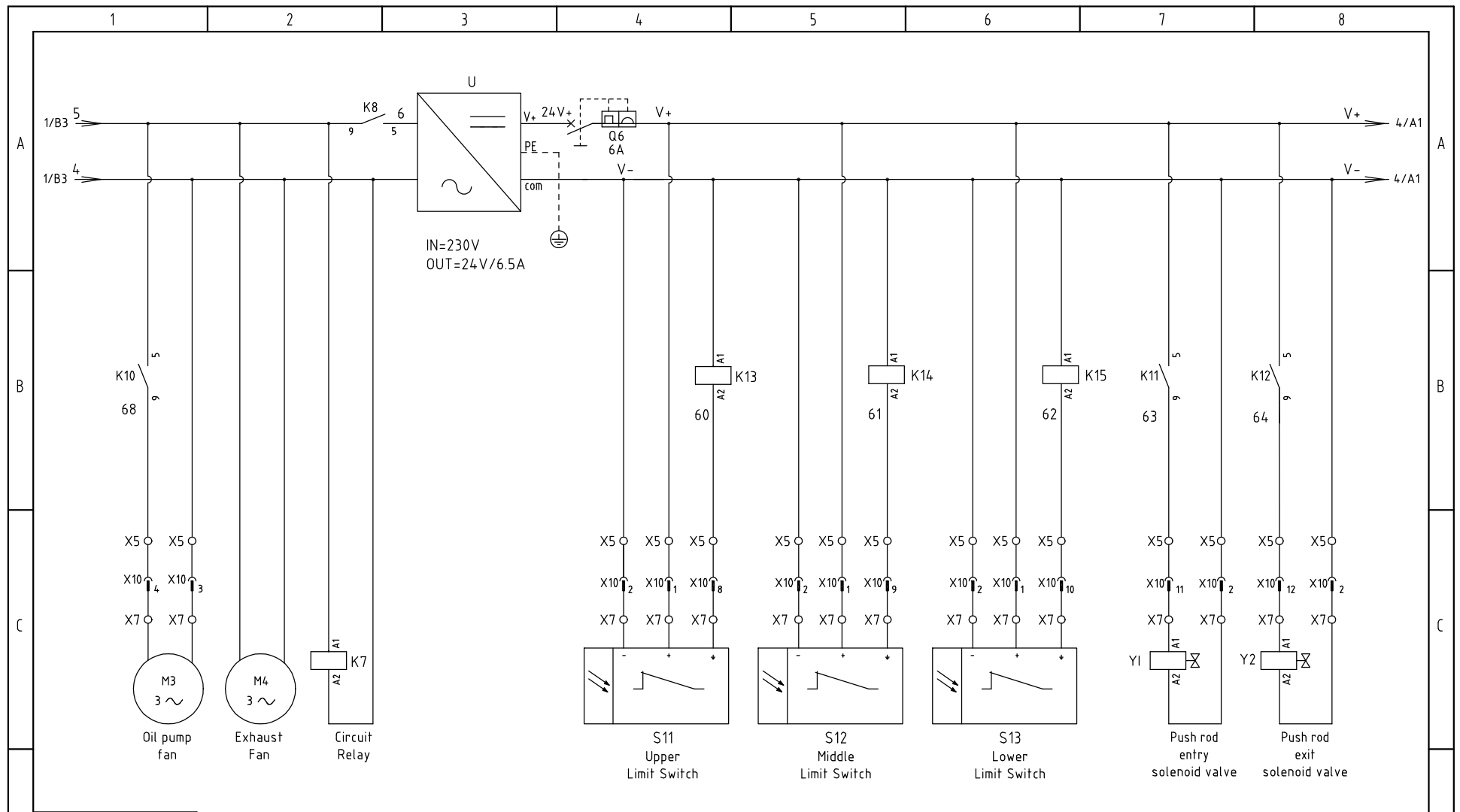

机型版本 Ver.D

					制图		版号	H
					设计		核	
					校对		准	
标记	更改前	更改后	更改人	日期	审核		日期	20211215

标题 SGS-6080S
控制电路图二

图号 SGS-6080S-CE-400V-H-3



比例	第 3 张
标准	CE 共 11 张
机器电压	3φ400V
机器频率	50Hz

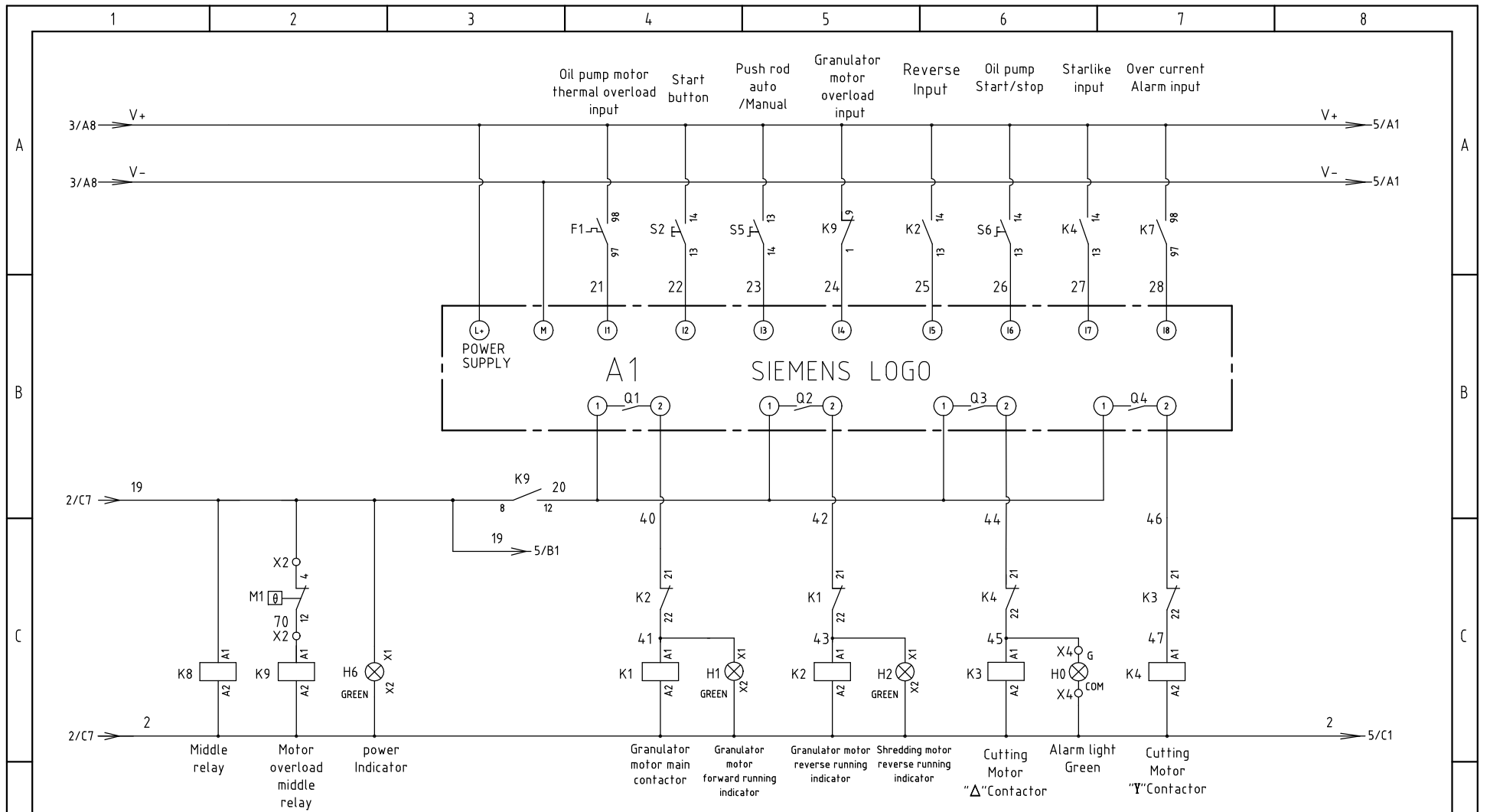

机型版本 Ver.D

					制图	版号	H	标题	SGS-6080S	图号	SGS-6080S-CE-400V-H-4	比例	第 4 张	
					设计	核准		控制电路图三				标准	CE	共 11 张
					校对	日期	20211215	 信易電熱機械股份有限公司 Shini Plastics Technologies, Inc.	机器电压	3Φ400V				
标记	更改前	更改后	更改人	日期	审核	日期	20211215		机器频率	50Hz				

1 2 3 4 5 6 7 8

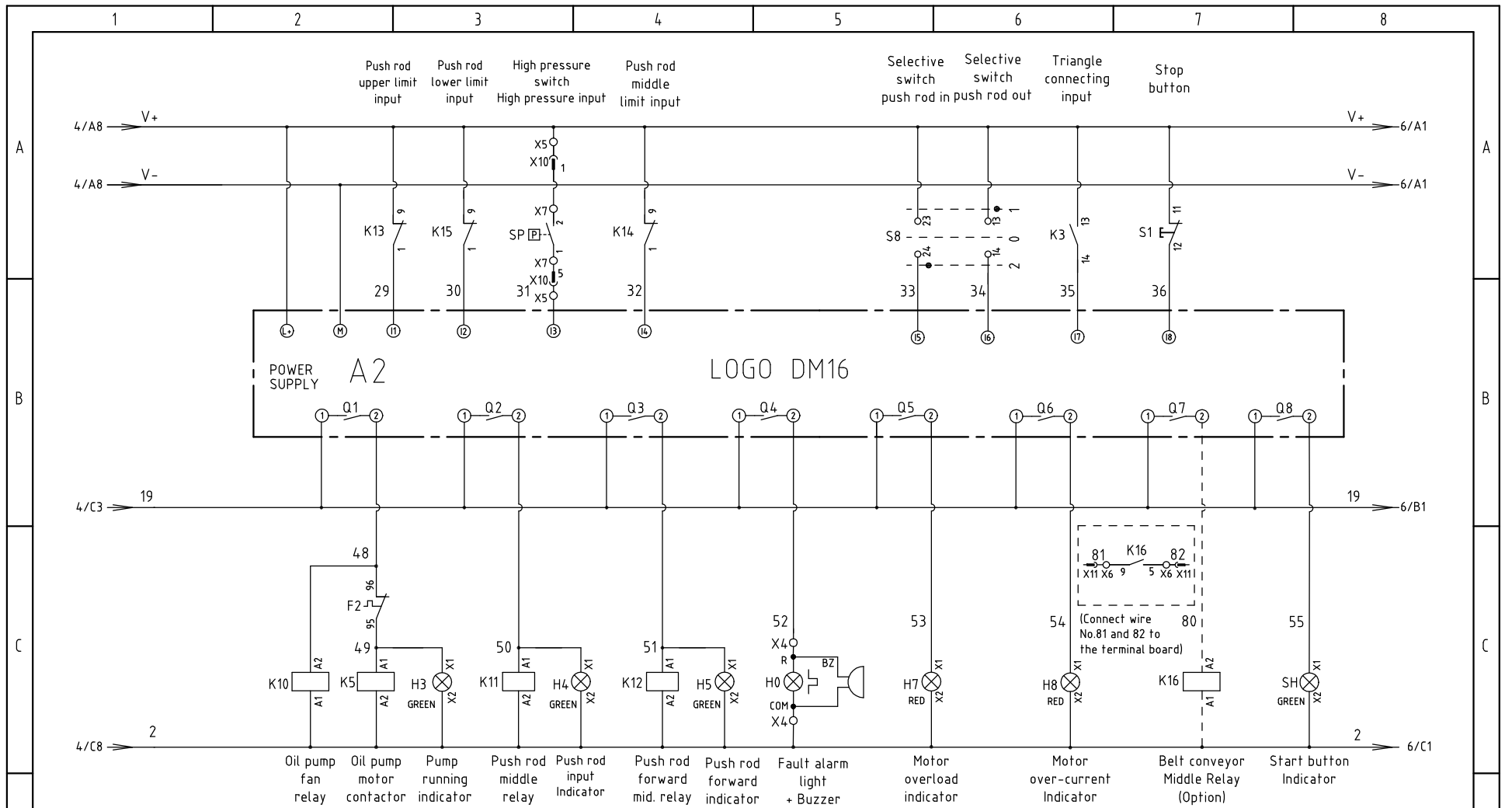

机型版本 Ver.D

					制图	版号	H	标题	SGS-6080S	图号	SGS-6080S-CE-400V-H-5	比例	第 5 张	
					设计	核准		控制电路图四				标准	CE	共 11 张
					校对			 信易電熱機械股份有限公司 Shini Plastics Technologies, Inc.	机器电压	3Φ400V				
标记	更改前	更改后	更改人	日期	审核	日期	20211215		机器频率	50Hz				

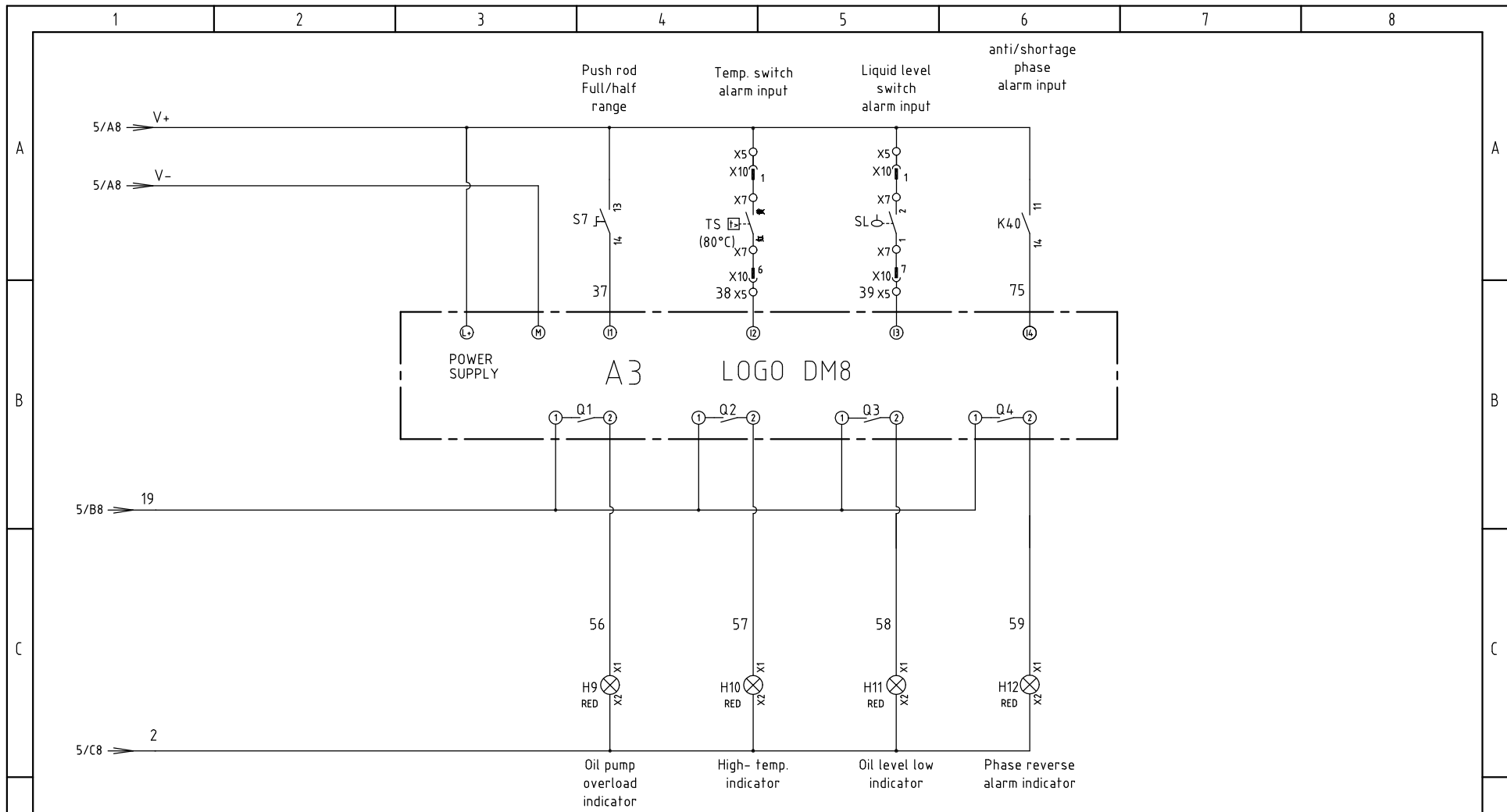

机型版本 Ver.D

					制图		版号	H	标题	SGS-6080S	图号	SGS-6080S-CE-400V-H-6	比例	第 6 张
					设计		核 准		控制电路图五		标准	CE	共 11 张	
					校对				审核		机器电压	3φ400V		机器频率
标记	更改前	更改后	更改人	日期	审核		日期	20211215	 信易電熱機械股份有限公司 Shini Plastics Technologies, Inc.					
1	2	3	4	5	6	7	8							

1 2 3 4 5 6 7 8

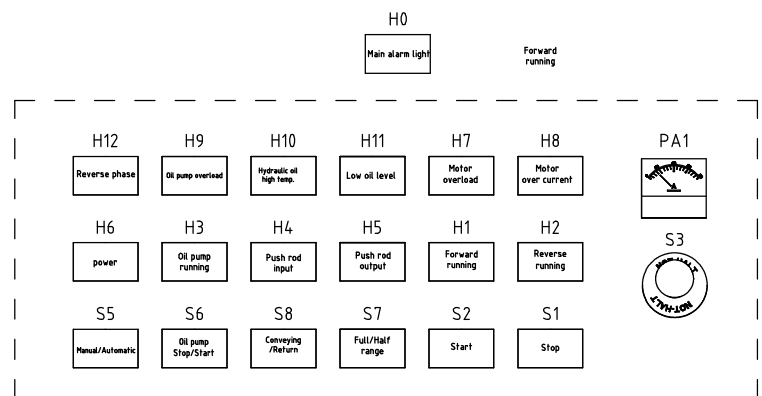

Control Panel Layout

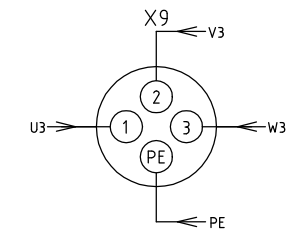

Anti-proof connector (connect to X8 terminal)

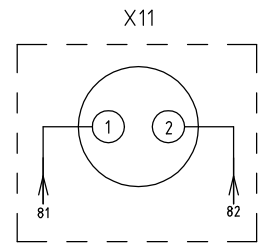

metal connector wiring connect to belt conveyor (option)

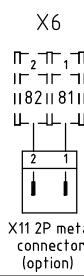
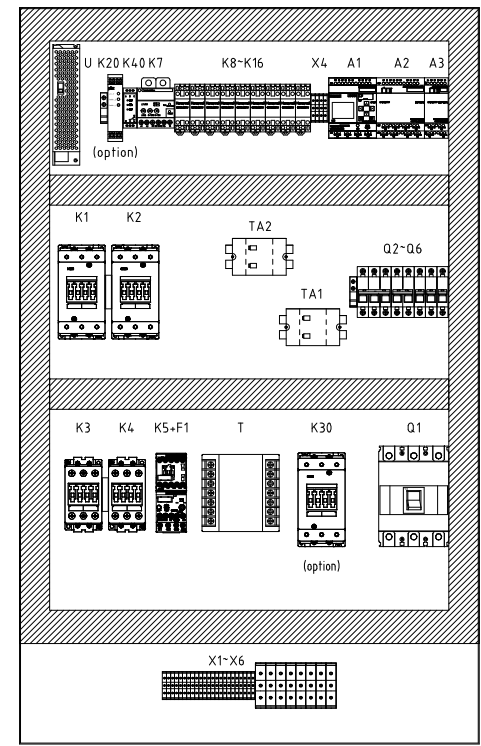
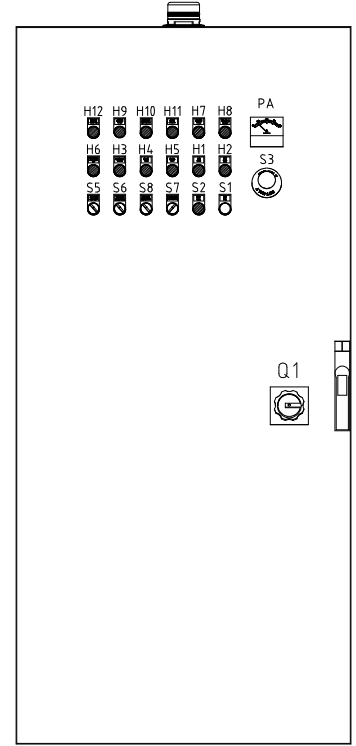

X11 2P metal connector (option)

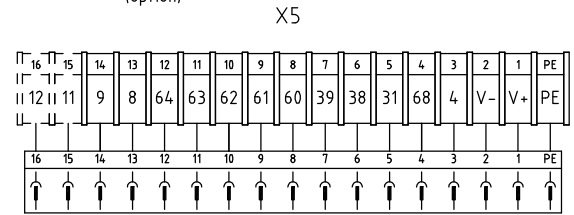

X10 16P heavy-duty connector (When safety relay is not selected, No. 9 is changed to No. 19)

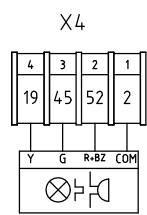

Alarm light red, yel, gre.

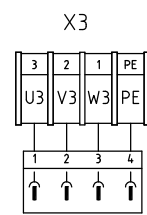

X9 water-proof connector

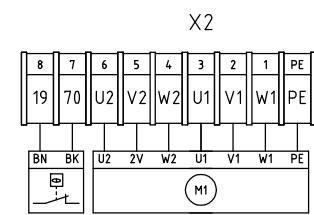

motor thermal protector cutting motor

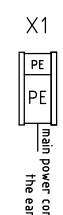

main power connected to the earth

机型版本 Ver.D

制图	版号	H	标题	SGS-6080S	图号	SGS-6080S-CE-400V-H-7	比例	第 7 张	
设计	核准		电气元件布置图一				标准	CE 共 11 张	
校对							机器电压	3φ400V	
标记	更改前	更改后	更改人	日期	审核	日期	20211215	机器频率	50Hz



信易電熱機械股份有限公司
Shini Plastics Technologies, Inc.

1 2 3 4 5 6 7 8

1 2 3 4 5 6 7 8

A

A

Note: 16P heavy-duty connector definition

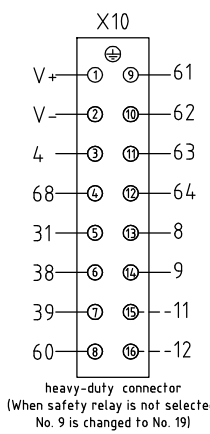

Pin No.	Function	Description
1	DC24V(V+)	DC power common end
2	DC24V(V-)	
3	AC230V(zero wire)	Oil pump fan
4	AC230V(fire wire)	
5	DC24V power signal	pressure switch
6	DC24V power signal	temp. switch
7	DC24V power signal	liquid level switch
8	DC24V power signal	upper limit switch
9	DC24V power signal	middle limit switch
10	DC24V power signal	lower limit switch
11	DC24V power signal	conveying solenoid valve
12	DC24V power signal	return of material solenoid valve
13	AC24V power signal	safety switch
14	AC24V power signal	
15	AC24V power signal	
16	AC24V power signal	

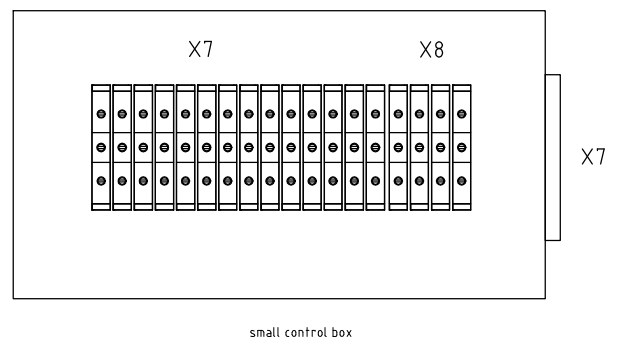

B

B

C

C

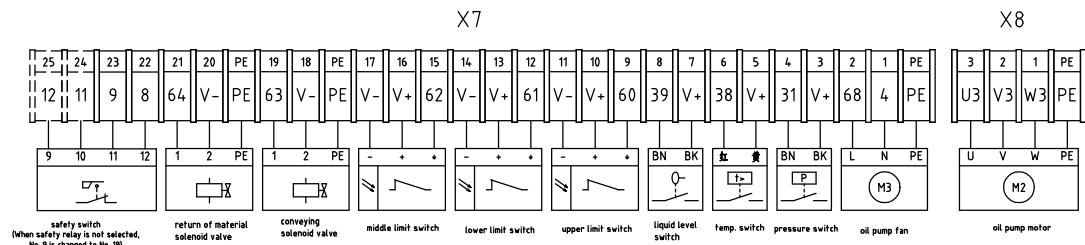

机型版本 Ver.D

					制图	版号	H	标题	SGS-6080S	图号	SGS-6080S-CE-400V-H-8	比例	第 8 张
					设计	核准		电气元件布置图二				标准	CE 共 11 张
					校对			信易電熱機械股份有限公司 Shini Plastics Technologies, Inc.		机器电压		3Φ400V	
标记	更改前	更改后	更改人	日期	审核	日期	20211215			机器频率		50Hz	

1 2 3 4 5 6 7 8

D

D

1		2		3		4		5		6		7		8	
NO.	Symbol	Name		Manufacturer		Type		Specification		Number	Material number		Remark		
A	1	Q1	Breaker circuit breaker		ABB		A2B250TMF160		160A		1	YE41161500000			
	2	Q2	Circuit breaker		TECO		BM-63C		25A		1	YE40302503000			
	3	Q3	Circuit breaker		TECO		BM-63C/2006S		6A 2P		1	YE40200600000			
	4	Q4	Circuit breaker		TECO		BM-63C/1010S		10A 1P		1	YE40101000100			
	5	Q5	Circuit breaker		TECO		BM-63C/1003S		3A 1P		1	YE40100203000			
	6	Q6	Circuit breaker		TECO		BM-63C/1006S		6A 1P		1	YE40100600100			
	7	K1,K2	Contactor		SIEMENS		3RT5046-1AC20		24 VAC 50/60Hz		2	YE00504602600			
B	8	K3,K4	Contactor		SIEMENS		3RT5036-1AC20		24 VAC 50/60Hz		2	YE00503602600			
	9		Auxiliary contact		SIEMENS		3RH5921-1CA01		1NC		4	YE00592110100			
	10		Auxiliary contact		SIEMENS		3RH5921-1CA10		1NO		3	YE00592110000			
	11		Mechanical interlocking		SIEMENS		3RA1924-2B		S2/S3		2	YE00319200000			
	12		Connecting clip		SIEMENS		3RA1932-2D		S2/S3/S6		4	YE90193201300			
	13	K5	Contactor		SIEMENS		3RT6017-1AB02		24 VAC 50/60Hz		1	YE00601702600			
	14	K7	Current relay		Telemecanique		LT4706M7A		0.5~6A/220VAC		1	YE04470600600			
C	15	K8~K12	Middle relay		Honeywell		GR-2C-AC24V		24 VAC		5	YE03022400300			
	16	K13~K15	Middle relay		WEIDMULLER		DRM270024LT		DC24V		3	YE03272400000			
	17	K16	Middle relay		Honeywell		GR-2C-AC24V		24 VAC		1	YE03022400300		(3)	
	18	K20	Safety realy		PILZ		PNOZ×2.8P		24 V AC/DC		1	YE04023000000		(2)	
	19	K30	Contactor		SIEMENS		3RT5054-1AB36		24 VAC 50/60Hz		1	YE00505400900		(2)	
	20	K40	Phase disorder relay		CHAOSHI		ABJ2-12W		380VAC 50/60Hz		1	YE03103800000			
	21	F1	Thermal overload relay		SIEMENS		3RU6116-1HB0		5.5-8A		1	YE01160550000			
	22	TA1 TA2	Current mutual transformer		RATTO		RCT-35		150/5A		2	YE04150500000			
	23	PA	Ammeter		SFIM		DH-670		150/5A		1	YE25671500000			
	24	T	Transfarmer		BAIYUN		IN=400V/415V OUT=24V/230V		350VA/1000MA		1	YE70040007900			
	25	U	DC Power		MEAN WELL		HRP-150-24		24V3.2A		1	YE71246500000			
机型版本 Ver.D		Note: (1) Materials not in the control box; (2) Optional relay options; (3) Belt conveyor options:													
D					制图		版号	H	标题	SGS-6080S	图号	SGS-6080S-CE-400V-H-9		比例	第 9 张
					设计		核		电气元件明细表一		标准	CE	共 11 张		
					校对		准			信易電熱機械股份有限公司		机器电压	3φ400V		
	标记	更改前	更改后	更改人	日期	审核	日期	20211215		Shini Plastics Technologies, Inc.		机器频率	50Hz		
1		2		3		4		5		6		7		8	

1		2		3		4		5		6		7		8		
NO.	Symbol	Name			Manufacturer		Type		Specification			Number	Material number		Remark	
A	26	A1	LOGO host module			SIEMENS		LOGO! 24RCE(with display)		24V AC/DC			1	YE80105200000		
	27	A2	LOGO Extension module			SIEMENS		LOGO! DM16 24R		6ED1055-1NB10-0BA2			1	YE81105500100		
	28	A3	LOGO Extension module			SIEMENS		LOGO! DM8 24R		6ED1055-1HB00-0BA2			1	YE81105500000		
	29	H0	3-color alarm light			SHINI		red. gre. yel.+buzzer		24VAC			1	BL90002401520		(1)
	30	H1 ~ H6	Green indicator			ABB		CL2-502G		24VAC			6	YE83050200100		(1)
	31	H7~ H12	Red indicator			ABB		CL2-502R		24VAC			6	YE83250200400		(1)
	32	S1	Stop button switch			SCHNEIDER		XB2BA22C		400VAC			1	YE11222000000		(1)
B	33	S2(SH)	Start button switch			SCHNEIDER		XB2BW33B1C		24VAC/DC			1	YE11233100000		(1)
	34		Button auxiliary contact			SCHNEIDER		ZB2BE101C		1NO			1	YE00210103100		(1)
	35		Button auxiliary contact			SCHNEIDER		ZB2BE101C		1NO			1	YE00210103100		
	36	S3	Emergency stop botton			SCHNEIDER		XB2BS542C		400VAC			1	YE11254200000		(1)
	37		Button auxiliary contact			SCHNEIDER		ZB2BE102C		1NC			1	YE00210203100		(1)(2)
	38		Emergency stop sign			SCHNEIDER		ZB2BY9330C		yellow bottom with black letter			1	YE90293300000		(1)
	39	S4	Safety swith			TEND		TZ-9212		AC-16			1	YE16921200000		(1)(2)
40	S5 S6 S7	Selective switch			ABB		C2SS2-10B-10		400V/5A			3	YE12210100000		(1)	
41	S8	Selective switch			ABB		C3SS1-10B-20		400V/5A			1	YE12102000000		(1)	
C	42	S11 S12 S13	Limit switch			SONON		SN12E06BPA		DC24V NPN			3	YE14126000000		(1)
	43	X1	Terminal board			Honeywell		GK35PE		35mm ² PE			1	YE60003503500		
	44	X2	Terminal board			Honeywell		GK16		16mm ²			6	YE60001603200		
	45					Honeywell		GK16PE		16mm ² PE			1	YE60001603500		
	46					Honeywell		SK2.5		2.5mm ²			2	YE60002503200		
	47	X3	Terminal board			Honeywell		GK2.5PE		2.5mm ² PE			1	YE60002503400		
	48					Honeywell		SK2.5		2.5mm ²			3	YE60002503200		
	49	X4	Terminal board			Honeywell		SK2.5		2.5mm ²			4	YE60002503200		
50	X5	Terminal board			Honeywell		SK2.5		2.5mm ²			16	YE60002503200			
机型版本 Ver.D		Note: (1) Materials not in the control box; (2) Optional relay options; (3) Belt conveyor options:														
D					制图		版号	H	标题		图号		比例		第 10 张	
					设计		核		SGS-6080S		SGS-6080S-CE-400V-H-10		标准	CE	共 11 张	
					校对		准		电气元件明细表二							
	标记	更改前	更改后	更改人	日期	审核		日期	20211215			信易電熱機械股份有限公司 Shini Plastics Technologies, Inc.		机器电压	3Φ400V	
1		2		3		4		5		6		7		8		

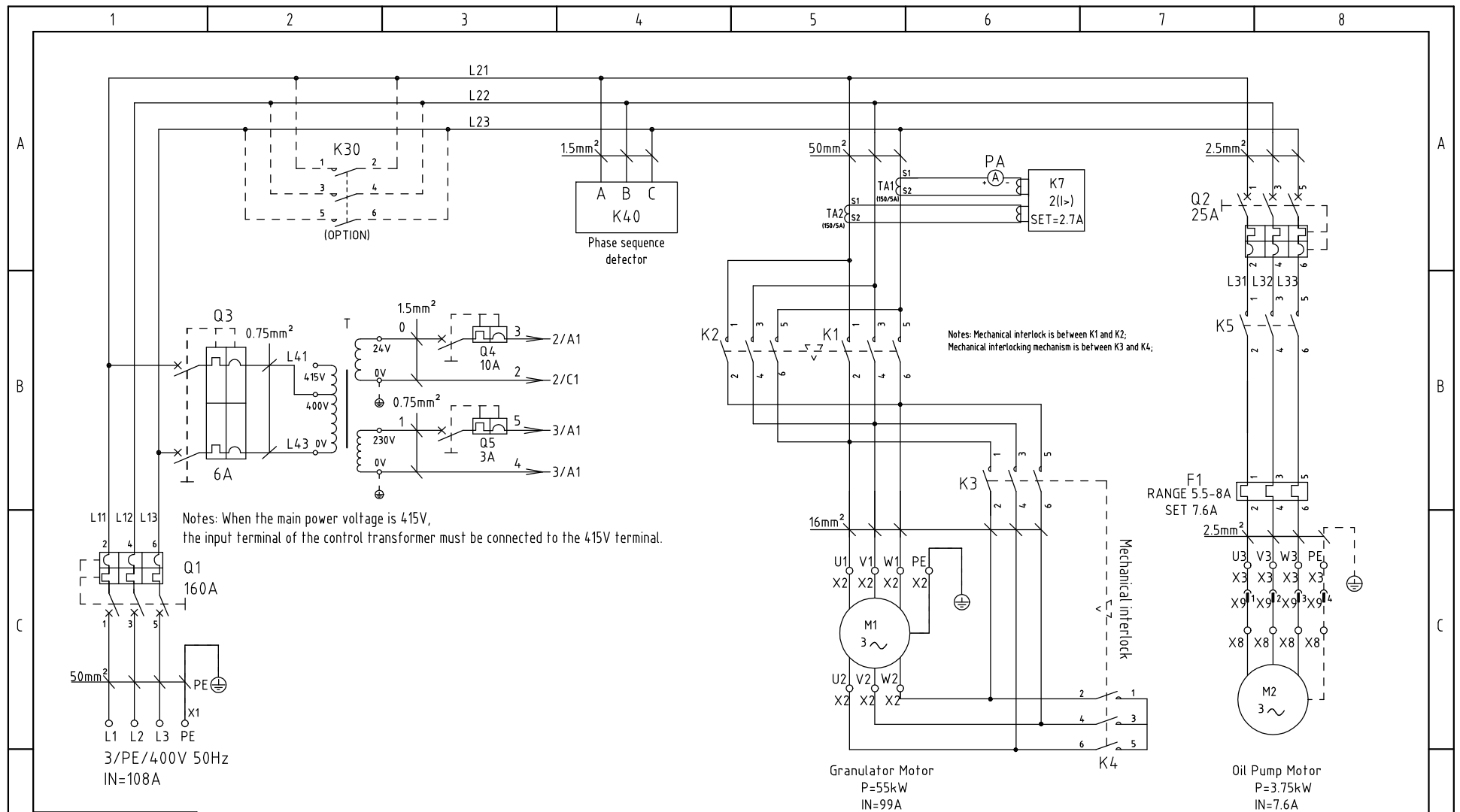

机型版本 Ver.D

					制图	叶健	版号	G	标题	SGS-75120S	图号	SGS-75120S-CE-400V-G-1	比例	第 1 张
					设计	叶健	核		主电路图				标准	CE 共 11 张
					校对		准						机器电压	3Φ400V
标记	更改前	更改后	更改人	日期	审核		日期	20211215					机器频率	50Hz



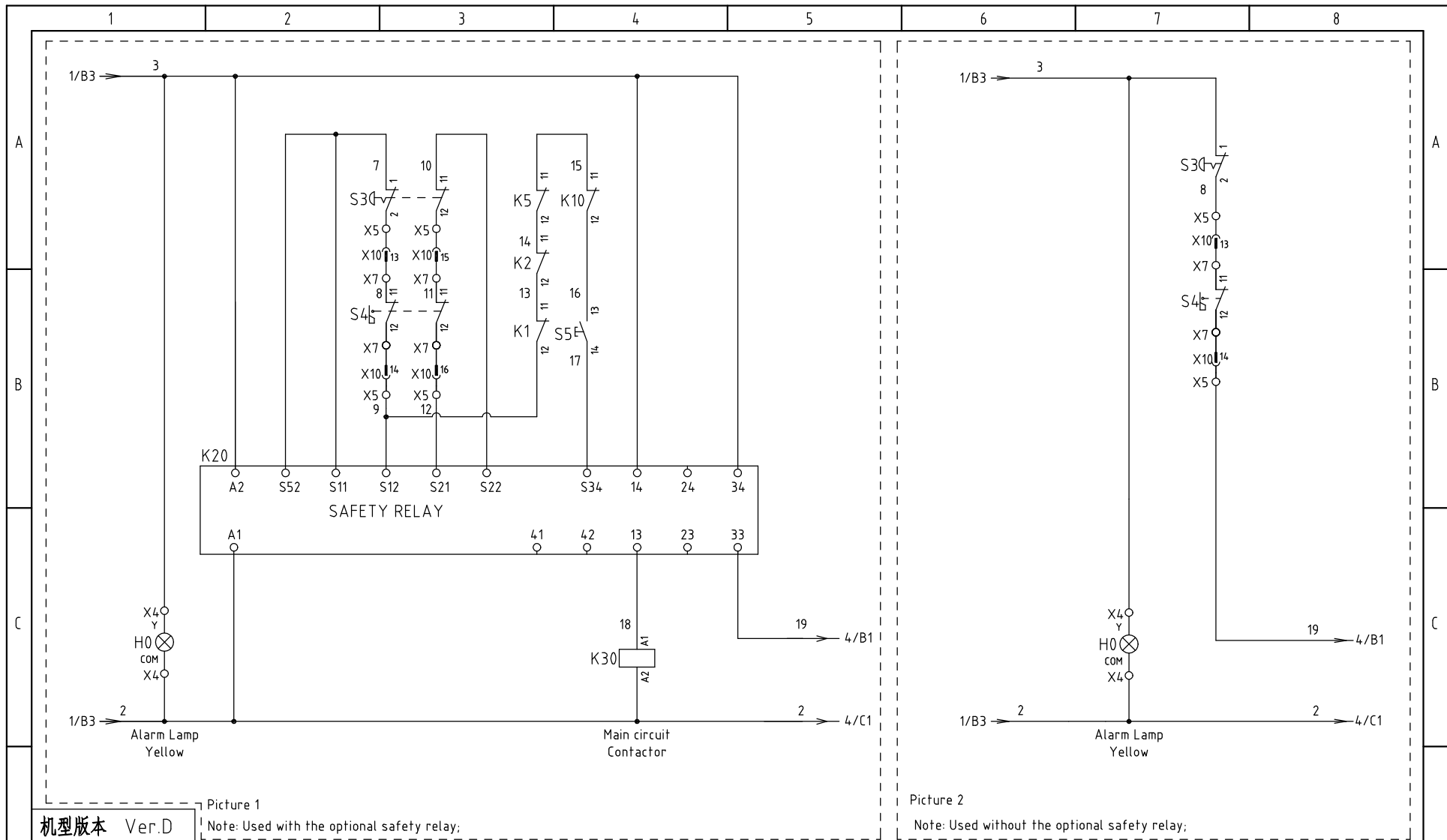

机型版本 Ver.D

Note: Used with the optional safety relay;

Note: Used without the optional safety relay;

					制图	叶健	版号	G	标题	SGS-75120S	图号	SGS-75120S-CE-400V-G-2	比例	第 2 张
					设计	叶健	核准		控制电路图一				标准	CE 共 11 张
					校对		核准		 信易電熱機械股份有限公司 Shini Plastics Technologies, Inc.		机器电压		3Φ400V	
标记	更改前	更改后	更改人	日期	审核	日期	20211215	机器频率			50Hz			

1 2 3 4 5 6 7 8

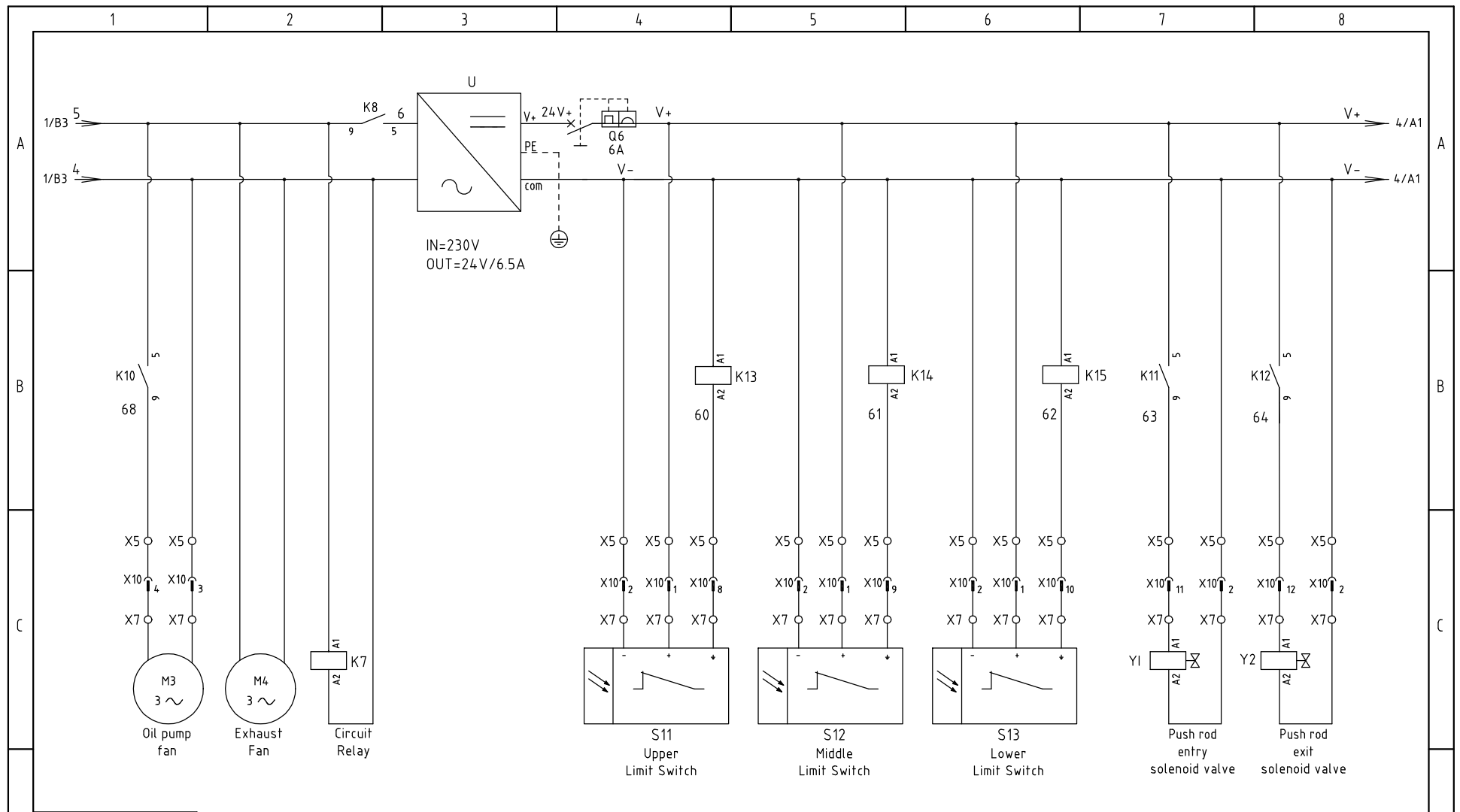

机型版本 Ver.D

					制图	叶健	版号	G
					设计	叶健	核准	
					校对		核准	
标记	更改前	更改后	更改人	日期	审核		日期	20211215

标题 SGS-75120S
控制电路图二

图号 SGS-75120S-CE-400V-G-3



信易电热机械股份有限公司
Shini Plastics Technologies, Inc.

比例	第 3 张
标准	CE 共 11 张
机器电压	3φ400V
机器频率	50Hz

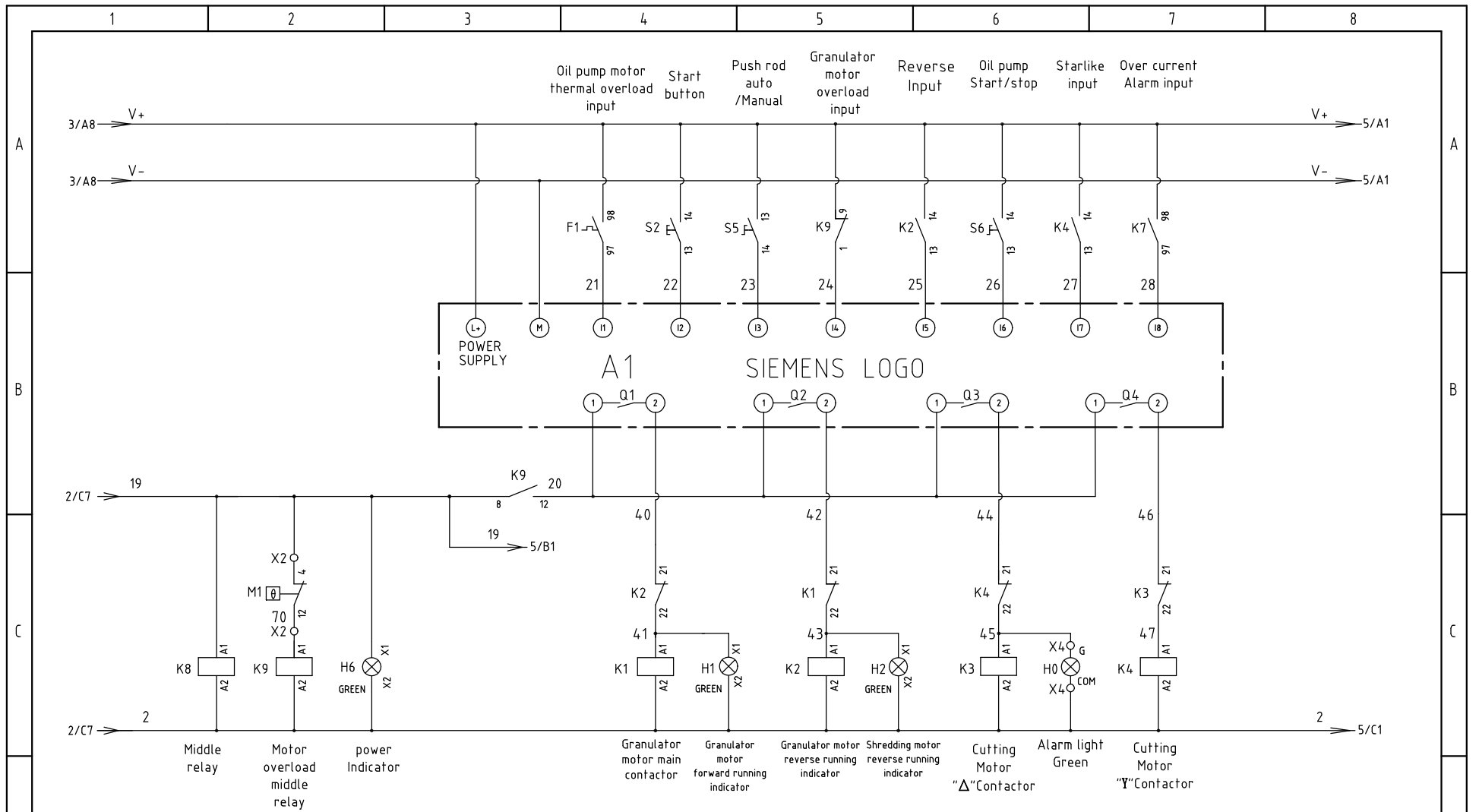

机型版本 Ver.D

					制图	叶健	版号	G
					设计	叶健	核	
					校对		准	
标记	更改前	更改后	更改人	日期	审核		日期	20211215

标题 SGS-75120S
控制电路图三

图号 SGS-75120S-CE-400V-G-4

比例 第 4 张
标准 CE 共 11 张

SHINI 信易電熱機械股份有限公司
Shini Plastics Technologies, Inc.

机器电压 3Φ400V
机器频率 50Hz

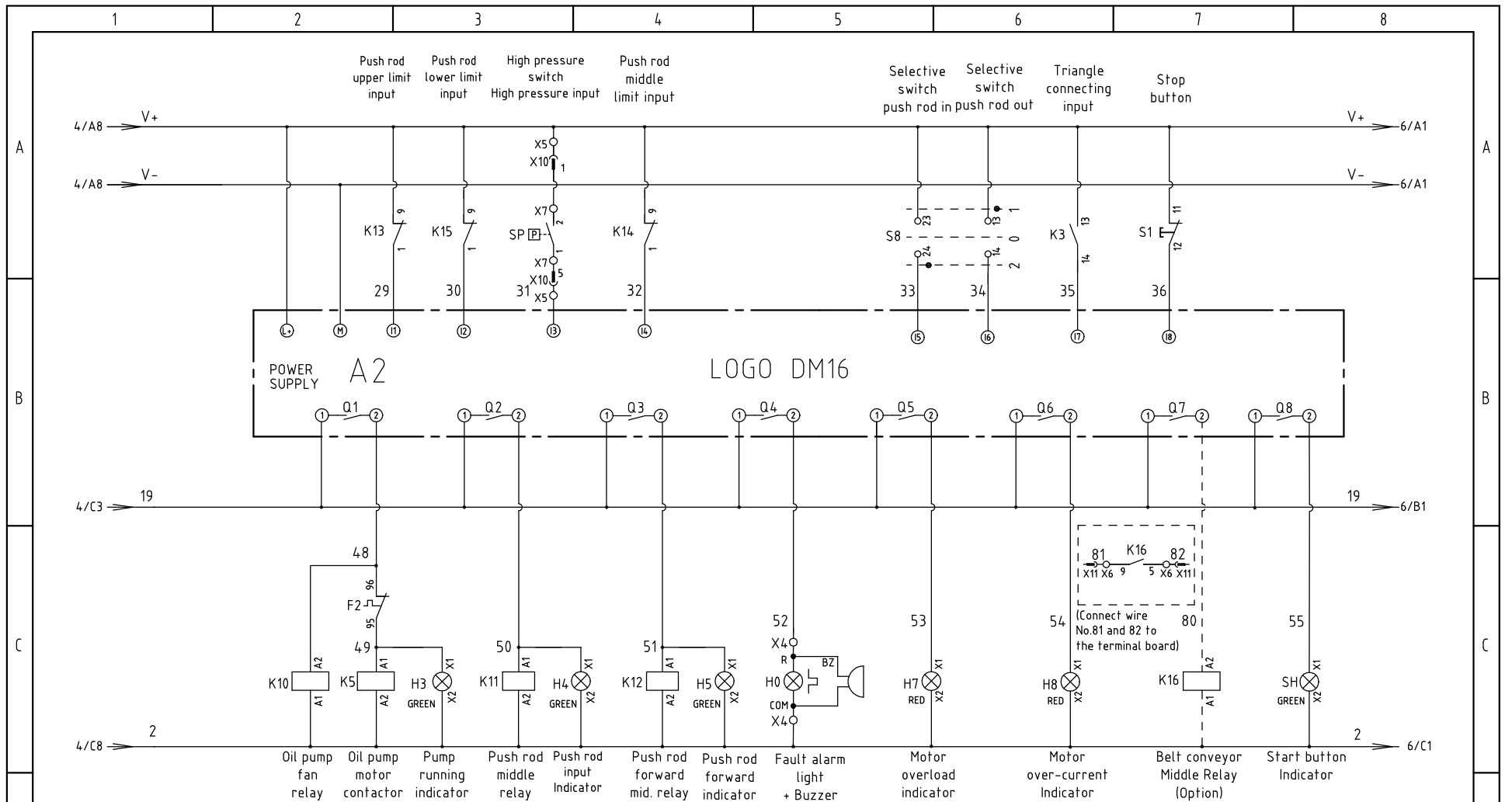

机型版本 Ver.D

					制图	叶健	版号	G
					设计	叶健	核	
					校对		准	
标记	更改前	更改后	更改人	日期	审核		日期	20211215

标题 SGS-75120S
控制电路图四

图号 SGS-75120S-CE-400V-G-5



信易電熱機械股份有限公司
Shini Plastics Technologies, Inc.

比例	第 5 张
标准	CE 共 11 张
机器电压	3Φ400V
机器频率	50Hz

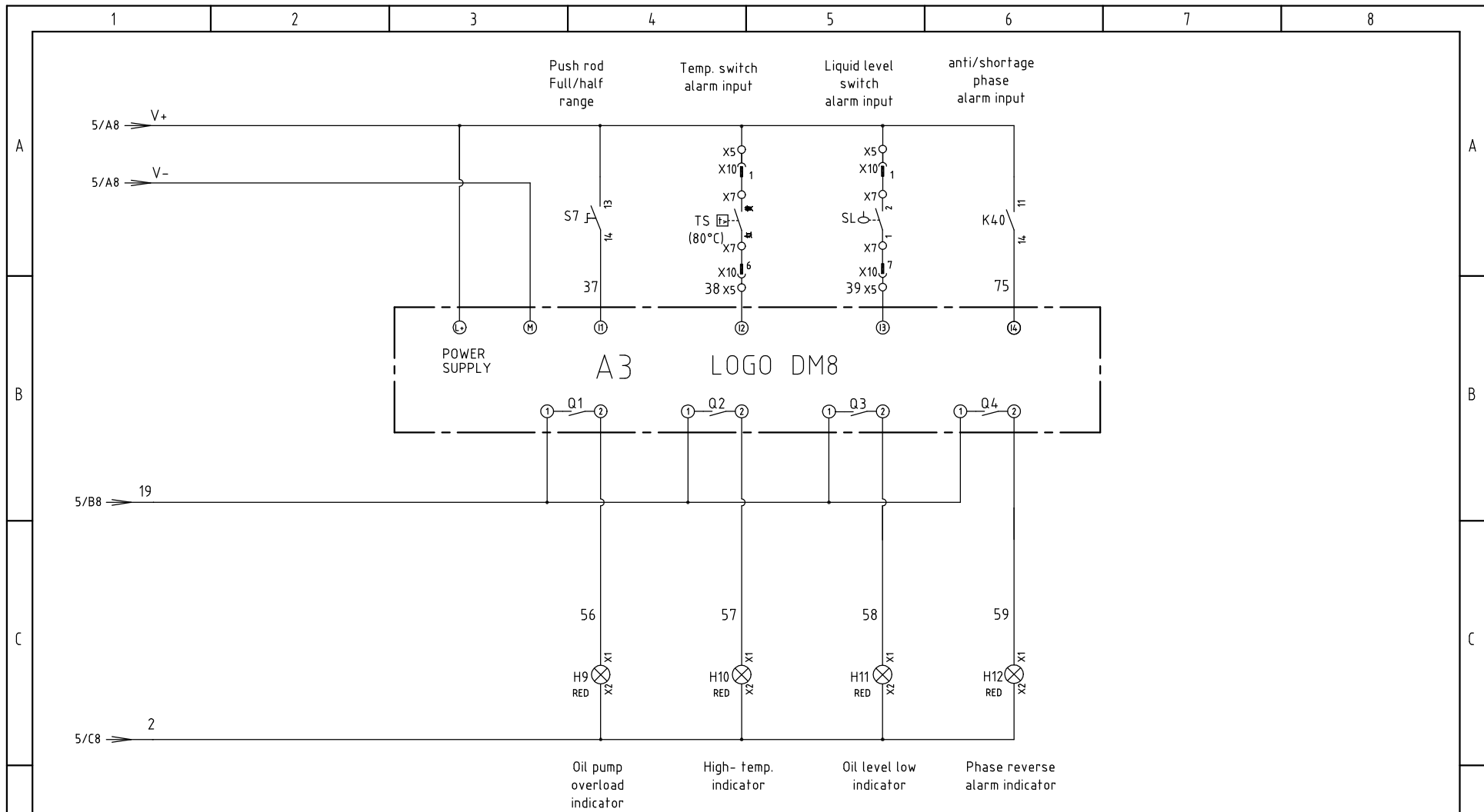

机型版本 Ver.D

					制图	叶健	版号	G
					设计	叶健	核	
					校对		准	
标记	更改前	更改后	更改人	日期	审核		日期	20211215

标题 SGS-75120S
控制电路图五

图号 SGS-75120S-CE-400V-G-6



信易電熱機械股份有限公司
Shini Plastics Technologies, Inc.

比例	第 6 张
标准 CE	共 11 张
机器电压	3Φ400V
机器频率	50Hz

1 2 3 4 5 6 7 8

A

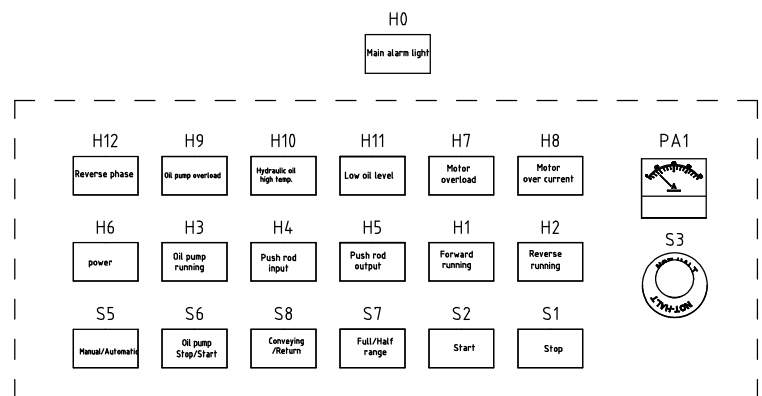

Control Panel Layout

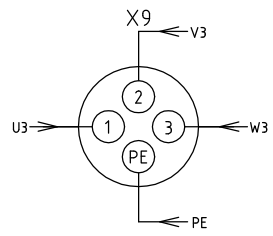

Anti-proof connector (connect to X8 terminal)

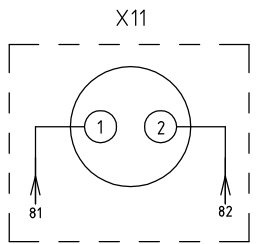

metal connector wiring connect to belt conveyor (option)

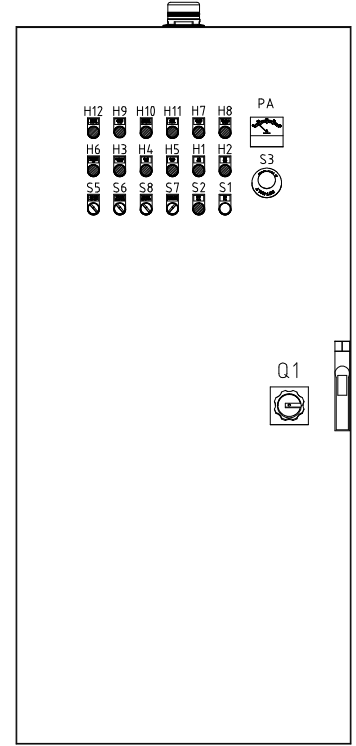

A

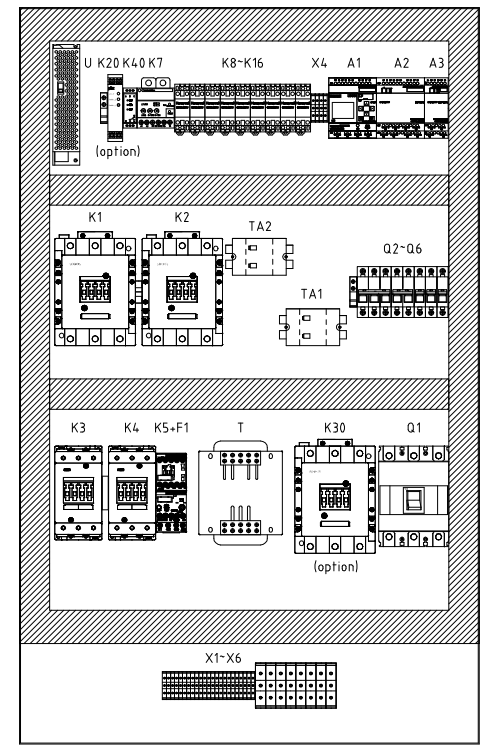

B

B

C

C

X6

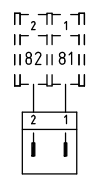

X11 2P metal connector (option)

X5

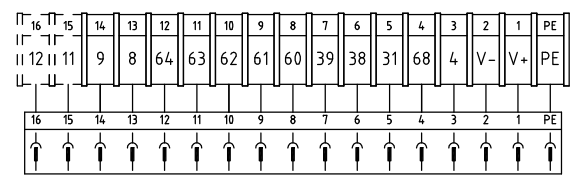

X10 16P heavy-duty connector (When safety relay is not selected, No. 9 is changed to No. 19)

X4

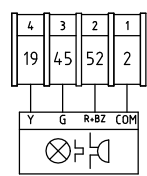

Alarm light red, yel, gre.

X3

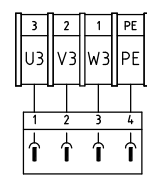

X9 water-proof connector

X2

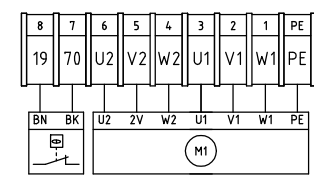

motor thermal protector cutting motor

X1

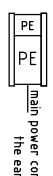

main power connected to the earth

机型版本 Ver.D

					制图	叶健	版号	G
					设计	叶健	核准	
					校对			
标记	更改前	更改后	更改人	日期	审核		日期	20211215

标题 SGS-75120S 电气元件布置图一 图号 SGS-75120S-CE-400V-G-7



信易电热机械股份有限公司 Shini Plastics Technologies, Inc.

比例	第 7 张
标准	CE 共 11 张
机器电压	3Φ400V
机器频率	50Hz

1 2 3 4 5 6 7 8

D

D

1 2 3 4 5 6 7 8

A

A

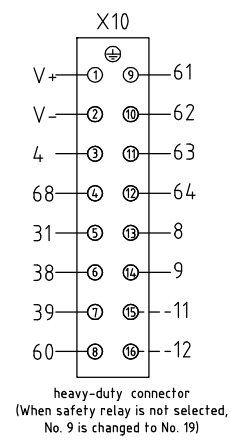

Note: 16P heavy-duty connector definition

Pin No.	Function	Description
1	DC24V(V+)	DC power common end
2	DC24V(V-)	
3	AC230V(zero wire)	
4	AC230V(fire wire)	Oil pump fan
5	DC24V power signal	pressure switch
6	DC24V power signal	temp. switch
7	DC24V power signal	liquid level switch
8	DC24V power signal	upper limit switch
9	DC24V power signal	middle limit switch
10	DC24V power signal	lower limit switch
11	DC24V power signal	conveying solenoid valve
12	DC24V power signal	return of material solenoid valve
13	AC24V power signal	safety switch
14	AC24V power signal	
15	AC24V power signal	
16	AC24V power signal	

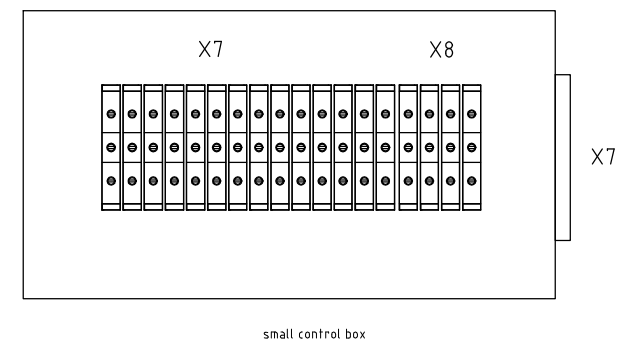

B

B

C

C

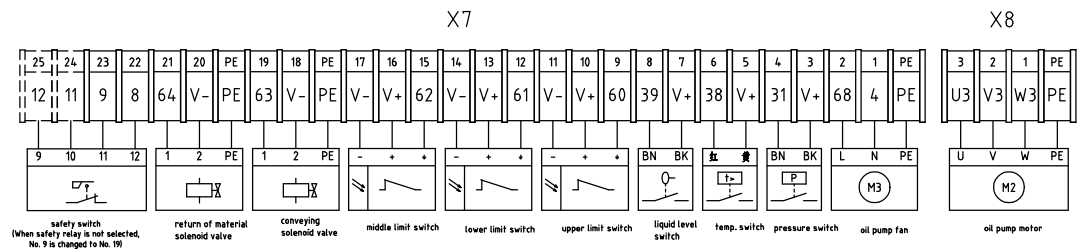

机型版本 Ver.D

					制图	叶健	版号	G	标题	SGS-75120S	图号	SGS-75120S-CE-400V-G-8	比例	第 8 张
					设计	叶健	核		电气元件布置图二				标准	CE 共 11 张
					校对		准		信易電熱機械股份有限公司 Shini Plastics Technologies, Inc.		机器电压		3φ400V	
标记	更改前	更改后	更改人	日期	审核		日期	20211215					机器频率	

1 2 3 4 5 6 7 8

D

D

1		2		3		4		5		6		7		8									
NO.	Symbol	Name		Manufacturer		Type		Specification		Number	Material number		Remark										
A	1	Q1	Breaker circuit breaker		ABB		A2B250TMF160		160A		1	YE41161500000											
	2	Q2	Circuit breaker		TECO		BM-63C		25A		1	YE40302503000											
	3	Q3	Circuit breaker		TECO		BM-63C/2006S		6A 2P		1	YE40200600000											
	4	Q4	Circuit breaker		TECO		BM-63C/1010S		10A 1P		1	YE40101000100											
	5	Q5	Circuit breaker		TECO		BM-63C/1003S		3A 1P		1	YE40100203000											
	6	Q6	Circuit breaker		TECO		BM-63C/1006S		6A 1P		1	YE40100600100											
	7	K1,K2	Contactor		SIEMENS		3RT5055-6AB36		24 VAC 50/60Hz		2	YE00505600100											
B	8	K3	Contactor		SIEMENS		3RT5045-1AC20		24 VAC 50/60Hz		1	YE00504502600											
	9	K4	Contactor		SIEMENS		3RT5044-1AC20		24 VAC 50/60Hz		1	YE00504402600											
	10		Auxiliary contact		SIEMENS		3RH5921-1CA01		1NC		4	YE00592110100											
	11		Auxiliary contact		SIEMENS		3RH5921-1CA10		1NO		3	YE00592110000											
	12		Mechanical interlocking		SIEMENS		3RA1924-2B		S2/S3		1	YE00319200000											
	13		Mechanical interlocking		SIEMENS		3RA1954-2A		S6		1	YE90195401300											
	14		Connecting clip		SIEMENS		3RA1932-2D		S2/S3/S6		4	YE90193201300											
C	15	K5	Contactor		SIEMENS		3RT6017-1AB02		24 VAC 50/60Hz		1	YE00601702600											
	16	K6,K7	Current relay		Telemecanique		LT4706M7A		0.5-6A/220VAC		1	YE04470600600											
	17	K8~K12	Middle relay		Honeywell		GR-2C-AC24V		24 VAC		5	YE03022400300											
	18	K13~K15	Middle relay		WEIDMULLER		DRM270024LT		DC24V		3	YE03272400000											
	19	K16	Middle relay		Honeywell		GR-2C-AC24V		24 VAC		1	YE03022400300		(3)									
	20	K20	Safety relay		PILZ		PNOZ×2.8P		24 V AC/DC		1	YE04023000000		(2)									
	21	K30	Contactor		SIEMENS		3RT5055-6AB36		24 VAC 50/60Hz		1	YE00505600100		(2)									
	22	K40	Phase disorder relay		CHAOSHI		ABJ2-12W		380VAC 50/60Hz		1	YE03103800000											
	23	F1	Overload relay		SIEMENS		3RU6116-1HB0		5.5-8A		1	YE01160550000											
D	24	TA1 TA2	Current transformer		RATTO		RCT-35		150/5A		2	YE04150500000											
	25	PA	Ammeter		SFIM		DH-670		150/5A		1	YE25671500000											
	机型版本 Ver.D		Note: (1) Materials not in the control box; (2) Optional relay options; (3) Belt conveyor options:																				
				制图		叶健		版号		G		标题		SGS-75120S		图号		SGS-75120S-CE-400V-G-9		比例		第 9 张	
				设计		叶健		核								标准		CE		共 11 张			
				校对				准															
标记		更改前		更改后		更改人		日期		20211215		 信易電熱機械股份有限公司 Shini Plastics Technologies, Inc.		机器电压		3Φ400V							
														机器频率		50Hz							
1		2		3		4		5		6		7		8									

1		2		3		4		5		6		7		8										
NO.	Symbol	Name		Manufacturer		Type		Specification		Number	Material number		Remark											
26	T	Transfarmer		BAIYUN		IN=400V/415V OUT=24V/230V		350VA/1500MA		1	YE70040008000													
27	U	DC Power		MEAN WELL		HRP-150-24		24V3.2A		1	YE71246500000													
A	28	A1	LOGO host module		SIEMENS		LOGO! 24RCE(with display)		24V AC/DC		1	YE80105200000												
	29	A2	LOGO extension module		SIEMENS		LOGO! DM16 24R		6ED1055-1NB10-0BA2		1	YE81105500100												
	30	A3	LOGO extension module		SIEMENS		LOGO! DM8 24R		6ED1055-1HB00-0BA2		1	YE81105500000												
	31	H0	3-color alarm light		SHINI		red. gre. yel.+buzzer		24VAC		1	BL90002401520		(1)										
	32	H1 ~ H6	Green indicator		ABB		CL2-502G		24VAC		6	YE83050200100		(1)										
	33	H7~ H12	Red indicator		ABB		CL2-502R		24VAC		6	YE83250200400		(1)										
B	34	S1	Stop button switch		SCHNEIDER		XB2BA22C		400VAC		1	YE11222000000		(1)										
	35	S2(H)	Start button switch		SCHNEIDER		XB2BW33B1C		24VAC/DC		1	YE11233100000		(1)										
	36		Button auxiliary contact		SCHNEIDER		ZB2BE101C		1NO		1	YE00210103100		(1)										
	37		Button auxiliary contact		SCHNEIDER		ZB2BE101C		1NO		1	YE00210103100		(1)(2)										
	38	S3	Emergency stop botton		SCHNEIDER		XB2BS542C		400VAC		1	YE11254200000		(1)										
	39		Button auxiliary contact		SCHNEIDER		ZB2BE102C		1NC		1	YE00210203100		(1)(2)										
	40		Emergency stop sign		SCHNEIDER		ZB2BY9330C		yellow botton with black letter		1	YE90293300000		(1)										
	41	S4	Safety swith		TEND		TZ-9212		AC-16		1	YE16921200000		(1)										
C	42	S5 S6 S7	Selective switch		ABB		C2SS2-10B-10		400V/5A		3	YE12210100000		(1)										
	43	S8	Selective switch		ABB		C3SS1-10B-20		400V/5A		1	YE12102000000		(1)										
	44	S11 S12 S13	Limit switch		SONON		SN12E06BPA		DC24V NPN		3	YE14126000000		(1)										
	45	X1	Terminal board		Honeywell		GK35PE		35mm ² PE		1	YE60003503500												
	46	X2	Terminal board		Honeywell		GK16		16mm ²		6	YE60001603200												
	47				Honeywell		GK16PE		16mm ² PE		1	YE60001603500												
	48				Honeywell		SK2.5		2.5mm ²		2	YE60002503200												
	49	X3	Terminal board		Honeywell		GK2.5PE		2.5mm ² PE		1	YE60002503400												
50				Honeywell		SK2.5		2.5mm ²		3	YE60002503200													
机型版本 Ver.D		Note: (1) Materials not in the control box; (2) Optional relay options; (3) Belt conveyor options:																						
D					制图		叶健		版号		G		标题		SGS-75120S		图号		SGS-75120S-CE-400V-G-10		比例		第 10 张	
					设计		叶健		核				电气元件明细表二				标准		CE		共 11 张			
					校对				准				 信易電熱機械股份有限公司 Shini Plastics Technologies, Inc.		机器电压		3Φ400V							
	标记		更改前		更改后		更改人		日期		20211215				机器频率		50Hz							
1		2		3		4		5		6		7		8										

