

SAL-810/820/830G

"Standard" Separate-vacuum Hopper Loader

Date: Feb., 2020

Version: Ver.B



Content

1. General Description	5
1.1 Coding Principle.....	6
1.2 Features.....	6
1.3 Technical Specifications	8
1.3.1 External Dimension	8
1.3.2 Specification	9
1.3.3 Loading Capacity.....	10
1.4 Safety Regulations.....	11
1.4.1 Safety Signs and Labels.....	11
1.4.2 Signs and Labels.....	11
2. Structure Characteristics and Working Principle.....	12
2.1 Working Principle.....	12
2.1.1 Working Principle	12
2.2 Options	15
3. Installation Layout.....	16
3.1 SAL-810G/820G/830G.....	16
3.2 Installation of Vacuum Hopper Receiver SMH Optional Storage Collective Hopper SCH-U.....	18
3.3 Installation of SAL-G Optional Proportional Valve	19
3.4 Installation of SAL-G Optional Cyclone Dust Separator.....	19
4. Operation	21
4.1 Panel Description.....	21
4.1.1 Parameter Setting	23
4.1.2 Communication Parameter Setting.....	25
4.2 Operation Procedure Description.....	26
4.2.1 Oeration procedure	26
4.2.2 Date Reset	26
4.3 Communication Parameter Table (Protocol modbus-RTU).....	27
5. Troubleshooting	30
6. Maintenance.....	31
6.1 Hopper Cleaning.....	31

6.2 Main Body Cleaning.....	32
6.3 Maintenance Schedule	33
6.3.1 About the Machine	33
6.3.2 Installation & Inspection	33
6.3.3 Daily Checking	33
6.3.4 Weekly Checking.....	33
6.3.5 Monthly Checking.....	33

Table Index

Table 1-1: Specification	9
--------------------------------	---

Picture Index

Picture 1-1: External Dimension 1	8
Picture 1-2: Loading Capacity	10
Picture 2-1: Working Principle 1	12
Picture 2-2: Working Principle 2	13
Picture 2-3: Working Principle 3	14
Picture 3-1: Installation Layout 1	16
Picture 3-2: Installation Layout 2	17
Picture 3-3: Optional SCH-U Installation Layout.....	18
Picture 3-4: Optional SPV-U Installation Layout	19
Picture 3-5: Optional ACF-1 Installation Layout.....	19
Picture 4-1: Panel.....	21
Picture 6-1: Hopper Cleaning	31

1. General Description



Please read through this operation manual before using and installation to avoid damage of the machine and personal injuries.



SAL-810G&SMH-6L

1.1 Coding Principle

SAL - xxx G - xx

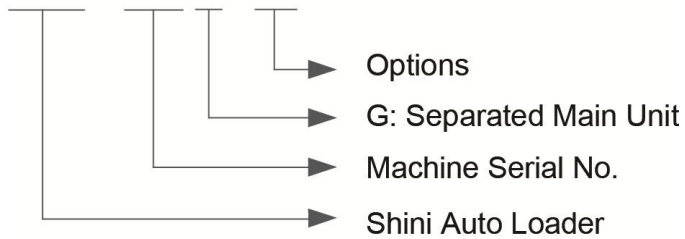

1.2 Features

- I Microprocessor for ease of use and has multiple alarm indicators.
- I Motor overload protector ensures long service life of motor.
- I Audible material shortage alarm.
- I Filter designed for easy cleaning and has filter status checking window for easier monitor of filter condition.
- I RS485 communication interface.
- I SPV-U and SBU can be controlled

All maintenance work should be carried out by a person with technical training or corresponding professional experience. The manual contains instructions for both operating and maintenance. Chapter 6 contains maintenance instructions for service engineers. Other chapters contain instructions for the daily operator.

Any modifications of the machine must be approved by SHINI in order to avoid personal injury and damage to machine. We shall not be liable for any damage caused by unauthorized change of the machine.

Our company provides after-sales service. Should you have any problem during using the machine, please contact the company or the local vendor.

Headquarter and Taipei factory:

Tel: + 886 (0)2 2680 9119

Shini Plastics Technologies (Dongguan), Inc:

Tel: + 86 (0)769 8111 6600

Email: shini@shini.com

Shini Plastics Technologies India Pvt.Ltd.:

Tel: + 91 250 3021 166.

1.3 Technical Specifications

1.3.1 External Dimension

SMH

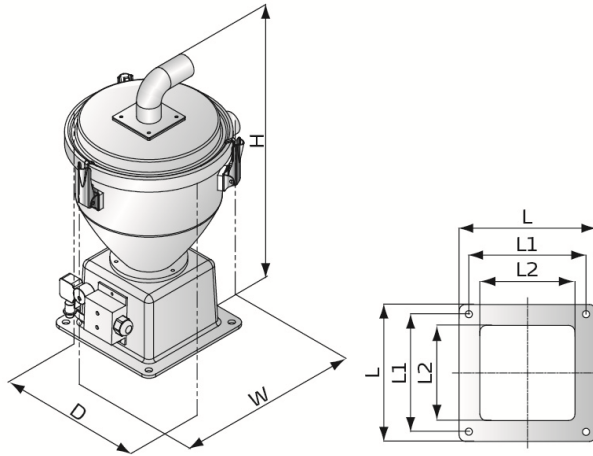

L=210mm

L1=180mm

L2=148mm

SVH

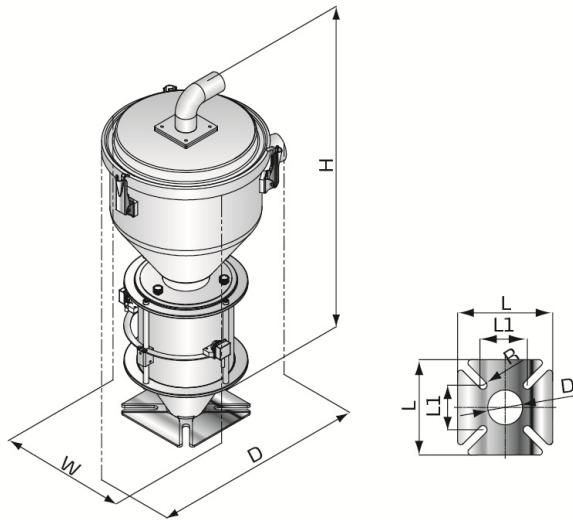

Picture 1-1: External Dimension 1

Models	L(mm)	L1(mm)	D(mm)	R(mm)
SVH-6L	150	70	55	6.5
SVH-12L	180	80	55	6.5

SAL-810G/820G/830G (Main controller)

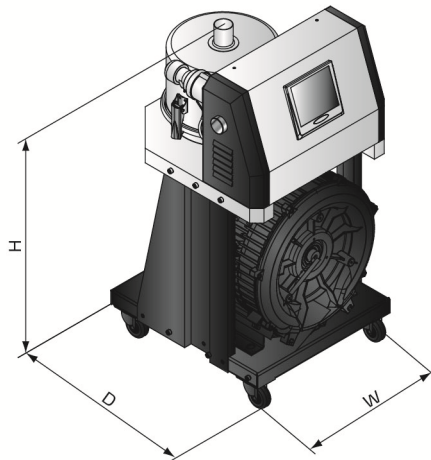

1.3.2 Specification

Table 1-1: Specification

Model	Ver.	Motor Type	Main Unit			Hopper Receiver(s)				RS-485 communication function	Conveying Hose Dia. (Inch)	Air Suction Pipe Dia. (Inch)	Conveying Capacity (kg / hr)
			Motor Power (kW) (50/60Hz)	Dimensions (mm)H×W×D	Weight (kg)	Recommended Model	Hopper Capacity (L)	Dimensions (mm) H×W×D	Weight (kg)				
SAL-810G	A	Induction	0.75(3Φ)	740×400×410	58	SMH-6L	6	460×260×315	6	●	1.5	1.5	300
						SVH-6L		600×285×305	7				
						SHR-6U		420×285×360	6				
SAL-820G	A	Induction	1.5(3Φ)	740×400×410	65	SMH-12L	12	515×300×350	7	●	1.5	1.5	480
						SVH-12L		695×300×360	11				
						SHR-12U		470×315×400	7				
SAL-830G	A	Induction	1.85(3Φ)	785×400×410	68	SMH-24L	24	720×325×375	9	●	2	2	700
						SVH-24L		1120×360×375	13				
						SHR-24U		690×315×400	9				

Notes: 1) "SVH" stands for photosensor hopper receiver; "SMH" stands for vacuum hopper receiver. "SHR-U" stands for Euro-Hopper receiver.

2) Test condition of conveying capacity: Plastic material of bulk density 0.65kg/L, dia. 3~5 mm, vertical conveying height: 4m, horizontal conveying distance: 5m.

3) "●" stands for standard, "○" stands for options, "-" stands for none.

4) All SAL-810G/820G/830G hoppers adopt the 4P heavy-duty connector.

5) Power supply: 3Φ, 230/400/460/575V, 50/60Hz.

1.3.3 Loading Capacity

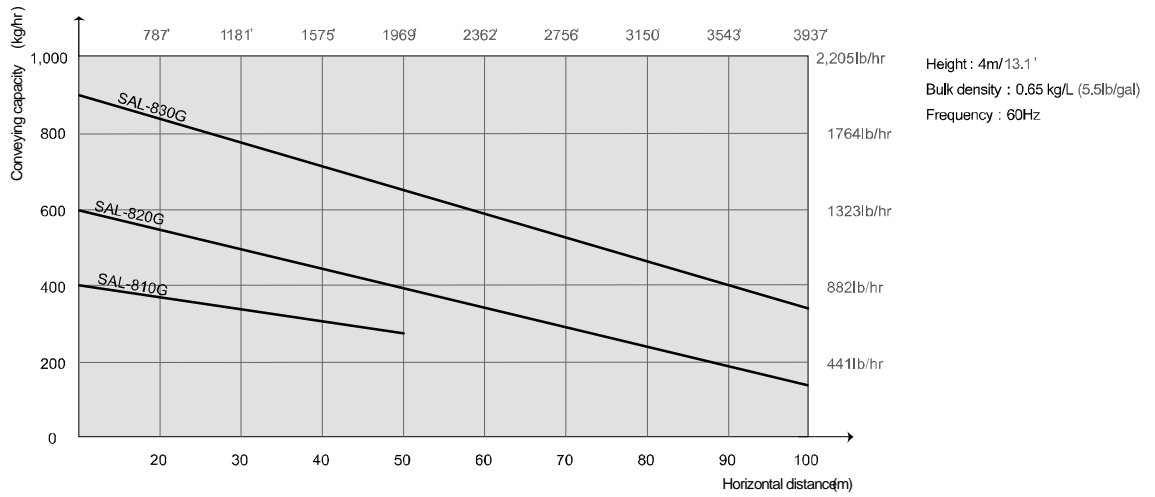

Picture 1-2: Loading Capacity

1.4 Safety Regulations

Please abide by the safety guide when you operate the machine so as to prevent damage of the machine and personal injuries.

1.4.1 Safety Signs and Labels



All electrical components should be installed by qualified electricians.
Turn off main switch and control switch during repair and maintenance.



Warning! High voltage!

This mark is attached on the cover of the control box.



Warning! Be careful!

Be more careful when this mark appears.



Attention!

No need for regular inspection because all the electrical parts in the control unit are fixed tightly!

1.4.2 Signs and Labels

 <p>Please clean the suction filter regularly YPS14-3000200</p>	<ol style="list-style-type: none">1. Please clean the suction filter regularly to avoid clogging and ensure proper loading capacity and long life span.2. The one year warranty does not cover the suction filter, please clean the filter carefully.
--	--

2. Structure Characteristics and Working Principle

2.1 Working Principle

SAL-G series are suitable for conveying plastic granules over long distance. Utilizing high efficiency vacuum blower to produce vacuum in material hopper, plastic materials will then be fed into material hopper by air pressure.

2.1.1 Working Principle

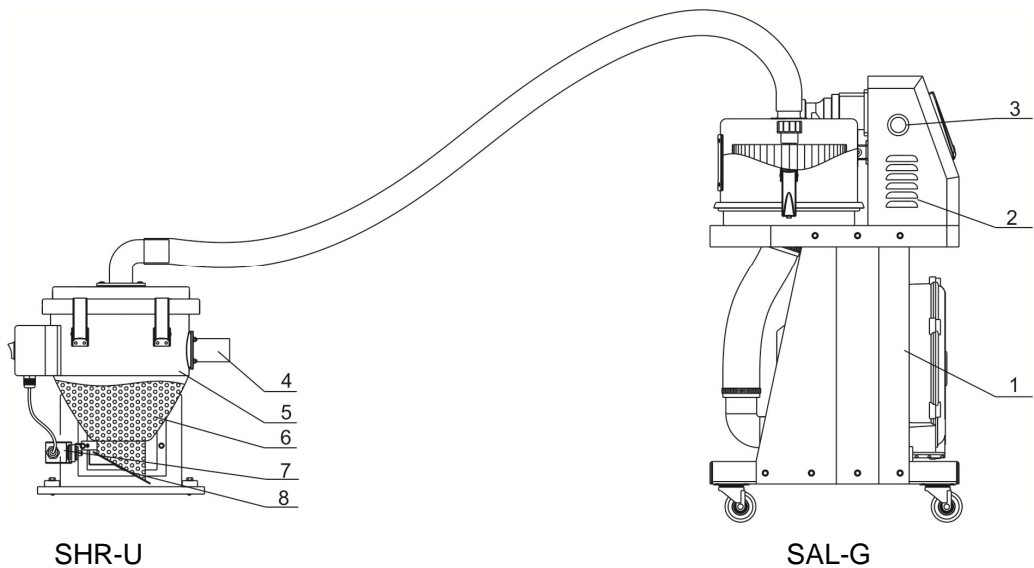

Picture 2-1: Working Principle 1

- | | |
|-------------------------|------------------------|
| 1. High-pressure blower | 2. Control box |
| 3. Buzzer | 4. Material inlet pipe |
| 5. Storage hopper | 6. Materials |
| 7. Reed switch | 8. Discharging plate |

Turn on the machine, the high pressure blower(1)starts work, it makes storage hopper (5) generate the vacuum. Discharging plate(8) closed, materials in silo get into the storage hopper(5) through material inlet pipe(4) by air pressure. When the loader finishes the work, high pressure blower(1) stop working, materials (6) will drop off due to gravity. When the reed switch (7) detects there's no material, high pressure blower (1) will start working again. When the loader can't suck the material or material shortage, the buzzer(3) on control box(2) will alarm.

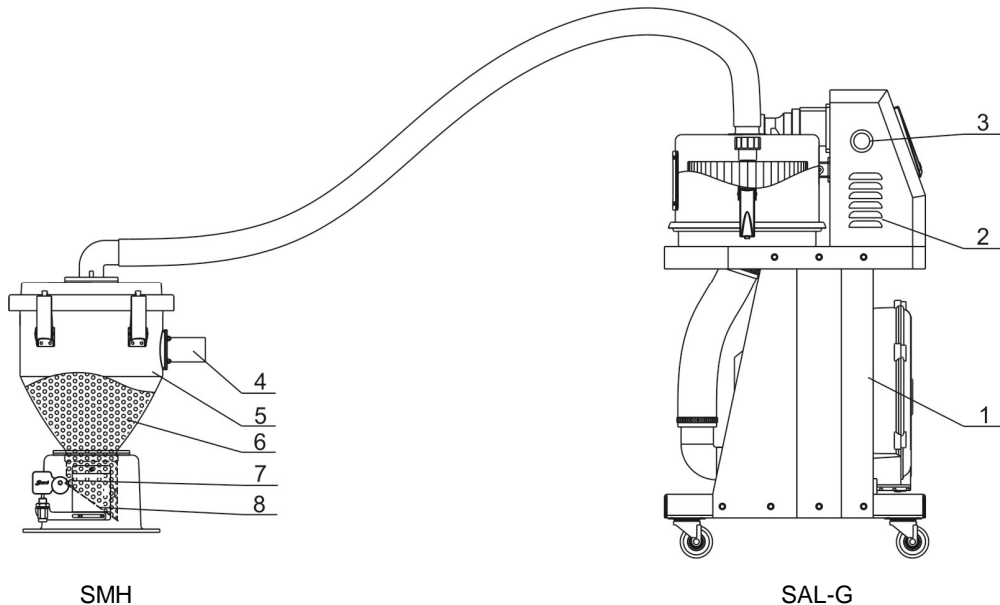

Picture 2-2: Working Principle 2

- | | |
|-------------------------|------------------------|
| 1. High-pressure blower | 2. Control box |
| 3. Buzzer | 4. Material inlet pipe |
| 5. Storage hopper | 6. Materials |
| 7. Micro switch | 8. Discharging plate |

When the machine is on, the high pressure blower(1) starts to work, and it makes storage hopper(5) generate the vacuum. The discharging plate(8) is closed, and then materials in silo get into the storage hopper(5) through material inlet pipe(4) owing to air pressure. When the loader finishes its work, high pressure blower(1) stops working, and materials(6) will drop off because of gravity. When the micro switch(7) detects there's no material, high pressure blower(1) will start to work again. When the loader can't suck the material or there is material shortage, buzzer(3) on the control box(2) will sound an alarm.

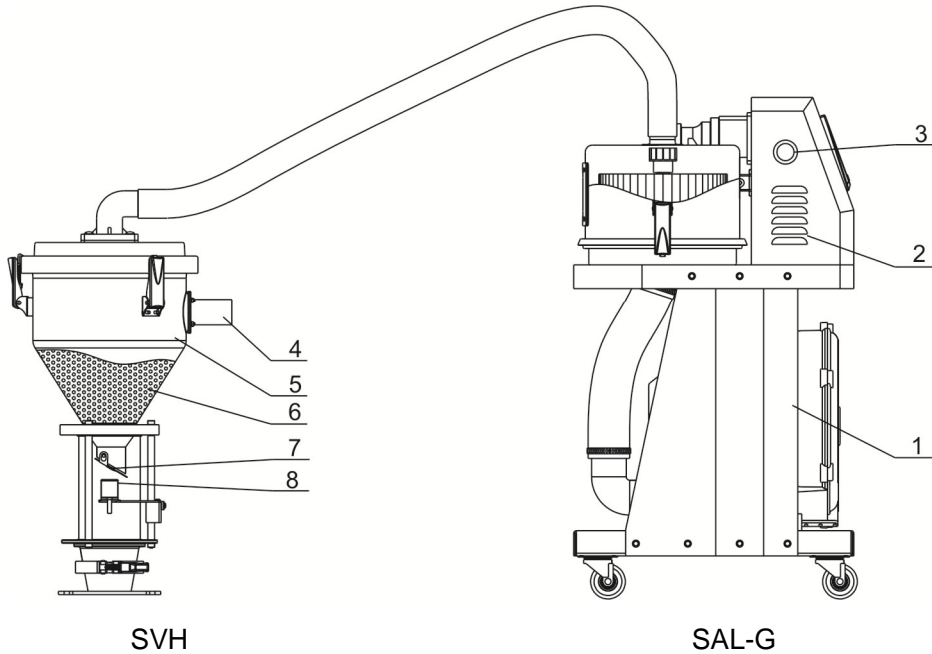

Picture 2-3: Working Principle 3

- | | |
|-------------------------|-------------------------|
| 1. High-pressure blower | 2. Control box |
| 3. Buzzer | 4. Material inlet pipe |
| 5. Storage hopper | 6. Materials |
| 7. Discharging plate | 8. Photoelectric switch |

When the machine is on, the high pressure blower(1) starts to work, and it makes storage hopper(5) generate the vacuum. The discharging plate(7) is closed, and then materials in silo get into the storage hopper(5) through material inlet pipe(4) owing to air pressure. When the loader finishes its work, high pressure blower(1) stops working, and materials(6) will drop off because of gravity. When the photoelectric switch(8) detects there's no material, high pressure blower(1) will start to work again. When the loader can't suck the material or there is material shortage, buzzer(3) on the control box(2) will sound an alarm.

2.2 Options

I Cyclone dust collector

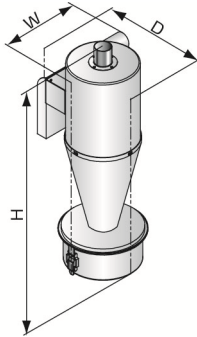

It is suggested to opt cyclone dust collector to reduce cleaning times of filter when regrind material occupies over 30% of total raw material.

Model	Capacity (H×W×D)	Pipe diameter (inch)
ACF-1	550×220×235	1.5
ACF-2	550×220×235	2.0

- I For SHR, SCH-6U/12U/24U and SICH-6U/12U/24U are optional (Temperature reduction is below 30°C within 30min).
- I SCH-U is optional for SMH, which is convenient for temporary storage of materials.
- I SPV-U (control box is included) is optional.
- I For polished hopper inside ones, add "P" at the end of the model code.

3. Installation Layout

3.1 SAL-810G/820G/830G

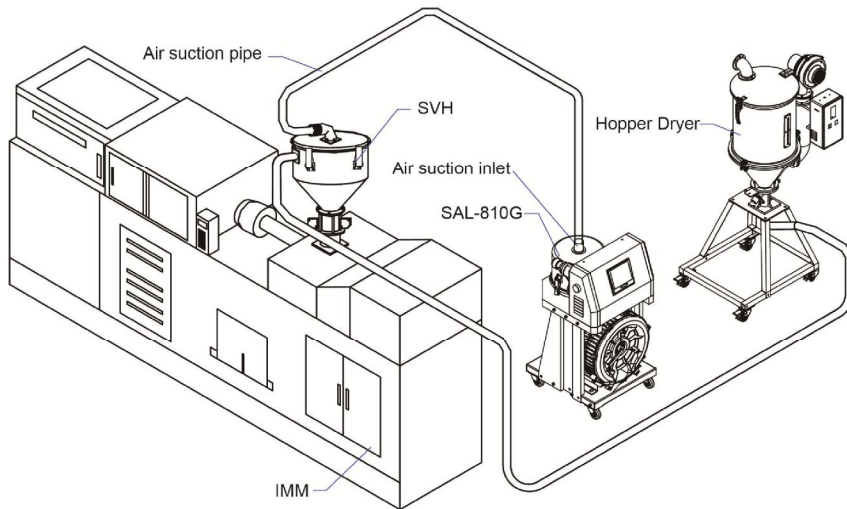

Picture 3-1: Installation Layout 1

Notes for Installation and Positioning:

- 1) Machine just can be mounted in vertical position. Make sure there's no pipe, fixed structure or other objects above the installing location and around the machine which may block machine's installation, hit objects or injure human person.
- 2) For easy maintenance, it's suggested to leave 1m space around the machine.
- 3) Machine should be placed on water-level surface. If it needs to be mounted on a higher surface (e.g. the scaffold or the interlayer), should ensure its structure and size could bear the weight and size of the machine.

Installation:

- 1) Place the SAL-810G/820G/830G machine at a proper position on the ground, connect the three phase power cord and the earth.
- 2) Install the material hopper on the top of the hopper dryer and the sensor hopper onto the plastic injection machine. Connect the signal cord to the machine SAL-810G/820G/830G.
- 3) Use the steel wire soft hose, connect the air inlets of the sensor hopper to the current air inlets of SAL-810G/820G/830G, then connect the material inlets of storage tank to the vacuum hopper.

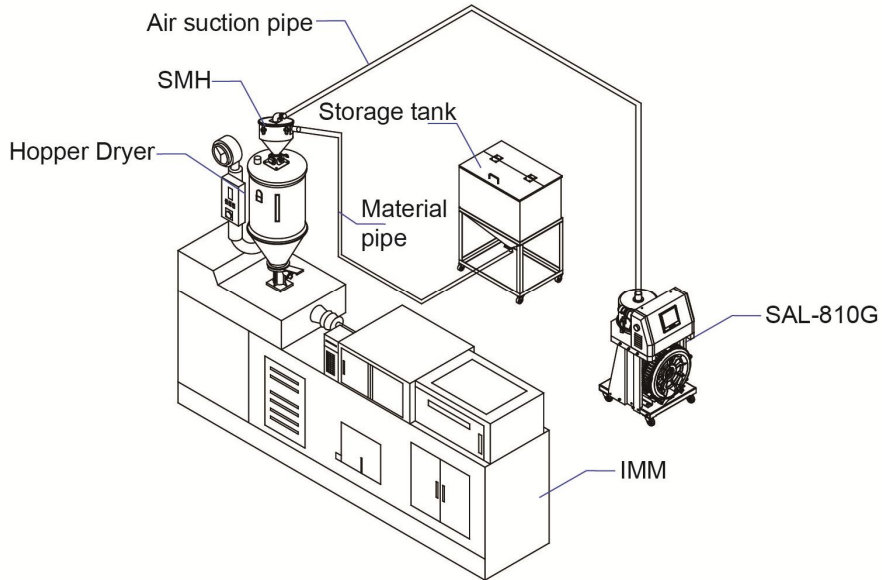

Picture 3-2: Installation Layout 2

Installation:

- 1) Place the machine SAL-810G/820G/830G at a proper position on the ground, connect the three phase power cord and the earth.
- 2) Install the material hopper on the top of hopper dryer, and connect the signal to the machine SAL-810G/820G/830G.
- 3) Use the steel wire hose, connect the air inlets of SMH to corresponding air inlets of SAL-810G/820G/830G. Then connect the other air inlets of SMH to the air inlets storage tank with hose .

3.2 Installation of Vacuum Hopper Receiver SMH Optional Storage Collective Hopper SCH-U

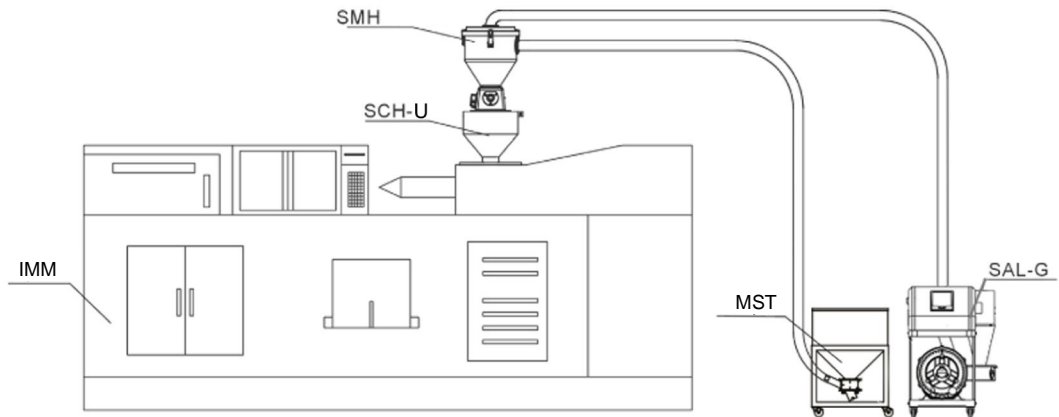

Picture 3-3: Optional SCH-U Installation Layout

SMH vacuum hopper can option with collection hopper SCH-U for direct mounting at material inlet of the molding machine.

Installation:

- 1) Mount the SCH-U at material inlet of molding machine, point to the holes and lock the screws.
- 2) Put the SMH on the SCH-U, point to the holes and lock the screws, then connect the signal wire to the hopper loader of SAL-G.
- 3) Connect the air inlet of vacuum hopper with steel wire hose separately to corresponding air inlet of SAL-G. Connect the material inlet of storage silo to the material inlet of vacuum hopper.

3.3 Installation of SAL-G Optional Proportional Valve

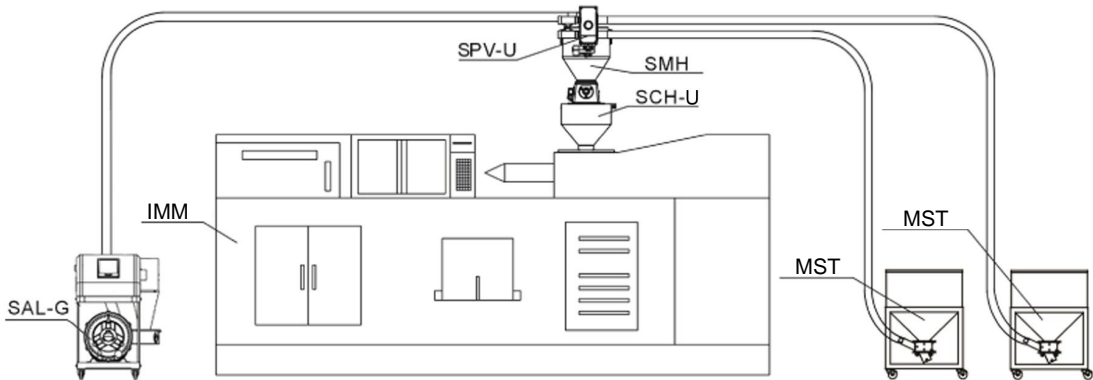

Picture 3-4: Optional SPV-U Installation Layout

Optional proportional valve SPV-U can realize two kinds of materials mixing.

Installation:

- 1) Mount the SPV-U at material inlet of SMH(SVH) lock up and fix the screws.
- 2) Put the SMH on SCH-6L or put the SVH at the material inlet of molding machine. Point to the holes and lock up the screws, then connect the signal wire to the hopper loader of SAL-G.
- 3) Connect the air inlet of vacuum hopper with steel wire hose separately to corresponding air inlet of SAL-G. Connect the material inlet of storage silo to the material inlet of vacuum hopper.

3.4 Installation of SAL-G Optional Cyclone Dust Separator

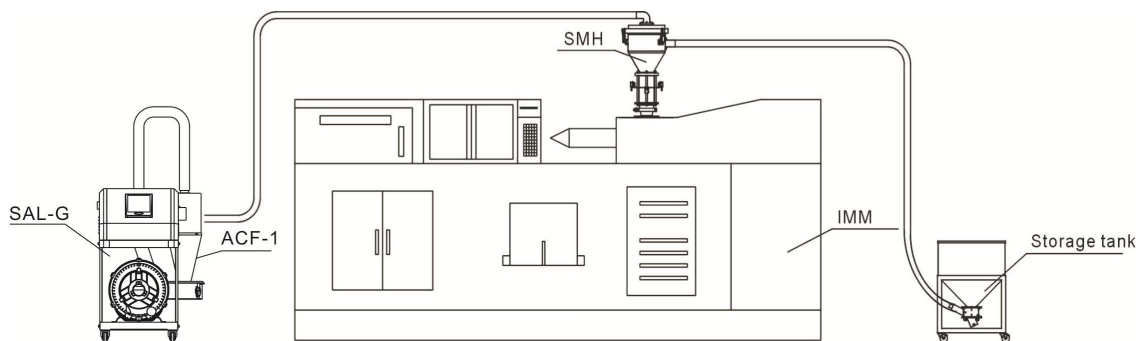

Picture 3-5: Optional ACF-1 Installation Layout

When conveying plastics contain dusts in high proportion, optional dust cyclone separator is recommended to reduce the purging times of main machine filter.

Installation:







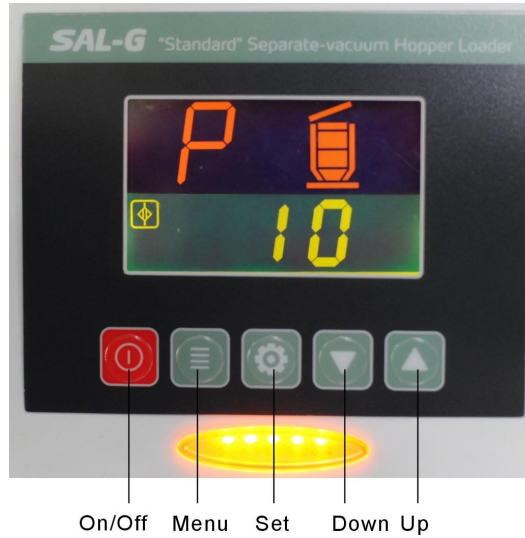

- 1) Mount the ACF-1 on coverplate of SAL-G and lock up the screws(There's two holes on coverplate of SAL-G main machine for installation);
- 2) Connect the air inlet of SAL-G main machine with steel wire hose to air outlet of ACF-1.
- 3) Connect the air inlet of ACF-1 with steel wire hose to air inlet of the hopper;
- 4) Connect one end of steel wire hose to hopper material inlet, and connect to the suction inlet of storage tank.

4. Operation

4.1 Panel Description



Picture 4-1: Panel

NO.	Symbol	Name	Description
1		ON/OFF	Start/stop the machine
2		MENU	Enter or exit parameter setting
3		SET	Modify or confirm machine parameters
4		DOWN	Move the menus down, and reduce the value
5		UP	Move the menus up, and increase the value
6		FULL MAT.LIGHT	It means full materials in the hopper
7		BLENDING	It means the machine is mixing the materials in the hopper
8		MAT.SHUT-OFF	It means the machine is shutting off the materials
9		SHORTAGE ALARM	It means machine alarm for no materials during suction
10		COMMUNICATION	It means the communication is connecting through
11		FILTER MESH CLEAN	It means filter auto cleaning function
12		OVERLOAD ALARM	It means motor overload error

4.1.1 Parameter Setting

Press **Menu key**, and enter parameter setting.

Step 1, Press “Up” and “Down” to select parameter, press “Set” to enter setting

Step 2, press “Up” and “Down” to adjust the parameters, press “Set” for confirmation and return to up page.

For example: set "suction action time" to 15 secs.

In OFF mode, press the <MENU> key to enter parameter setting.

Press <DOWN> or <UP> key to select the fuction code F.01, and press <SET> to enter.

Press the <DOWN> or <UP> key to modify the parameter to 15, and press the<SET> key to confirm the modification.

Code	Description	Parameters	
		Default Value	Adjusting Range
F.01	<p>Suction action time</p> <p>Motor suction action time whe it short of materials, which is also the action time of vacuum breaking valve.</p> <p>Corresponding action: D</p>	15 secs.	5-127 secs.
F.02	<p>Shut-off action time</p> <p>Start the same time with the suction action, and set the shut-off time. Set it to 0: not start.</p>	0	0-100 secs.
F.03	<p>Mixing proportion</p> <p>Start the same time with the suction action, and set the mixing proportion.</p> <p>Time calculation method: suction time *[F.03]%</p> <p>Set it to 0: not start.</p>	0% not start	0-100%
F.04	<p>Mixing working method</p> <p>When mixing happens, the layers of mixing action.</p> <p>For example, if the suction time is 20sec, the mixing proportion is 10%, and the layer number is 2, then the mixing action is 9s—1s ----9s---1s.</p> <p>Set single layer's working, and the suction time range is 5-99 secs.</p> <p>Set double layer's working, and the suction time range is 17-99 secs.</p> <p>Set three layer's working, and the suction time range is 32-99 secs.</p> <p>Set four layer's working, and the suction time range is 46-99 secs.</p> <p>If changing the suction time, by calculation, the minimum suction action of each layer is less than 1 sec., and the program will force the action changing time to 1 sec.</p>	1	1-4 times

F.05	Mixing count cycle start setting. Count since the first time start up, and start once mixing after repeatedly started several suction actions. Set it to 1: mixing in each suction. Set [F.03] to 0: Don't mix the materials.	1 time	1-9 times
F.06	Screen cleaing time setting before suction Set it to 0: no cleaning before suction Corresponding action: R01	0 secs.	0-99 secs.
F.07	Screen cleaing time setting after suction Set it to 0: no cleaning after suction Corresponding action: R11	0 secs.	0-99 secs.
F.08	Cleaning action cycle Start once [F.06] or [F.07] cleaning action after repeatedly started several suction actions. Set it to 1: Clean the screen after each suction	3 times	1-99 times
F.09	Suction cycle waiting time After once suction action, the waiting time before the next suction action. Set it to 0: Don't wait. Corresponding action: N03	0 (Unit 10 secs.)	0-9990
F.10	Shortage Times Count Alarm Set the times for the alarm that the material doesn't drop into the hopper before machine shutdown. Alarm cleaning method: 1.The alarm will dismiss when it sucked the materials again. 2.Press ENT key on the panel to cancel. 3.Turn on/off the power again. Set it to 9 to cancel the function. Corresponding action: A.01	3	1-9 times
F.11	Shortage Times Count Stop Alarm Set the times for the alarm that the material doesn't drop into the hopper before machine shutdown. Alarm cleaning method: 1.Press ENT key on the panel to cancel. 2.Turn on/off the power again. Corresponding action: A.04	3	[F.10]-99
F.12	The time to wait motor stop (suitable for SAL-430/460) After motor start running, it's necessary to wait the countdown time before the next action.	0 secs.	0-99 secs.
F.13	Alarm buzzer sound type 0:Lasting sound 1:Slow intermittent sound 2:Fast intermittent sound	0	0-2

F.14	<p style="text-align: center;">Motor delay stop time</p> <p>The delay time after [F.01] suction time is over, then the motor stops running.</p>	30 secs.	0~999 secs.
F.15	<p style="text-align: center;">Motor using time</p> <p>Check the motor using time and clear the motor using time. The method to clear motor using time: set the value to 0, and press ENT key to clear.</p>	0 (Unit: 10hrs)	0-999 Only 0 can clear the time;

4.1.2 Communication Parameter Setting

Press the <MENU> key and <UP> key at the same time for three seconds to enter the communication parameter setting screen.

Code	Function Description	Parameter Values	
		Default Value	Range
F.30	Communication address	1	1-99
F.31	<p style="text-align: center;">Communication baud rate</p> <p>0---19200 1---9600 2---4800</p>	1	0-2
F.32	<p style="text-align: center;">Parity check</p> <p>0---invalid 1---odd parity 2--- even parity</p>	0	0-2

4.2 Operation Procedure Description

4.2.1 Operation procedure

Panel Code	Function Description	Corresponding Parameters	Parameter Values	
			Default Value	Range
R01	Filter screen cleaning	F.06	3 secs.	0-99 secs.
R02	Wait for motor stop	F.12	3 secs.	0-99 secs.
D	Sucking materials (vacuum breaking valve works)	F.01	15 secs.	5-127 secs.
	Sucking master batch (The vacuum breaking valve closes after this action)	F.03	0%	0-100%
		F.05	3	1-9 times
N01	Waiting time	F.12	3 secs.	0-99 secs.
R11	Filter screen cleaning, and the materials discharge into the hopper	F.07	0 secs.	0-99 secs.
R12	Wait for motor stop	F.12	3 secs.	0-99 secs.
N02	Wait for materials completely discharge into the hopper	F.20	10 secs.	5-99 secs.
N03	Suction cycle waiting	F.09	0 secs.	0-9990 secs.
P	Wait for suction confirmation			

4.2.2 Date Reset

1. Turn off the machine power.
2. Short circuit two pins of J2.
3. Turn on the machine power.
4. Wait for three secs., and then remove the short-circuit two pins of J2.
5. Finished

Notes: All parameter settings will be reset to factory default. Please use this function carefully.

4.3 Communication Parameter Table (Protocol modbus-RTU)

Address (Keep the deposit area) (decimal system)	Parameter Content	Reading R/ Writing W	Default Paramet ers	Minimum	Maximum	Unit
0	Current action	R	/			/
	bit 0 shutdown			0	1	
	bit 1 standby			0	1	
	bit 2 suck the materials			0	1	
	bit 3 wait for material discharge			0	1	
	bit 4 clear the filter screen			0	1	
	bit 5 wait for material stop			0	1	
	bit 6 filter blockage alarm			0	1	
	bit 7 shortage alarm			0	1	
Bit 8~bit 16 defined						
1	Real-time information	R	/			/
3	Suction action time	R/W	15	5	127	S
4	Filter cleaning cycle	R/W	3	1	99	次
6	Filter setting time	R/W	0	0	99	S
7	Discharge check time	R/W	10	5	99	S
8	Standby time after motor running	R/W	0	0	99	S
9	Filter cleaning setting time after suction	R/W	0	0	99	S
10	Suction cycle waiting time	R/W	0	0	9990	10S
13	Input and output status	R	/			/
	bit 0 shortage input signal			0 full material	1 shortage of materials	
	bit 1 filter blockage input signal			0 no blockage	1 blocked	
	bit 4 suction output			0 no output	1 output	
	bit 5 spraying valve output			0 no output	1 output	
	bit 6 alarm output			0 no output	1 output	
	bit7~bit15 undefined					
14	Current action	R	/			/
	bit 0 shut down			0	1	
	bit 1 standby			0	1	
	bit 2 suck materials			0	1	
	bit 3 wait for material discharge			0	1	
	bit 4 clean the filter			0	1	
	bit 5 wait for motor stop			0	1	
	bit 6 filter blockage alarm			0	1	
bit 7 material shortage	0	1				

	alarm					
	bit8~bit15 undefined					
15	Start/stop control	W	/	0 start up	1 shut down	/
16	Suction action time	R/W	15	5	127	S
17	Mixing proportion	R/W	0	0	100	%
18	Set the start of mixing count cycle	R/W	1	1	9	time s
19	Filter cleaning cycle	R/W	3	1	99	time s
20	Suction cycle waiting time	R/W	0	0	9990	10S
21	Filter cleaning set time before suction	R/W	0	0	99	S
22	Filter cleaning set time after suction	R/W	0	0	99	S
23	Discharge check time	R/W	10	5	99	S
24	Shortage count alarm	R/W	3	1	9	time s
25	Shortage count stop alarm	R/W	3	Shortage count alarm	99	time s
26	Standby time after motor running	R/W	0	0	99	S
27	Buzzer sound type	R/W	1	0	2	/
29	Motor use time record	R/W	0	0	999	10h
30	Full material detection time	R/W	3	1	9	S
31	Shortage detection time	R/W	3	1	9	S
32	Shut-off time	R/W	0	0	100	S
34	Motor delay stop time	R/W	30	0	999	S
35	Total numbers of mixing actions	R	0	0	0x03 set value	time s
36	Total numbers of cleaning actions	R	0	0	0x04 set value	time s
37	Total numbers of shortage alarm	R	0	0	99	time s
38	On/off control	W		0 start up	1 shut down	/
39	Current action	R	/			/
	bit 0 start			0	1	
	bit 1 standby			0	1	
	bit 2 filter cleaning			0	1	
	bit 3 wait for motor stop			0	1	
	bit 4 suck materials			0	1	
	bit 5 suck master batch (mixing)			0	1	
	bit 6 wait for material discharge			0	1	
	bit 7 suction cycle waiting time			0	1	
bit8 ~bit 15 undefined						
40	Real-time info.	R	/			/
41	Input and output state	R	/			/
	bit 0 shortage input signal			0 full material	1 shortage of materials	

	bit 1 filter blockage input signal			0 no blockage	1 blocked	
	bit 2 suction output			0 no output	1 output	
	bit 3 vacuum breaking output			0 no output	1 output	
	bit 4 mixing output			0 no output	1 output	
	bit 5 spraying valve output			0 no output	1 output	
	bit 6 alarm output			0 no output	1 output	
	bit7~bit15 undefined					
42	Alarm status	R	/			/
	bit 0 shortage alarm			0	1	
	bit 1 shortage stop alarm			0	1	
	bit 2 filter blockage alarm			0	1	
	bit 3~bit 15 undefined					
45	Mixing layers	R/W	1	1	4	layer
46	Action mode (Only can be set in shutdown)	R/W	5	1	5	/

Notes: R means only reading
W means only writing
R/W means reading/writing

Notes: There's no password set in factory before delivery, and it can be set by the customer. In case of loss, please contact us.

5. Troubleshooting

Fault	Possible reasons	Solutions
When shortage lasts long, and suction blower don't run.	The main switch and control switch don't open or the above two don't connect well.	Close the main switch and control switch and check their connecting.
	The microswitch on hopper don't connect well .	Adjust or replace.
	The signal wire is break off.	Re-connect.
The suction blower still running when the hopper is full.	The touch point is conglutinated	Repair or replace.
After several times of loading the material hopper still empty or the material shortage alarms.	The storage tank is empty.	Add the material
	The pipe is air leak.	Lock tightly and replace the vacuuming pipe.
	The filter is blocked.	Clean the filter.
The motor can't run.	Short-phase or motor was burnt out.	Check and replace.
The fuse always burnt out after start-up.	Short circuit or connect the ground.	Check the circuit.
Motor overload alarms	The filter is blocked.	Clean the filter and reset the overload relay.
	One of three phase is lacking.	Check the circuit and reset the overload relay.kkk
Poor material liquidityin the pipe	Over or lack of air quantity	Adjust air inlet location of the suction box. Avoid small bending of the elbow.

6. Maintenance

6.1 Hopper Cleaning

SMH Cleaning: In order to avoid air-blocking and to get smooth conveying.

Clean the filter screen inside of material hopper. Unlock the snap hook on the hopper, remove the hopper cover and take out the filter screen, then clean it. Clean the filter periodically or when the suction force is reduced.

SVH Cleaning:

1. Clean the filter screen, in order to avoid air-blocking and to get smooth conveying. Clean the filter screen inside of material hopper. Unlock the snap hook on the hopper, remove the cover and take out the filter, then clean it. Clean periodically or when the suction force is reduced.
2. Clean the glass pipe, when the dust accreted on the tube. Clean the dust in time for machine normal working.

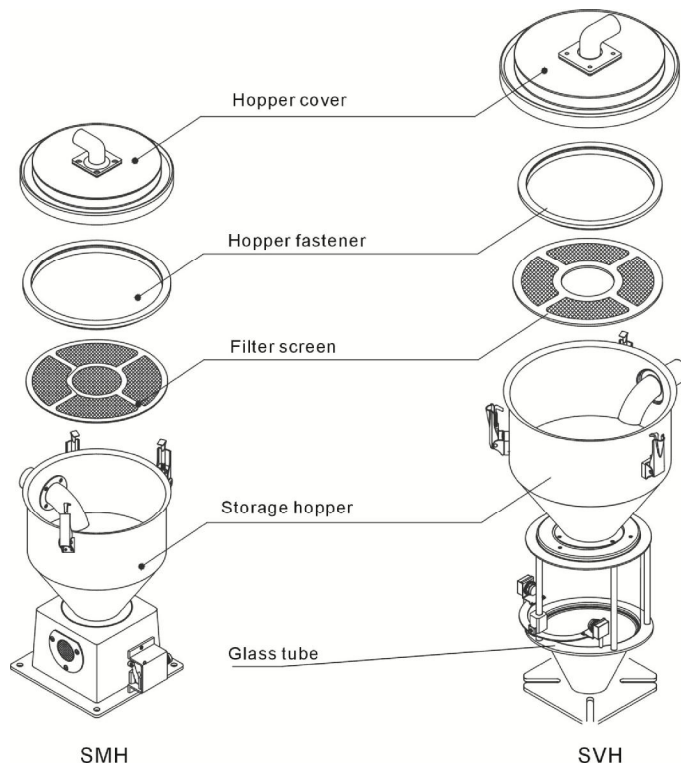

Picture 6-1: Hopper Cleaning

6.2 Main Body Cleaning

When machine in use, clean the filter periodically or when the suction force is reduced. Take out the filter from the main body, clean the dust accreted on it to ensure good ventilation of the air and to enhance loading capacity.

Filter Inspection and Storage Hopper Cleaning

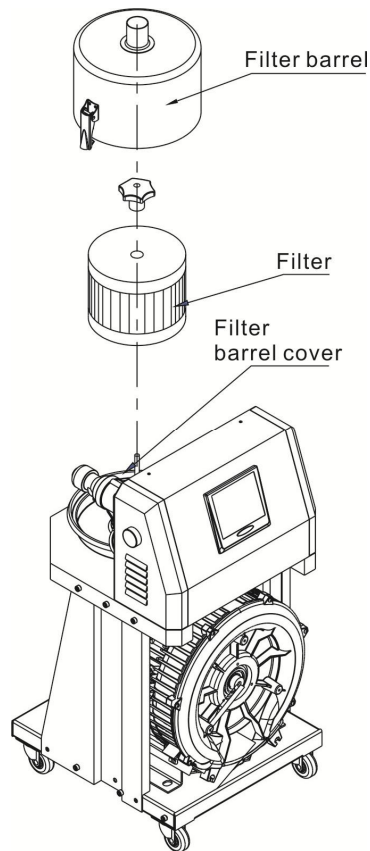

SAL-800G

1. Loosen the snap hook, take out the filter barrel and the filter; blow off the dust with a high-pressure air gun from the inside to outside; take down the filter barrel cover and remove the dust in it.
2. Clean the filter. Period: daily

6.3 Maintenance Schedule

6.3.1 About the Machine

Model _____ SN _____ Manufacture date _____

Voltage _____ Φ _____ V Frequency _____ Hz Power _____ kW

6.3.2 Installation & Inspection

- Check if the suction pipe has been correctly connected.
- Check if that pipe clips is secured.
- Check if mounting base is secured.

Electrical Installation

- Voltage: _____ V _____ Hz
- Fuse: One-phase: _____ A Three-phase: _____ A
- Check power phase.

6.3.3 Daily Checking

- Check main power switch.
- Check filter
- Check working status of the blower.

6.3.4 Weekly Checking

- Check all the electrical cables.
- Check if there are loose connections of electrical components.
- Check the screw of the base is secured.
- Check the air filter.

6.3.5 Monthly Checking

- Check the spring lock on the hopper cover is loosed or not.
- Check the hopper flap is deformed or not.
- Check the performance of magnetic proximity switch/photoelectrical sensor.