

SIC-W-EB

Budget Water-cooled Water Chillers

Date: Dec. 2023

Version: Ver.B (English)



Contents

1. General Description	5
1.1 Coding Principle.....	6
1.2 Features.....	6
1.3 Technical Specifications	8
1.3.1 External Dimensions.....	8
1.3.2 Specification List.....	9
1.4 Safety Regulations.....	10
1.4.1 Security Labels.....	10
1.4.2 Signs and Labels.....	11
1.5 Exemption Clause.....	12
2. Structural Features and Working Principle.....	13
2.1 Main Functions.....	13
2.1.1 Working Principle.....	13
2.1.2 Main Parts and Functions.....	14
3. Installation and Debugging	17
3.1 Machine Positioning.....	17
3.2 Pipeline Connection	17
3.3 Power Connection.....	18
3.4 Water Tank Filling.....	19
4. Application and Operation.....	20
4.1 Control Panel	20
4.2 Machine startup	22
4.3 Machine Shutdown	23
4.4 Temperature Controller.....	23
4.4.1 Temperature Setting Method.....	24
4.4.2 Factory Parameters Setting Table.....	24
5. Trouble-shooting.....	26
6. Maintenance and Repair	28
6.1 Fill in the Refrigerant.....	30
6.2 Components Maintenance	31
6.2.1 Condenser.....	31

6.2.2	Evaporator.....	32
6.3	Maintenance Schedule	34
6.3.1	About the Machine.....	34
6.3.2	Check after Installation	34
6.3.3	Daily Checking	34
6.3.4	Weekly Checking.....	34
6.3.5	Montly Checking.....	34
6.3.6	Trimonthly Checking.....	34
6.3.7	Half-yearly Checking	35
6.3.8	Yearly Checking	35
6.3.9	3 year Checking	35

Table Index

Table 1-1:	Specifications	8
Table 1-2:	Specification List	9
Table 4-1:	Specification of Control Panel	20
Table 4-2:	Factory Parameters Setting Table.....	24
Table 4-3:	Alarm List	24
Table 6-1:	SIC-W-EB Filling Quantity	31

Picture Index

Picture 1-1:	Budget Water-cooled Water Chillers SIC-10W-EB	5
Picture 1-2:	Outline Dimensional Drawing	8
Picture 2-1:	Working Principle Diagram.....	13
Picture 2-2:	Compressor.....	14
Picture 2-3:	Condenser.....	14
Picture 2-4:	Drying Filter.....	15
Picture 2-5:	Throttling Capilliary	15
Picture 2-6:	Evaporator.....	16
Picture 2-7:	High and Low Pressure Controller	16
Picture 3-1:	Installation Location	18
Picture 4-1:	Control Panel	20

Picture 4-2: ON/OFF.....	22
Picture 4-3: Temperature Controller.....	23
Picture 6-1: Fill in the Refrigerant.....	30

1. General Description



Please read through this operation manual before using and installation to avoid damage of the machine and personal injuries.

SIC-W-EB series are applicable for cooling moulds to reduce products molding cycle time; also they are available in the cooling of equipments in order to maintain a normal temperature. Besides, they are suitable for other industries with the need of cooling.



Picture 1-1: Budget Water-cooled Water Chillers SIC-10W-EB

1.1 Coding Principle

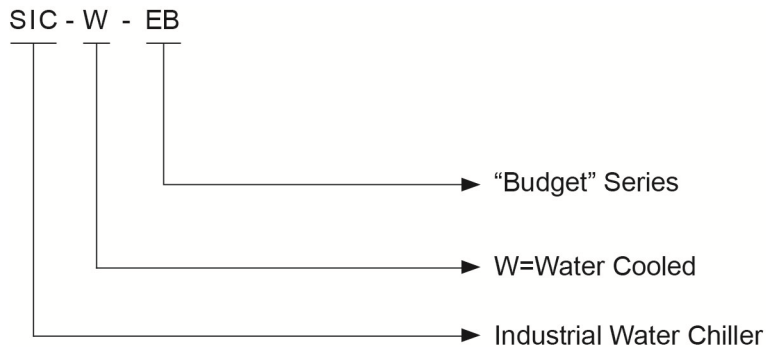

1.2 Features

- 1) Cooling range 7~35°C.
- 2) The eco-friendly insulated water tank has extended service life and is contamination-free.
- 3) Adopt R410 A refrigerant with good refrigeration effect.
- 4) Refrigeration loop controlled by high and low pressure switches for accurate detection of system pressure.
- 5) Compressor and pump overload protection.
- 6) Shell and tube condenser with quick heat conduction and good dissipation effect.
- 7) Adopt tube and shell evaporator. The SUS304 pipe is directly mounted on water tank that is economical and practical.
- 8) Adopt renowned brand of original precision temperature-controlled meter with an accuracy of $\pm 0.1^{\circ}\text{C}$.

All service work should be carried out by a person with technical training or corresponding professional experience. The manual contains instructions for both handling and servicing. Chapter 7, which contains service instructions intended for service engineers. Other chapters contain instructions for the daily operator.

Any modifications of the machine must be approved by SHINI in order to avoid personal injury and damage to machine. We shall not be liable for any damage caused by unauthorized change of the machine.

Our company provides excellent after-sales service. Should you have any problem during using the machine, please contact the company or the local vendor.

Shini Hotline Service:

Headquarter and Taipei factory:

Tel: + 886 (0)2 2680 9119

Shini Plastics Technologies (Dongguan), Inc.:

Tel: +86 (0)769 8331 3588

Shini Plastics Technologies (Pinghu), Inc.:

Tel: +86 (0)573 8522 5288

Shinden Precision Machinery (Chongqing), Inc.:

+86 (0)23 6431 0898

1.3 Technical Specifications

1.3.1 External Dimensions

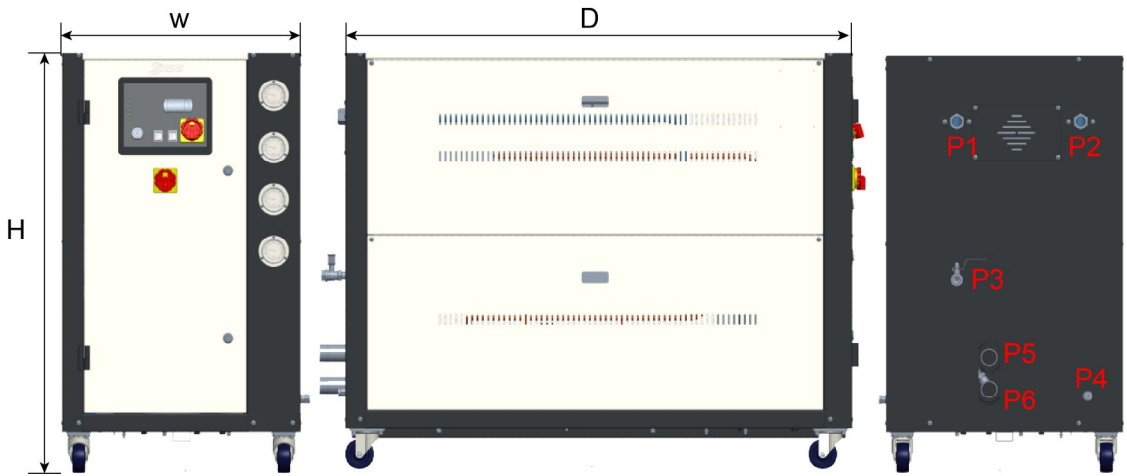

Picture 1-2: Outline Dimensional Drawing

Table 1-1: Specifications

Model	H (mm)	W (mm)	D (mm)	P1 Chilled water Inlet (inch)	P2 Chilled water outlet (inch)	P3 Water Tank Outfall (inch)	P4 Water Tank Overfall (inch)	P5 Cooling Water Outlet (inch)	P6 Cooling Water Inlet (inch)	Weight (kg)
SIC-5W-EB	1065	542	965	1	1	1/2	1/2	1.5	1.5	240
SIC-10W-EB	1140	695	1515	1	1	1/2	1/2	1.5	1.5	310
SIC-15W-EB	1205	905	1855	1.5	1.5	1/2	1/2	2.5	2.5	450

1.3.2 Specification List

Table 1-2: Specification List

Model		SIC-5W-EB	SIC-10W-EB	SIC-15W-EB	
Refrigerant capacity	kW	10	20	30	
	kcal/hr	8,609	17,217	25800	
Compressor	Type	Scroll			
	Output power	kW	3.3	6.6	13.3
		HP	5	8	15
Refrigerant	Filling volume(kg)	3.1	6.2	10	
	Control mode	Capillary		Expansion valve	
	Type	R410A			
Evaporator	Type	Tube style			
Condenser	Type	Tube-in-shell style			
	Inlet/outlet pipe(inch)	1.5	1.5	2.5	
	Cooling water flow(L/min)	65	90	136	
Water tank capacity(L)		65	90	161	
Water pump(50Hz)	Power(kW)	0.37	0.75	1.5	
	Pump flow(L/min)	60		133	
	Working pressure(Bar)	2.0		3.0	
Total power(kW)		4.2	7.8	14.8	
Pipe coupling(inch)	Chilled water outlet	1		1.5	
	Chilled water inlet	1		1.5	
	Water tank drainage Port	1/2		1/2	
	Water tank overflow Port	1/2		1/2	
Protective	Compressor	Built-in protective switch/overload relay			
	Pump	Overload relay			
	Refrigerant loop	High/low pressure controller			
Power		3Φ, 400VAC, 50Hz			
Measures exchange		1 kW = 860 Kcal/hr 1 RT = 3,024 Kcal/hr 10,000 Btu/hr = 2,520 Kcal/hr			

Note:

- 1) The refrigeration capacity is measured based on the inlet temperature (20 °C) of chilled water and inlet temperature (30 °C) of cooling water.
- 2) Special orders of machine voltage can be acceptable according to customers's request.

1.4 Safety Regulations

The user must conform to the following safety rules when operating the machine.

1.4.1 Security Labels



Attention!

Installation of the device is allowed only to the professional electrician.

Before maintaining and repairing the device, be sure to turn off the main switch and control switch.



Warning! High Voltage!

This label is posted on enclosure of the electrical control cabinet!



Warning! Be careful!

Pay more attentions at the places where this sign is attached!



Attention!

Drain the water inside when power off at the cold day to avoid freezing!



Attention!

No need for regular inspection because all the electrical parts in the control unit are fixed tightly!

1.4.2 Signs and Labels

	<p>Pump pressure gauge: display actual pressure of cold water system.</p>
	<p>High pressure gauge: display pressure in the high-pressure side of refrigerant system.</p>
	<p>Low pressure gauge: display pressure in the low-pressure side of refrigerant system.</p>
	<p>Cooling Water Outlet</p>
	<p>Cooling Water Inlet</p>
	<p>Chilled Water Return(From Mould)</p>
	<p>Chilled Water Outlet (To Mould)</p>
	<p>Drain</p>
	<p>Overflow</p>

1.5 Exemption Clause

The following statements clarify the responsibilities and regulations born by any buyer or user who purchases products and accessories from Shini (including employees and agents).

Shini is exempted from liability for any costs, fees, claims and losses caused by reasons below:

- 1) Any careless or man-made installations, operation and maintenances upon machines without referring to the Manual prior to machine using.
- 2) Any incidents beyond human reasonable controls, which include man-made vicious or deliberate damages or abnormal power, and machine faults caused by irresistible natural disasters including fire, flood, storm and earthquake.
- 3) Any operational actions that are not authorized by Shini upon machine, including adding or replacing accessories, dismantling, delivering or repairing.
- 4) Employing consumables or oil media that are not appointed by Shini.

2. Structural Features and Working Principle

2.1 Main Functions

SIC-W-EB Budget Water-cooled Water Chiller is constituted by 4 parts: compressor, condenser, capillaries and tube evaporator. It adopts the single-stage vapour compression refrigeration system and obtains the refrigerating effect by refrigerant gas-liquid transformation and heat absorption and release principle.

2.1.1 Working Principle

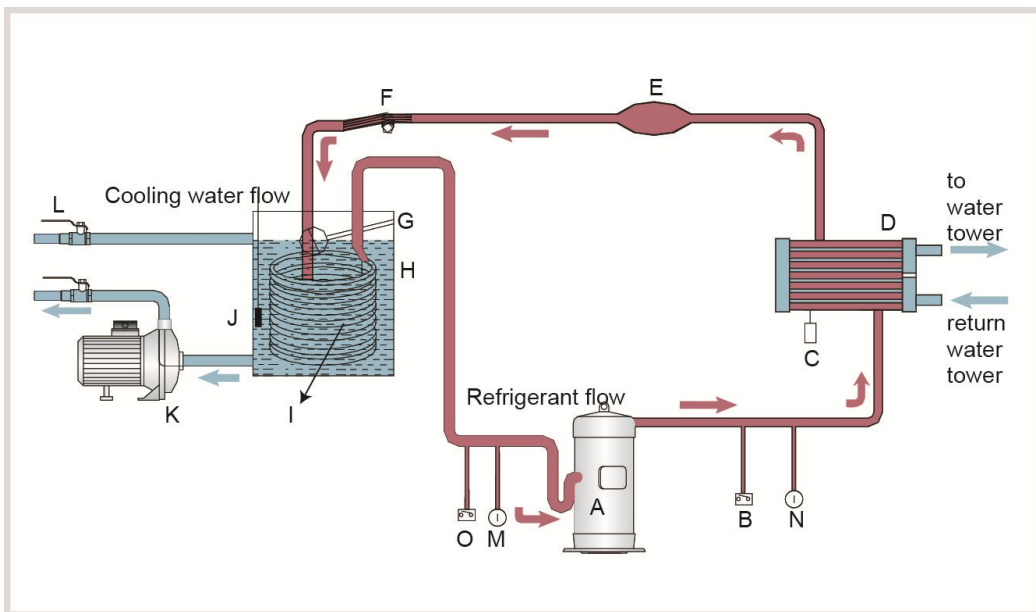

Parts name:

- | | | |
|------------------------|------------------------|----------------------------|
| A. Compressor | B. High pressure | C. Fusible plug |
| D. Condenser | E. Drying filter | F. Capillary |
| G. Floating-ball valve | H. Water tank | I. Tube evaporator |
| J. Thermocouple | K. Pump | L. Ball valve |
| M. Low pressure gauge | N. High pressure gauge | O. Low pressure controller |

Picture 2-1: Working Principle Diagram

When SIC-W-EB water-cooled water chiller starting up, compressor (A) starts working. Refrigerant is compressed into high temperature high pressure gas, and then be cooled when passing through condenser (D) and changed into

liquid. Heat is taken away by the cooling water. The liquid high pressure refrigerant passes through the capillary (F), and partially refrigerant is changed into gas under reduced pressure. At this time, the refrigerant is mixed with gas and liquid, which cools down the chilled water into required temperature after passing through the tube evaporator (I). By heat adsorption, the liquid refrigerant changes to gas and returns the compressor for this circulation.

2.1.2 Main Parts and Functions

2.1.2.1 Compressor

- 1) Compressing and conveying the refrigeration steam and forming low pressure in evaporator and high pressure in condenser, the compressor is the core of the whole system.
- 2) SIC-W-EB adopts scroll compressor.



Picture 2-2: Compressor

2.1.2.2 Condensor

- 1) Condenser is a heat output device which is used to discharge the heat absorbed by the evaporator and converted by the compressor to the cooling medium.
- 2) SIC-W-EB adopts horizontal tube-in-shell condenser.



Picture 2-3: Condenser

2.1.2.3 Drying Filter

- 1) The functions of the dry filter are: clean the impurity in the refrigerant, absorb the free moisture in the refrigerant, and prevent the narrow section (especially the valve port of the heat expansion valve) of the pipe from forming ice jam.
- 2) The size of the filter is usually chosen according to the caliber of the cooling agent pipe.
- 3) The dry filter is installed in front of the heat expansion valve to maintain the strictness of the valve.

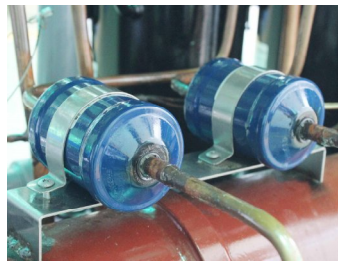

Picture 2-4: Drying Filter

2.1.2.4 Throttling Capillary or Thermal Expansion Valve

- 1) The throttling capillary or the thermal expansion valve throttles the refrigerant and reduces the pressure of it, as well as regulate the refrigerant flow which enters the evaporator.
- 2) Install it in front of the evaporator.

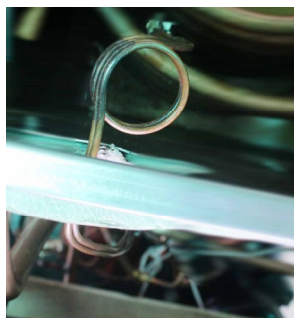

Picture 2-5: Throttling Capillary

2.1.2.5 Evaporator

- 1) The evaporator is a device that outputs the refrigerant, which absorbs the heat of the cooled object in the evaporator, so as to achieve the refrigerating purpose.
- 2) Our company uses the tube evaporator.



Picture 2-6: Evaporator

2.1.2.6 High and Low Pressure Controller

- 1) The high and low pressure controller is used to control the working pressure at the compressor air inlet and outlet.
- 2) The high-pressure controller is set to 30bar, and the low-pressure controller is set to 4bar.
- 3) It will give the alarm when the compressor outlet air pressure is higher than 30bar, or the compressor suction port is lower than 4bar.



Picture 2-7: High and Low Pressure Controller

3. Installation and Debugging



Attention!

Read this chapter before installation. Install the machine according to following steps!

3.1 Machine Positioning

- 1) Machine should be placed on the flat ground horizontally.
- 2) As to ensure enough installation and maintenance space of machine, it's suggested to keep at least 1m space round it during positioning.
- 3) The machine is standard equipped with castor, and two of them have braking function for convenient transportation. When machine moves to suitable position, it should brake off the castor as to prevent machine offset.

3.2 Pipeline Connection

- 1) According to the installation configuration diagram to install the pipe system, and use thermal insulation materials to protect the refrigerated water pipe.
- 2) Choose the suited cooling water tower according to the refrigerating capacity of the water chiller. The specific information could consult the cooling tower supplier.
- 3) The diameter of the circulate pump line should not be smaller than the condenser pipe diameter. (Piping system should be mounted according to the assembly diagram). Heavy caliber pipe should be used to connect the cooling water in long distance delivery.
- 4) At the lowest part of cooling water circulation, drainage valve should be installed.
- 5) Water filter should used in the cooling water and chilled water circulation pipe if water quality and surroundings of cooling tower is bad.
- 6) After the installation is completed, check if there are leakages in the circulation system. Cooling water circulation pipe should be covered with a layer of insulated material to avoid temperature increasing and water drops forming on the surface of circulation pipe.

- 7) This series of models mainly use cooling tower's circulation to cool down the water. During the installation, users should provide enough cooling water to the water chiller. Otherwise, machine would over high pressure and reduce cooling capacity. The dimension of cooling water inlet/outlet and the flow please refer to 1.3 Technical Specifications. Cooling water pressure should be 2.5~4bar, cooling water temperature is suggested at 25~35°C.
- 8) The water used in this system should be processed with treatment. As the high alkaline water would accelerate pipe corrosion, and lower the service life of the heat exchanger. Keep the PH value at 7.0~8.5.

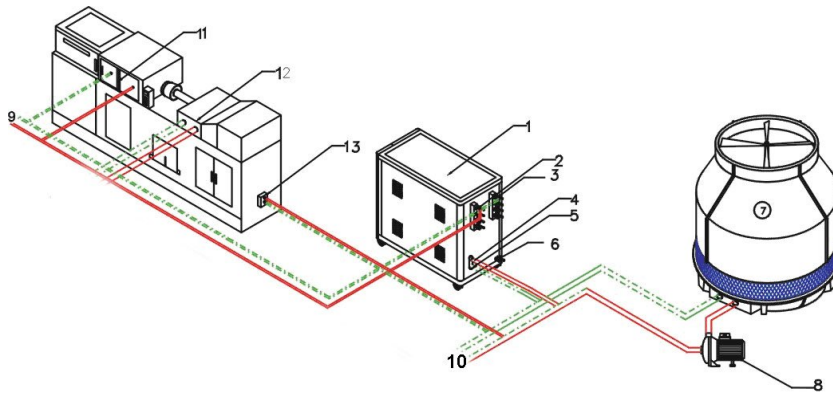

Parts Name:

- | | | |
|-------------------------------|-------------------------|------------------------------|
| 1. Water chiller | 2. Chilled water outlet | 3. Chilled water inlet |
| 4. Cooling water outlet | 5. Cooling water inlet | 6. Water outfall |
| 7. Cooling water tower | 8. Cooling water pump | 9. Chilled water circulation |
| 10. Cooling water circulation | 11. Mould cooling | 12. Cooling tank |
| 13. Oil cooling | | |

Picture 3-1: Installation Location

3.3 Power Connection

- 1) Make sure that the voltage and frequency corresponds with the requirements on manufacturer's name plate.
- 2) Connection of the machine electrical wires and negative wire according to local rules and regulations.
- 3) Use independent electrical wires and switch. Diameter of electrical wire should not be smaller than that of the electric wire which is used for the electrical control box.

- 4) Wiring connections should be firmly fixed.
- 5) This series of water chillers adopts the three-phase five-wire power supply, which is connected to the live wire, (N) to the neutral wire, and (G) to the ground wire.
- 6) Power supply:
Voltage deviation: Rated voltage on the nameplate: $\pm 5\%$
Frequency deviation: $\pm 2\%$
- 7) ***Please refer to electrical drawing of each model to get the detailed power supply specifications***



Electrical wire connection of water chiller should be done by qualified electrician!

Electrical wiring circuit should not be modified unless authorized by our company. We shall not be reliable for machine damages caused by unauthorized modification.

3.4 Water Tank Filling

The filling port of this series model has connected to the water-tank circulation loop of the condenser. As long as the circulation loop works normally, it can ensure the normal filling of the water tank.



Attention!

Don't start up the water chiller before the tank is full filled with water!

4. Application and Operation

4.1 Control Panel



Picture 4-1: Control Panel

Table 4-1: Specification of Control Panel

No.	Name	Function Description	Remarks & Notices
1	Power indicator	After powering on, switch on the main power switch, the indicator will on.	Note: Don't try to disassemble any unit or touch any terminal after powering on, otherwise it may cause electric shock.
2	Power reverse phase alarm light	When the power phase sequence is incorrect or shortage, this light will on, and the buzzer will give an alarm. The system stops working.	After checking the power and exchanging the positions of any two power inlet cables to troubleshoot this fault. After troubleshooting, the lights and buzzers will reset.

3	Pump overload alarm light	When the pump current is too large, this light will be on and make the buzzer to sound an alarm. The system stops working.	Check if the motor is stuck or if the bearings are damaged. If the motor works normally, then check whether the set current of the thermal overload relay inside the control box is set too low again. After troubleshooting above faults, wait for about one minute and reset the thermal overload relay by pressing the blue reset "RESET" button to reset the alarm.
4	Compressor overload alarm light	When the compressor's working current exceeds the set value of the overheat switch, the light will on and it makes the buzzer to sound an alarm. The system stops working.	Check whether the value of current overheat switch is set reasonably. The current set value of overheat switch must be greater than the rated current of the compressor.
5	Too high pressure alarm light	When the compressor outlet's pressure exceeds the high-pressure controller, the light will light up and it makes the buzzer to sound an alarm. The system stops working.	Check whether the value of the high-pressure controller is set reasonably. The set value of the high-pressure controller is 30 bar.
6	Too low pressure alarm light	When the compressor inlet pressure is less than the set value of the low-pressure controller, the light will light up and it makes the buzzer to sound an alarm. The system stops working.	Check whether the value of the low-pressure controller is set reasonably. The set value of the low-pressure controller is 4bar.
7	Buzzer	When the system malfunctions, the buzzer will alarm.	
8	Compressor switch	For compressor start and stop.	Note: Turn on the pump, and then turn on the compressor.
9	Pump switch	For pump start and stop.	Note: The direction of pump operation must be correct.
10	Temperature controller	Temperature setting and control.	Please refer to Chapter 4-4 for detailed settings.

4.2 Machine startup

- 1) Turn on the main switch.

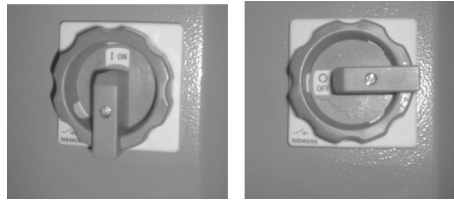

ON

OFF

Picture 4-2: ON/OFF

- 2) Turn on the pump.
- 3) Set chilling water temperature (Neglect this step if temperature is already set). Setting details please refer to 4.4 Chapter Temperature Controller. For this series of water chiller, lowest process temperature should be set as 7°C
- 4) Turn on the compressor.



Attention!

Pump rotating direction should be correct.



Attention!

Before starting the system, make sure that cooling water pump is turned on. Check the water tank of the chiller. Do not start the machine when there is no water left in water tank. We shall not be liable for any damages caused by this reason.



Attention!

In order to reduce the possibilities of machine damage and prolong the life, start the machine with correct methods.



Attention!

Anti-freezing switch and high/low pressure controller have been set in the factory, which forbids random adjustment without the company's permission. Otherwise, we are not liable for the responsibility of any machine damage.



Attention!

The compressor can't be started frequently because of its characteristics (Frequent start will shorten its service life.). Therefore, the compressor will work about 3 minutes later after turning on the water pump. The parameter of temperature controller shall not be adjusted freely since it is already set.

4.3 Machine Shutdown

- 1) Turn off the compressor.
- 2) Switch off the pump, and keep continuous running of water pump till the mould temperature rises non-condensate temperature on the condition of short molding cycle as well as low cooling water temperature. Then, switch off the pump switch.
- 3) Turn off the main switch.



Attention!

Avoid electrical shock when main switch is turned on.



Attention!

In order to reduce the possibilities of machine damage and prolong the service life, shut off the machine with correct methods.

4.4 Temperature Controller



Picture 4-3: Temperature Controller

4.4.1 Temperature Setting Method

- 1) Press the set button for 3 secs., and the screen will show a number that indicates current temperature set value.
- 2) Use the power or cold defrost key to modify the set temperature value, which has been limited to 7~25 °C at the factory. Finally, press the set key to confirm the modification (Return to the parameter menu).



Notice!

When the temperature unit changes, all parameters should be reset.

In standby mode, after pressing the L2 key, it can modify the 2DF parameters of the machine. We strongly recommended you not to modify this value, otherwise it may cause machine abnormalities.

4.4.2 Factory Parameters Setting Table

Table 4-2: Factory Parameters Setting Table

No.	Parameter Code	Parameter Meaning	Factory Setting Value	Remarks
1	1SP	OUT1 set value	7	Unit: °C

Note: This parameter is only applicable to temperature controller AC1-5TSR2W-A. Please don't use this parameter to set other model or version.



Notice!

Don't attempt to enter any other parameter, otherwise if you modify any other parameter values by accident, it may result in machine abnormalities.

Table 4-3: Alarm List

Alarm Code	Buzzer and Alarm Delay	LED	Description	Parameters Involved
E0	Enable	ON	Sensor 1 error = control	
E1	Disable	ON	Sensor 2 error = defrost	[d0=0/ [d0=0/1]
E2	Disable	ON	Sensor 3 error = condenser	[A4=10]
IA	Enable	ON	External alarm	[A4=1][+A7]

dOr	Enable	ON	Door opening alarm	[A4=7/8][+A7]
LO	Enable	ON	Low temp. alarm	[AL][Ad]
HI	Enable	ON	High temp. alarm	[AH][Ad]
EE	Disable	ON	Equipment parameter error	-
EF	Disable	ON	Running parameter error	-
Ed	Disable	ON	Stop defrosting based on timeout	[dP][dt][d4][A8]
dF	Disable	OFF	Defrost running	[d6=0]
cht	Disable	ON	Condenser dirt warning	[A4=10]
CHt	Enable	ON	Condenser dirt alarming	[A4=10]
EtC	Disable	ON	Clock alarm	If the clock is enabled

5. Trouble-shooting

Faults	The action of the protection units	The possible fault analysis	Solutions
No power supply display or phase reversal	The protection units have no action	<ul style="list-style-type: none"> A. The power supply is not switched on B. The fuse wire of the control loop is burned out C. The linear ordering of the power supply is in the reverse order D. The fault of the main switch or circuit 	<ul style="list-style-type: none"> A. Power on after checking B. Check the protection loop C. Change the wires in order of two random power supply wires D. Check or replace
Pump overload	The loader trips	<ul style="list-style-type: none"> A. Over current B. The fault of the pump C. The fault of the pump over loading controller 	<ul style="list-style-type: none"> A. Reset the over loader B. Replace after checked and repaired C. Replace after checked and repaired
Compressor overload	The loader trips	<ul style="list-style-type: none"> A. Over current B. The fault of the compressor C. The fault of the compressor over loading controller 	<ul style="list-style-type: none"> A. Reset the over loader B. Replace after checked and repaired C. Replace after checked and repaired
The high pressure is too high	The high pressure switch trips	<ul style="list-style-type: none"> A. The refrigerant is too much B. Insufficient water flow of the condenser C. The sediment incrustation of the condenser is too much D. The drying filter is blocked up E. The open scale of the expansion valve is too narrow F. The fault of the expansion valve G. The fault of the cooling pump H. The fault of the high pressure controller 	<ul style="list-style-type: none"> A. Discharge some of the refrigerant B. Increase the water flow of the condenser C. Clean the condenser D. Replace the drying filter E. Adjust the open scale properly F. Replace after checked and repaired G.. Replace after checked and repaired H. Replace after checked and repaired
The high pressure is too low	The protection units have no action	<ul style="list-style-type: none"> A. The refrigerant is not enough. B. The vanes of the compressor are damaged C. The water flow of cooling water is too big. 	<ul style="list-style-type: none"> A. Add refrigerant. B. Replace after checked and repaired. C. Adjust the water flow.
The low pressure is too low	The low pressure switch trips	<ul style="list-style-type: none"> A. The refrigerant is not enough B. The dry filter is blocked up C. The open scale of the expansion valve is too small D. The fault of the expansion valve E. The fault of the low pressure switch 	<ul style="list-style-type: none"> A. Check the system pipe lines, weld pipelines, and supply refrigerant. B. Clean the dry filter C. Adjust the open scale properly D. Replace after checked and

		<p>F. Bad heat transfer of the evaporator.</p> <p>G. Low system load.</p>	<p>repaired</p> <p>E. Replace after checked and repaired.</p> <p>F. Clean the evaporator.</p> <p>G. Add the load.</p>
The low pressure is too high	The protection units have no action	<p>A. The cooling load is too big</p> <p>B. The power of the compressor decreases</p> <p>C. The open scale of the expansion valve is too big</p> <p>D. The packed weight of the refrigerant is excessive</p>	<p>A. Adjust the cooling load</p> <p>B. Replace after checked and repaired</p> <p>C. Adjust the open scale of the expansion valve</p> <p>D. Discharge some of the refrigerant</p>
Compressor overheat	The protection units have no action	<p>A. The heat degree of the refrigerant in the air return pipe is too high</p> <p>B. The high pressure is too high</p> <p>C. The low pressure is too low</p>	<p>A. Adjust the open scale of the expansion valve properly</p> <p>B. Refer to 4.</p> <p>C. Refer to 6.</p>
The return-air pipe and the compress frost over	The protection units have no action	<p>A. The open scale of the expansion valve is too big.</p> <p>B. The refrigerant is too much</p> <p>C. The heat load is too small</p>	<p>A. Adjust the open scale of the expansion valve properly</p> <p>B. Discharge some refrigerant.</p> <p>C. Increase the heat load.</p>
The compressor can not start up or trips after starting up	The protection units have no action	<p>A. The power supply wire is broken or the voltage is off normal</p> <p>B. The temperature control instrument is not set up properly</p> <p>C. The over loading protector is not reset</p>	<p>A. Check and connect the wires according to Specifications</p> <p>B. Reset the temperature control instrument</p> <p>C. Reset the over loading protector</p>
	The freeze protection switch trips	<p>A. The amount of the ice water is too little and bring about that the water temperature is too low</p> <p>B. The temperature control is set too low or has some faults</p> <p>C. The freeze protection switch is not properly set or has some faults</p>	<p>A. Check the pump and discharge the air in the water pipe</p> <p>B. Correct the set point or change</p> <p>C. Check and repair</p>
The cooling capacity can not get up to the standard	-	<p>A. Too much incrustation in the evaporator.</p> <p>B. Too much incrustation in the condenser.</p> <p>C. Insufficient cooling water.</p> <p>D. Components blocked up.</p> <p>E. The configuration of the cooling pump is not prope</p> <p>F. Compressor aging.</p> <p>G. Expansion valve is damaged.</p>	<p>A. Clean the evaporator.</p> <p>B. Clean the condenser.</p> <p>C. Increase the amount of the cooling water.</p> <p>D. Clean or replace the components.</p> <p>E. Choose the pump up to the standard (flow and delivery lift).</p> <p>F. Repalce the compressor.</p> <p>G. Replace the expansion valve.</p>

6. Maintenance and Repair

Check before start or during operation. The corresponding working temperature is 30-62°C of normal range (environment temperature is 5-43°C).

Period: Daily

Check before start or during operation. The corresponding temperature for evaporation is -5°C as standard (vary according to operating temperature);

Period: Daily

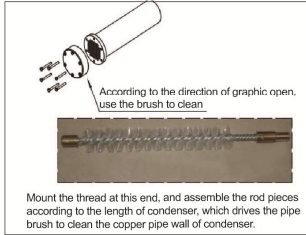

Clean the condenser.

Period: one year or half a year

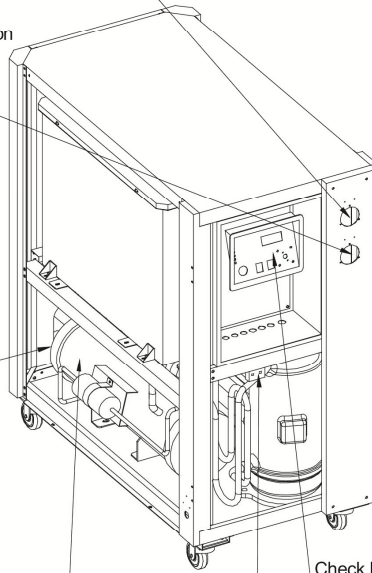

Check before start or during operation.
Period: Daily

Check if the value of high and low pressure switch is normal.
Period: Monthly

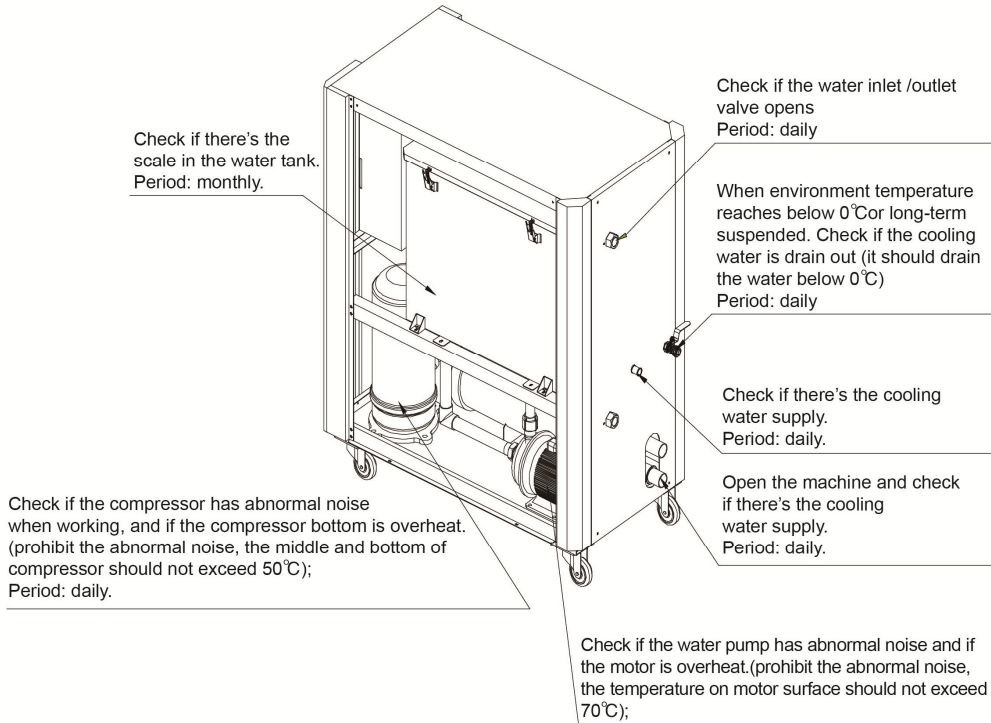

Attention!

All repair work should be done by qualified personnel only to avoid damage to the machine or personnel injury.

In order to operate the machine rightly and safely, please caution the matter follows:

- 1) Do not turn off the main power switch to stop the machine, except emergency situation.
- 2) When failures set in and the machine stop work with buzzer sound, first turn off the main power switch of the machine (alarm indicator will die), then go to check the reason of the failures, do not force the machine on before remove the failures.
- 3) Please check periodically to prolong the life of the machine and prevent the safety accident to appear.
- 4) The operation and service of the machine should be done by qualified technician only.



Please take notice that the disassembly and the inspection of the machines are hazardous when the machines are running!

6.1 Fill in the Refrigerant

- 1) Screw off the end cap of the liquid filling thimble valve, and connect the air suction pipe of the vacuum pump to the liquid filling thimble valve to take the vacuum pumping, and this process may take one to three hours.

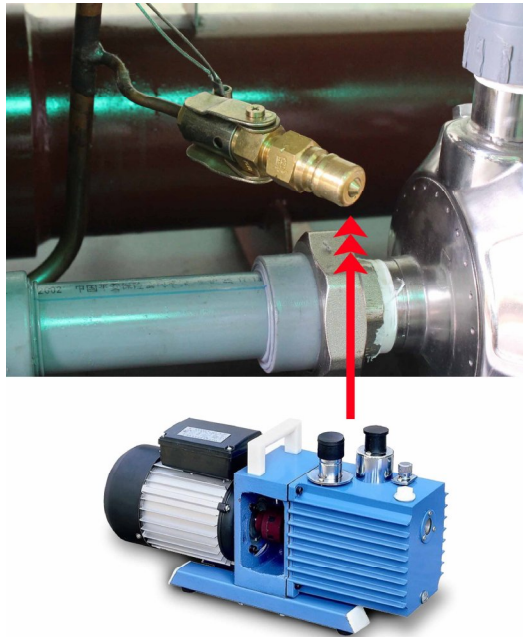

Picture 6-1: Fill in the Refrigerant

- 2) After the vacuum pumping, connect the air pipe of the refrigerant tank to the liquid filling thimble valve, and fill the refrigerant into the air return pipe. Watch the change of the weight displayed by the electronic scale, and stop filling the refrigerant immediately when receiving the schedule weight. Make sure that the filling refrigerant must be liquid and be filled when the machine stops. In the condition of the starting up, the shown pressure of the high pressure gage should be about 22 to 24 bar; and shown pressure of the low pressure gage should be about 7 to 8 bar. (Note: the ambient temperature should be 30°C, and the temperature of the chilled water should be 7°C.)

Table 6-1: SIC-W-EB Filling Quantity

Model	Quantity of Refrigerant (kg)
SIC-5W-EB	2.5
SIC-10W-EB	3.0



Attention!

- 1) Do not replace the refrigerant without permission.
- 2) Do not replace the components in the refrigerating system without permission.
- 3) Water is the standard working medium of the machine; consult the manufacturers for other mediums.

6.2 Components Maintenance

6.2.1 Condenser

SIC-W-R2 series water chiller adopts tube-in-shell condenser which may have incrustations piled up in the inner side of its heat pipe or sundries caused by bad water treatment. All these will influence the heat emission effect, so it is necessary to clean the condenser at fixed periods to ensure its good working performance.

If water treatment had been on to the cooling water, it is suggested that firstly use hydrogen peroxide for sterilization and then use high pressure air rifle to clean it and check whether there is still incrustation. If the cooling water had not be put under the water treatment, citric acid or sulfamic acid together with corrosion inhibitor is suggested to clean the condenser, after that use high pressure air rifle to clean it, and it is necessary to use passivator after the acid-washing.

Tube-in-shell Condenser Cleaning:

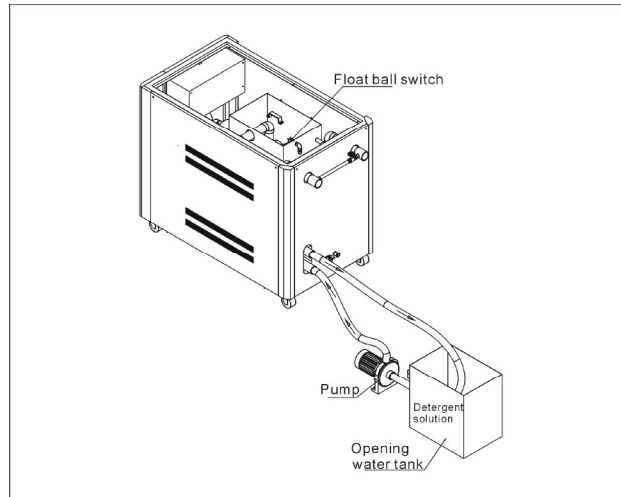

- 1) Ensure the float ball in water tank of the machine is closed, to prevent the detergent solution from getting into the water tank of the machine.
- 2) Connect pipeline with hoses according to above picture.
- 3) Detergent and water (according to purchased detergent mixing requirement for specific proportion) proportional to solution and pour into the opening water tank, then start-up pump cleaning.



Attention!

When the machine stops or be stored under 0°C , the pipeline should be disconnected and force the water in the condenser to come out by lifting the front part of the machine.

6.2.2 Evaporator

SIC-W-EB series water chiller adopts tube-in-shell condenser which may have incrustations piled up in the inner side of its heat pipe or sundries caused by bad water treatment. All these will influence the heat emission effect, so it is necessary to clean the condenser at fixed periods to ensure its good working performance.

Clean the evaporator use the method of cleaning the condenser, and the incrustation will discharged from the water outfall.

Tube-in-shell Evaporator Cleaning:

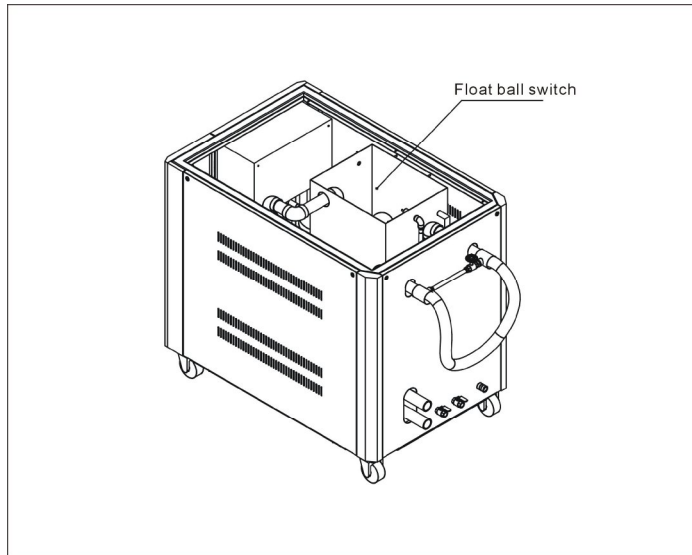

- 1) Connect chilling water inlet/outlet of machine with hoses according to above picture.
- 2) Bactericide and water (according to purchased bactericide mixing requirement for specific proportion) proportional to solution and pour into the water tank of machine, then start-up pump cleaning of the machine.
- 3) After discharging the bactericide solution when cleaning finished, it should repeat more turns of water washing to water tank for ensuring there's no bactericide solution left in the system.



Attention! Drain the water inside the evaporator away when the machine stop running under 0°C.

Melt the ice in the evaporator before starting it again.

6.3 Maintenance Schedule

6.3.1 About the Machine

Model _____ SN _____ Production date _____

Voltage _____ Φ _____ V Frequency _____ Hz

Total power _____ kW

6.3.2 Check after Installation

- Check the pipes are all correctly connected.
- Check if there are leakages in the piping system.
- Check if there are breaks in welding joint.

Electrical Installation

- Voltage: _____ V _____ Hz
- Fuse specification: 1 Phase _____ A 3 Phase _____ A
- Check phase sequence of power supply.

6.3.3 Daily Checking

- Check switch functions.
- Check all the electrical wires.
- Check whether pressure gauges are accurate.
- Check whether compressor temperature is normal.
- Check whether cooling water circulation is normal.

6.3.4 Weekly Checking

- Check electrical connections.
- Check protection & alarm function.
- Check whether set point of hi-low pressure switch is normal.

6.3.5 Montly Checking

- Check refrigerant circulation pipe.
- Check whether there are bubbles in liquid indicator.
- Check whether there is abnormal sound in pump.
- Check whether there is scale formation in tank.

6.3.6 Trimonthly Checking

- Check whether condenser is under blockage.

6.3.7 Half-yearly Checking

- Check and clean the condenser and evaporator.
- Check and clean the filter and expansion valve.
- Check system performance.
- Clean condenser.

6.3.8 Yearly Checking

- Check whether the contactor is normal.

6.3.9 3 year Checking

- PC board renewal.
- No fuse breaker renewal.