

1.1.1 Structural Drawing

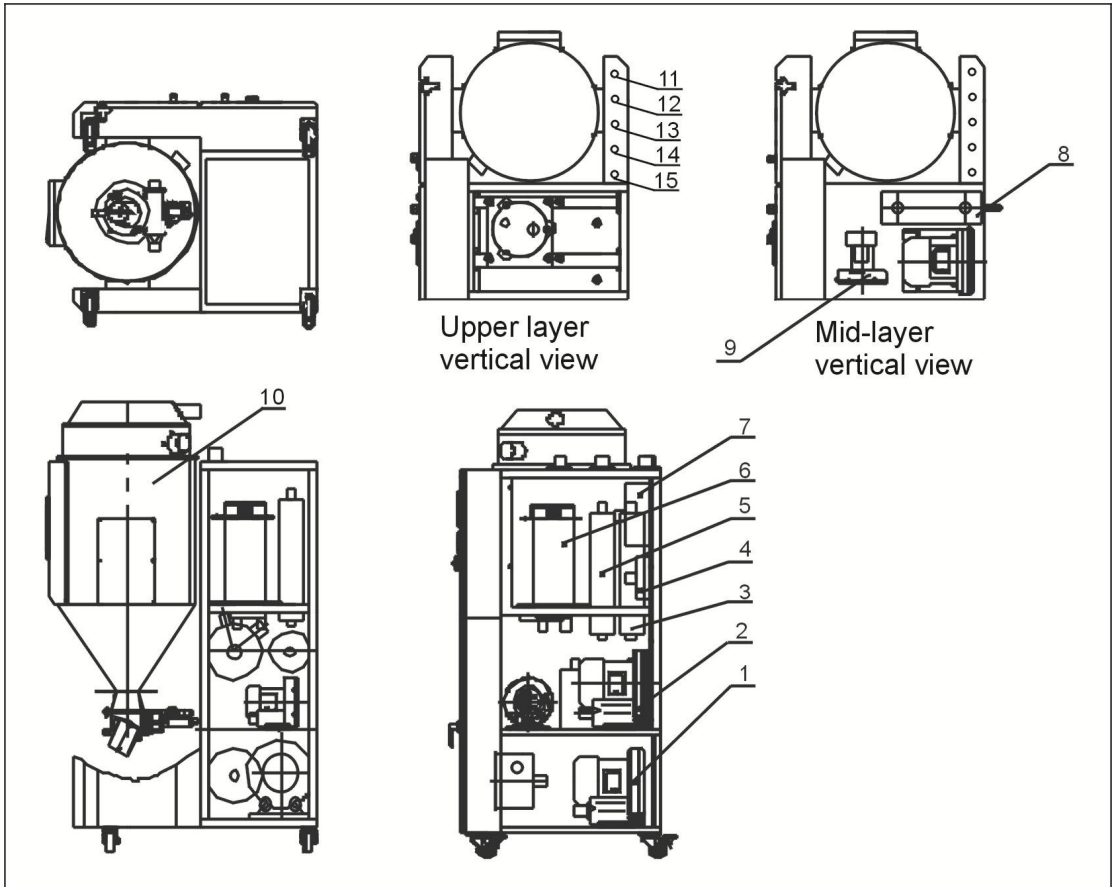

Names of Parts:

- | | | | |
|------------------------|--|--|----------------------|
| 1. Conveying blower | 2. Process blower | 3. Process heater | 4. Return-air filter |
| 5. Regenerating heater | 6. Honeycomb-rotor | 7. Regenerating filter | 8. After cooler |
| 9. Regenerating blower | 10. Drying hopper | 11. Material line | 12. Vacuum line 1 |
| 13. Vacuum line 2 | 14. Material line (option for three-stage conveying) | 15. Vacuum line (option for three-stage conveying) | |

1.1.2 Assembly Drawing (Fully-integral design) (SCD-20U/40H~450U/200H)

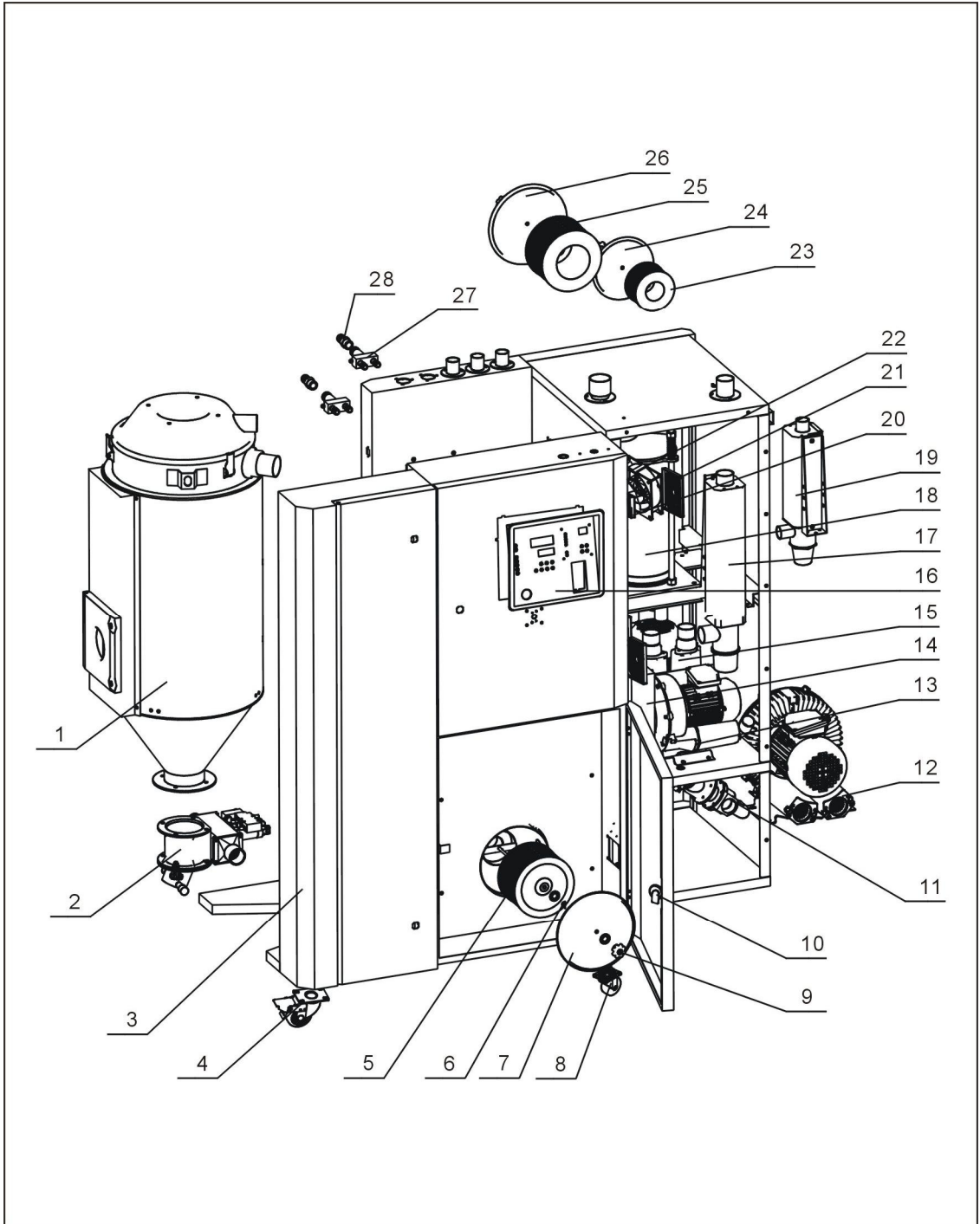

Remarks: Please refer to material list 1.1.3 for specific explanation of the Arabic numbers in parts drawing.

1.1.3 Parts List (Fully-integral design) (SCD-20U/40H~450U/200H)

Table 1: Parts list (Fully-integral design) (SCD-20U/40H~80U/40H)

No.	Description	Part No.		
		20U/40H	40U/40H	80U/40H
1	Heat insulated hopper	BY10002000150	BY10004000150	BY10008000150
2	Cut-off valve type suction box	BY10203800050	BY10203800050	BY10203800050
3	rack metal plate	-	-	-
4	Black brake castor 3"	YW03000300000	YW03000300000	YW03000300000
5	Conveying filter	YR50708000100	YR50708000100	YR50708000100
6	Butterfly nut 5/16"	-	-	-
7	Filter barrel lid	-	-	-
8	Black movable castor 3"	YW03000300200	YW03000300200	YW03000300200
9	Star knob 5/16"	YW09675100000	YW09675100000	YW09675100000
10	Door lock (MS816-1 with black key)	-	-	-
11	Three-way valve	-	-	-
12	Conveying blower*	BM30042000050	BM30042000050	BM30042000050
13	Regen. blower *	BM30020500050	BM30020500050	BM30020500050
14	Cooler	BW88030500020	BW88030500020	BW88030500020
15	Drying blower	BM40338000950	BM40338000950	BM40338000950
16	Plastic panel	YR40000400400	YR40000400400	YR40000400400
17	Drying heater	Refer to 1.1.11	Refer to 1.1.11	Refer to 1.1.11
18	Honeycomb assembly	Refer to 1.1.7	Refer to 1.1.7	Refer to 1.1.7
19	Regen. heater	Refer to 1.1.11	Refer to 1.1.11	Refer to 1.1.11
20	Big hinge CL203-1(right)	-	-	-
21	Exhaust fan*	YM60121200400	YM60121200400	YM60121200400
22	Anti-dust screen	YR40120300000	YR40120300000	YR40120300000
23	Regen.filter	YR50128300100	YR50128300100	YR50128300100
24	Filter barrel lid	-	-	-
25	Circulation filter	YR50128300100	YR50128300100	YR50128300100
26	Filter barrel lid	-	-	-
27	Water flow regulator	-	-	-
28	Copper insert core	-	-	-

* means possible broken parts.

** means easy broken part. and spare backup is suggested.

Please confirm the version of manual before placing the purchase order to guarantee that the item number of the spare part is in accordance with the real object.

Table -2: Parts list (Fully-integral design) (SCD-120U/80H~230U/120H)

No.	Description	Part No.		
		120U/80H	160U/80H~ 160U/120H	230U/120H
1	Heat insulated hopper	BY10012000250	BY10016000150	BY10023000050
2	Cut-off valve type suction box	BY10203800050	BY10203800050	BY10203800050
3	rack metal plate	-	-	-
4	Black brake castor 3"	YW03000300000	YW03000300000	YW03000300000
5	Conveying filter	YR50708000100	YR50708000100	YR50708000100
6	Butterfly nut 5/16"	-	-	-
7	Filter barrel lid	-	-	-
8	Black movable castor 3"	YW03000300200	YW03000300200	YW03000300200
9	Star knob 5/16"	YW09675100000	YW09675100000	YW09675100000
10	Door lock (MS816-1 with black key)	-	-	-
11	Three-way valve	-	-	-
12	Conveying blower*	BM30042000050	BM30042000050	BM30042000050
13	Regen. blower *	BM30020500050	BM30020500050	BM30020500050
14	Cooler	BW88081200000	BW88081200000	BW88081200000
15	Drying blower	BM30031000150	BM30031000150	BM30031000150
16	Plastic panel	YR40000400400	YR40000400400	YR40000400400
17	Drying heater	Refer to 1.1.11	Refer to 1.1.11	Refer to 1.1.11
18	Honeycomb assembly	Refer to 1.1.7	Refer to 1.1.7	Refer to 1.1.7
19	Regen. heater	Refer to 1.1.11	Refer to 1.1.11	Refer to 1.1.11
20	Big hinge CL203-1(right)	-	-	-
21	Exhaust fan*	YM60121200400	YM60121200400	YM60121200400
22	Anti-dust screen	YR40120300000	YR40120300000	YR40120300000
23	Regen.filter	YR50128300100	YR50128300100	YR50128300100
24	Filter barrel lid	-	-	-
25	Circulation filter	YR50708000100	YR50708000100	YR50708000100
26	Filter barrel lid	-	-	-
27	Water flow regulator	-	-	-
28	Copper insert core	-	-	-

* means possible broken parts.

** means easy broken part. and spare backup is suggested.

Please confirm the version of manual before placing the purchase order to guarantee that the item number of the spare part is in accordance with the real object.

Table-3: Parts list (Fully-integral design) (SCD-300U/200H~450U/200H)

No.	Description	Part No.	
		300U/200H	450U/200H
1	Heat insulated hopper	BY10030000550	BY10030000550
2	Cut-off valve type suction box	BY10203800050	BY10203800050
3	rack metal plate	-	-
4	Black brake castor 3"	YW03000300000	YW03000300000
5	Conveying filter	YR50708000100	YR50708000100
6	Butterfly nut 5/16"	-	-
7	Filter barrel lid	-	-
8	Black movable castor 3"	YW03000300200	YW03000300200
9	Star knob 5/16"	YW09675100000	YW09675100000
10	Door lock (MS816-1 with black key)	-	-
11	Three-way valve	-	-
12	Conveying blower*	BM30042000050	BM30042000050
13	Regen. blower *	BM30020500050	BM30020500050
14	Cooler	BW88152000020	BW88152000020
15	Drying blower	BM30042000050	BM30042000050
16	Plastic panel	YR40000400400	YR40000400400
17	Drying heater	Refer to 1.1.11	Refer to 1.1.11
18	Honeycomb assembly	Refer to 1.1.9	Refer to 1.1.9
19	Regen. heater	Refer to 1.1.11	Refer to 1.1.11
20	Big hinge CL203-1(right)	-	-
21	Exhaust fan*	YM60121200400	YM60121200400
22	Anti-dust screen	YR40120300000	YR40120300000
23	Regen.filter	YR50708000100	YR50708000100
24	Filter barrel lid	-	-
25	Circulation filter	YR50203000000	YR50203000000
26	Filter barrel lid	-	-
27	Water flow regulator	-	-
28	Copper insert core	-	-

* means possible broken parts.

** means easy broken part. and spare backup is suggested.

Please confirm the version of manual before placing the purchase order to guarantee that the item number of the spare part is in accordance with the real object.

1.1.4 Assembly Drawing (Semi-integral design) (SCD-600U/400H~1200U/700H)

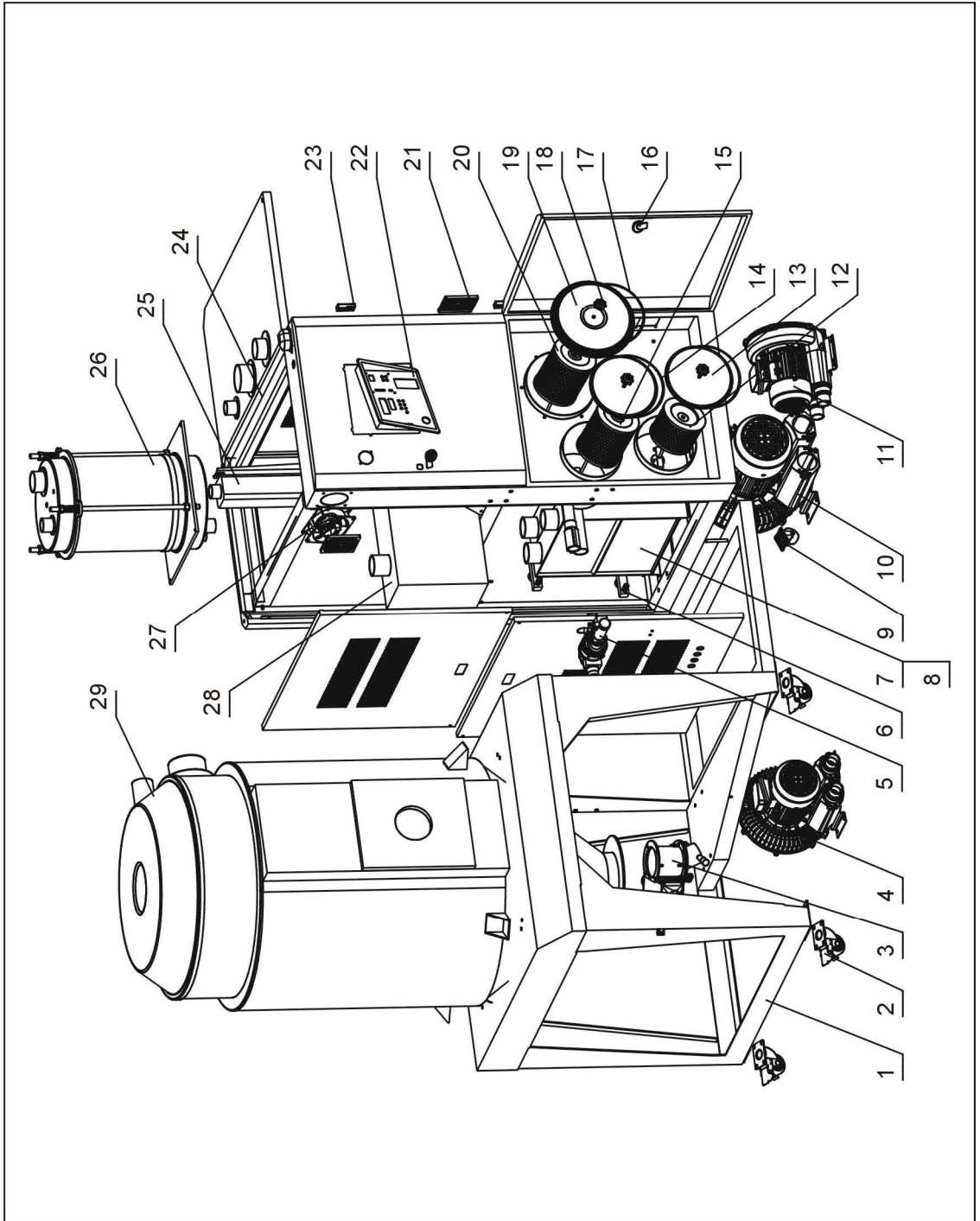

Remarks: Please refer to material list 1.1.5 for specific explanation of the Arabic numbers in parts drawing.

1.1.5 Parts List (Semi-integral Design) (SCD-600U/400H~1200U/700H)

Table -4: Parts list (Semi-integral design) (SCD-600U/400H~1200U/700H)

No.	Description	Part No.	
		SCD-600U/400H ~750U/400H	SCD-900U/700H ~1200U/700H
1	Bottom frame	-	-
2	Black brake castor 4"	YW03000400000	YW03000400000
3	Cut-off valve type suction box	BY10163800050	BY10165000250
4	Conveying blower *	BM30042000050	BM30053500050
5	Three-way valve	BY20001500050	-
6	Water flow regulator	-	-
7	Cooler (no side hole)	BW88030300020	-
8	Cooler	BW88030030020	-
9	Black movable castor 4"	YW03000400200	YW03000400200
10	Drying blower	BM30055000050	BM30075000050
11	Regen. blower *	BM30031000150	BM30042000050
12	Regen.filter	YR50708000100	YR50181100000
13	Filter barrel lid	-	-
14	Filter fastener (SAL-700/800G)	YR10708000000	YR10708000000
15	Conveying filter **	YR50241400100	YR50241400100
16	Door lock (MS816-1 with key)	YW00816100000	YW00816100000
17	Fastener for filtering barrel □260	YR10026000000	YR10026000000
18	Star nut 5/16"	YW09675100000	YW09675100000
19	Filter barrel lid **	-	-
20	Circulation filter	YR50203000000	YR50203000000
21	Anti-dust screen	YR40120300000	YR40120300000
22	Plastic panel	YR40000400400	YR40000400400
23	Big hinge CL203-1(right)	YW06203100200	YW06203100200
24	Rack metal plate	-	-
25	Regen. heater	-	-
26	Honeycomb assembly	Refer to 1.1.9	Refer to 1.1.9
27	Exhaust fan **	YM60121200400	YM60121200400
28	Heating case		
29	Heat insulated hopper	BY10060000250	-

* means possible broken parts.

** means easy broken part. and spare backup is suggested.

Please confirm the version of manual before placing the purchase order to guarantee that the item number of the spare part is in accordance with the real object.

1.1.6 Honeycomb Assembly (SCD-20U/40H~230U/120H)

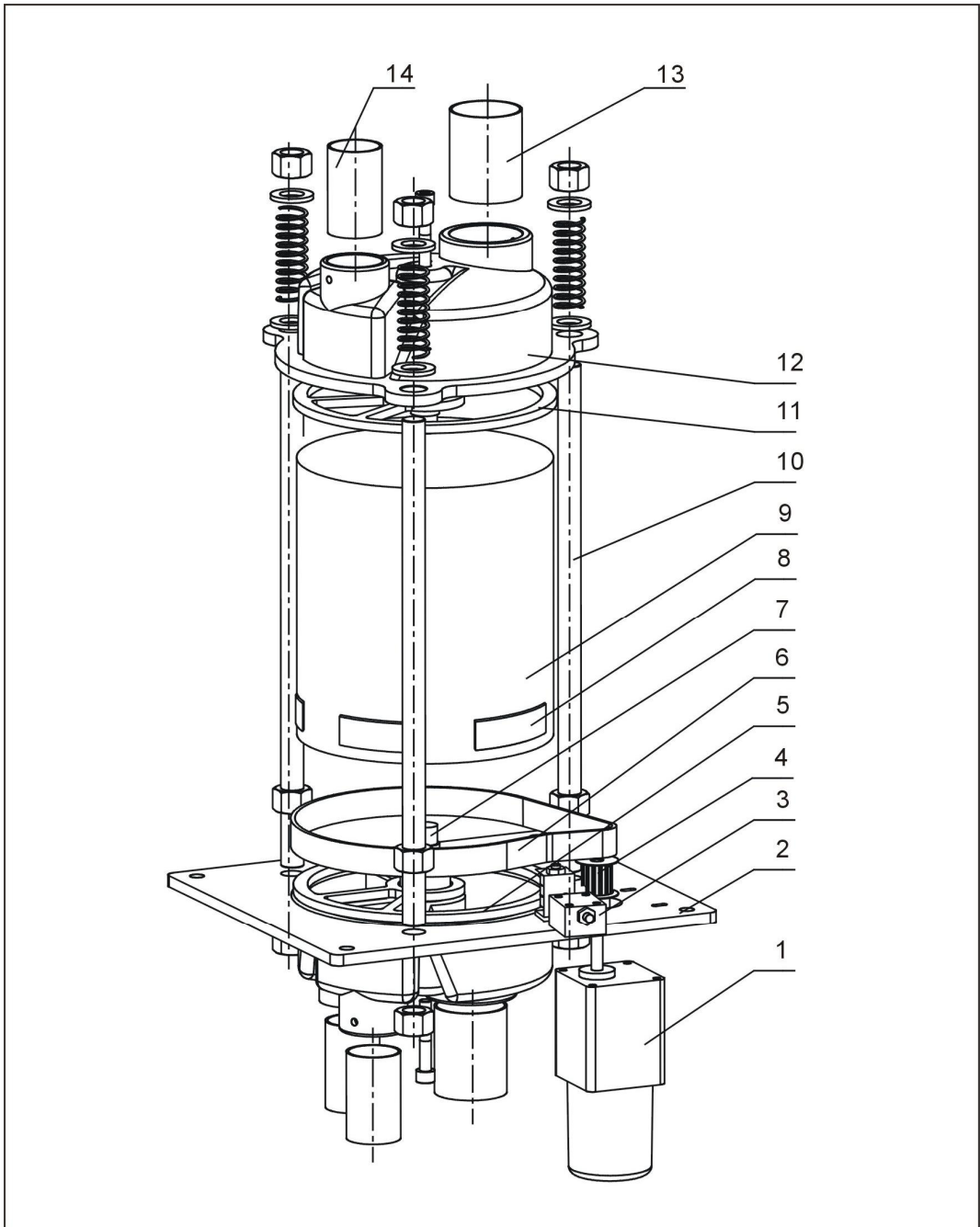

Remarks: Please refer to material list 1.1.7 for specific explanation of the Arabic numbers in parts drawing.

1.1.7 Parts List of Honeycomb Assembly (SCD-20U/40H~230U/120H)

Table-5: Parts list of honeycomb assembly (SCD-20U/40H~230U/120H)

No.	Description	Part No.		
		SCD-20U/40H ~80U/40H	SCD-120U/80H ~160U/80H	SCD-160U/120H~ 230U/120H
1	Gear motor	YM50031500000	YM50512600000	YM50512600000
2	Honeycomb lower cover	-	-	-
3	Belt regulator	-	-	-
4	Synchronous wheel	-	-	-
5	Silica-gel Teflon pad (low)	YR10081200000	YR10081200000	YR10081200000
6	Synchronous belt	YR00025400000	YR00025400000	YR00025400000
7	Honeycomb mounting shaft	-	-	-
8	Synchronous belt	-	-	-
9	Honeycomb	YW71018000500	YW71018000600	YW71018000700
10	Double-head screw	-	-	-
11	Silica-gel Teflon pad (upper)	YR10081200200	YR10081200200	YR10081200200
12	Honeycomb upper cover	-	-	-
13	Drying air flange	-	-	-
14	Regenerative air flange	-	-	-

Please confirm the version of manual before placing the purchase order to guarantee that the item number of the spare part is in accordance with the real object.

1.1.8 Honeycomb Assembly (SCD-300U/200H~1200U/700H)

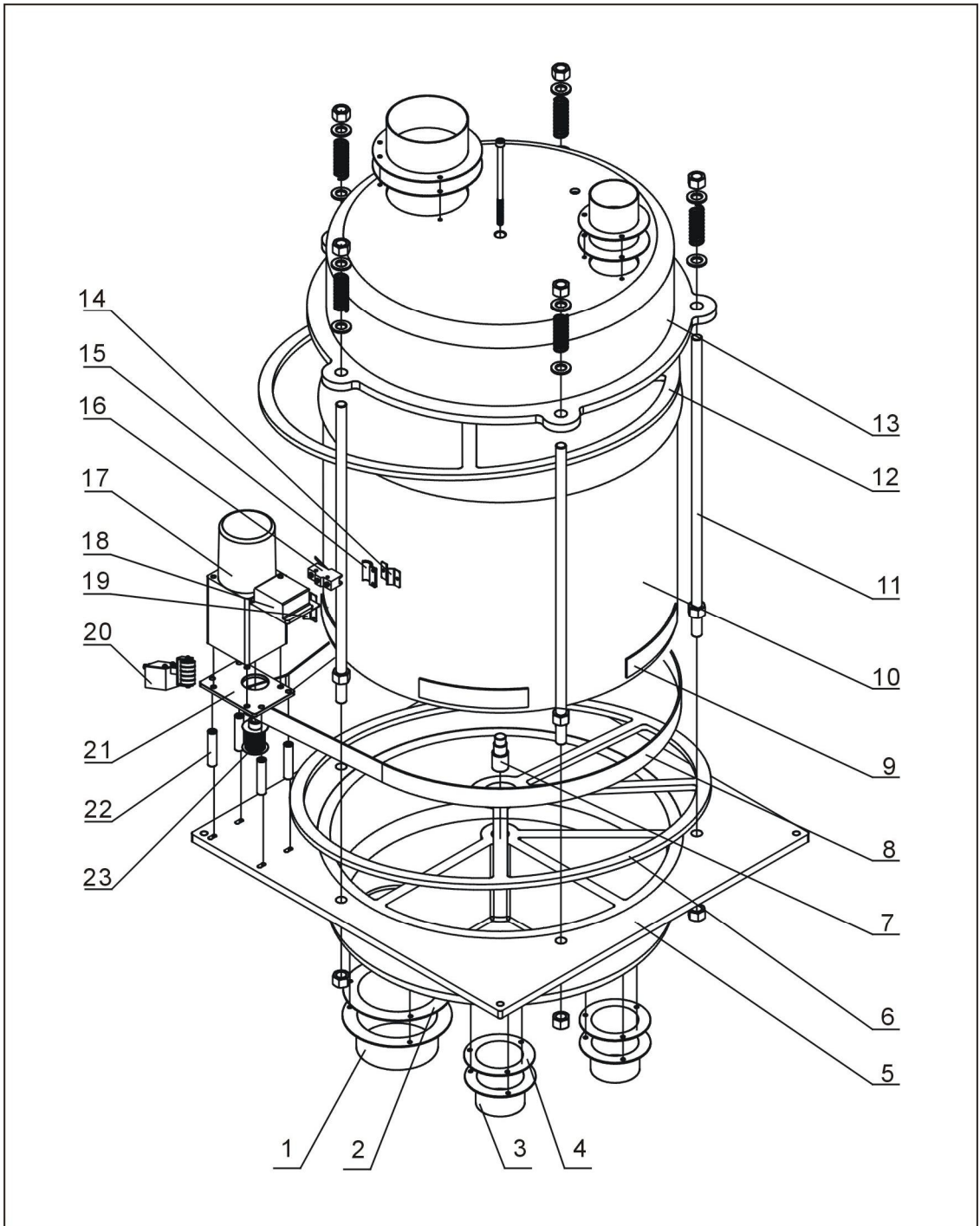

Remarks: Please refer to material list 1.1.9 for specific explanation of the Arabic numbers in parts drawing.

1.1.9 Parts List of Honeycomb Assembly (SCD-300U/200H~1200U/700H)

Table -6: Parts list of honeycomb assembly (SCD-300U/200H~1200U/700H)

No.	Description	Part No.		
		SCD-300U/200H ~450U/200H	SCD-600U/400H ~750U/400H	SCD-900U/700H ~1200U/700H
1	Drying air flange	-	-	-
2	Flange washer	YR90002500000	YR90000300100	YR90000400100
3	Regenerative air flange	-	-	-
4	Flange washer	YR90001500200	YR90000200000	YR90002500000
5	Honeycomb lower cover	BA40152000010	BA40304000010	BA40507000000
6	Silica-gel Teflon pad (low)	YR10152000000	YR10304000000	YR10507000000
7	Honeycomb mounting shaft	BH11101300010	BH11101300010	BH11101300010
8	Synchronous belt	YR00203400000	YR00304700000	YR00305800000
9	Synchronous belt	YR00003000000	YR00003000000	YR00003000000
10	Honeycomb	YW71250400000	YW71354000000	YW71440400000
11	Double-head screw	-	-	-
12	Silica-gel Teflon pad (upper)	YR10152000100	YR10304000100	YR10507000100
13	Honeycomb upper cover	BA40152000110	BA40304000110	BA40507000110
14	Honeycomb fixing piece	-	-	-
15	Micoswitch fixed plate	-	-	-
16	Micro switch	YE14152400000	YE14152400000	YE14152400000
17	Gear motor	YM50512600000	YM50512600000	YM50512600000
18	Micoswitch box	-	-	-
19	Micoswitch fixed plate 2	-	-	-
20	Belt regulator	-	-	-
21	Gear motor mounting plate	-	-	-
22	Fixing pipe	-	-	-
23	Synchronous wheel	-	-	-

Please confirm the version of manual before placing the purchase order to guarantee that the item number of the spare part is in accordance with the real object.

1.1.10 Heater Assembly

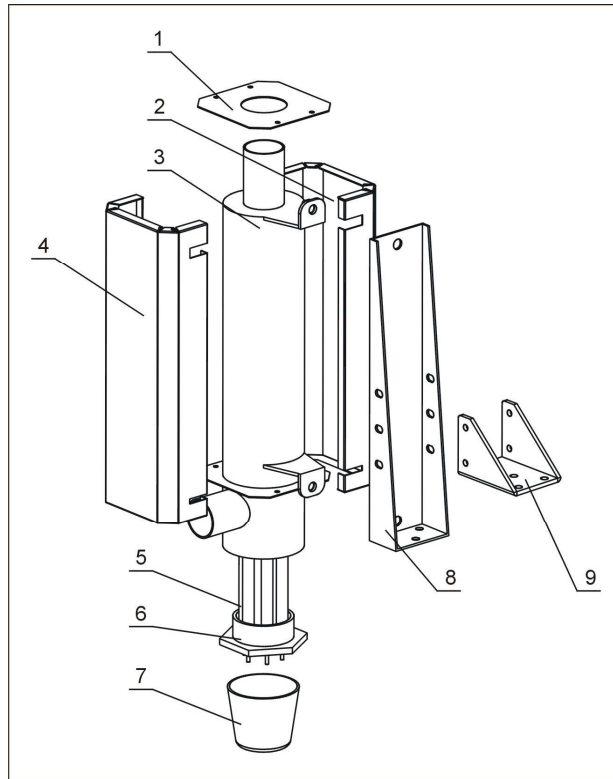

Remarks: Please refer to material list 1.1.11 for specific explanation of the Arabic numbers in parts drawing.

1.1.11 Parts List of Heater Assembly

Table -7: Parts list of heater assembly(SCD-20U/40H~450U/200H)

No.	Description	Part No.		
		SCD-20U/40H ~80U/40H	SCD-120U/80H ~230U/120H	SCD-300U/200H ~450U/200H
1	Heater cover plate	-	-	-
2	Heater cover plate 1	-	-	-
3	Heating tank	-	-	-
4	Heater cover plate 2	-	-	-
5	Drying pipe heater*	BH70150400050	BH70120600050	BH70150400050
	Regenerating pipe heater*(50Hz)	BH70183460000	BH70183460000	BH70150400050
	Regenerating pipe heater*(60Hz)		BH70150400050	BH70120600050
6	Heater copper head	BH12200500310	BH12200500310	BH12200500310
7	Bakelite cover	YR90200600000	YR90200600000	YR90200600000
8	Heater fixed frame	-	-	-
9	Heater fixed angle	-	-	-

Table -8: Parts list of heater assembly (SCD-20U/30H-OP~120U/80H-OP)

No.	Description	Part No.		
		SCD-20U/30H ~40U/30H-OP	SCD-80U/50H-OP	SCD-120U/80H-OP
1	Heater cover plate	-	-	-
2	Heater cover plate 1	-	-	-
3	Heating tank	-	-	-
4	Heater cover plate 2	-	-	-
5	Drying pipe heater*	BH70183460000	BH70150400050	BH70120600050
	Regenerating pipe heater*		BH70183460000	BH70183460000
6	Heater copper head	BH12200500310	BH12200500310	BH12200500310
7	Bakelite cover	YR90200600000	YR90200600000	YR90200600000
8	Heater fixed frame	-	-	-
9	Heater fixed angle	-	-	-

* means possible broken parts.

** means easy broken part. and spare backup is suggested.

Please confirm the version of manual before placing the purchase order to guarantee that the item number of the spare part is in accordance with the real object.

Table -9: Parts list of heater assembly(SCD-600U/400H ~1200U/700H)

No.	Description	Part No.	
		SCD-600U/400H ~750U/400H	SCD-900U/700H ~1200U/700H
1	Heater cover plate	-	-
2	Heater cover plate 1	-	-
3	Heating tank	-	-
4	Heater cover plate 2	-	-
5	Pipe heater*	BH70407200050	BH70501000050
6	Heater copper head	BH12200500310	BH12200500310
7	Bakelite cover	YR90200600000	YR90200600000
8	Heater fixed frame	-	-
9	Heater fixed angle	-	-

* means possible broken parts.

** means easy broken part. and spare backup is suggested.

Please confirm the version of manual before placing the purchase order to guarantee that the item number of the spare part is in accordance with the real object.

1.1.12 Heater Case Assembly (SCD-300U/200H~1200U/700H)

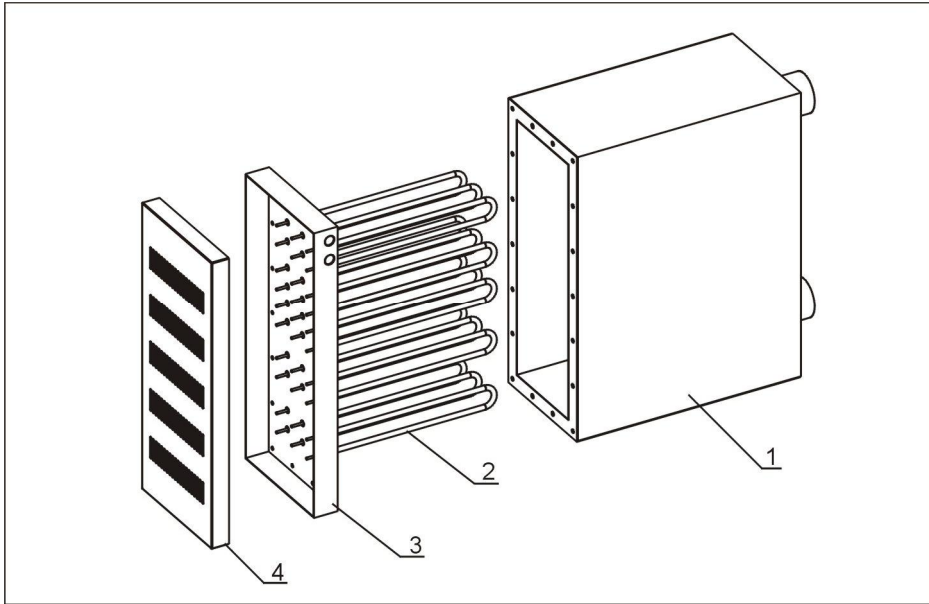

Remarks: Please refer to material list 1.1.13 for specific explanation of the Arabic numbers in parts drawing.

1.1.13 Parts List of Heater Case Assembly(SCD-300U/200H~1200U/700H)

Table -10: Parts list of heater case assembly (SCD-300U/200H~1200U/700H)

No.	Description	Part No.		
		SCD-300U/200H ~450U/200H	SCD-600U/400H ~750U/400H	SCD-900U/700H 1200U/700H
1	Heating case body	-	-	-
2	Pipe heater*	BH70451200050	BH70751800050	BH70122400050
3	Pipe heater mounting plate	-	-	-
4	Heating case cover plate	-	-	-

* means possible broken parts.

** means easy broken part. and spare backup is suggested.

Please confirm the version of manual before placing the purchase order to guarantee that the item number of the spare part is in accordance with the real object.

1.1.14 Material Stage Bin of Optical Grade MST-80U-OP

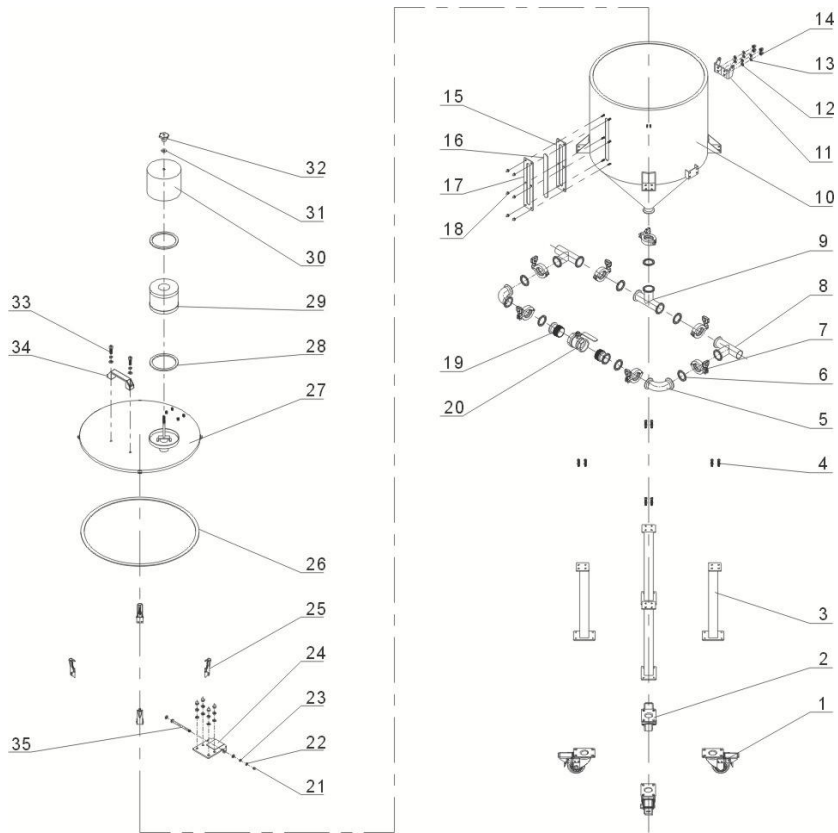

Name of components:

- | | | |
|-------------------------------------|-------------------------------------|-------------------------------------|
| 1. Brake-type universal floor stand | 2. Free-style universal floor stand | 3. Floor stand |
| 4. Inner hexagonal screw column | 5. 1.5" Elbow | 6. Seal ring 1.5" |
| 7. 1.5" Fast pipe connector | 8. Feed port | 9. 1.5" Three way |
| 10. Material storage tank | 11. Cover back button 2 | 12. Flat gasket |
| 13. Spring gasket | 14. Acorn nut 8 | 15. Fastener for sight glass window |
| 16. Acryl | 17. Fastener for sight glass window | |
| 18. Nut | 19. Connection pipe | 20. 1.5" Ball valve |
| 21. Acorn nut | 22. Spring gasket | 23. Flat gasket |
| 24. Cover back button 1 | 25. Snap hook | 26. Material storage tank fastener |
| 27. Material storage tank top | 28. Filter 1 fastener | 29. Filter 1 |
| 30. Filter cover 1 | 31. Flat gasket | 32. Star nut |
| 33. Inner hexagonal screw column | 34. Square aluminum handle | 35. Pin |

1.1.15 High-efficiency Filter HEPA

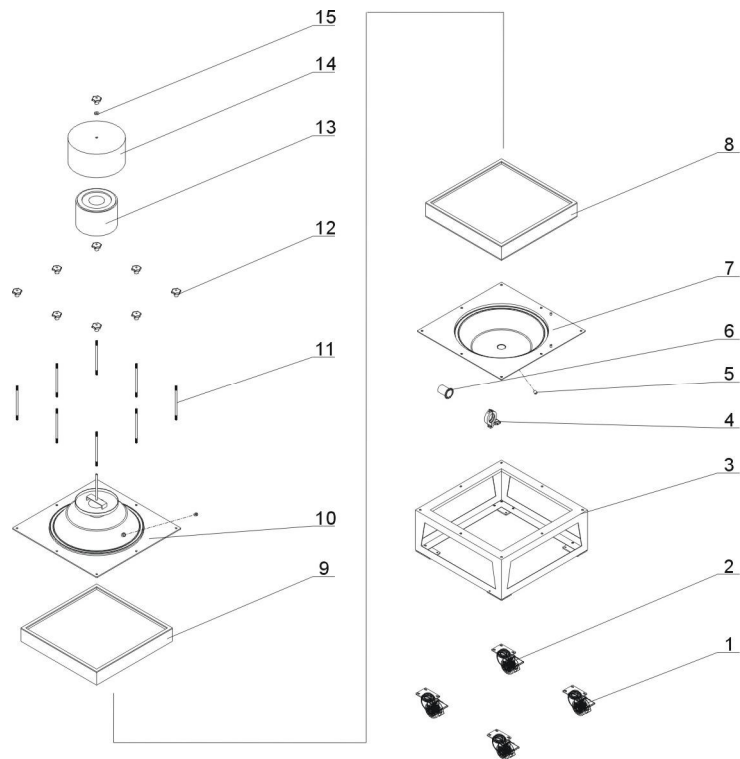

Name of components:

- | | |
|-------------------------------------|-------------------------------------|
| 1. Brake-type universal floor stand | 2. Free-style universal floor stand |
| 3. Floor stand | 4. Clamp tube |
| 5. Metric taper thread | 6. Connector |
| 7. Bottom cover of filter | 8. High-efficiency filter |
| 9. Middle-efficiency filter | 10. Top cover of filter |
| 11. Screw shaft | 12. Star screw |
| 13. Low-efficiency filter | 14. Filter cover |
| 15. Stainless steel washer | |

1.1.16 Important notices for using SHR-CP-3U

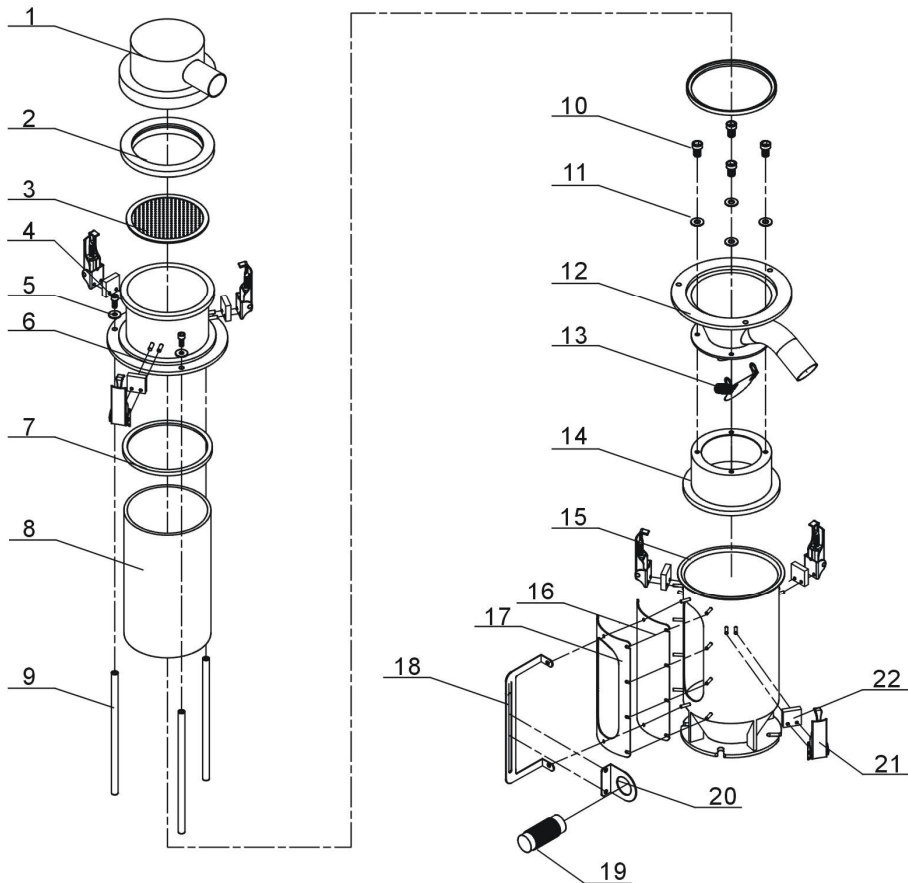

Name of components:

- | | | | |
|--------------------------------------|----------------------------|----------------------------|-------------------|
| 1. Top cover | 2. Screener fastener | 3. Screener | 4. Flat gasket M6 |
| 5. Inner hexagon column screw M6×15 | | 6. Glass pipe upper flange | |
| 7. Glass pipe packing | 8. Glass tube | 9. Flange connection shaft | |
| 10. Inner hexagon column screw M5×15 | | 11. Flat gasket | |
| 12. Glass tube lower flange | 13. Non-return flap | 14. Bottom cover board | |
| 15. Base | 16. Sight-glass | 17. Sight-glass iron sheet | |
| 18. Supporting frame | 19. Sensor fixing plate | 20. Sensor | |
| 21. Snap hook | 22. Snap hook fixing plate | | |