

Insulated type(Optional)

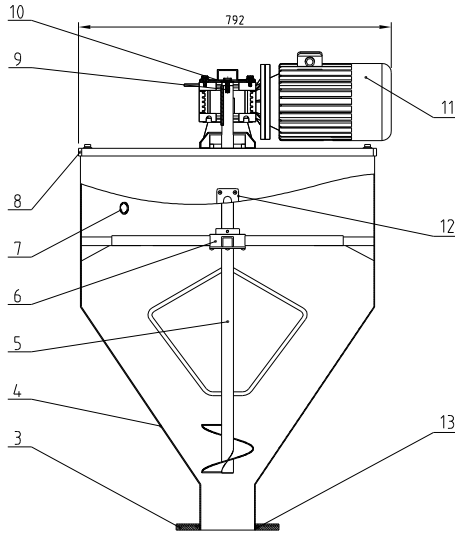

Standard

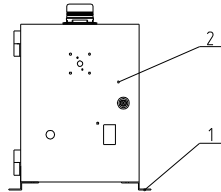
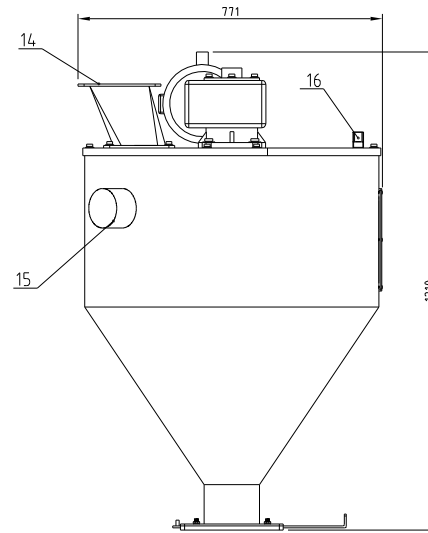

22		Motor top cover welding drawing	Assembly	1	
21		Flat key	45	1	
20		Visual window cover	SUS201	1	•
19		Barrel cover plate	Aluminum plate with patterns	1	•
18	YP60001000100	Insulation cotton	Aluminum silicate	1	•
17		Barrel (optional insulated)	Assembly	1	•
16	BW20012000040	Aluminum Square Handle120L	LY12	1	
15	YE15000200000	Rotary level sensor SR-80-T	Assembly	1	•
14		Adaptor flange 1	SUS201	1	
13		Shut-off plate	SUS201	1	
12	BH90000600050	Sight glass six holes assembly	Assembly	1	
11	YM500754.00100	Dongyuan gear motor	Assembly	1	
10	YW66123200100	Big gasket GB/T96 12(13X37X3)		1	
9	YW61122000000	Inner hexagon cylinder screw M12x20		1	
8		Barrel cover welding drawing	Assembly	1	
7	BH12901620010	Level sensor plug	H58	1	
6		Fixed frame of mixing shaft	Assembly	1	
5		Mixing assembly	Assembly	1	
4		Barrel welding drawing	Assembly	1	
3		Shut-off plate flange	SUS201	1	
2		Control box assembly drawing	Assembly	1	
1		Control box fixing plate	SPCC2.0	2	
No.	Part No.	Name	Material	Quantity	Remark

Remark: \* means the optional insulated mode

制图	版号	标题	SBH-160U	图号	比例	1:12	数量	1
设计	核准	SBH assembly drawing		信易电热机械股份有限公司 Shini Plastics Technologies, Inc.	材质	表面要求	物料号	
校对	日期	标记	更改前					更改后