

# **SAL-330/360**

**Self-contained Hopper Loader**

Date: Jun. 2019

Version: Ver.B





## Content

<b>1. General Description .....</b>	<b>7</b>
1.1 Coding Principle.....	7
1.2 Features.....	7
1.3 Options .....	7
1.4 Technical Specifications .....	9
1.4.1 External Dimensions .....	9
1.4.2 Mounting Base Specifications .....	9
1.4.3 Loading Capacity.....	10
1.4.4 Specification List .....	10
1.5 Safety Regulations.....	11
1.6 Exemption Clause.....	12
<b>2. Structure Characteristics and Working Principle.....</b>	<b>13</b>
2.1 Working Principle.....	13
<b>3. Assembly Drawing .....</b>	<b>15</b>
3.1 Assembly Drawing (SAL-330).....	15
3.2 Assembly Drawing (SAL-360).....	16
<b>4. Electrical Circuit Diagram.....</b>	<b>17</b>
4.1 Main Circuit Diagram (115V).....	17
4.2 Electrical Components Layout (115V).....	18
4.3 Electrical Components List (115V).....	19
4.4 Main Circuit Diagram (230V).....	20
4.5 Electrical Components Layout (230V).....	21
4.6 Electrical Components List (230V).....	22
4.7 Main Electrical Components Description.....	23
4.7.1 AC Contactor.....	23
<b>5. Installation and Debugging .....</b>	<b>24</b>
5.1 Installation of SAL-330 / 360 .....	24
5.1.1 Installation Methods of SAL-330 / 360.....	24
5.1.2 Installation Methods of SAL-330/360 Optional Proportional Valve SPV-U .....	25
5.2 Installation Space .....	26

<b>6. Application and Operation</b> .....	<b>27</b>
6.1 Control Panel .....	28
6.2 Function Setup .....	29
6.2.1 Setup .....	29
6.2.2 Actions .....	30
6.2.3 Parameter List .....	33
6.2.4 Other Settings .....	33
<b>7. Troubleshooting</b> .....	<b>34</b>
7.1 Troubleshooting for SAL-330/360 Series .....	34
<b>8. Maintenance and Repair</b> .....	<b>35</b>
8.1 Filter Screen.....	35
8.1.1 Service Life of Product Key Part.....	36
8.2 Hopper.....	36
8.3 Cloth Filter.....	36
8.4 Blower .....	37
8.5 Maintenance Schedule .....	38
8.5.1 About the Machine .....	38
8.5.2 Check after Installation .....	38
8.5.3 Daily Checking .....	38
8.5.4 Weekly Checking.....	38
8.5.5 Monthly Check.....	38

#### Table Index

Table 1-1: Specification list.....	10
Table 6-1: Control panel description.....	27

#### Picture Index

Picture 1-1: External dimensions .....	9
Picture 1-2: Mounting base specifications.....	9
Picture 1-3: Loading capacity.....	10
Picture 2-1: Working principle of SAL-330/360 .....	13
Picture 4-1: Contactor .....	23
Picture 5-1: Installation methods of SAL-330/360 .....	24
Picture 5-2: Installation method of optional SPV-U .....	25

Picture 5-3: Installation space.....	26
Picture 6-1: Control panel .....	27
Picture 8-1: Filter screen.....	35
Picture 8-2: Cloth filter .....	36



## 1. General Description



Please read through this operation manual before using and installation to avoid damage of the machine and personal injuries.

The SAL-330/360 series use a high-speed motor in this lightweight and compact unit. With superior suction power and easy installation. It is particularly suitable for conveying new materials.

### 1.1 Coding Principle



### 1.2 Features

- I Stainless steel hopper, motor overload protector.
- I SAL-330/360 integrated design features compact structure and light weight.
- I When mounted at the inlet of the injection molding machine, SAL requires to work with the storage collective hopper SCH-U or SICH-U.
- I All the machines are equipped with auto reverse cleaning kit and cloth mesh filter.

### 1.3 Options

- I Manual control switch is optional to deal with conditions that power supply is hard to manage when machine is installed at higher places. Add "RS" at the end of model code.
- I Quick mixing valve can be opted to work with proportional valve to enhance mixing effect. Add "QM" at the end of model code.
- I For polished hopper inside ones, add "P" at the end of the model code.

All service work should be carried out by a person with technical training or corresponding professional experience. The manual contains instructions for

both handling and servicing. Chapter 12, which contains service instructions intended for service engineers. Other chapters contain instructions for the daily operator.

Any modifications of the machine must be approved by SHINI in order to avoid personal injury and damage to machine. We shall not be liable for any damage caused by unauthorized change of the machine.

Our company provides excellent after-sales service. Should you have any problem during using the machine, please contact the company or the local vendor.

Headquarter and Taipei factory:

Tel: (886) 2 2680 9119

Shini Plastics Technologies (Dongguan), Inc:

Tel: (86) 769 8111 6600

Shini Plastics Technologies India Pvt.Ltd.:

Tel: (91) 250 3021 166



## 1.4 Technical Specifications

### 1.4.1 External Dimensions

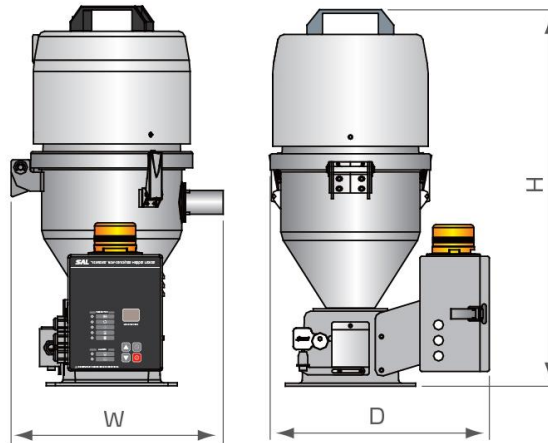

SAL-330/360

Picture 1-1: External dimensions

### 1.4.2 Mounting Base Specifications

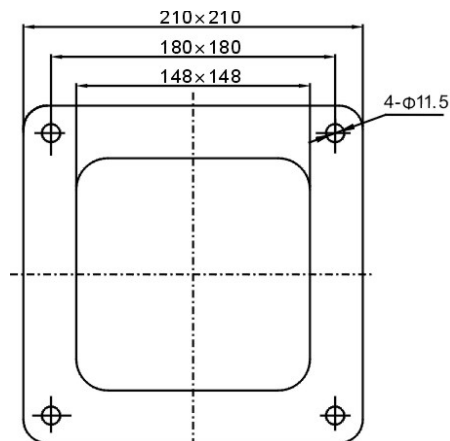

SAL-330/360

Picture 1-2: Mounting base specifications

### 1.4.3 Loading Capacity

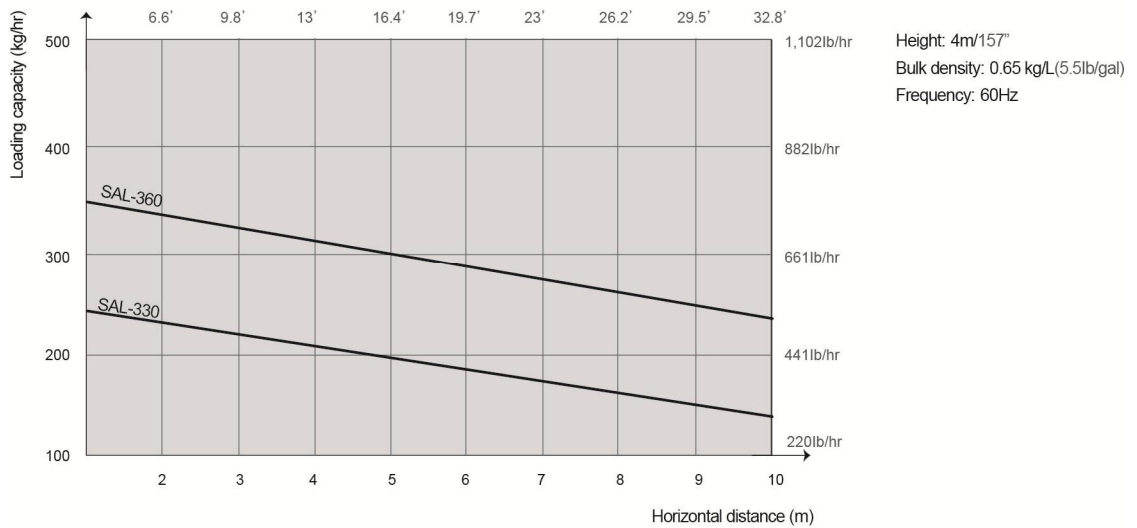

Picture 1-3: Loading capacity

### 1.4.4 Specification List

Table 1-1: Specification list

Model	SAL-330	SAL-360
Ver.	B	B
Motor Type	Carbon brush	Carbon brush
Motor Power(kW)(50 / 60Hz)	1.15	1.15
Conveying Pipe Dia.(Inch)	1.5	1.5
Conveying Capacity (kg / hr, 50Hz)	240	350
Hopper Capacity (L)	3	6
Input Voltage	1 Φ ,230V,50Hz	
Material Level Control	Microswitch	
Cloth Filter	Standard	
Auto-cleaning	Standard	
Dimensions		
H(mm)	610	670
W(mm)	345	385
D(mm)	355	380
Weight (kg)	13	14

Note: 1) For hopper inside polished ones, add "P" at model behind.

2) Test condition of conveying capacity: Plastic material of bulk density 0.65kg/L, dia. 3~5 mm, vertical conveying height: 4m, horizontal conveying distance: 1m.V.

## 1.5 Safety Regulations

Please abide by the safety guide when you operate the machine so as to prevent damage of the machine and personal injuries.



Attention!

All electrical components should be installed by qualified electricians.  
Turn off main switch and control switch during repair and maintenance.



Warning! High voltage!

This mark is attached on the cover of the control box.



Warning! Be careful!

Be more careful when this mark appears.

### Transportation and Storage of the Machine

#### Transportation

- 1) SAL series hopper loader are packed in paper cartons. Handle with care when to move the machine by hands.
- 3) Do not rotate the machine and avoid collision with other objects during transportation to prevent improper functioning.
- 4) The structure of the machine is well-balanced, although it should also be handled with care when lifting the machine for fear of falling down.
- 5) The machine and its attached parts can be kept at a temperature from  $-25^{\circ}\text{C}$  to  $+55^{\circ}\text{C}$  for long distance transportation and for a short distance, it can be transported with temperature under  $+70^{\circ}\text{C}$ .

#### Storage

- 1) SAL series hopper loader should be stored indoors with temperature kept from  $5^{\circ}\text{C}$  to  $40^{\circ}\text{C}$  and humidity below 80%.
- 2) Disconnect all power supply and turn off main switch and control switch.
- 3) Keep the whole machine, especially the electrical components away from water to avoid potential troubles caused by the water.
- 4) Plastic film should be used to protect the machine from dust and rains.

#### Working Environment

The machine should be operated:

- 1) Indoors in a dry environment with max. temperature +45°C and humidity nomore than 80%.

Do not use the machine:

- 1) If it is with a damaged cord.
- 2) On a wet floor or when it is exposed to rain to avoid electrical shock.
- 3) If it has been dropped or damaged until it is checked or fixed by a qualified serviceman.
- 4) This equipment works normally in the environment with altitude within 3000m.
- 5) At least a clearance of 1m surrounding the equipment is required during operation.  
Keep this equipment away from flammable sources at least two meters.
- 6) Avoid vibration, magnetic disturbance at the operation area.

#### Rejected Parts Disposal

When the equipment has run out its life time and can not be used any more, unplug the power supply and dispose of it properly according to local code.

Fire Hazard!



In case of fire, CO<sub>2</sub> dry powder fire extinguisher should be applied.

## 1.6 Exemption Clause

The following statements clarify the responsibilities and regulations born by any buyer or user who purchases products and accessories from Shini (including employees and agents).

Shini is exempted from liability for any costs, fees, claims and losses caused by reasons below:

1. Any careless or man-made installations, operation and maintenances upon machines without referring to the manual prior to machine using.
2. Any incidents beyond human reasonable controls, which include man-made vicious or deliberate damages or abnormal power, and machine faults caused by irresistible natural disasters including fire, flood, storm and earthquake.
3. Any operational actions that are not authorized by Shini upon machine, including adding or replacing accessories, dismantling, delivering or repairing.
4. Employing consumables or oil media that are not appointed by Shini.

## 2. Structure Characteristics and Working Principle

### 2.1 Working Principle

SAL-330/360 series are suitable for conveying plastic granules. The blower makes vacuum of material hopper by drawing the air out. Materials will then be sent into material hopper.

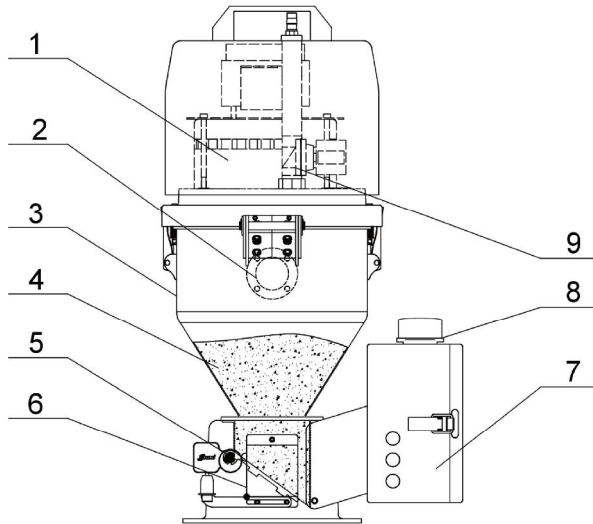

Picture 2-1: Working principle of SAL-330/360

- |                        |                        |                            |
|------------------------|------------------------|----------------------------|
| 1. Carbon brush blower | 2. Material inlet pipe | 3. Storage hopper          |
| 4. Material            | 5. Discharging plate   | 6. Microswitch             |
| 7. Control box         | 8. Alarm light         | 9. Reverse cleaning device |

After starting the machine, reverse cleaning device (9) begins to wash the dust covered in the hop- pocket and hopper. After that, carbon brush blower (1) starts to work and produces vacuum in the storage hopper (3). Meanwhile, close the discharging plate (5), and the material in the storage bucket will be conveyed through material inlet pipe (2) into the material storage hopper (3) under the function of minus pressure and the air flow. After finishing material suction, carbon brush blower(1) stops working and the materials(4) will fall down by self-gravity. When microswitch (6) detects that no materials remain in the storage hopper(3), and after the dust get through the reverse cleaning device(9), the carbon brush blower(1) starts to work again. When blower cannot suck

materials from the storage bucket, the alarm light (8) in the control box (7) will be blinking to indicate that the materials are not enough.

### 3. Assembly Drawing

#### 3.1 Assembly Drawing (SAL-330)

NO.	Past Name	Part NO.	NO.	Past Name	Part NO.
1	Grit hole *	BL20333600020	28	E-type washer ES	YW66000500000
2	Base fastener *	YR10000000600	29	Iron rod	BH10061400040
3	Counter weight hammer	YW20602100000	30	Motor fastening plate	BH90601200050
4	Ejector pin assembly	BH10000600050	31	Air vent window *	YR40002400100
5	Control box fixing plate	BL20333600020	32	Square base	BA10040000260
6	limit switch *	YE14511200000	33	Motor fastener(lower) *	YR10135500000
7	Microswitch box *	YR40330900000	34	Carbon brush motor (for 33V) *	YM30965600000
8	Control box	YW9090330060000	35	Motor fastener(upper) *	YP62141200000
9	Alarm Lamp *	BL90011500020	36	Motor fixing plate	BL21000300420
10	Lower hinge	BL32000600140	37	Motor cover *	YR40000300100
11	Hexagonal nut M5 anti-loose	YW64000500000	38	Aluminium square handle *	BW20012000040
12	Hinge pin	BH10006000310	39		
13	E-rings 6	YW66000600000			
14	Snap hook block *	YR40000600800	40		
15	Snap hook *	YW02003000400	41		
16	Locknut M4	YW64040700100	42		
17	Split washer of filter cloth *	YR40003000100	43		
18	Cloth-bag *	BP82003000044	44		
19	Reverse cleaning pipe nozzle	BH13033000810	45		
20	Reverse-cleaning pipe fastener *	BR10281500050	46		
21	Upper hinge	BL32000600240	47		
22	Hopper cover	BL20033000120	48		
23	Connection nut	BH12030400410	49		
24	Cloth-bag purging device (for 230V)	YW900033000500	50		
25	Material inlet pipe	YW900033005500	51		
26	Pipe inlet fastener *	BL32333600020	52		
27	Storage hopper	YR10061200000	53		
			54		

\* means possible broken parts. \*\* means easy broken part, and spare backup is suggested. Please confirm the version of manual before placing the purchase order to guarantee that the item number of the spare part is in accordance with the real object.

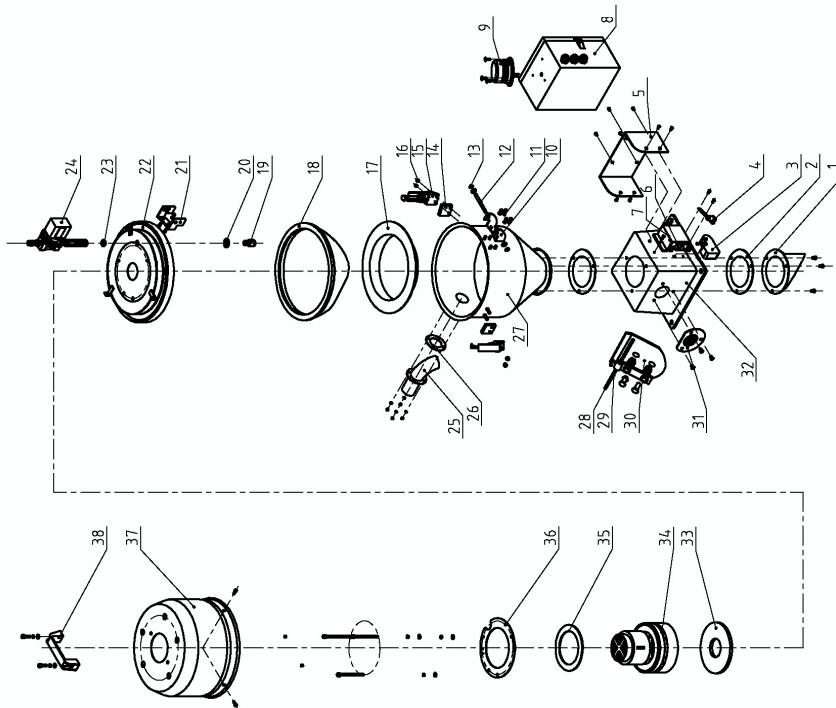

### 3.2 Assembly Drawing (SAL-360)

NO.	Part Name	Part No.	NO.	Part Name	Part No.
1	Grit hole *	BL20333600020	28	Motor fastener (lower) * (can be brush motor)	YR10135500000
2	Base fastener *	YR100000000600	29	Carbon brush motor (for 15V) *	YM30966100000
3	Counter weight hammer	YW206021000100	30	Motor fastener(upper) *	YP62141200000
4	Ejector pin assembly	BH10000600050	31	Motor fixing plate	BL21000300420
5	Control box fixing plate	BL20333600120	32	Motor cover *	YR40036000000
6	Limit switch *	YE1451200000	33	Aluminum square handle (Cloth-bag purging device for 15V)	BW20012000040
7	Microswitch box *	YR40330900000	34	Cloth-bag purging device (for 15V)	YW90036000600
8	Control box	YW09033006000	35	Connection nut	BH12030400410
9	Alarm Lamp *	BL90011500020	36	Hopper cover	-
10	Lower hinge	BL32000600140	37	Reverse-cleaning pipe	BR10281500050
11	Hexagonal nut M5 anti-loose	YW64000500000	38	Reverse cleaning pipe nozzle	BH130330000810
12	Hinge pin	BH10006003110	39		
13	E-rings 6	YW66000600000			
14	Snap hook block *	YR40000600800			
15	Snap hook *	YW02003000400			
16	Locknut M4	YW64040700100			
17	Split washer of filter cloth *	YR40006000000			
18	Cloth-bag *	BP82006000004			
19	Material inlet pipe	BL32000600020			
20	Material inlet pipe fastener *	YR10061200000			
21	Storage hopper	-			
22	E-type washer E5	YW66000500000			
23	Iron rod	BH10061400040			
24	Parerail discharging plate assembly SAL	BH90601200050			
25	Air vent window *	YR40002400100			
26	Square base	BA10040000260			
27	Upper hinge	BL320006000240			

\* means possible broken parts. \*\* means easy broken part. and spare backup is suggested.  
Please confirm the version of manual before placing the purchase order to guarantee that the  
item number of the spare part is in accordance with the real object.

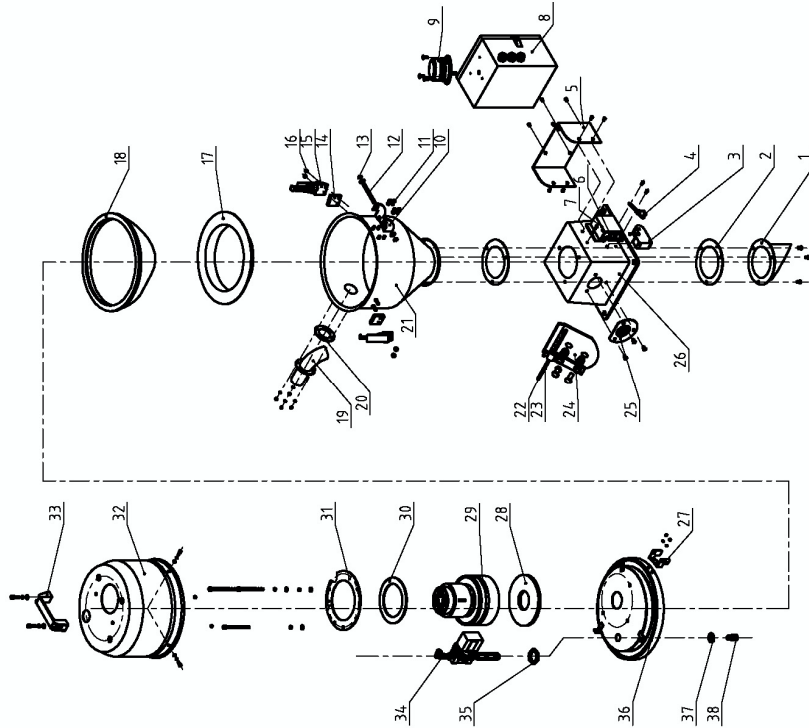



# 4. Electrical Circuit Diagram

## 4.1 Main Circuit Diagram (115V)

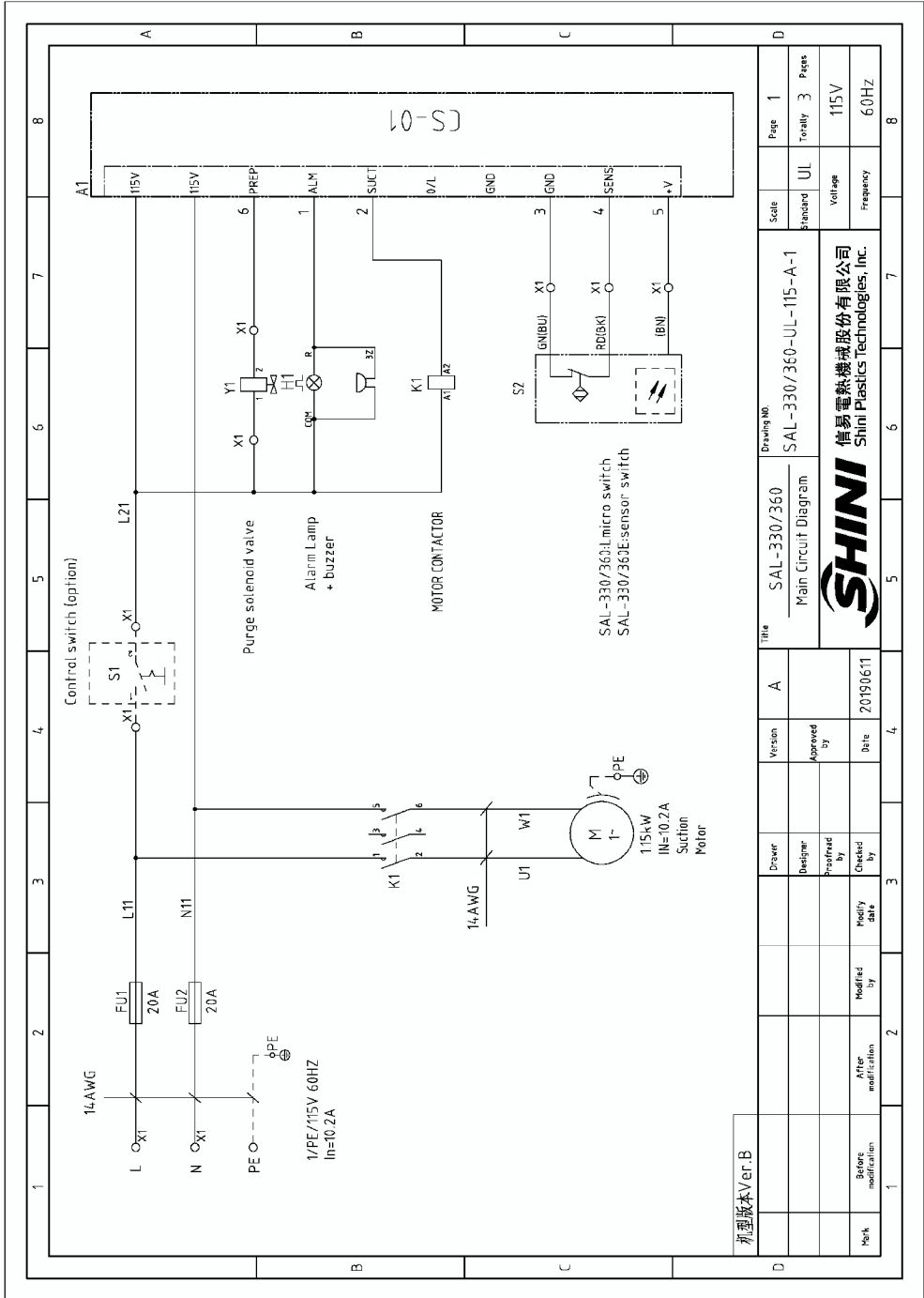

## 4.2 Electrical Components Layout (115V)

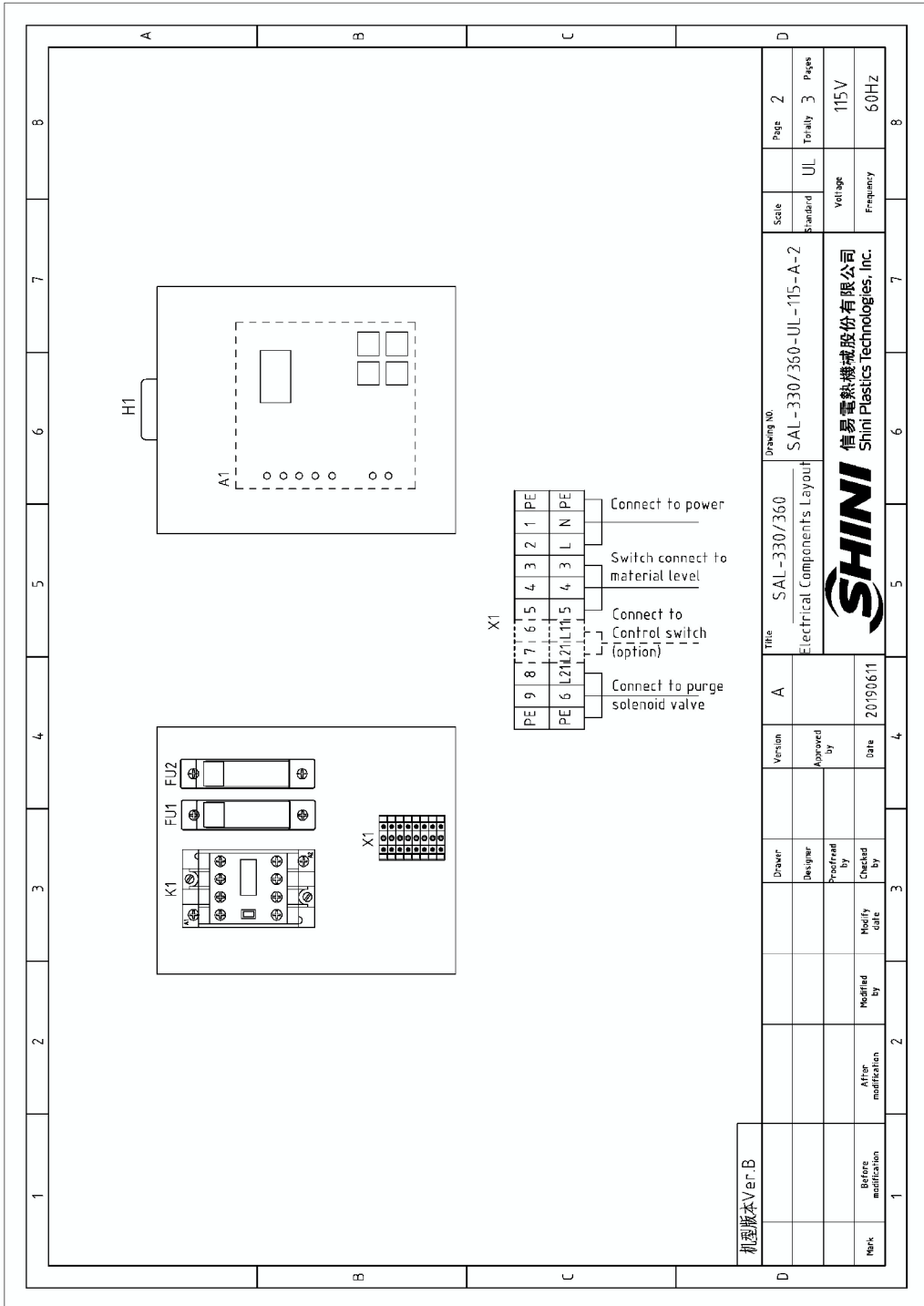



## 4.4 Main Circuit Diagram (230V)

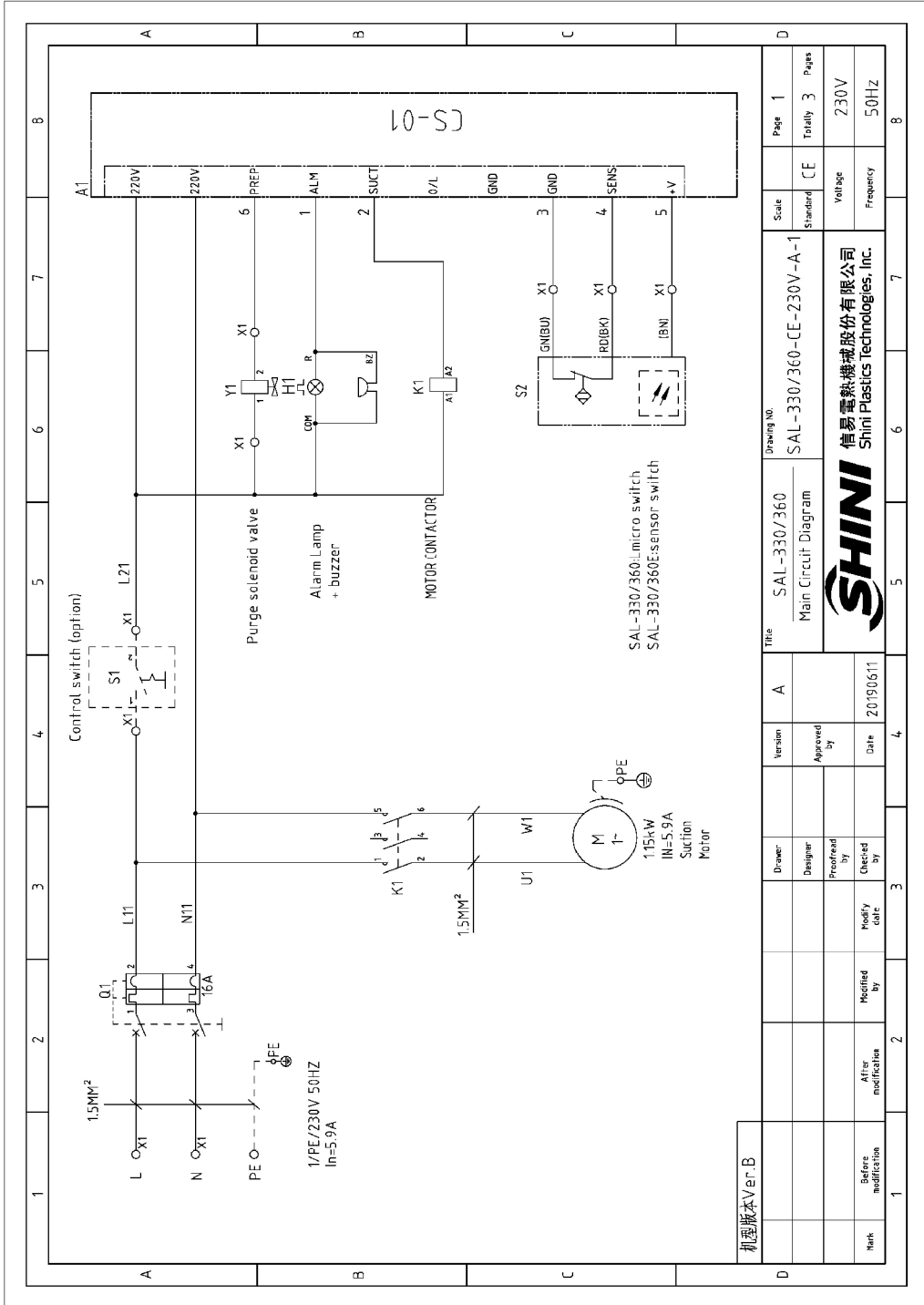

机匣版本 Ver.B		Scale	Standard	CE	Page 1	Totally 3	Pages
Drawn:	Designer:	Checked by:	Modified by:	After modification:	Title: SAL-330/360 Main Circuit Diagram		
Version:	Approved by:	Date:	Drawing No. SAL-330/360-CE-230V-A-1				
Before modification:	Modify date:	20190611	Voltage: 230V				
			Frequency: 50HZ				
			SHINI 信易電熱機械股份有限公司 Shini Plastics Technologies, Inc.				

## 4.5 Electrical Components Layout (230V)

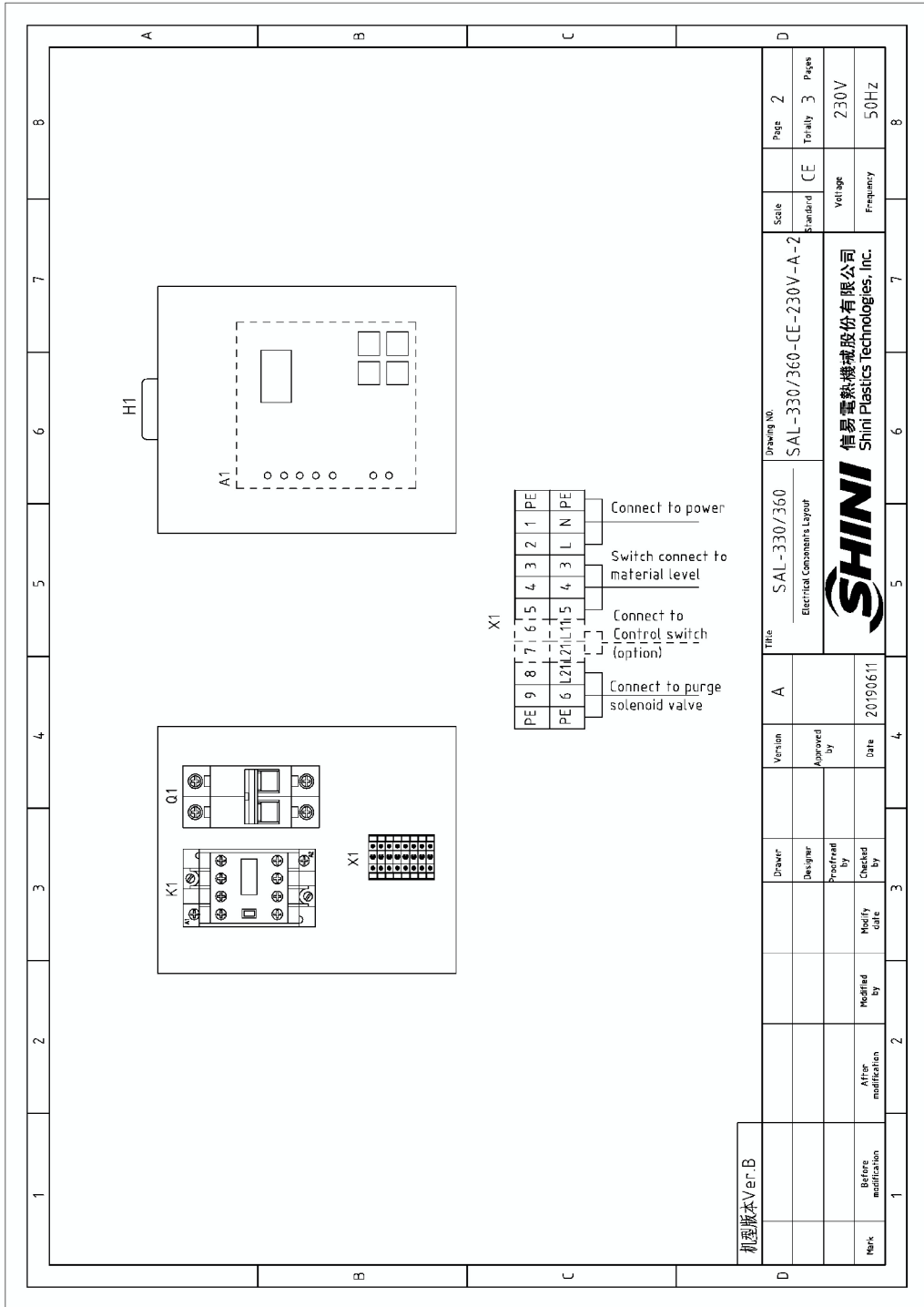

机型版本 Ver. B	Version	Title		Scale	Page
	Designer	SAL-330/360	Standard	2	
	Specified by	Electrical Components Layout		Totally	3
	Checked by	SHINI 信易電熱機械股份有限公司 Shini Plastics Technologies, Inc.		Voltage	230V
Before amendment	Modify date	Date		Frequency	50Hz
		20190611			

## 4.6 Electrical Components List (230V)

1	2		3	4	5	6	7	B	
序号/NO	符号/Symbol	名称/Name	制造商/Manufacturer	型号/Type	规格/Specification	数量/Number	物料编号/Material number	备注/Remark	
1	Q1	断路器/Circuit Breaker	TECO	BM-63C/2016S	16A	1	YE10201600100		
2	K1	交流接触器/AC Contactor	SCHNEIDER	LC1-D09MTC220V	230V 50/60HZ	1	YE00109700100		
3	S1	控制开关/Control Switch	SHINI	303	250VAC 10A	1	YE10030300000	(2)	A
4	S2	微动开关/Micro Switch	JUCHE	LXW5-11G2	250V 10A	1	YE14511200000	(1)	
5	H1	警报灯+蜂鸣器/Alarm Lamp+ buzzer	HONGYUN	----	AC 115/230V	1	BL90011500020		
6	A1	微电脑主板/Microcomputer Mainboard	YUYUN	CS-01	230VAC 50/60HZ	1	YE80122000000		
7	X1	接线端子/Terminal Board	HONEYWELL	SK2.5	2.5mm <sup>2</sup>	9	YE60002503200		
8		接地端子/Terminal Board	HONEYWELL	GK2.5	2.5mm <sup>2</sup>	2	YE60002503400		
9		接线端子/Terminal Board	HONEYWELL	SK2.5	2.5mm <sup>2</sup>	2	YE60002503200	(2)	
10		Terminal fittings E/GK series	HONEYWELL	---	PCS	4	YE60000003900		
B	M	马达/Motor	AMETEK	---	230VAC 1.15KW	1	---	(1)	B
C									
D									
机版本Ver:B Note: (1) Means not part of control box. (2) Optional manual control switch									
Title			Version	A	SAL-330/360	Drawing No.	SAL-330/360-CE-230V-A-3	Scale	Page 3
Electrical Components List			Designer	Approved by	Electrical Components List	SAL-330/360-CE-230V-A-3	Standard	CE	Totally 3
Modified by			Checked by	Date	20190511	Voltage	230V	Frequency	50Hz
Before modification			Ready date	Date	20190511	Frequency	50Hz	Voltage	230V
1	2	3	4	5	6	7	8	9	B

## 4.7 Main Electrical Components Description

### 4.7.1 AC Contactor

It is mainly used to connect and disconnect power supply

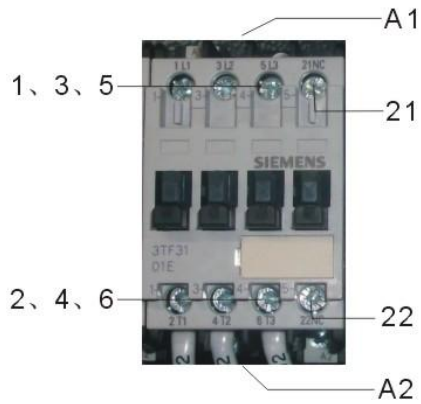

Picture 4-1: Contactor

A1-A2: Contactor coil      21-22: Contact      21-2. 3-4. 5-6: Main contact

## 5. Installation and Debugging

Make a careful study of this chapter before installation.



The machine must be installed according to the steps below. Power supply should be connected by qualified electricians.

### 5.1 Installation of SAL-330 / 360

#### 5.1.1 Installation Methods of SAL-330 / 360

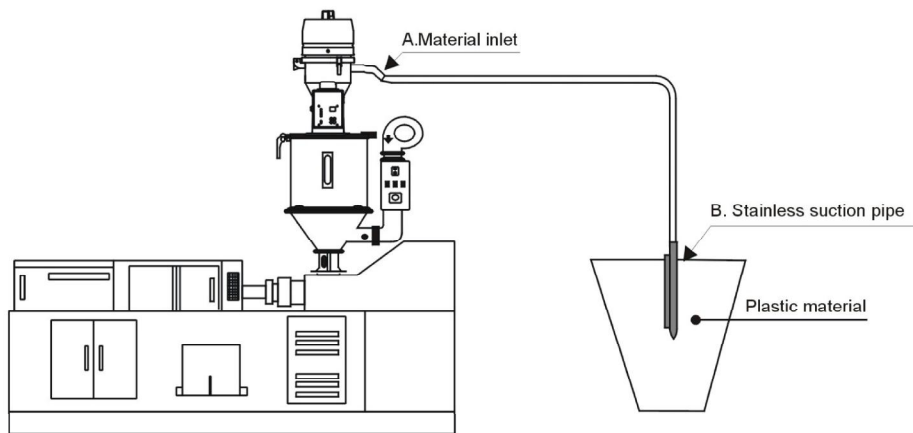

Picture 5-1: Installation methods of SAL-330/360

Notes for Installation and Positioning:

- 1) Machine just can be mounted in vertical position. Make sure there's no pipe, fixed structure or other objects above the installing location and around the machine which may block machine's installation, hit objects or injure human person.
- 2) For easy maintenance, it's suggested to leave 1m space around the machine.
- 3) Machine should be placed on water-level surface. If it needs to be mounted on a higher surface (e.g. the scaffold or the interlayer), should ensure its structure and size could bear the weight and size of the machine.

#### Machine Installation

Install the whole suction machine (SAL-330 / 360) onto the hopper dryer (see the picture above), fix the four fixation holes in the mounting base. Connect one



end of the conveying hose to material inlet (A), and the other end to the stainless suction pipe (B), then insert the pipe into the storage tank.

### Circuit Connection

The machine requires compressed air to finish filter cleaning function, so please connect to the compressed air. The pressure of compressed air: 4~6kgf/cm<sup>2</sup>



Please make sure that the main power is shut off when you connect the machine with power supply!

### 5.1.2 Installation Methods of SAL-330/360 Optional Proportional Valve SPV-U

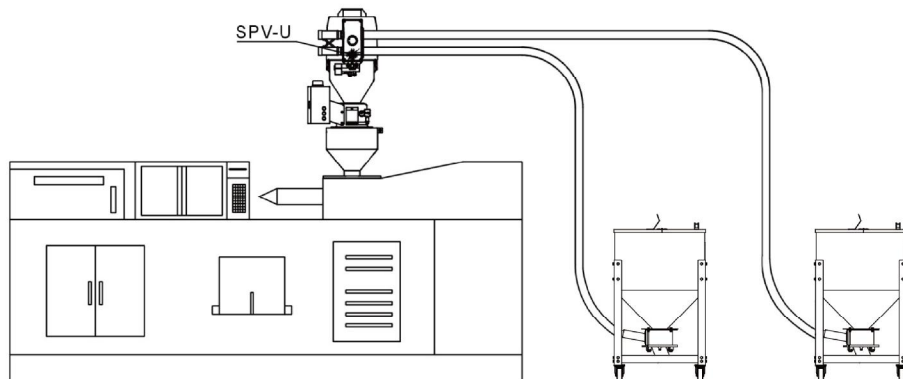

Picture 5-2: Installation method of optional SPV-U

### Machine Installation

Mount SPV-U at material inlet of SAL-330/360, connect two material inlets of SPV-U to two feeding pipes respectively, insert another end of the feeding pipes in the hoppers.

### Circuit Connection

The machine requires compressed air to finish filter cleaning function, so please connect to the compressed air. The pressure of compressed air: 4~6kgf/cm<sup>2</sup>

## 5.2 Installation Space

During installation of the machine, keep at least 1m installation space around the machine as shown by the picture.

Do not install the machine in a position crowded with other objects. This would cause inconvenience to operation, maintenance and repair.

Do not sit on the machine.

Keep away flammable and explosive goods.



Picture 5-3: Installation space

## 6. Application and Operation

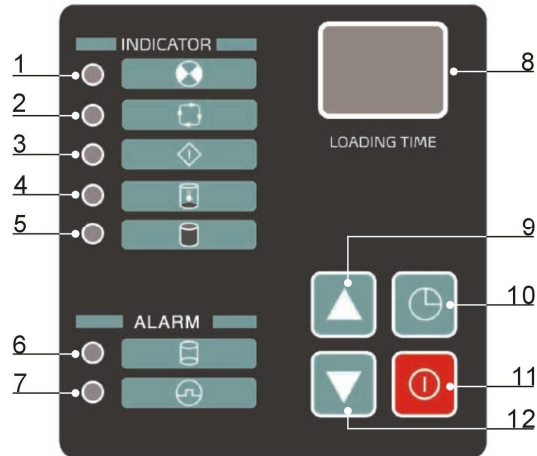



Picture 6-1: Control panel



Table 6-1: Control panel description

No.	Description	Function
1	Power indicator	Machine power on
2	Operation indicator	Machine run or stop
3	Preparation indicator	Suction preparation
4	Suction indicator	Material suction
5	Full load indicator	Hopper full load
6	Shortage indicator	Material shortage
7	Overload indicator	Motor alarm
8	Time/parameter display	Display the time/parameter
9	Increase key	Add the value
10	Set key	Enter parameter setting
11	Start/stop key	Machine start/stop control
12	Decrease key	Decrease the value

## 6.1 Control Panel

1. Press  to set a proper conveying time of material. For commonly used materials, set the conveying time as 20 seconds.
2. Press  to make the machine start loading material. Press  again to stop working of the machine.



The machine will stop working and sound the alarm at the time of material shortage. Press  to switch off the machine. After adding material or fixing the problem, press  to make the machine resume working.



Please clean the filter screen periodically to keep effective suction power.

## 6.2 Function Setup

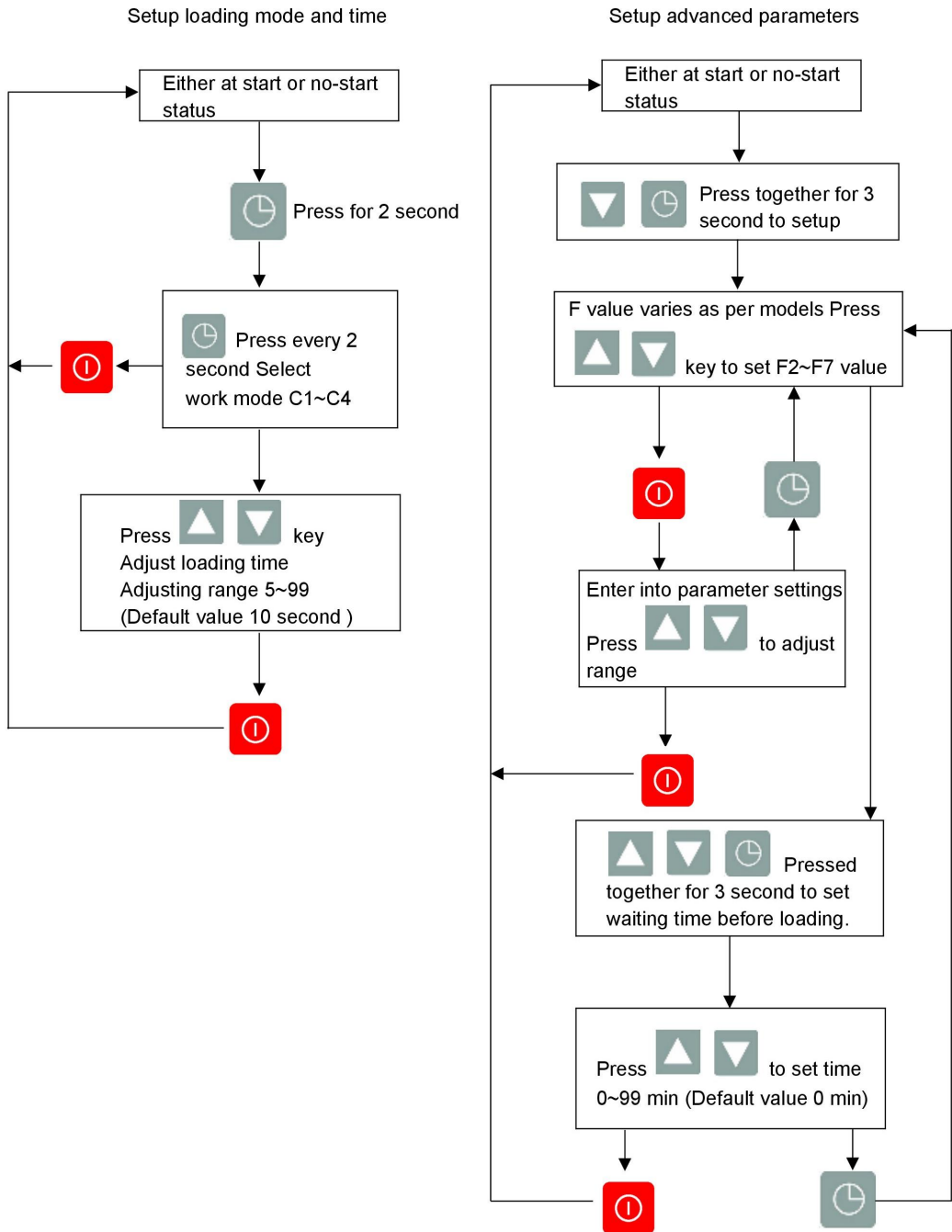
### 6.2.1 Setup



## 6.2.2 Actions

1. Press down  to switch between start / stop status.
2. Press  key to select loading mode.

Mode	Meaning	Suitable model
C1	Auto loading, material shortage alarms whenever no material being loaded.	Applicable to SAL-700G / 800G models
C2	After auto loading, purge as per set period and times.	Applicable to SAL-330 / 360 models
C3	Motor reverse running for dust separating.	Applicable to SAL-430 / 460 models
C4	Auto loading, material shortage alarms after three time no material being loaded.	Applicable to SAL-700G / 800G models

3. At standby state, the seven sectional display will display loading time.
4. Action flow:

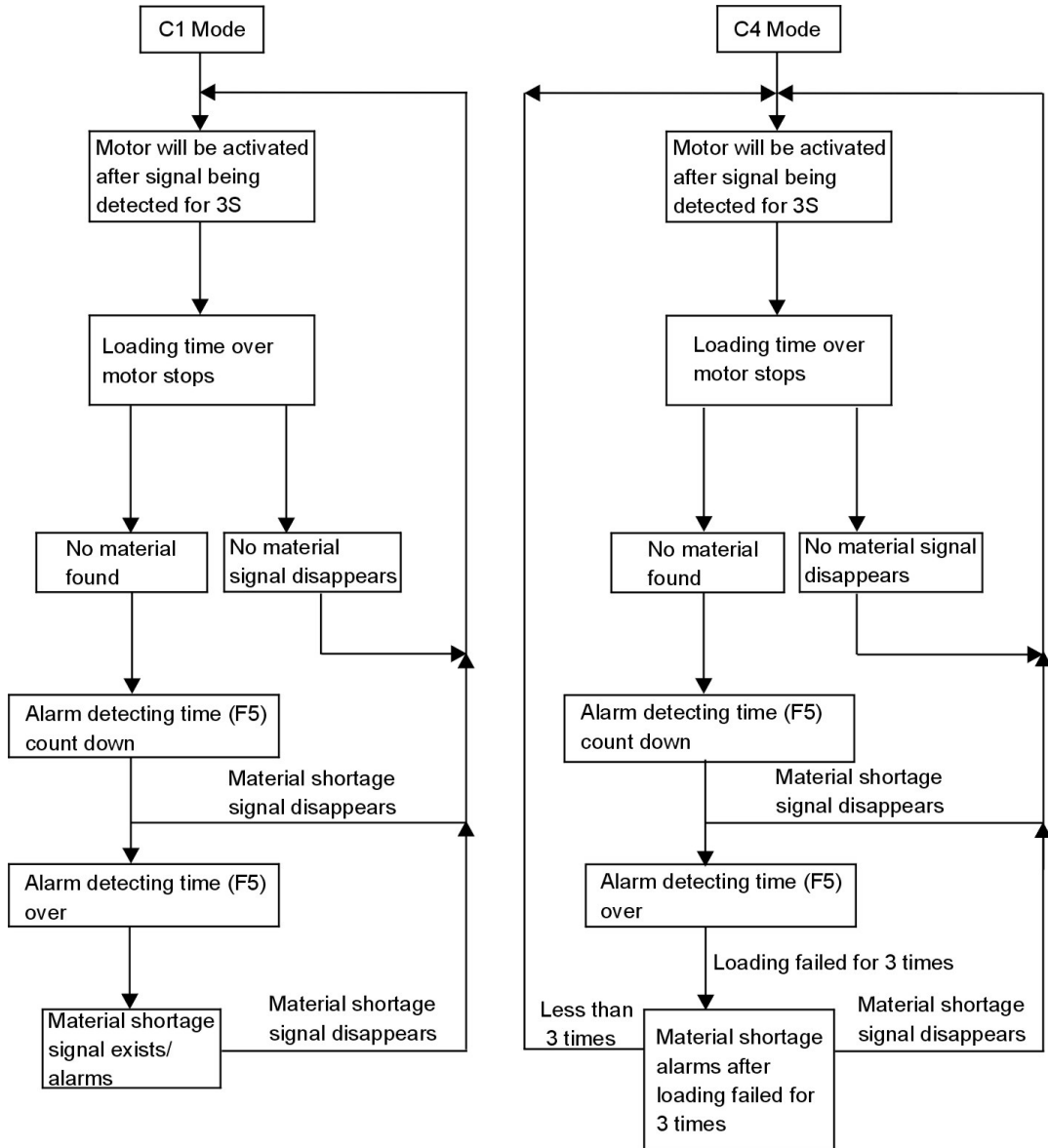

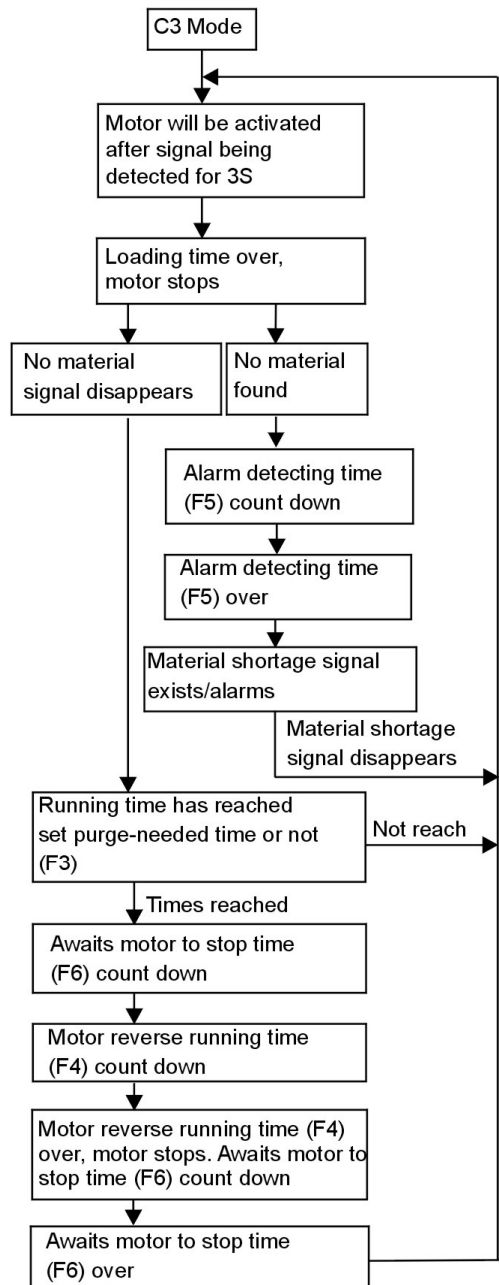
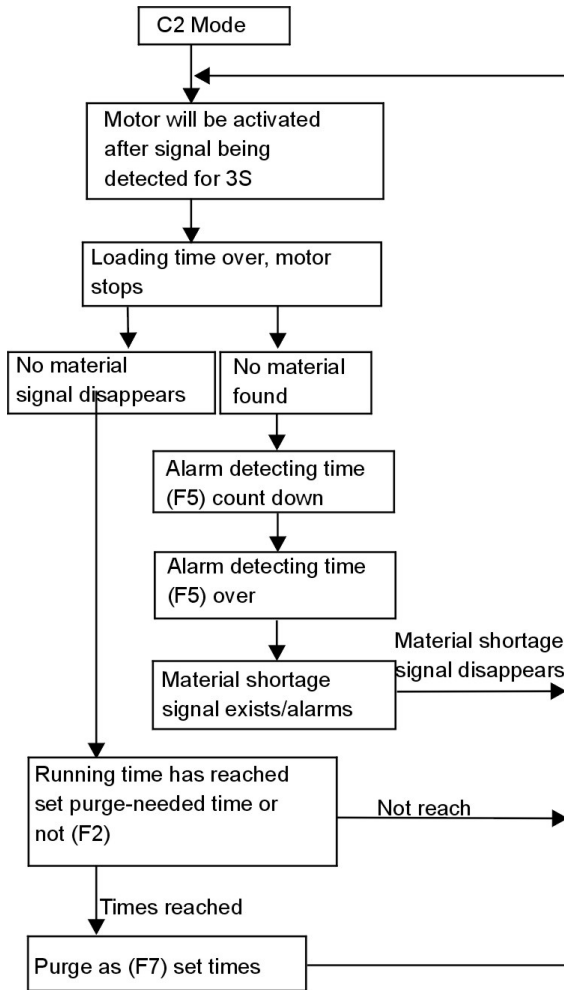



### 6.2.3 Parameter List

Code	Status	Default Value	Adjusting Range	Mode
F2	Necessary spray washing times every several times for operation	3times	1~10 times	C2
F3	Necessary cleaning times for reverse running every several times of operation	3 times	1~10 times	C3
F4	Motor reverse running time	10sec	5~30 sec	C3
F5	Alarm detecting time	20 sec	10~40 sec	C1,C2,C3,C4
F6	Awaits motor to stop time	30 sec	30~99 sec	C3
F7	Purge times	2 times	1~5 times	C2
F8	Loading latency time	0	0~99 times	C1,C2,C3,C4

### 6.2.4 Other Settings

1. Any setting before power on will be saved automatically and back to shut off state after 5 second of no operation.
2. Any setting after power on will be saved automatically and back to standby state after 5 second of no operation.
3. No material shortage signal is being detected even after all action is over, then if press ▲▼ key for 3 second, motor will perform reverse running action, when release the ▲▼ keys to stop motor and await the motor stop count down and back to standby state to detect material shortage signal. (The function only suitable for SAL-430/460 model)
4. Function of the jumper: functions of C1, C3 and C4 will be activated when jumping out which is applicable to SAL-700G / 800G / 430 / 460. When disconnected, only functions of C1, C2 and C4 are available which can be used for SAL-700G / 800G / 330 / 360.



## 7. Troubleshooting

### 7.1 Troubleshooting for SAL-330/360 Series

Failures	Possible Causes	Solutions
Motor does not work long after material discharged	Did not turn on main power or control switch or poor connection of the switches	Turn on main power switch and control switch and make sure they keep good contact.
	Poor connection of microswitch or photoelectrical sensor	Adjust or replace
	Signal wire broken	Refix signal wire
Motor keep on working after the hopper is full filled	Contactors malfunctions	Repair or replace contactor
Can not full-load the material for several times or alarm indicating material shortage	Material is used up	Add material to storage bin
	Leakage in conveying hose	Lock up or replace conveying hose
	Filter screen is blocked	Clear up filter screen
Motor does not work	Short of phase or motor failures	Repair or replace
Fuse melt after startup of the machine	Short circuit or motor failures	Check electrical circuit
The alarm indicating motor overload	Filter screen is blocked	After cleaning of filter screen, press Reset on the overload relay.
	Phase shortage	After fixed the circuit, press Reset on the overload relay.
Poor material liquidity in the pipe	Over or lack of air quantity	Adjust air inlet location of the suction box. Avoid small bending of the elbow.

## 8. Maintenance and Repair

All repair work should be done by professionals to prevent personal injuries and damages of the machine.

### 8.1 Filter Screen

1) For SAL-330/360 series, filter screens are fitted. They need to be cleaned periodically or at the time when conveying capacity of the machine decreases. Loosen the clips or screws at the hopper lid, take down the hopper lid and take the filter screen out. Clear up all the dusts and impurities on the filter screen to make smooth airflow through the screen so that suction power of the machine can be enhanced.

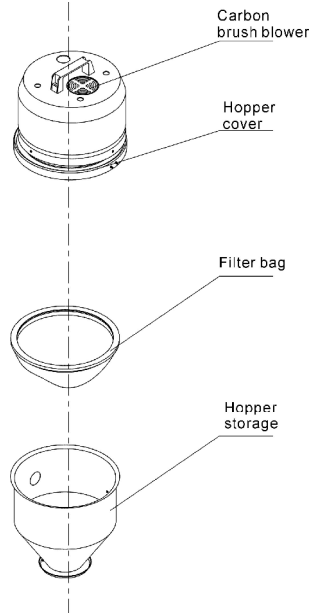

Picture 8-1 : Filter screen

2) Check the status of motor performance. If the motor can not start or makes loud noises, repair or replace the motor.

### 8.1.1 Service Life of Product Key Part

Name of the Parts	Service Life
Motor	Above 5 years
Contactator	Above 100,000 act

## 8.2 Hopper

- 1) Loose the snap hook, and take out hopper cover.
- 2) Use high pressure air to blow away all the material remains.
- 3) Re-fix the hopper cover and fasten the snap hook.



Note!

please make sure that the main switch is shut off before cleaning.

## 8.3 Cloth Filter

1. Loosen the spring fastener on the loader, uplift the loader cover and externally rotate it along the axis, take out the filter bag and clear away the dust on it.
2. Filter bag cleaning period: Daily.

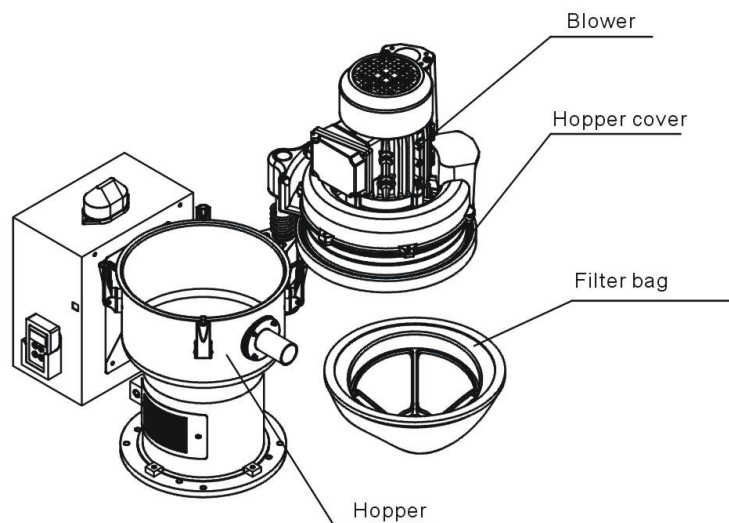

Picture 8-2: Cloth filter

## 8.4 Blower

- 1) Clear the blower from inside out regularly. If there are too much dirt accumulated on the blower, the function of the blower will be affected, such as temperature rising, reduced air volume, higher noise level and vibration. All the above factors are liable to cause mechanical problems.
- 2) The bearing, seal ring and silencer are consumable parts. They should be replaced after a period of time. The fans, covers, and metal screen also need to be replaced when necessary.

## 8.5 Maintenance Schedule

### 8.5.1 About the Machine

Model: \_\_\_\_\_ SN: \_\_\_\_\_ Manufacturing date: \_\_\_\_\_

Voltage: \_\_\_\_\_  $\Phi$  \_\_\_\_\_ V Frequency: \_\_\_\_\_ Hz Total power: \_\_\_\_\_ Kw

### 8.5.2 Check after Installation

- Check that the conveying hose is correctly connected.
- Check that the conveying hose is tightly connected.
- Check that the mounting base is tightly fixed.

#### Electrical Specifications

- Voltage: \_\_\_\_\_ V \_\_\_\_\_ Hz
- Fuse burnt current: One phase \_\_\_\_\_ A Three-phase \_\_\_\_\_ A
- Check phase sequence of power supply

### 8.5.3 Daily Checking

- Check main power switch
- Check filter screen
- Check motor performance

### 8.5.4 Weekly Checking

- Check if there are damaged electrical wires
- Check if there are loose connections of electrical components
- Check if the screws of flange at material inlet are loose or not

### 8.5.5 Monthly Check

- Check the spring lock on the hopper cover is loosed or not.
- Check the non-return valve is deformed or not.
- Check the performance of magnetic proximity switch/photoelectrical sensor.