

# **SPM**

## **Proportional Mixer**

Date: May, 2022

Version: Ver. C (English)





## Contents

<b>1. General Description .....</b>	<b>5</b>
1.1. Coding Principle.....	6
1.2. Features.....	6
1.3. Option .....	6
1.4. Technical Specifications .....	8
1.4.1. Outline Drawings .....	8
1.4.2. Specifications .....	9
1.5. Safety Regulations.....	10
1.5.1. Safety Signs and Labels.....	10
1.6. Exemption Clause.....	11
<b>2. Structure Characteristics and Working Principle .....</b>	<b>12</b>
2.1. Working Principle .....	12
<b>3. Installation and Debugging.....</b>	<b>13</b>
3.1. Mounting on the Injection Molding Machine / Extruder .....	13
3.2. Power Connection.....	13
3.3. Safety Rules of the Touch Panel.....	14
<b>4. Application and Operation.....</b>	<b>15</b>
4.1. Operation Description .....	15
4.2. Screw Replacement.....	19
<b>5. Maintenance and Repair .....</b>	<b>21</b>
5.1. Repair .....	21
5.2. Maintenance .....	21
5.3. Maintenance and Repair Record .....	21
5.3.1. About the Machine.....	21
5.3.2. Check after Installation .....	21
5.3.3. Daily Checking .....	21
5.3.4. Weekly Checking.....	21
<b>6. Trouble-shooting.....</b>	<b>22</b>

## Table index

Table 1-1: Specifications .....	9
---------------------------------	---

## Picture index

Picture 1-1: Proportional Mixer SPM-40-4 .....	5
Picture 1-2: Technical Specifications.....	8
Picture 2-1: Working Principle .....	12
Picture 3-1: Installation of Proportional Mixer .....	13
Picture 4-1: Initial Screen .....	15
Picture 4-2: Menu Screen.....	15
Picture 4-3: Monitoring Screen .....	16
Picture 4-4: Manual Discharge/ Discharge Test Screen .....	16
Picture 4-5: Material Cleaning and Replacement (1).....	17
Picture 4-6: Material Cleaning and Replacement (2).....	17
Picture 4-7: User Identification screen.....	18
Picture 4-8: User Setting .....	18
Picture 4-9: User Parameter Setting.....	18
Picture 4-10: Recipe Screen.....	19
Picture 4-11: Screw Replacement (1).....	19
Picture 4-12: Screw Replacement (2).....	20

# 1. General Description



Please read this manual carefully before using this machine in order to operate correctly against any damage caused due to improper operation.



Picture 1-1: Proportional Mixer SPM-40-4

## 1.1. Coding Principle

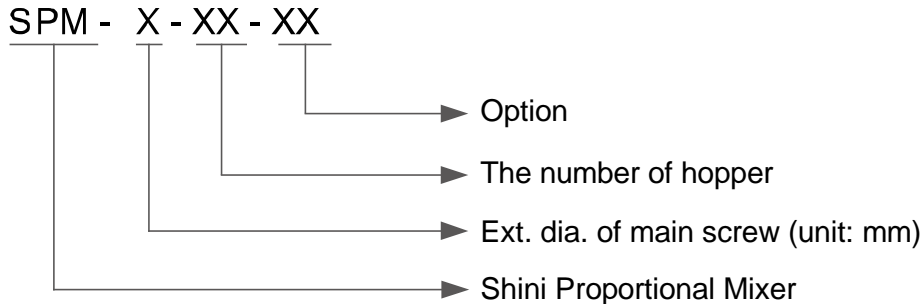

## 1.2. Features

- I Material contacted surface is made of SUS201.
- I Simultaneous metering makes mixing unnecessary that mixes while metering.
- I Materials separated by specific gravity difference can be mixed sufficiently.
- I Particles of different sizes and shapes can be completely mixed.
- I The static will be generated during material mixing, and the product will have color splash. The machine is free of mixing that features better effect.
- I Troubles resulted by dust from mixing have been eliminated completely.
- I Modular assembly structure with convenient assembly and disassembly is easy for cleaning up and exchange.
- I Record current operation mode that unaffected by power failure can return work at once after the power is reconnected.
- I Set manual material cleaning value for convenient material shift.
- I Recipe of recordable is convenient for saving and calling.
- I DC brushless motor is free of maintenance.
- I Material blockage and overload can be detectable with auto shutdown protection and alarm.
- I Equipped with material test port that is easy for customer to test the discharge capacity.

## 1.3. Option

- I The low level sensor is optional of models for convenient alarm in advance when machine is short of material, and add "L" at the end of the model code.

All service work should be carried out by a person with technical training or corresponding professional experience. The manual contains instructions for both handling and servicing.

Any modifications of the machine must be approved by SHINI in order to avoid personal injury and damage to machine. We shall not be liable for any damage caused by unauthorized change of the machine.

Our company provides excellent after-sales service. Should you have any problem during using the machine, please contact the company or the local vendor.

Shini Hotline Service:

Headquarter and Taipei factory:

Tel: + 886 (0)2 2680 9119

Shini Plastics Technologies (Dongguan), Inc.:

Tel: +86 (0)769 8331 3588

Shini Plastics Technologies (Pinghu), Inc.:

Tel: +86 (0)573 8522 5288

Shinden Precision Machinery (Chongqing), Inc.:

+86 (0)23 6431 0898

## 1.4. Technical Specifications

### 1.4.1. Outline Drawings

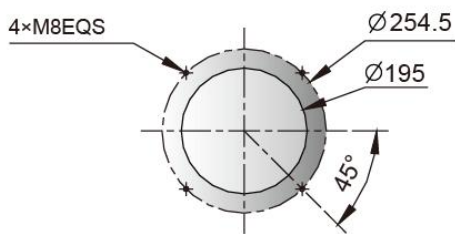
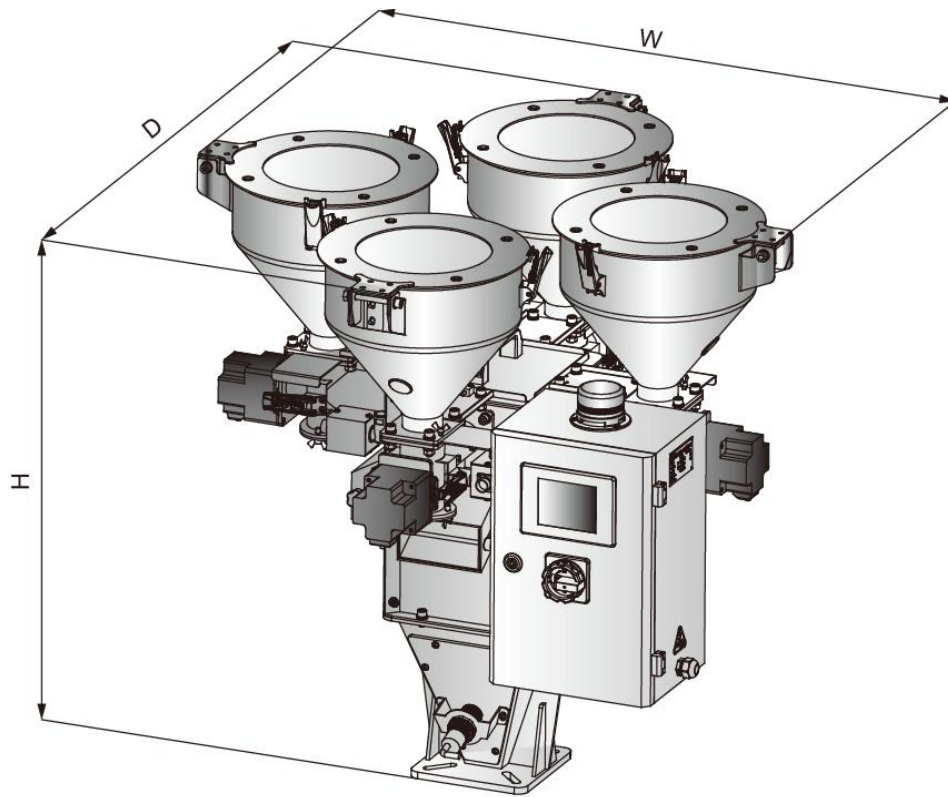

Upper hopper cover  
mount size

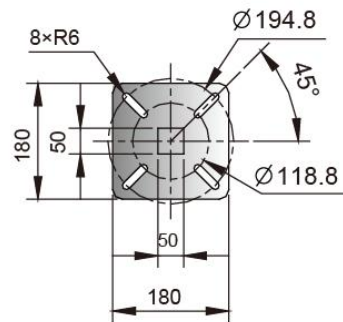

Base mount hole size

Picture 1-2: Technical Specifications



## 1.4.2. Specifications

Table 1-1: Specifications

Model	SPM-40-4		SPM-40-3		SPM-40-2	
Ver.	C		B		B	
Screw ext. diameter ( mm )	40*2	16*2	40*2	16*1	40*1	16*1
Motor power	0.06kw*2	0.06kw*2	0.06kw*2	0.06kw*1	0.0kw*1	0.06kw*1
Gear motor	1:18*2	1:50*2	1:18*2	1:50*1	1:18*1	1:50*1
Max. throughput of single screw (kg/h)	90	2	90	2	90	2
Total max. throughput (kg/h)	184		182		92	
Storage hopper ( L )	6		6		6	
Low level sensor alarm	Option		Option		Option	
H(mm)	880		880		880	
W(mm)	900		900		900	
D(mm)	900		800		500	
Weight(kg)	90		78		66	

Note:

- 1) The output of above model is obtained based on continuous rotating of particles in bulk density of 0.65kg/L, and diameter of 3~5mm.
- 2) Reference for Selection: max. conveying capacity of single screw > actual material dosage of the screw  
> One tenth of the single screw's max. conveying capacity.
- 3) Machine power supply: 1Φ, 220VAC, 50Hz.

## 1.5. Safety Regulations



Warning!

All electrical components should be installed by qualified electricians.

Before connecting the power supply, ascertain whether the power switch specification and rated load protection current are appropriate and safe, and be noted to adjust the main power switch to the "OFF" state before power connection.

During the machine repair and maintenance, turn off the power switch and auto running switch first.

### 1.5.1. Safety Signs and Labels



Danger!

High voltage danger!

This label is stuck on the electrical boxes.

## 1.6. Exemption Clause

The following statements clarify the responsibilities and regulations born by any buyer or user who purchases products and accessories from Shini (including employees and agents).

Shini is exempted from liability for any costs, fees, claims and losses caused by reasons below:

1. Any careless or man-made installations, operation and maintenances upon machines without referring to the Manual prior to machine using.
2. Any incidents beyond human reasonable controls, which include man-made vicious or deliberate damages or abnormal power, and machine faults caused by irresistible natural disasters including fire, flood, storm and earthquake.
3. Any operational actions that are not authorized by Shini upon machine, including adding or replacing accessories, dismantling, delivering or repairing.
4. Employing consumables or oil media that are not appointed by Shini.

## 2. Structure Characteristics and Working Principle

### 2.1. Working Principle

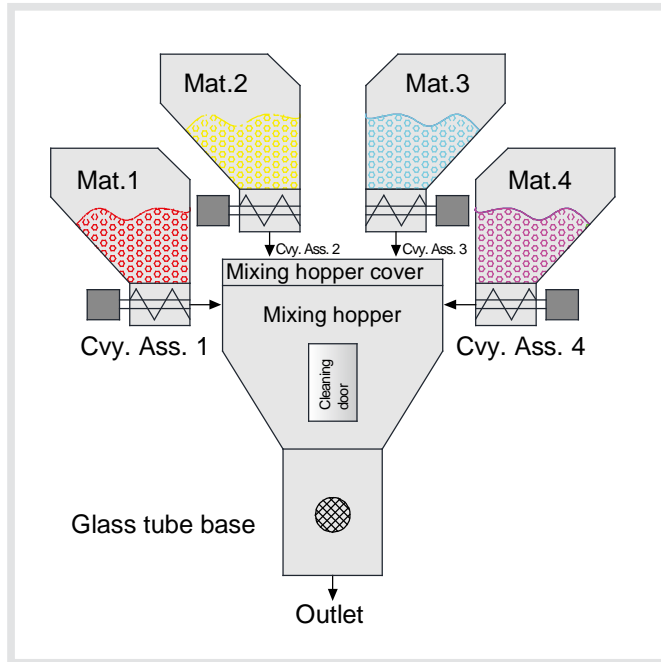

Picture 2-1: Working Principle

Motor starts after receiving the signal from the control box. And materials in hopper will drop into the screw through screw rotating driven by the shaft coupler, which will be conveyed to the base by screw after it receiving the squeeze from the screw as to achieve accurate metering and material conveying purpose.

### 3. Installation and Debugging

Read this chapter carefully before installation. Install the machine by following steps.

This series of models only could be applied in working environment with good ventilation.

#### 3.1. Mounting on the Injection Molding Machine / Extruder

- 1.MST
- 2.SPM
- 3.SHR-U-S
- 4.SG
- 5.SVG

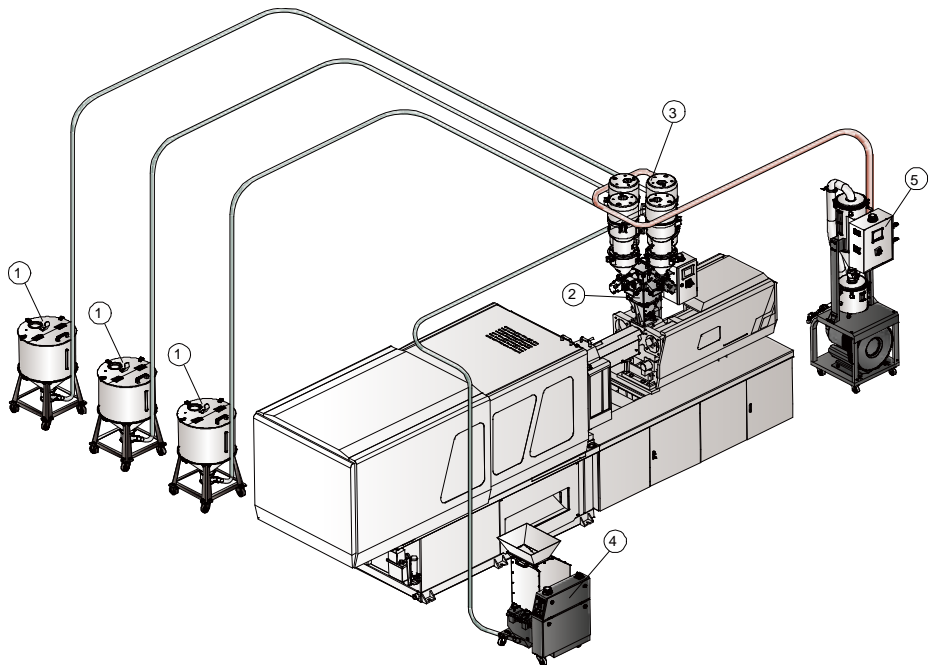

Picture 3-1: Installation of Proportional Mixer

The proportional mixer is directly installed on the injection molding machine / extruder, and then the base is locked with the feed port of the injection molding machine / extruder and fixed with screws.

#### 3.2. Power Connection

- 1) Make sure the voltage and frequency of the power source comply with those indicated on the manufacturer nameplate that attached to the machine.
- 2) Power cable and earth connection should conform to your local regulations.

- 3) Use independent electrical wires and power switch. Diameter of electrical wire should not be less than those used in the control box.
- 4) The power cable connection terminals should be tightened securely.
- 5) The machine requires 3-phase 4-wire power source, connect the power lead (L1, L2, L3) to the live wires, and the earth (PE) to the ground.
- 6) Power supply requirements:  
  
Main power voltage: +/- 5%  
  
Main power frequency: +/- 2%
- 7) ***Please refer to electrical drawing of each model to get the detailed power supply specifications***

### 3.3. Safety Rules of the Touch Panel

- 1) Don't use sharp objects to touch the panel instead of hands, and it must prevent strong collisions of the panel.
- 2) In the dry environment, the touch panel may generate lots of statics. Hence, before touching it, use ground metal to release the static.
- 3) Use economical alcohol or light oil to scrub the touch panel, and other solvents may discolor the touch panel.
- 4) Don't disassemble the touch panel unauthorized and don't remove any printed circuit board of the touch panel, which may cause component damage.

## 4. Application and Operation

### 4.1. Operation Description

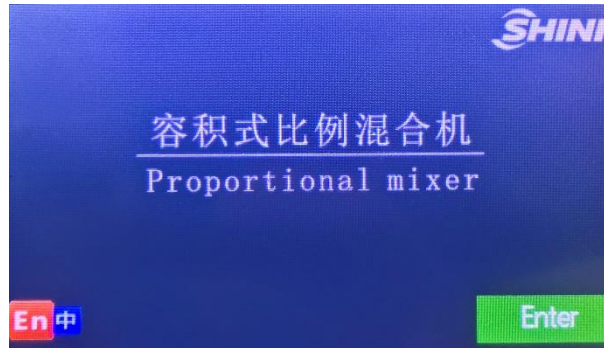

Picture 4-1: Initial Screen

1. Click < Enter System > on the initial screen to enter the menu screen.

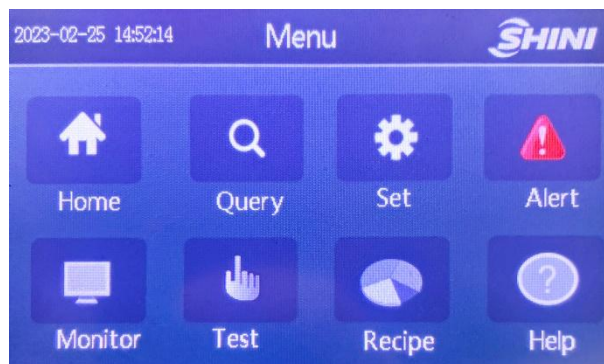

Picture 4-2: Menu Screen

2. Click the < Monitoring > button to enter the monitoring screen, select manual operation mode, and click the < Test > button to enter the test screen;
  - 1) Press buttons 1-4 under the manual test respectively to feed the screws 1-4;
  - 2) Press buttons 1-4 under the discharge test respectively to test the discharge capacity of screws 1-4;



Picture 4-3: Monitoring Screen

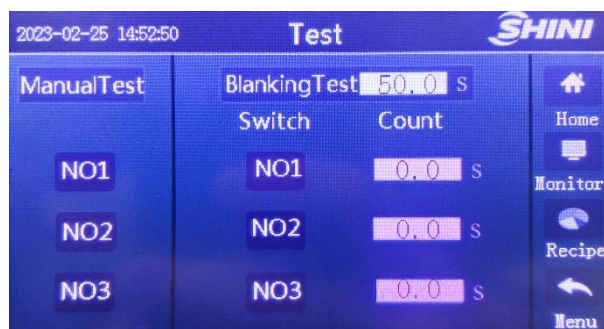

Picture 4-4: Manual Discharge/ Discharge Test Screen

### 3. Materials Replacement of Users

- 1) Click the < Monitoring > button to enter the monitoring screen, click the button above the operation mode, select manual operation mode, and click the < Test > button to enter the test screen;
- 2) Press buttons 1-4 under the manual test respectively to drain the screws 1-4;
- 3) Loosen the butterfly screw, open the material shut-off plate, and then use the air gun to blow the screw's front end to remove the materials;
- 4) If materials can't be cleaned, it can take out the screw and blow it with an air gun;
- 5) Add the material to be replaced.





Butterfly bolt

Picture 4-5: Material Cleaning and Replacement (1)



Open the shut-off  
plate

Discharge  
port

Picture 4-6: Material Cleaning and Replacement (2)

#### 4. Setting

- 1) Click the < Setting > button on the "Menu Screen" to enter the user identification screen, and then click the < User > button to enter the user setting screen, where it can modify the user parameters, time and user password, etc. Click < User Parameter Setting > to enter the user parameter setting screen, where it can choose to set recipe, power-on and auto discharge, language, backlight time, and test time, etc; Enter time setting to set time and date; Enter the user password modification to set the user password. User default password: 123.



Picture 4-7: User Identification screen

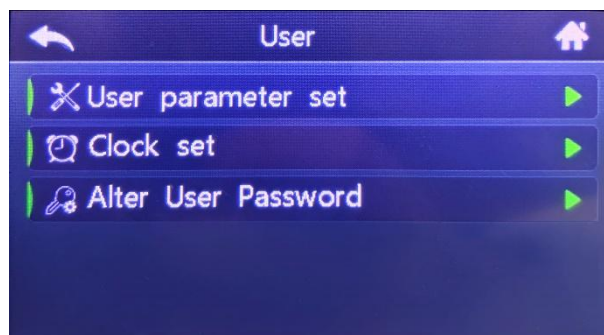

Picture 4-8: User Setting

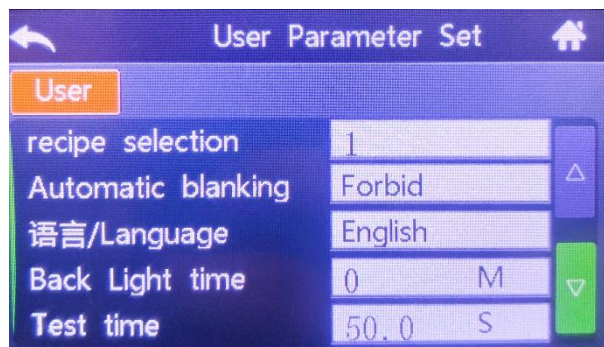

Picture 4-9: User Parameter Setting

- 2) Click < Recipe > button on the menu screen to enter the recipe setting screen.



Picture 4-10: Recipe Screen

- 3) Select the working mode. After setting the recipe, return to the monitoring screen. Press the button above the operation mode, select auto operation mode, and the machine can start working.

## 4.2. Screw Replacement

1. Cut off the power supply, loosen the snap hook on both sides, and pull out the motor to replace the screw quickly.
2. Assemble the screw in reverse order.



Snap hook

Picture 4-11: Screw Replacement (1)

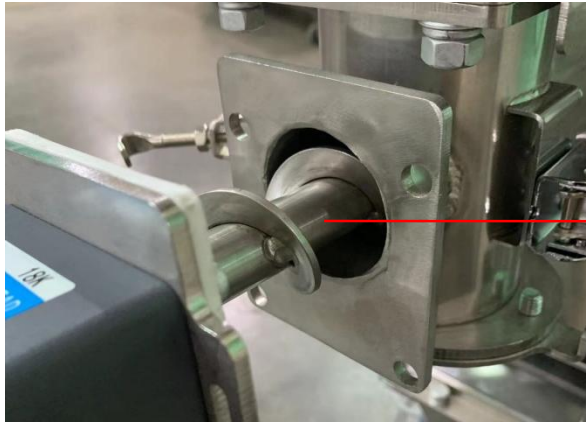

Pull out the  
motor  
and screw

Picture 4-12: Screw Replacement (2)

## 5. Maintenance and Repair

### 5.1. Repair

All maintenance works must be done by professional personnel to avoid personal injury and machine damage.

### 5.2. Maintenance

Please keep the machine clean.

### 5.3. Maintenance and Repair Record

#### 5.3.1. About the Machine

Model \_\_\_\_\_ SN \_\_\_\_\_ Manufacture date \_\_\_\_\_

Voltage \_\_\_\_\_  $\Phi$  \_\_\_\_\_ V Frequency \_\_\_\_\_ Hz Power \_\_\_\_\_ kW

#### 5.3.2. Check after Installation

- Check that all screw installations are correct.
- Check whether the pin is inserted.
- Check whether the mounting base is locked.

#### Electrical Installation

- Voltage: \_\_\_\_\_ V \_\_\_\_\_ Hz
- Fuse melt current: 1 $\Phi$  \_\_\_\_\_ A 3 $\Phi$  \_\_\_\_\_ A
- Check whether the control box power and signal wiring is correct.

#### 5.3.3. Daily Checking

- Check whether the cleaning door and shut-off plate are closed.
- Check whether the base fixing screw is loose.

#### 5.3.4. Weekly Checking

- Check if there are damaged electrical wires.
- Check if the motor's fixed screws are loose.

## 6. Trouble-shooting

Failures	Possible Reasons	Solutions
Control box no display	1. Power disconnected.	1. Connect the power.
	2. Fuse broken or control circuit damage.	2. Replace the fuse or check the control circuit.
Motor doesn't run	1. Parameter input error.	1. Set new parameters
	2. Motor overload	2. Please contact the head office or agent.
	3. Motor damaged.	3. Replace motor.
	4. Motor signal wire broken	4. Replace motor signal wire.
	5. Signal wire miss connected.	5. Check it.
Alarm light on	1. Base cover is opened.	1. Close the base cover.
	2. Hopper low level	2. Feed the hopper.