

VL Series

Venturi Loader

Date: Jan, 2016

Version: Ver.B (English)



Contents

1. General Description	5
1.1 Coding Principle.....	6
1.2 Feature	6
1.3 Technical Specifications	8
1.3.1 Specifications	8
1.4 Safety Regulations.....	9
1.4.1 Transportation and Storage of the Machine	9
1.5 Exemption Clause.....	10
2. Structure Characteristics and Working Principle.....	11
2.1 Main Functions.....	11
2.2 Assembly Drawing	12
2.2.1 Assembly Drawing.....	12
2.3 Electrical Diagram.....	13
2.3.1 Electrical Diagram	13
2.3.2 Electrical Components List.....	14
3. Installation and Debugging	15
3.1 Installation Space.....	15
4. Trouble-shooting.....	16
5. Maintenance and Repair	17
5.1 Filter Clean or Maintenance.....	17
5.2 Maintenance of the Filtering and Pressure Adjusting Valve.....	17

Table Index

Table 1-1: Specifications.....	8
Table 2-1: Electrical Components List	14

Picture Index

Picture 2-1: Working Principle Illustration	11
---	----

Picture 2-2: Assembly Drawing	12
Picture 2-3: Electrical Diagram	13
Picture 3-1: Installation Space	15

1. General Description



Please read this manual carefully before installation and using of the machine to prevent damage or personal injuries.

VL series venturi loader use fast flowing pressurized air to create a vacuum that is used to convey various plastic granules. Air pressure is around 6~8kgf/cm².



机型：VL-50



机型：VL-100



机型：VL-120

1.1 Coding Principle

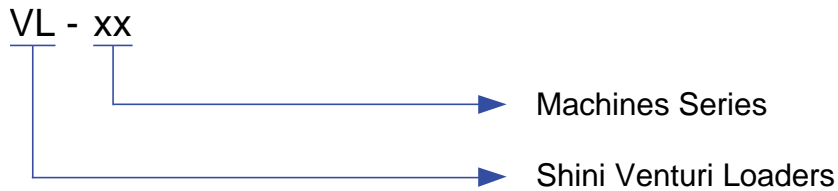

1.2 Feature

- European Type appearance, compact in size and light-weighted.
- Filtered air exhaust does not pollute environment.
- Silent operation, it uses high-pressure air to convey materials.
- Capacitive sensor mounted onto the glass-tube for accurate level sensing.
- Compressed air filter and regulator to eliminate moisture and maintain steady air pressure.
- Quick installation and easy operation with surface polished.
- Easy access to material hopper for convenient cleaning.
- Hopper and base mount positions adjustable.

All service work should be carried out by a person with technical training or corresponding professional experience. The manual contains instructions for both handling and servicing. Chapter 6, which contains service instructions intended for service engineers. Other chapters contain instructions for the daily operator.

Any modifications of the machine must be approved by SHINI in order to avoid personal injury and damage to machine. We shall not be liable for any damage caused by unauthorized change of the machine.

Our company provides excellent after-sales service. Should you have any problem during using the machine, please contact the company or the local vendor.

Headquarter and Taipei factory:

Tel: (886) 2 2680 9119

Shini Plastics Technologies (Dongguan), Inc:

Tel: (86) 769 8111 6600

Shini Plastics Technologies India Pvt.Ltd.:

Tel: (91) 250 3021 166

1.3 Technical Specifications

1.3.1 Specifications

Table 1-1: Specifications

Model	Conveying Capacity (kg / hr)	Material Hopper (L)	Air Flow (L/hr)	Compressed Air (kgf/cm ²)	Max. Conveying Distance (m)	Conveying Hose (inch)	Length of Suction Pipe(mm)	Dimensions (mm) (H×W×D)	Weight (kg)
VL-50	40	0.5	6000	6.0	6	1.25	900	380×145×150	4.5
VL-100	60	2.8	6000	6.0	6	1.25	900	720×165×160	7.0
VL-120	80	3.0	6000	6.0	6	1.25	900	630×240×280	7.5

Note: 1) For hopper inside polished ones, plus "P" at model behind.

- 2) Test condition of conveying capacity: Plastic material of bulk density 0.8kg/L, dia. 3 ~ 5 mm, vertical conveying height: 2 m, horizontal conveying distance: 1 m.

3) Note: Power supply 1Φ, 115 / 230VAC, 50 / 60Hz.

We reserve the right to change specifications without prior notice.

1.4 Safety Regulations

1.4.1 Transportation and Storage of the Machine

Transportation

- 1) VL series are packed cardboard box.
- 2) Do not rotate the machine and avoid collision with other objects during transportation to prevent improper functioning.
- 3) The structure of the machine is well-balanced, although it should also be handled with care when lifting the machine for fear of falling down.
- 4) The machine and its attached parts can be kept at a temperature from -25°C to $+55^{\circ}\text{C}$ for long distance transportation and for a short distance, it can be transported with temperature under $+70^{\circ}\text{C}$.

Storage

- 1) VL series should be stored indoors with temperature kept from 5°C to 40°C and humidity below 80%.
- 2) Disconnect all power supply and turn off main switch and control switch.
- 3) Keep the whole machine, especially the electrical components away from water to avoid potential troubles caused by the water.
- 4) Plastic film should be used to protect the machine from dust and rains.

Working environment

The machine should be operated:

- 1) Indoors in a dry environment with max. temperature $+45^{\circ}\text{C}$ and humidity no more than 80%.

Do not use the machine:

- 1) If it is with a damaged cord.
- 2) On a wet floor or when it is exposed to rain to avoid electrical shock.
- 3) If it has been dropped or damaged until it is checked or fixed by a qualified serviceman.
- 4) This equipment works normally in the environment with altitude within 3000m.
- 5) At least a clearance of 1m surrounding the equipment is required during Operation. Keep this equipment away from flammable sources at least two meters.
- 6) Avoid vibration, magnetic disturbance at the operation area.

Rejected parts disposal

When the equipment has run out its life time and can not be used any more, unplug the power supply and dispose of it properly according to local code.

Fire hazard



In case of fire, CO₂ dry powder fire extinguisher should be applied.



Attention!

No need for regular inspection because all the electrical parts in the control unit are fixed tightly!

1.5 Exemption Clause

The following statements clarify the responsibilities and regulations born by any buyer or user who purchases products and accessories from Shini (including employees and agents).

Shini is exempted from liability for any costs, fees, claims and losses caused by reasons below:

1. Any careless or man-made installations, operation and maintenances upon machines without referring to the Manual prior to machine using.
2. Any incidents beyond human reasonable controls, which include man-made vicious or deliberate damages or abnormal power, and machine faults caused by irresistible natural disasters including fire, flood, storm and earthquake.
3. Any operational actions that are not authorized by Shini upon machine, including adding or replacing accessories, dismantling, delivering or repairing.
4. Employing consumables or oil media that are not appointed by Shini.

2. Structure Characteristics and Working Principle

2.1 Main Functions

Venturi loader use fast flowing pressurized air to create a vacuum that is used to convey various plastic granules. Air pressure is around 6~8 kgf / cm².



Picture 2-1: Working Principle Illustration

2.2 Assembly Drawing

2.2.1 Assembly Drawing

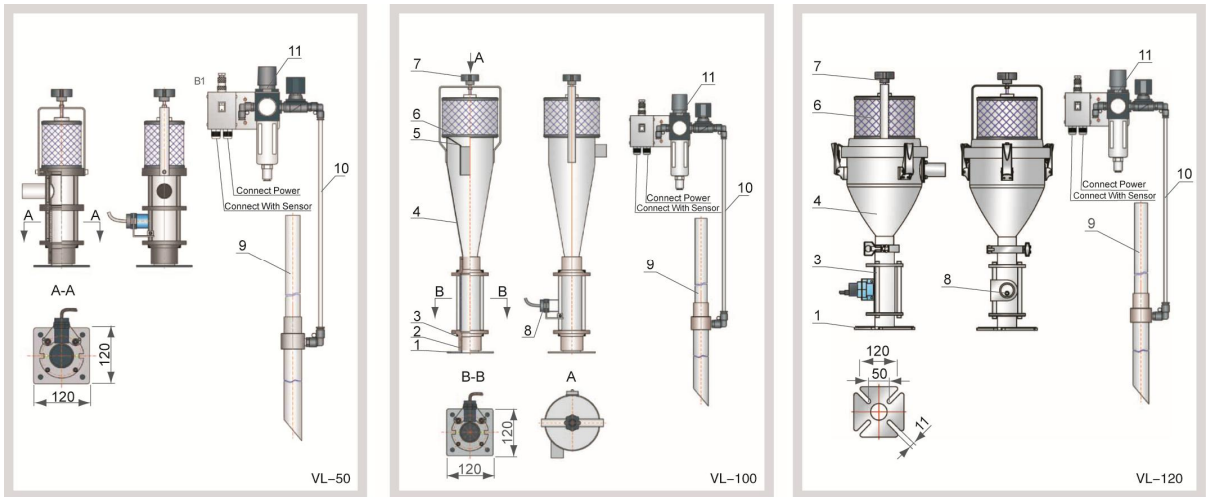

Names of Parts:

- | | | | |
|--------------------|---------------|---------------------------------------|-----------|
| 1. Base | 2. O-ring | 3. Flange connecting pole | 4. Hopper |
| 5. Material baffle | 6. Air filter | 7. Fixing knob | 8. Sensor |
| 9. Conveying pipe | 10. Air pipe | 11. Compressed-air filter & regulator | |

Picture 2-2: Assembly Drawing

2.3 Electrical Diagram

2.3.1 Electrical Diagram

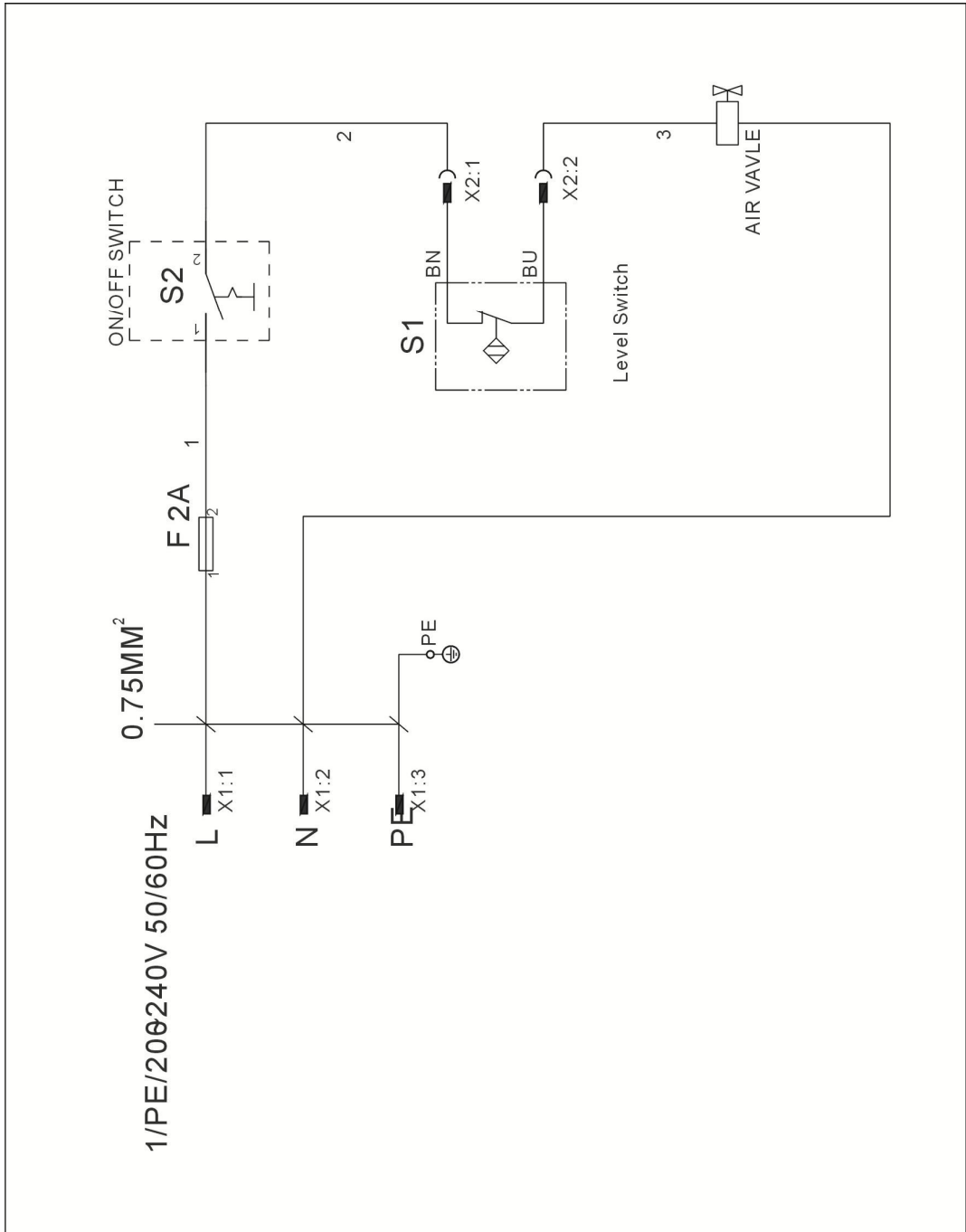

Picture 2-3: Electrical Diagram

2.3.2 Electrical Components List

Table 2-1: Electrical Components List

NO.	Symbol	Name	Specification	Part NO.
1	F	Fuse box	2A	YE46000200000
2	S1	Level switch	20~240VAC/DC	YE15002000000
3	S2	Control switch	19×12mm	YE10121900000
4	Y1	Valve	230VAC 50/60Hz	YE32213100000
5	X1	Power input line	3P 10A	YE51802300000
6	X2	Port	16A 400V 3P	YE68025300100 YE68025300200

* means possible broken parts.

** means easy broken part. and spare backup is suggested.

Please confirm the version of manual before placing the purchase order to guarantee that the item number of the spare part is in accordance with the real object.

3. Installation and Debugging

The feeding hopper can be installed directly on the plastic injector. Connect the venturi pipe device. The venturi pipe connect the suction box of the dryer or the storage bins. Then connect the other point to the hopper, use for steel wire hose and seal the touch-point. Then connect the power supply.

3.1 Installation Space

During installation of the machine, keep at least 150mm installation space around the machine as shown by the picture.

Do not install the machine in a position crowded with other objects. This would cause inconvenience to operation, maintenance and repair.

Do not sit on the machine.

Keep away flammable and explosive goods.



Picture 3-1: Installation Space

4. Trouble-shooting

Failures	Possible Reasons and Solutions
When shortage have been last long, but suction blower don't run	1. The main switch and control switch don't open or the above two don't connect well.
	2. The sensor don't connect well.
	3. The signal wire is break.
	4. The motor winding is burnt out.
After several times of loading the material hopper still empty or the material shortage alarm occur.	1. The storage tank is empty.
	2. The pipe is air leak.
	3. The filter is lock.
	4. The pressure air is too low.
Poor material liquidityin the pipe	Over or lack of air quantity. Adjust air inlet location of the suction box. Avoid small bending of the elbow.

5. Maintenance and Repair

5.1 Filter Clean or Maintenance

The filter is located in the material hopper. Clean the filter periodically or when it's feeding capacity decreases

Clean steps:

Unscrew the star knob, remove the filter. Clean the dust on the filter, make sure to get smooth conveying.

5.2 Maintenance of the Filtering and Pressure Adjusting Valve

In order to avoid air-blocking and to get smooth conveying, please periodically clean the dust on the filter (about once every week).